

Installation Manual

SCANNING SONAR

Model CSH-8L MARK-2

(Product Name: FULL-CIRCLE SCANNING SONAR)

SAFETY INSTRUCTIONS	i
SYSTEM CONFIGURATION	iii
EQUIPMENT LISTS.....	iv
1. MOUNTING.....	1-1
1.1 Hull Unit	1-2
1.2 Transceiver Unit.....	1-12
1.3 Processor Unit	1-13
1.4 Control Unit.....	1-13
1.5 Ground	1-16
1.6 Transducer Cable Extension Kit CSH-1700 (Optional Junction Box).....	1-17
1.7 Motion Sensor MS-100 (option).....	1-17
1.8 DC-AC Inverter (option)	1-18
2. WIRING.....	2-1
2.1 Cabling Outline	2-1
2.2 Hull Unit	2-3
2.3 Transceiver Unit.....	2-6
2.4 Processor Unit	2-9
2.5 Synchronizing Transmission with Other Equipment	2-14
2.6 Transducer Cable Extension Kit (option)	2-17
2.7 DC-AC Inverter (option)	2-18
3. ADJUSTMENT.....	3-1
3.1 Measuring TX Output.....	3-1
3.2 Heading Alignment.....	3-3
3.3 Setting for External Equipment	3-4
3.4 Smoothing the GPS Data.....	3-6
3.5 NMEA Version Setting	3-7
3.6 Adjusting Echo Sounder Video	3-7
3.7 Sea Trial.....	3-8
APPX. 1 JIS CABLE GUIDE	AP-1
APPX. 2 PROCEDURE FOR RETROFITTING	AP-2
APPX. 3 DIP SWITCH SELECTION FOR THAI VERSION SOFTWARE (CSH-8L MARK-2-85 ONLY).....	AP-7
PACKING LIST(S).....	A-1
OUTLINE DRAWING(S)	D-1
INTERCONNECTION DIAGRAM(S)	S-1

**FURUNO ELECTRIC CO., LTD.**www.furuno.com

All brand and product names are trademarks, registered trademarks or service marks of their respective holders.

ECF

(Elemental Chlorine Free)

The paper used in this manual
is elemental chlorine free.

FURUNO ELECTRIC CO., LTD.

9-52 Ashihara-cho,
Nishinomiya, 662-8580, JAPAN

• FURUNO Authorized Distributor/Dealer

All rights reserved. Printed in Japan

Pub. No. IME-13510-A9

(REFU) CSH-8L MARK-2

A : JUN. 2015

A9 : DEC. 02, 2021





0 0 0 1 9 0 9 1 0 1 0











SAFETY INSTRUCTIONS

The operator must read the safety instructions before attempting to operate the equipment.

 WARNING	Indicates a potentially hazardous situation which, if not avoided, could result in death or serious injury.
 CAUTION	Indicates a potentially hazardous situation which, if not avoided, could result in minor or moderate injury.

 Warning, Caution	 Prohibitive Action	 Mandatory Action
----------------------------------------------------------------------------------------------------	------------------------------------------------------------------------------------------------------	------------------------------------------------------------------------------------------------------

 WARNING	
 <p>ELECTRICAL SHOCK HAZARD Do not open the equipment unless totally familiar with electrical circuits and service manual.</p> <p>Only qualified personnel are allowed to work inside the equipment.</p>	 <p>Turn off the power at the switchboard before beginning the installation.</p> <p>Fire or electrical shock can result if the power is left on.</p>
 <p>Do not install the equipment other than the transducer where they may get wet from rain or water splash.</p> <p>Water in the equipment can result in fire, electrical shock or equipment damage.</p>	 <p>Be sure no water leaks in at the transducer installation site.</p> <p>Water leakage can sink the vessel. Also confirm that the transducer will not loosen by ship's vibration. The installer of the equipment is solely responsible for the proper installation of the equipment. FURUNO will assume no responsibility for any damage associated with improper installation.</p>

 WARNING	
 <p>Install the specified transducer tank in accordance with the installation instructions. If a different tank is to be installed the shipyard is solely responsible for its installation, and it should be installed so the hull will not be damaged if the tank strikes an object.</p> <p>The tank or hull may be damaged if the tank strikes an object.</p>	 <p>When assembling the hull unit, fasten the shaft retainer and fastening band with the torques shown below.</p> <p>Shaft retainer: 20 to 25 N•m Fastening band: 6 to 8 N•m</p> <p>If torques are less than the above, water leakage may occur because the shaft may loosen and fall.</p>



CAUTION



Turn off the POWER switch on the hull unit before manually raising or lowering the transducer (with the ratchet wrench).

Bodily injury can result if the ratchet wrench rotates unexpectedly, because the raise/lower motor may start up.



Observe the following compass safe distances to prevent interference to a magnetic compass:

	Standard compass	Steering compass
Processor unit	0.4 m	0.3 m
Control unit	0.3 m	0.3 m
DC-AC inverter	1.4 m	0.9 m



Observing the following speed limits when testing the equipment at sea trial:

Raising/lowering transducer: 16 kn max. Transducer completely lowered: 18 kn max.

Exceeding above limits will damage the equipment and void the warranty.



CAUTION



The zinc block (or propeller zinc assembly) near the transducer must be replaced yearly.

The junction between the transducer and main shaft may corrode, which can result in loss of the transducer or water leakage inside the ship.

Replace the zinc block (or propeller zinc assembly) yearly.



Attach protective earth securely to the ship's body.

The protective earth is required to the transceiver unit and DC-AC inverter (option) to prevent electrical shock.

SYSTEM CONFIGURATION

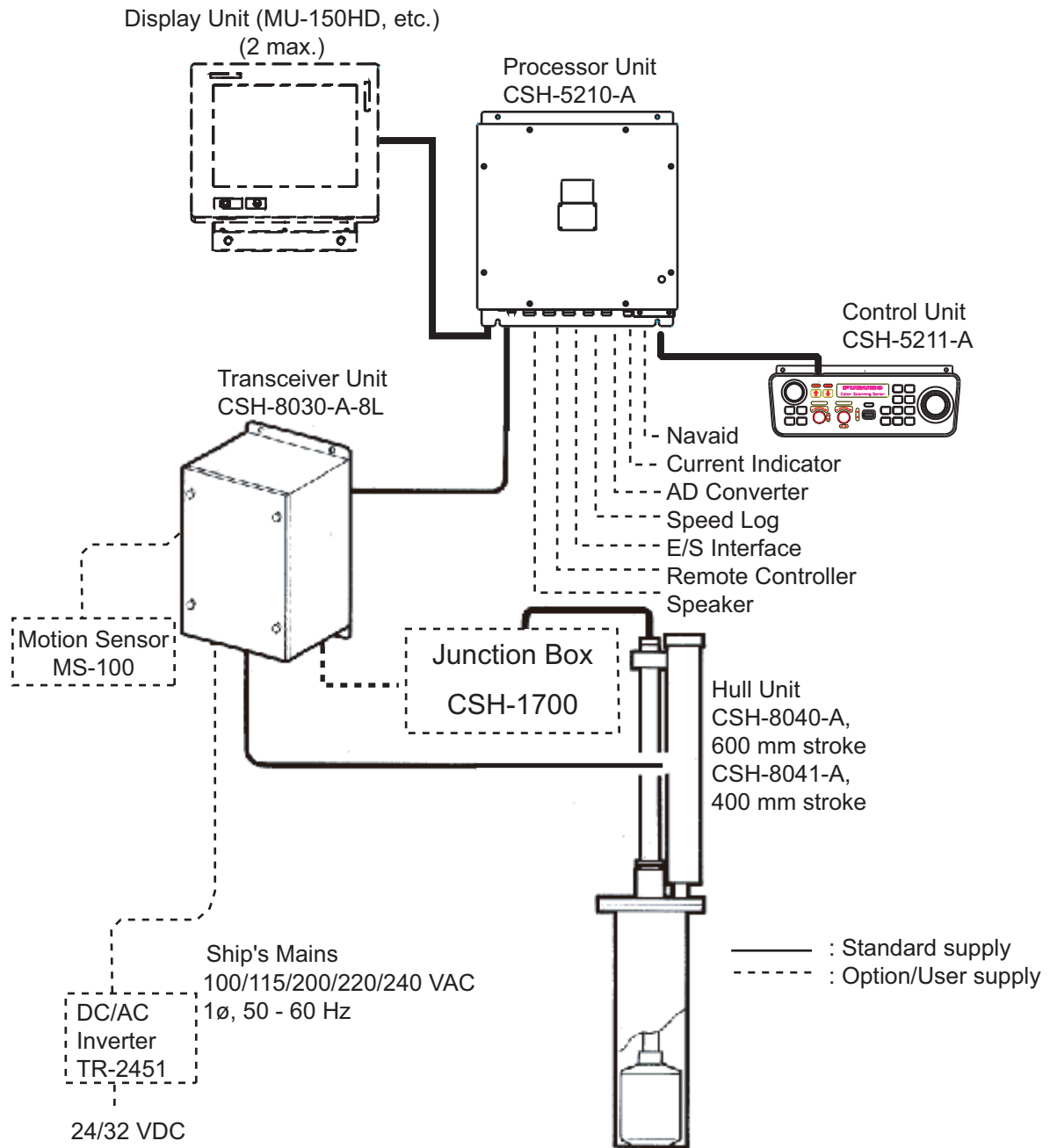

EQUIPMENT LISTS

Standard Supply

Name	Type	Code No.	Qty	Remarks
Processor Unit	CSH-5210-A	–	1 set	
Control Unit	CSH-5211-A	–	1 set	
Transceiver Unit	CSH-8030-A-5L	–	1 set	
Hull Unit	CSH-8040-A	–	1 set	600 stroke
	CSH-8041-A	–		400 stroke
Installation Materials	CP10-05201	006-910-940	1 set	For processor unit
	CP10-05501	006-911-000	1 set	For transceiver unit
	Combinations of the cable are shown below.			
Accessories	FP10-02701	006-905-030	1 set	For control unit
Spare Parts	SP10-02901	006-907-700	1 set	For processor unit
	SP10-03001	006-910-950	1 set	For transceiver unit

Installation materials (Cable combination)

Type	Code No.	Transceiver/ Hull units	Processor/ Transceiver units	Monitor/ Processor units
CP10-05500	000-069-281	S10-15-5	S10-6-15	3COX-2P-6C 5 m
CP10-05510	000-069-282		S10-6-30	
CP10-05520	000-069-283		S10-6-50	
CP10-05530	000-069-284	S10-15-10	S10-6-15	
CP10-05540	000-069-285		S10-6-30	
CP10-05550	000-069-286		S10-6-50	
CP10-05600	000-069-287	S10-15-5	S10-6-15	3COX-2P-6C 10 m
CP10-05610	000-069-288		S10-6-30	
CP10-05620	000-069-289		S10-6-50	
CP10-05630	000-069-290	S10-15-10	S10-6-15	
CP10-05640	000-069-291		S10-6-30	
CP10-05650	000-069-339		S10-6-50	

Name	Type	Code No.	Qty	Remarks
HULL cable	S10-15-5	006-800-510	1	5 m
	S10-15-10	006-800-520		10 m
Processor cable	S10-6-15	006-976-580	1	15 m
	S10-6-30	006-976-590		30 m
	S10-6-50	006-976-600		50 m
Display cable	3COX-2P-6C 5 m	000-146-500	1	5 m
	COX-2P-6C 10 m	000-146-501		10 m

How to select transducer unit combinationsCSH - 8030 - A - 8L - -

(1): Input voltage: 60 (100 VAC), 72 (220 VAC)

(2): Frequency: 107 kHz, 85 kHz

How to select hull unit combinationCSH- - A - - -

(1): Stroke: 8040 (600 mm) or 8041 (400 mm)

(2): Frequency: 107 kHz or 85 kHz

(3): Tank: N (None), S (Steel), F (FRP)

(4): Shaft length: 13 (1300 mm), 15 (1550 mm), 23 (2350 mm), 40 (4065 mm), 94 (945 mm)

Optional Supply

Name	Type	Code No	Qty	Remarks
DC-AC Inverter	TR-2451	–	1 set	
E/S Interface	VI-1100A	–	1 set	
Retraction Tank	OP10-5	–	1 set	Made of aluminum
Speaker	SEM-21Q	–	1 set	
Transducer Cable Extension Kit	CSH-1700	000-068-207	1 set	Junction box, cable assy
Motion Sensor	MS-100	–	1 set	
Remote Controller	CSH-7040	–	1 set	
Fairing	06-021-4502	001-159-790-10	1 set	For an FRP ship

This page is intentionally left blank.

1. MOUNTING

NOTICE

Be sure the power supply matches equipment voltage rating.

Improper power supply will damage the equipment.

Locate the transducer where the affects of noise and air bubbles are minimal.

Noise and air bubbles will affect performance.

When selecting a mounting location keep the following points in mind:

- Keep equipment out of direct sunlight.
- Keep equipment away from air conditioner.
- The useable temperature range of the display unit is 0°C - 50°C.
- Provide sufficient ventilation.
- Select location where vibration is minimal.
- Locate the equipment away from magnets or equipment generating magnetic fields.

Keep the transducer cable away from oil.

Oil can corrode the transducer cable.

Do not expose the transducer to hot water.

Hot water can damage the transducer.

Do not turn on the equipment with the transducer exposed to air.

Exposing the transducer to air may damage it.

1.1 Hull Unit

1.1.1 Mounting location

Discussion and agreement are required with the dockyard and ship owner in deciding the location for the hull unit. When deciding the location, take into account the following points:

- Select an area where propeller noise, cruising noise, bubbles and interference from turbulence are minimal. Generally, the point at 1/3 to 1/2 of the ship's length from the bow or near the keel is the best. On-the-keel installation is advantageous for minimizing oil consumption in comparison with off-the-keel. If the hull unit cannot be installed on the keel, the center of the retraction tank should be within 1 meter of the keel to prevent a rolling effect.

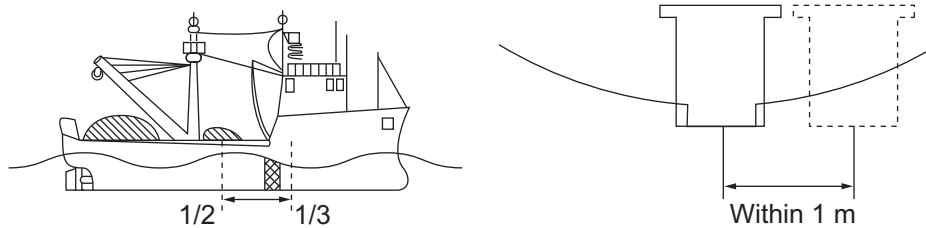

Installation location for hull unit

- Select a place where interference from the transducers of other sounding equipment is minimal. The hull unit should be at least 2.5 meters away from the transducers of other sounding equipment.
- An obstacle in the fore direction not only causes a shadow zone but also aerated water, resulting in poor sonar performance. Be sure to locate the transducer well away from any obstacle in the fore direction.
- The space shown in the illustration below is required around the hull unit for wiring and maintenance. If the transducer is to be operated in ambient temperature below 0°C, the sonar compartment must be provided with a heater to keep the temperature above 0°C.

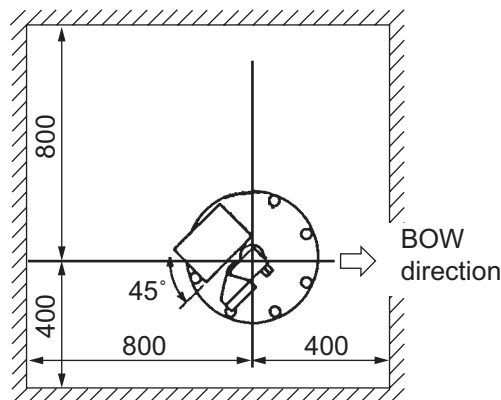

Hull unit maintenance space

When the retraction tank is made locally, finish it so that the welding bead does not protrude on the inner surface of the tank. The tank guide will hit the bead, causing motor burn-out. The gap between the tank and tank guide is 1 mm. Also when installing the tank, orient the welding bead so it faces the port or starboard direction.

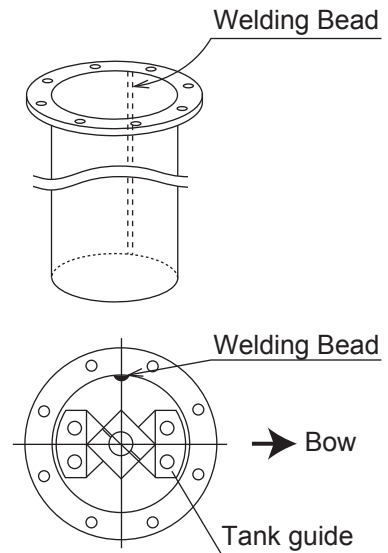

1.1.2 Installation of the retraction tank

The retraction tank is 1000 mm in length as supplied. Shorten the tank referring to the table below so the transducer fully protrudes beyond the keel when it is lowered. Refer to the installation procedure at the back of this manual for details.

		Tank Installation Method		
Tank Cutting		In case of 1000 mm tank 750 mm (600 stroke, shaft length: 1300 mm) 550 mm (400 stroke, shaft length 945 mm)		Cut along the hull bottom.

Note: It is not necessary to cut the main shaft when there is enough space above the hull unit.

How to shorten the retraction tank

1. MOUNTING

1.1.3 Assembly and installation of the hull unit

The hull unit is shipped disassembled as the parts shown on page 1-11 through 1-13. Assemble the hull unit as follows:

Necessary tools

Tool	Rating	Remarks
Wrench	M10 (Diagonal 17 mm)	
Wrench	M10 (Diagonal 30 mm)	
Pipe Wrench	φ55 mm	For tightening gland
Hex Wrench	M6 (Diagonal 3 mm)	For tightening transducer flange

1. Temporarily install the waterproofing attachment on the top of the main shaft and drill holes for socket-set screws.

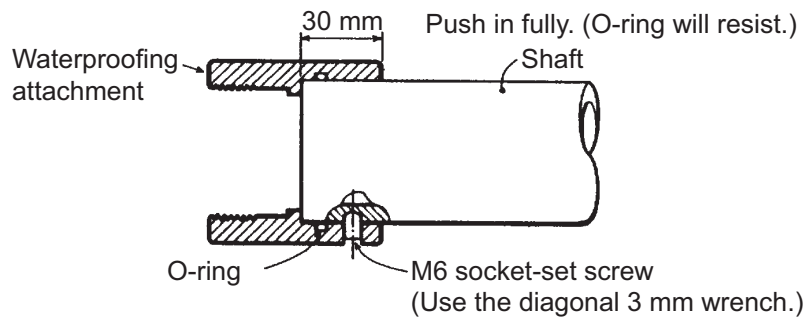

Installation of waterproofing attachment

- a) Mark drilling point on the shaft surface by tightening M6 socket-set screws (2 pcs.).
- b) Remove the waterproofing attachment.
- c) Drill holes less than 2 mm in depth. The drill bit should be stainless steel, φ5, 120° tip. Do not drill holes through the shaft. Use a low rpm drill, and use cutting oil.

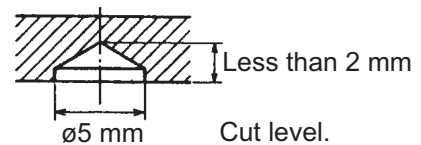

2. Fasten the raise/lower drive assembly to the main body flange with the trunnion shaft.

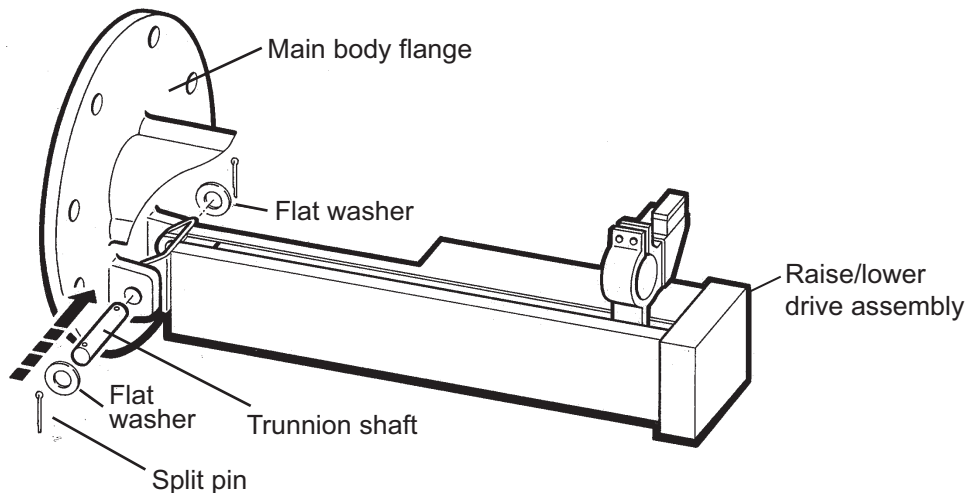

Passing main shaft through the raise/lower drive assy.

- Coat the top of the main shaft with a small amount of grease. Pass the main shaft through the main body flange, and fix it temporarily with the shaft retainer. (The shaft retainer should be secure enough to prevent shaft rotation.)

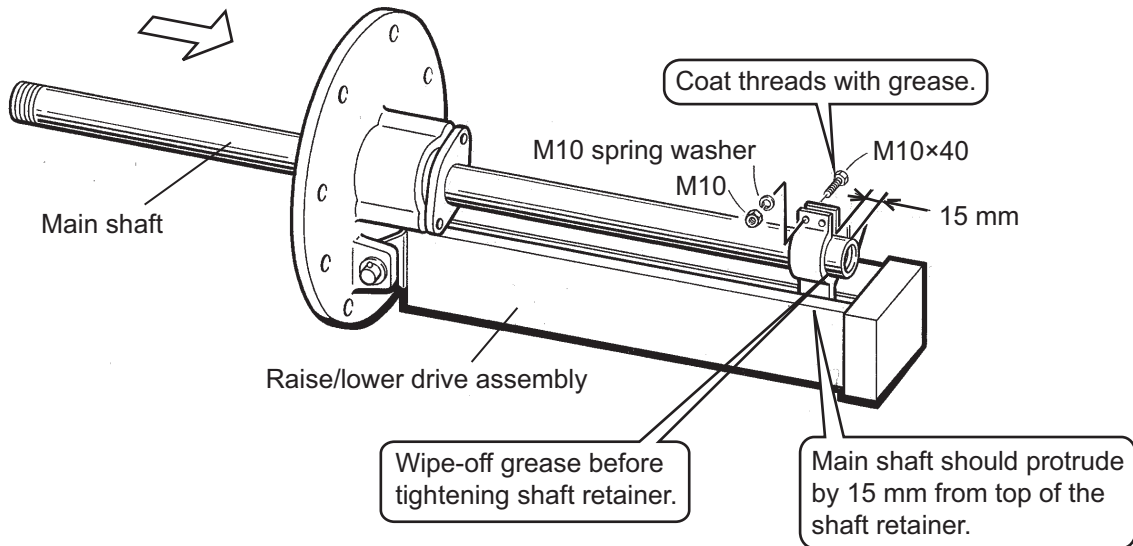

Passing main shaft through the raise/lower drive assy.

- Tape the end of the transducer cable with vinyl tape to pass the cable through the main shaft. Remove sheath of transducer cable by the length shown below with roller knife.

Note 1: Care should be taken not to damage inner wires when cutting the cable sheath, only paper tape exists between the cable sheath and inner wires.

Note 2: Wrap the vinyl tape around the sheath end to bundle the cables.

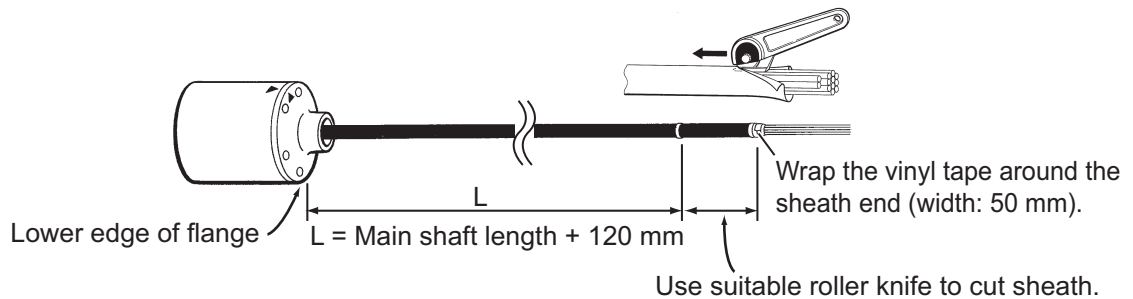

Transducer cable

1. MOUNTING

- After screwing the transducer into the main shaft, fasten two socket-screws (M10×10, supplied).

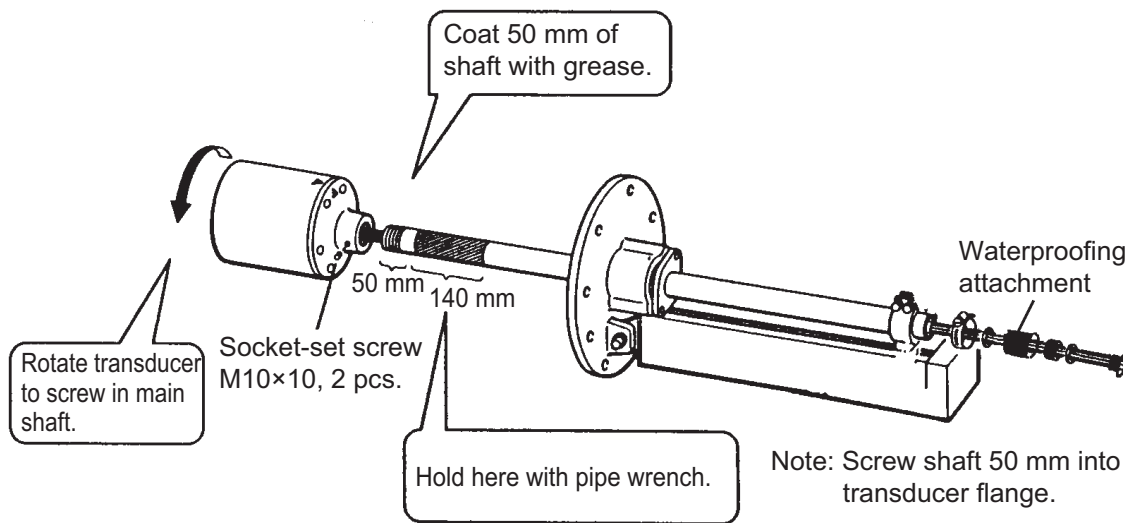

Fastening main shaft to transducer

- Clean the top of the shaft with alcohol, install the waterproofing attachment and apply Loctite (supplied) to the socket screw.

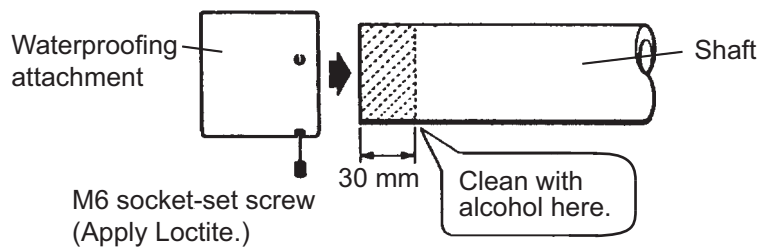

Cleaning the shaft

- Inscribe bow mark on the top end of the main shaft and install the fastening band, O-ring, waterproofing material, cable gasket, cable washer and fastening gland. Use two socket-set screws (M6×8) to fasten the waterproofing material.

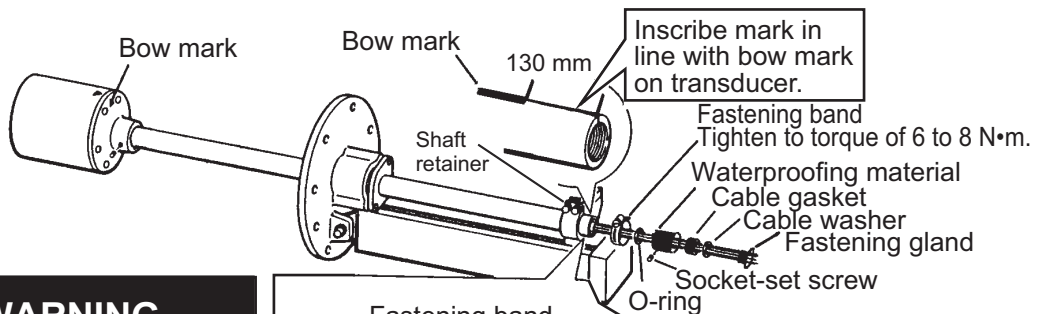

⚠ WARNING

When assembling the hull unit, fasten the fastening band with the torque of 6 to 8 N•m.

If torque is less than the above, water leakage may occur because the shaft may loosen and fall.

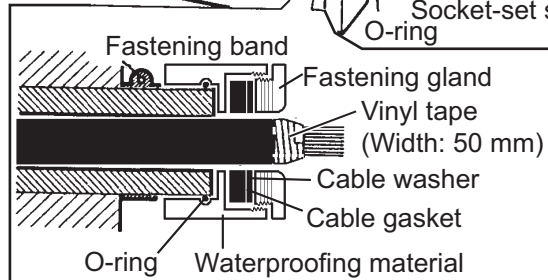

Installing fastening band and cable gland

Note: Tighten socket-set screws to torque of 3.92 N•m to 4.90 N•m.

8. Install grease cotton on the main body as below.
 - a) Wind grease cotton onto main shaft.
 - b) Mark on the cotton as below.
 - c) Remove the cotton from the shaft, and then cut it at the position of the mark. Discard the ends.
 - d) Wind grease cotton as shown below.
 - e) Push grease cotton into the main body flange.
 - f) Tighten the grease cotton retainer.

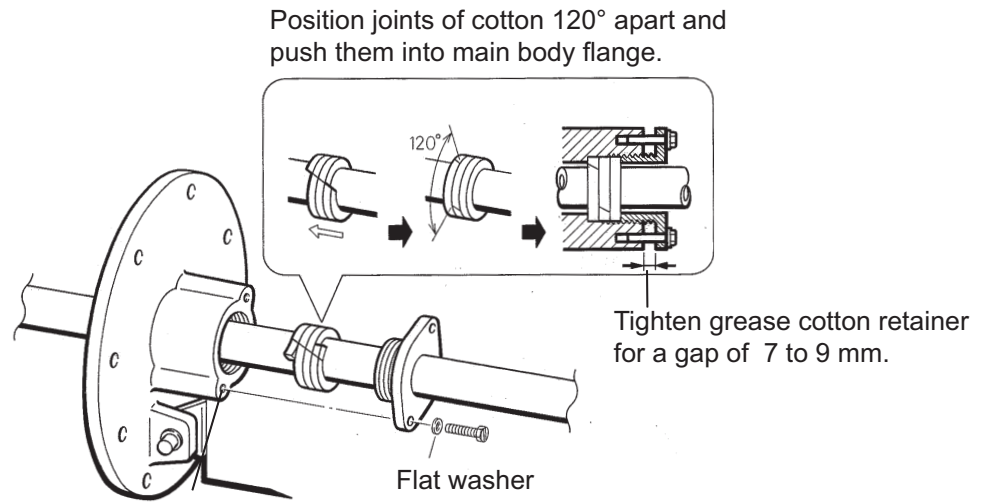

Setting grease cotton

9. Attach the tank guide.

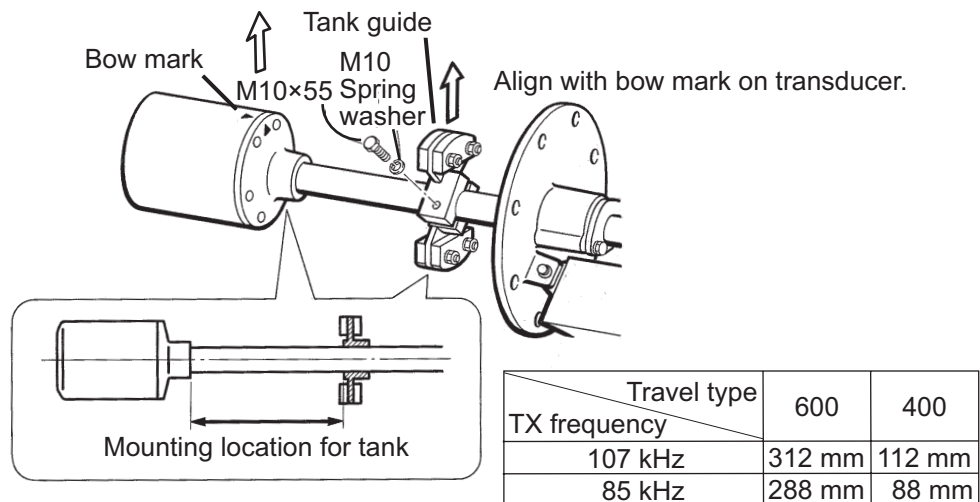

*: Measure between the top of the transducer flange and inner edge of the tank guide.

Installing the tank guide

1. MOUNTING

10. Attach zinc block (or propeller zinc assembly) to main shaft.

⚠ CAUTION

The zinc block (or propeller zinc assembly) near the transducer must be replaced yearly.

The junction between the transducer and main shaft may corrode, which can result in loss of the transducer or water leakage inside the ship.

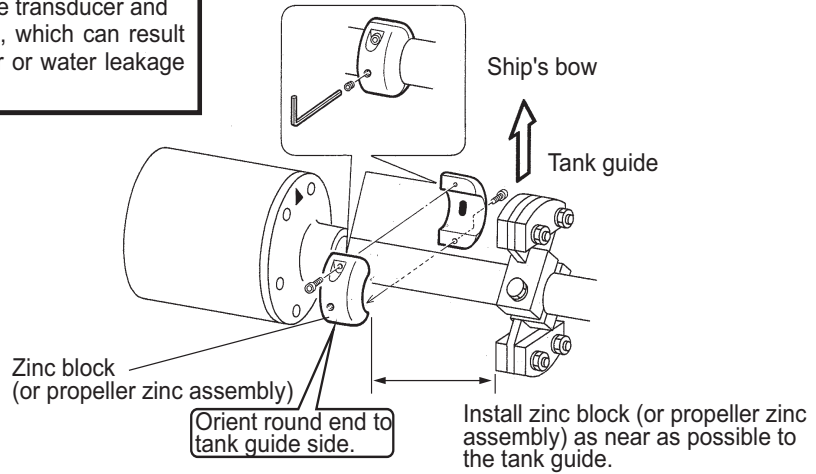

Attaching zinc block (or propeller zinc assembly)

11. Fasten the hull unit to the retraction tank.

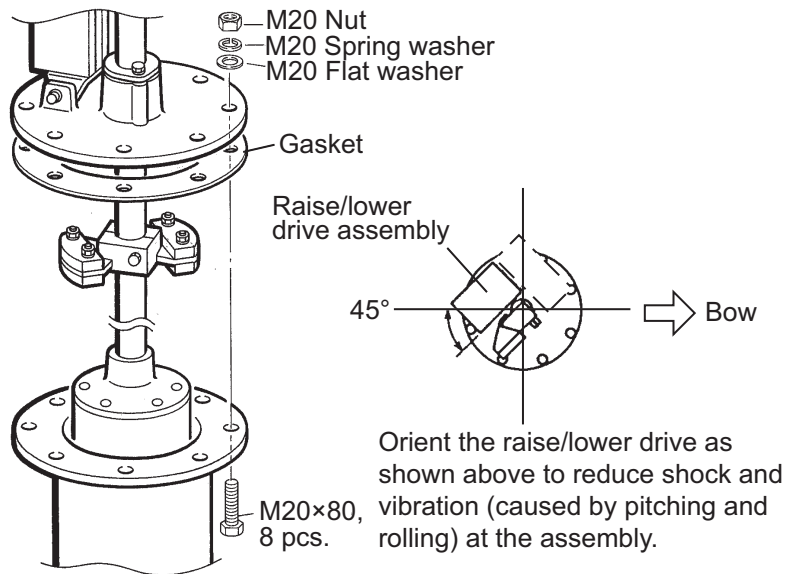

Fastening the hull unit to the retraction tank

12. Fix anti-vibration stays to the retraction tank.
 Anti-vibration stays should be fixed to directions of ship's bow – stern and port – starboard.

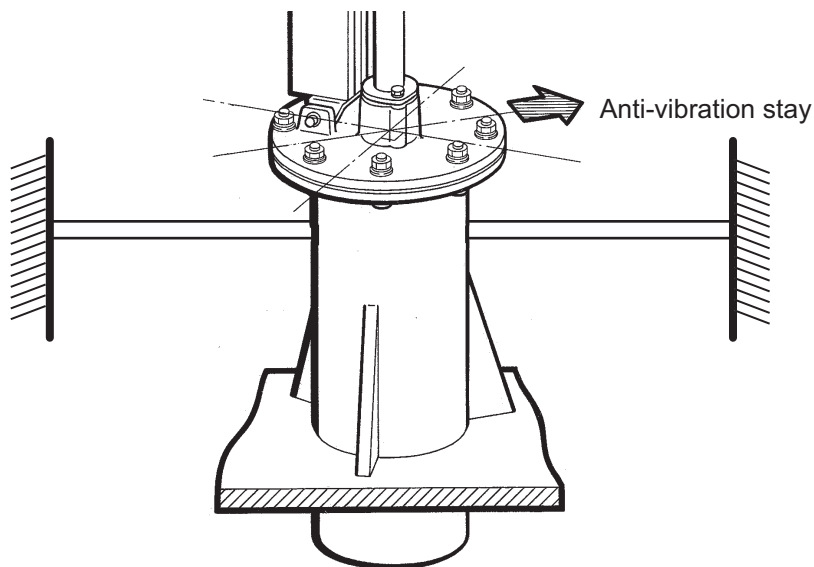

Fixing anti-vibration stays to retraction tank

13. Orient the main shaft so that the bow mark faces ship's bow and fix it securely with the shaft retainer.

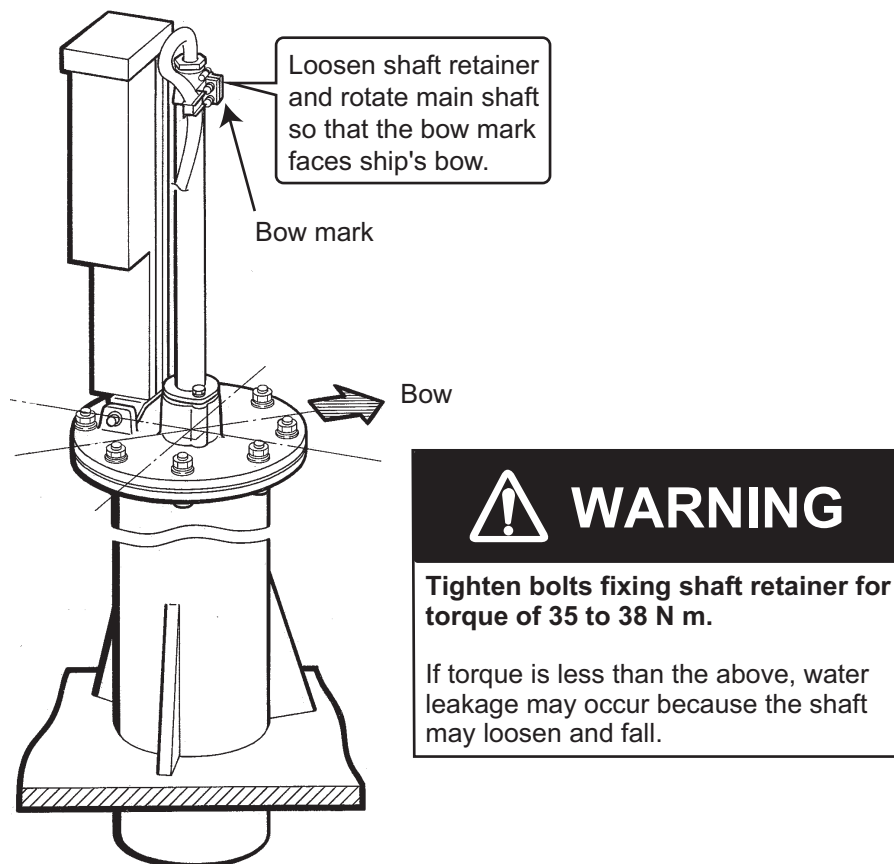

Orienting the main shaft

1. MOUNTING

HULL UNIT KIT

Name	Type	Code No.	Qty	Remarks
Raise / Lower Drive Assembly	–	–	–	Specifications according to order.
Transducer	–	–	–	
Main Shaft	–	–	–	
Retraction Tank	–	–	–	
Main Body Flange	10-044-2201	100-112-540	1	
Grease Cotton	9.5SQUARE *0.7M*	000-801-891	1	
Fastening Band	2×SUS304	000-801-924	1	
Tank Guide	CSH-504*/804*/703*	006-979-160	1	
Hex. Bolt	M20×80 SUS304	000-801-893	8	
Flat Washer	M20 SUS304	000-864-135	16	
Spring Washer	M20 SUS304	000-864-270	8	
Hex. Nut	M20 SUS304	000-863-116	8	
Connector Puller	10-044-2431	100-122-480-10	1	
Cable Fixing Band	HP-18N	000-162-504-10	5	
	HP-5N	000-162-508-10	2	
Socket Screw Wrench	HEX. SIZE 3 mm	000-830-131	1	
Zink Block	CSH-5	000-802-966	1	Either one is included.
Propeller Zinc Assembly	10-078-5105-0	100-421-830-10	1	
Water Proofing Metal	10-067-3221-1	100-273-901	1	For waterproofing main shaft
Cable Gland	10-067-3222-1	100-273-901	1	
Gasket	10-067-3223-1	100-273-911	1	
Flat Washer	10-067-3224-0	100-273-930	1	
O-ring	JISB2401-1A-G55	000-851-308	1	
Hex. Socket Head Screw	M6×8	000-851-308	1	
Junction Box	10S1982	000-808-747	1	
Junction Box Fixing Plate	10-067-3103	100-272-661	1	

1.1.4 Confirmation of transducer movement

After you have installed the hull unit, confirm that the transducer moves upward/downward smoothly by using the ratchet wrench.

Note: When lowering the transducer, confirm that there is enough space below the ship's bottom.

⚠ CAUTION

Turn off the POWER switch on the hull unit before manually raising or lowering the transducer (with the ratchet wrench).

Bodily injury can result if the ratchet wrench rotates unexpectedly, because the raise/lower motor may start up.

1. Turn off the POWER switch on the hull unit.
2. Remove four screws (M4×8) to remove the gear cover.

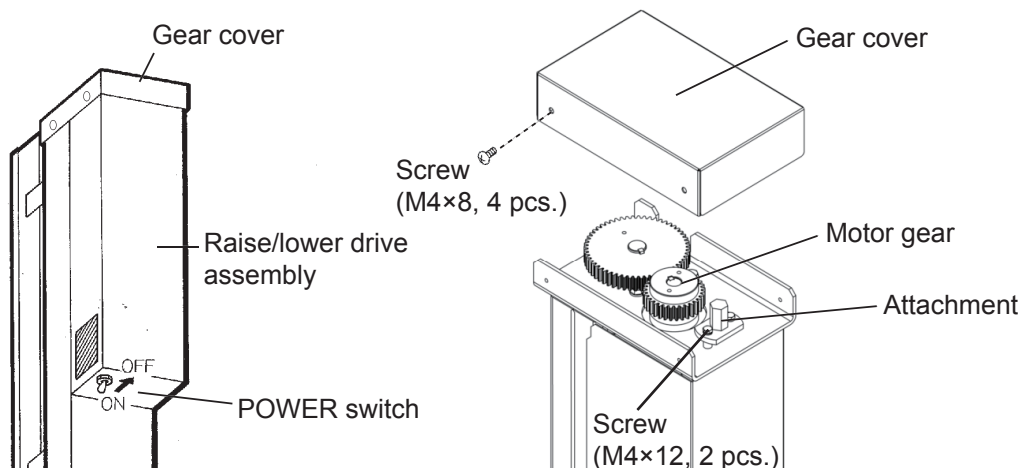

3. Remove two screws (M4×12) to unfasten the attachment.
4. Fasten the attachment onto the motor gear with the screws removed at step 3.
5. Turn the attachment in both clockwise and counterclockwise directions with the ratchet wrench. Confirm that the transducer moves upward/downward smoothly.

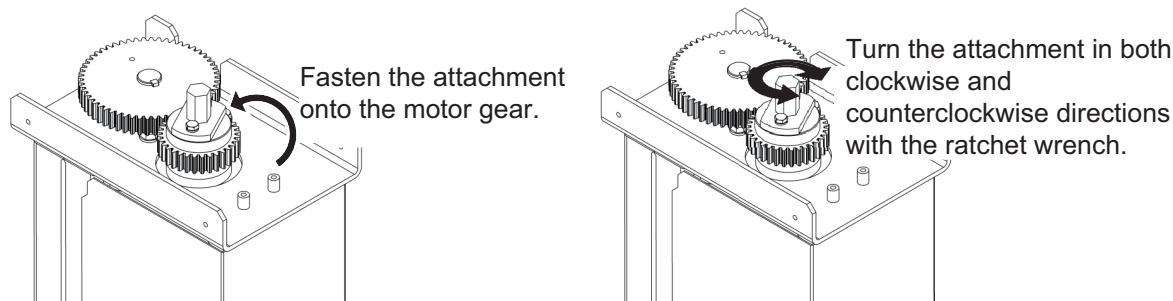

1.2 Transceiver Unit

- The transceiver unit generates heat so the mounting location should be well ventilated and dry.
- The unit is only designed for bulkhead mounting. The unit weighs 40 kg so reinforce the mounting location if necessary.
- The length of the cable between the hull unit and the transceiver unit is 5 or 10 m, and the length of the transducer cable is about 6 m. Determine mounting location considering these cable lengths.
- Secure the maintenance space shown in the figure below for ease of maintenance and service.

Fasten the transceiver unit to the mounting location with M10 bolts and nuts.

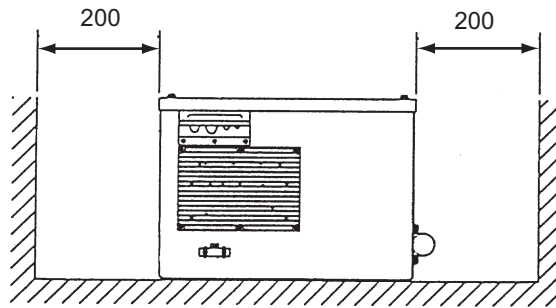
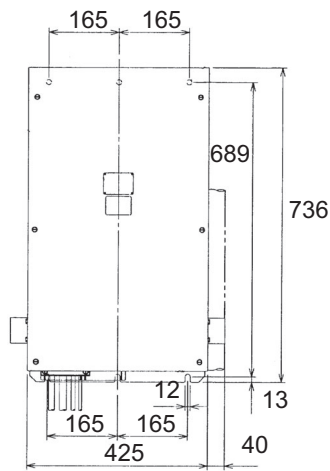

Cable clamp attached at right side of unit at default. You can change the position to left side.

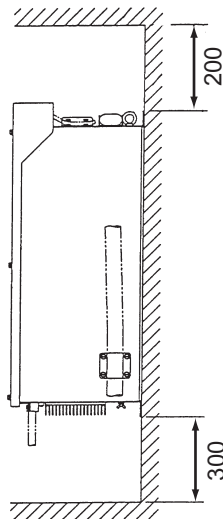

Transceiver unit, mounting dimensions

1.3 Processor Unit

Fasten the unit with four M6 bolts or tapping screws. For location, consider the length of the following cables.

- Cable between processor unit and monitor unit: Max. 10 m
- Cable between processor unit and transceiver unit: Max. 50 m

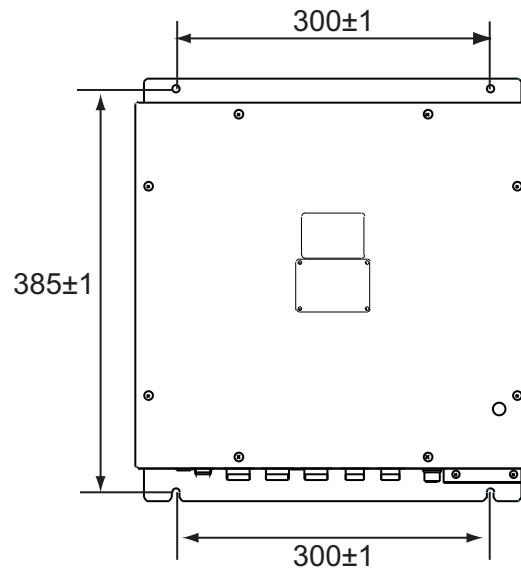

Processor unit mounting, dimensions

1.4 Control Unit

The control unit may be permanently mounted on a desktop, with or without the KB fixing plate (supplied as accessories), which tilts the control unit at 15° angle. Also, the rubber feet can be used when the unit not permanently fixed.

1.4.1 Non-permanent mounting

Attach four rubber feet (supplied) at the bottom of the control unit, and then place the unit on the selected location.

1.4.2 Permanent mounting

The control cable can be passed from the hole at the bottom of the control unit.

Installing with the KB fixing plate

1. Attach the connector sticker to the unused cable hole.
2. Fix the KB fixing plate (supplied as accessories) to the bottom of the control unit with two hex. bolts (supplied).
3. If necessary, make a hole of diameter 30 mm through the desktop to pass the control cable from the bottom of the control unit.

1. MOUNTING

4. Fasten the KB fixing plate with two tapping screws ($\phi 6.5$, local supply).

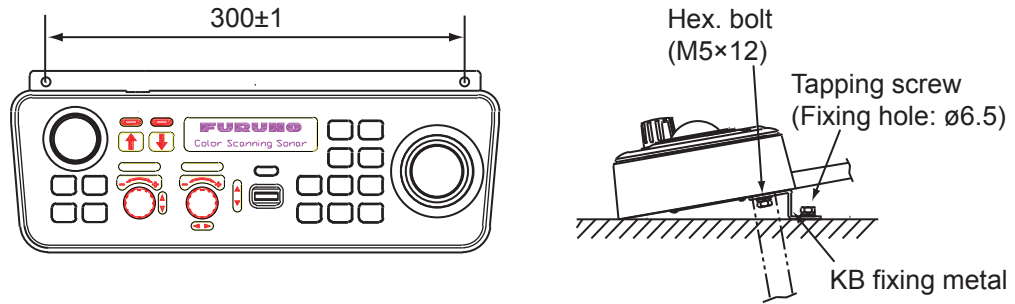

How to attach KB fixing plate

Installation without KB fixing plate

1. Make four holes of 6 mm in diameter referring to the figure below.

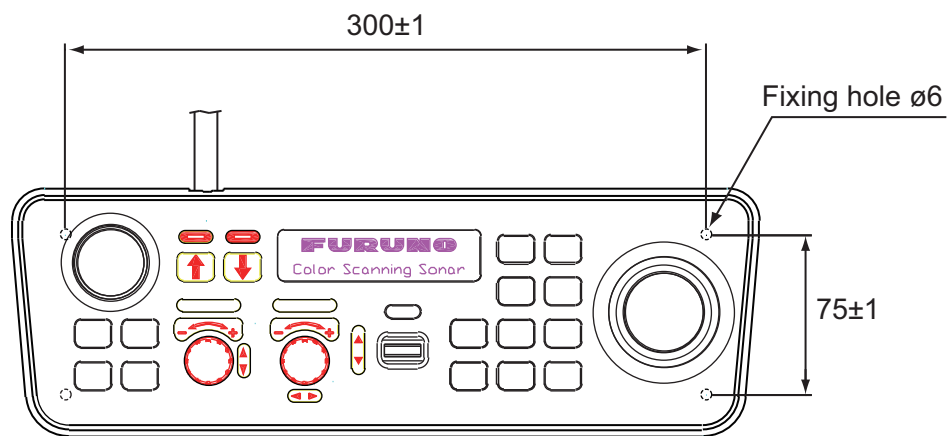

Control unit, dimensions for directly mounting

2. Make an indentation in the desktop to accommodate the nameplate (approx. 2 mm thickness) at the bottom of the control unit.
3. If necessary, make a hole 30 mm in diameter in the tabletop to pass the control cable from the bottom of the control unit. To run the cable from the bottom of the control unit, see the next page.
4. Screw in four hex. bolts (M5×12, supplied as accessories) from the under side of the table to fix the control unit.
When the above bolts are not long enough, use locally supplied bolts, with their length the thickness of the desktop plus 5 to 8 mm.

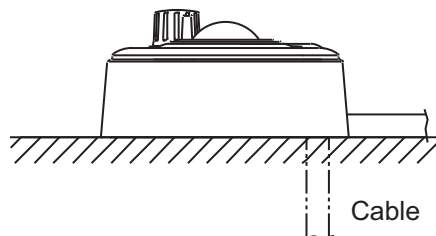

Mounting control unit directly

Changing the cable entrance location

1. Unfasten six screws (M4×8) at the bottom of the control unit.
2. Unfasten two screws (M4×10) fixing the cable clamp.
Discard these screws.
3. Unplug connectors from J1 and J2 on the KEY Board 10P6951.

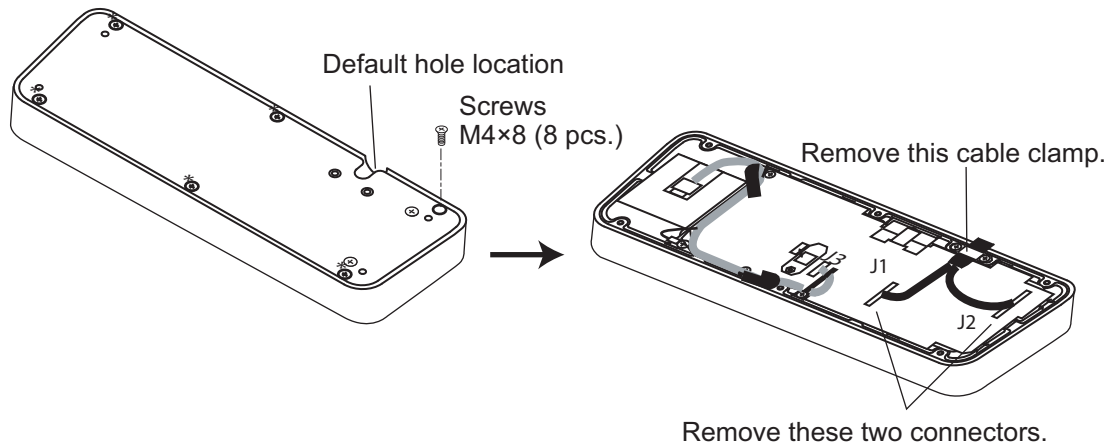
*Control unit*

4. Attach the cable clamp removed at step 2 with two screws, spring washers, flat washers and nuts (supplied with accessories) to fix the control cable shown below.

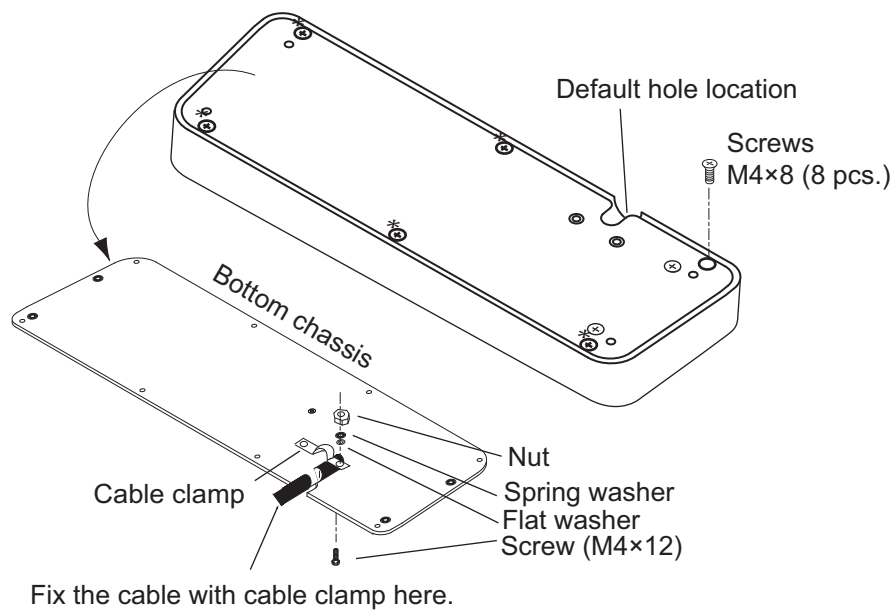
*Control head*

5. Reattach connectors J1 and J2.
6. Fasten six screws to assemble the control unit.

1.5 Ground

Ground the equipment with copper straps (supplied) or earth wire as appropriate.

Note: If the ground is not proper, operation error or noise-filled video may result.



CAUTION



Attach protective earth (ground) securely to the ship's body.

The protective earth (ground) is required for the transceiver unit and DC-AC inverter (option) to prevent electrical shock.

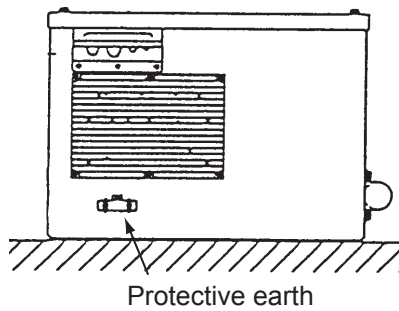

Transceiver unit

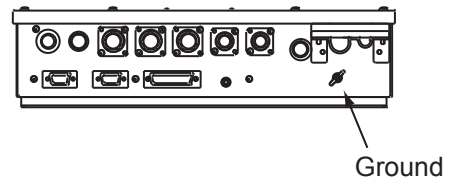

Processor unit

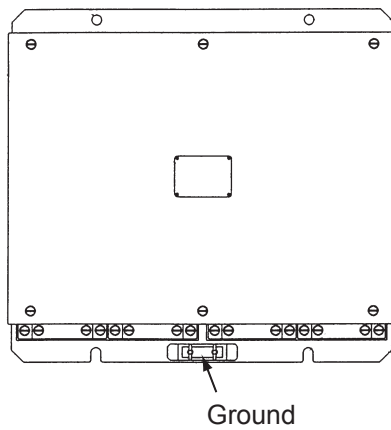

Junction Box

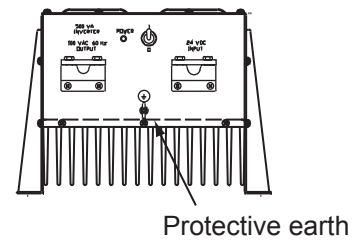

DC-AC inverter

1.6 Transducer Cable Extension Kit CSH-1700 (Optional Junction Box)

This optional kit provides for extension of the transducer cable by 6.6 m, and can be mounted on a deck or the bulkhead. Determine mounting location considering length of cable assy. Maintenance space around the unit should be as shown below.

Name: Transducer cable extension kit, Type: CSH-1700, Code No.: 000-068-207

Name	Type	Code No.	Qty
Junction box	CSH-1700	006-800-000	1
Cable assy	10S1950	000-141-817	6.6 m

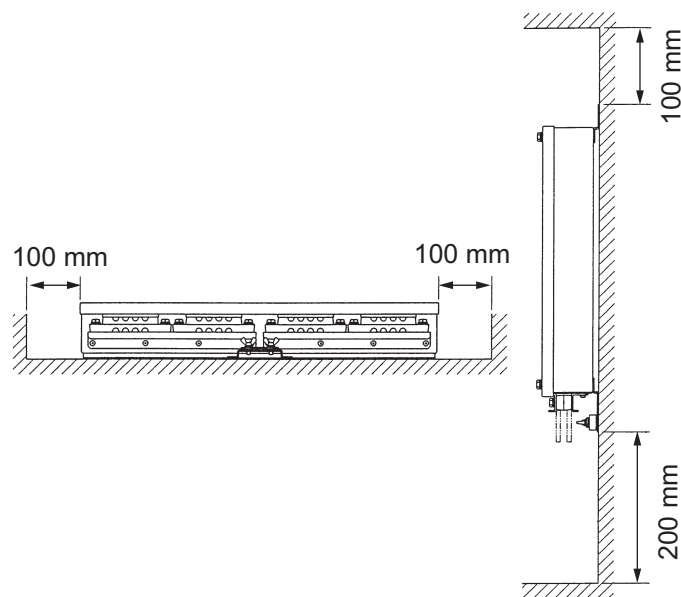

Junction box

1.7 Motion Sensor MS-100 (option)

The optional motion sensor MS-100 measures ship's pitching and rolling angles with a sensor, using the principles of the gyrocompass. Because it is free from error caused by ship's vertical and horizontal motion, it can be installed at any convenient location. However, ship's semi-permanent inclination due to loading imbalance be detected.

1.7.1 Mounting considerations

- Vibration in the mounting area should be minimal.
- Locate the unit away from areas subject to water splash.
- The ambient temperature should not exceed 50°C.

1. MOUNTING

1.7.2 Mounting procedure

Orient the FORE mark on the unit toward the ship's bow and mount the unit within 5° of horizontal in all directions. For the offset, see Chapter 3.

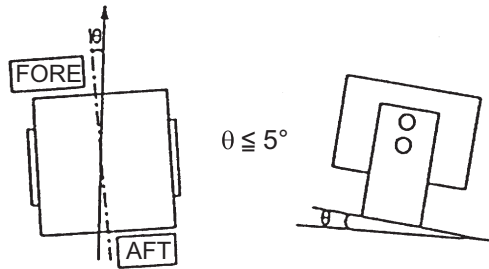

Mounting the motion sensor MC-100

1.8 DC-AC Inverter (option)

The optional DC-AC inverter is required when the ship's mains is 24 VDC. The DC-AC inverter should be mounted on a bulkhead (weight of unit: 15 kg) with sufficient vibration. Install the unit so that the cable entrances are facing downward.

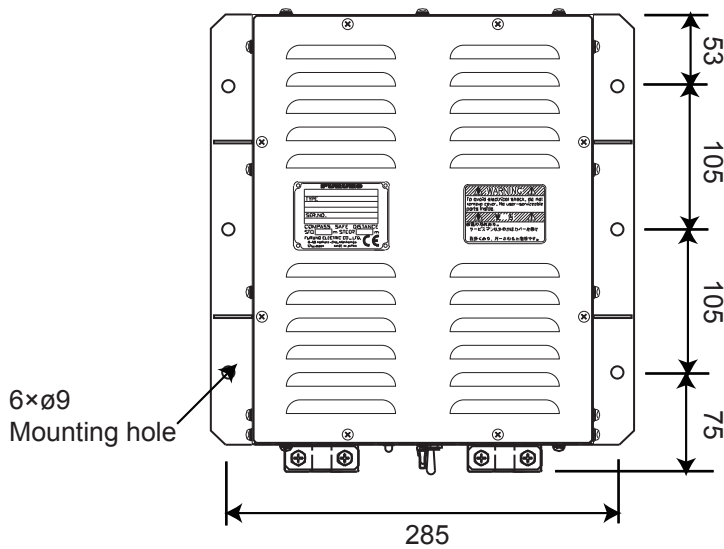

DC-AC inverter

2. WIRING

2.1 Cabling Outline

Cabling between processor unit and transceiver unit

The cable between the processor unit and transceiver unit comes in lengths of 15 m, 30 m or 50 m. A connector is pre-fitted at the factory for connection at the transceiver unit. Fit a connector to the other end of the cable. The cable may be shortened as necessary.

Cabling between the transceiver unit and hull unit

Connectors are pre-fitted at the factory. The length of the cable is 5 or 10 m.

Transducer cable

A connector is pre-fitted for connection to the transducer. Attach a connector to the other end of the cable for connection to the transceiver unit. For cable extension, use the optional transducer cable extension kit. It enables extension of the transducer cable up to 6.6 m.

2. WIRING

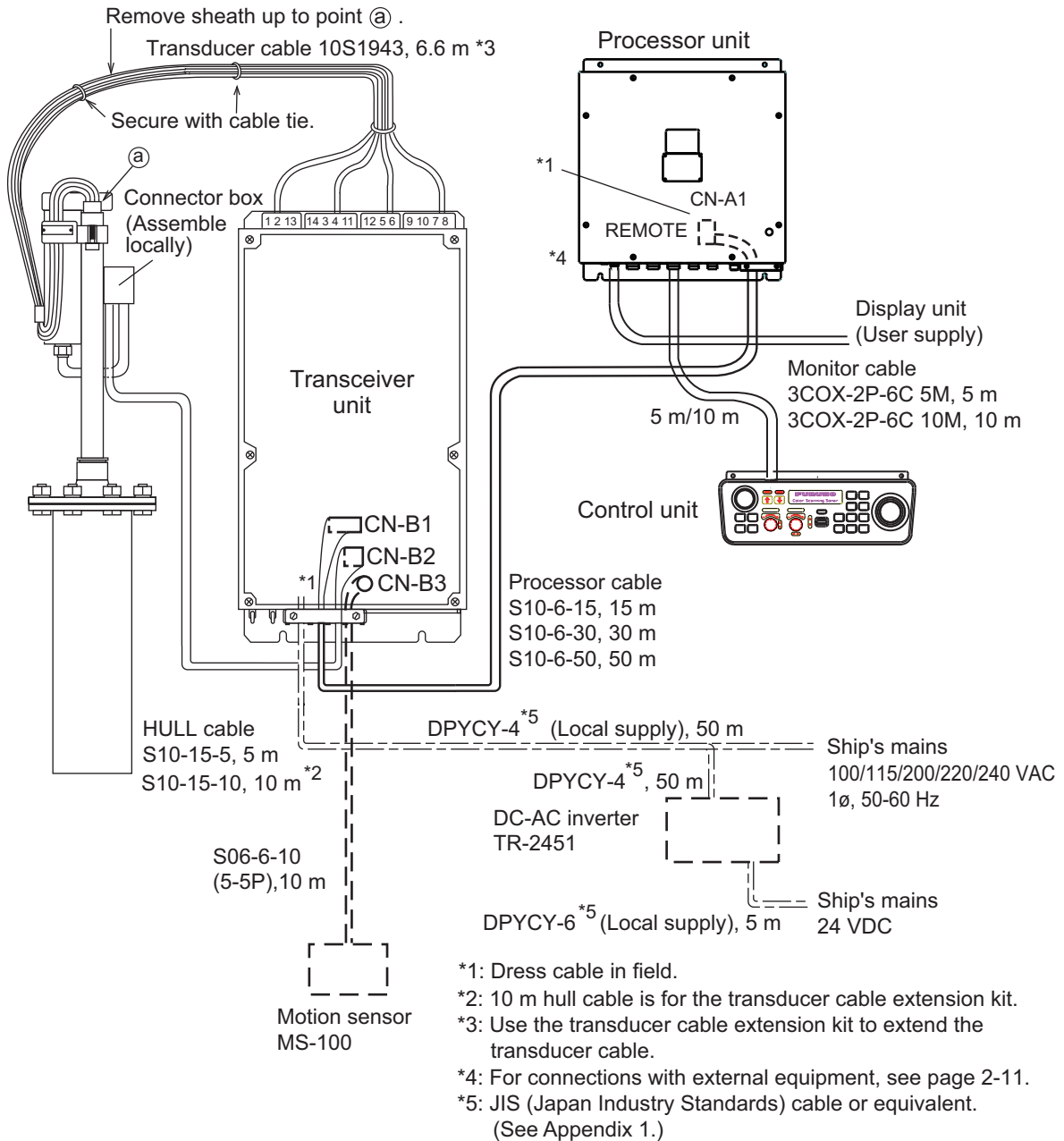

Wiring diagram

2.2 Hull Unit

2.2.1 Wiring of transducer cable

Wire the transducer cable (14 cores) as below to prevent undue stretching during raising or lowering operation. Fix the cable with the cable clamp on the raise/lower drive assy.

1. Run the cables referring to the following figure, then fix them with cable clamp [A]. After fixing the cables, bundle them using cable ties (supplied locally). As a guide-line for position of the cable tie, if the height from the top edge of waterproofing gasket to the top of the cable loop is "H", two places when "H" < 100 mm and three places when $100 \text{ mm} \leq "H" \leq 150 \text{ mm}$.

Note: Run the cables without slack so that the cables does not get caught when lowering/raising the transducer.

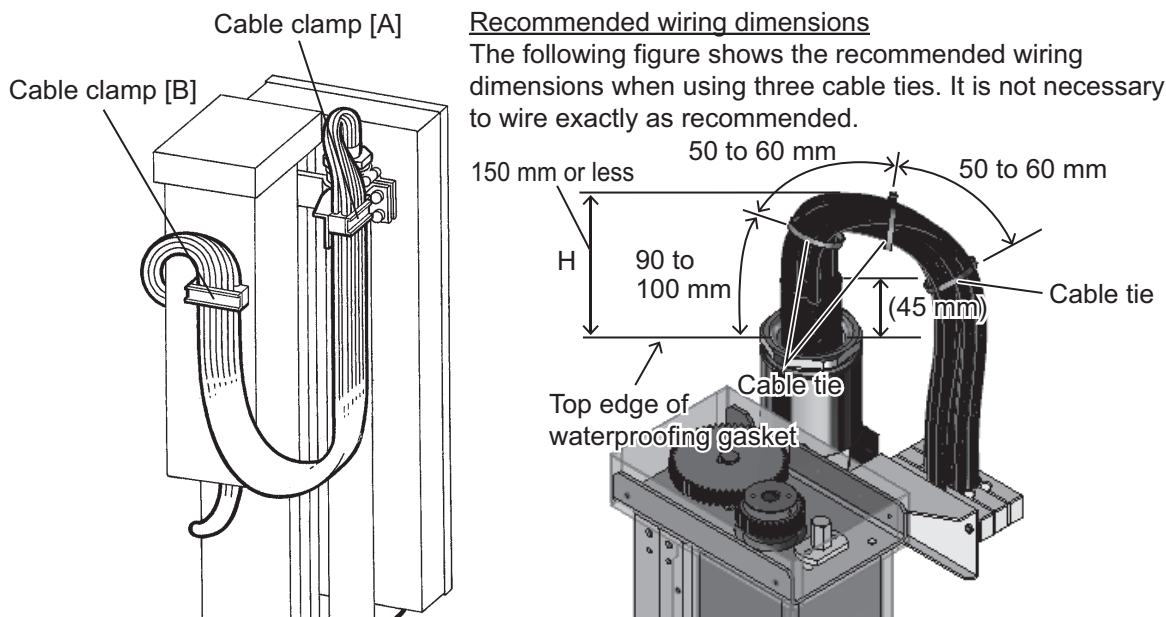

Hull unit, cable clamp

2. Run the cables to cable clamp [B] on the raise/lower drive assy and position it as shown below. Temporarily tighten clamp [B].

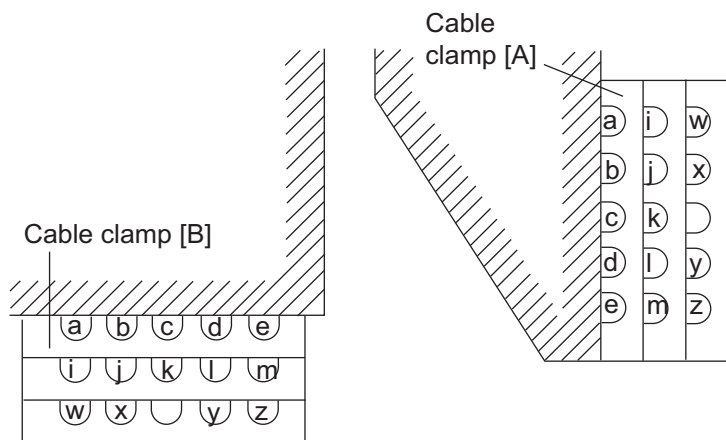

Example: Wire Ⓐ of clamp [A] to Ⓐ of clamp [B].

Cable clamps and positioning of cables

2. WIRING

- Adjust the cable lengths between cable clamps [A] and [B] as follows:

	600 stroke	400 stroke
Between (a) of clamp [A] and (a) of clamp [B]	660 mm	580 mm
Between (i) of clamp [A] and (i) of clamp [B]	690 mm	610 mm
Between (w) of clamp [A] and (w) of clamp [B]	720 mm	640 mm

- Adjust slack of 11 other cables so it is the same as the ones adjusted at step 3, and then tighten the clamps [A] and [B].

2.2.2 Connector box for hull unit cable

Fasten the connector box on the side of the hull unit opposite the cable clamp [B]. Its purpose is to act as relay for the cable which sends control signals from the transducer unit to the hull unit. Be sure to run the thinner cable to the direction opposite to the raise/lower drive assy as shown in the figure below.

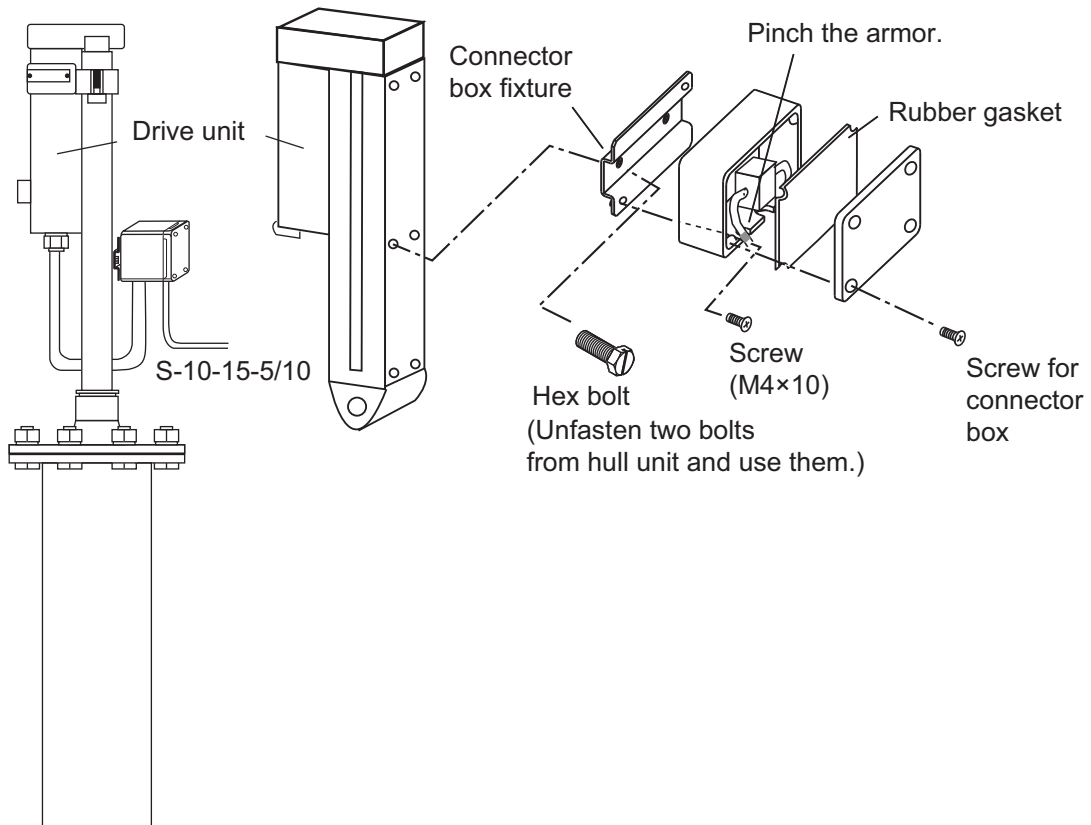

Hull unit, connector box

- Unfasten two hex bolts from the hull unit and use them to fasten the connector box fixture to the hull unit.
- Fasten connector box to the connector box fixture with two screws.
- Connect connector MLP-15 from the drive section to the connector ELR-15 (or MLR-15) at the end of the S10-15-5 (or S10-15-10) from the transducer unit. Set the cable in the connector box.
- Fasten the lid of the connector box with four screws so that lid pinches the armor of the cable.
Remember to insert the rubber gasket.

2.3 Transceiver Unit

Except the power cable, all cables connected to the transceiver unit are pre-fitted with connectors.

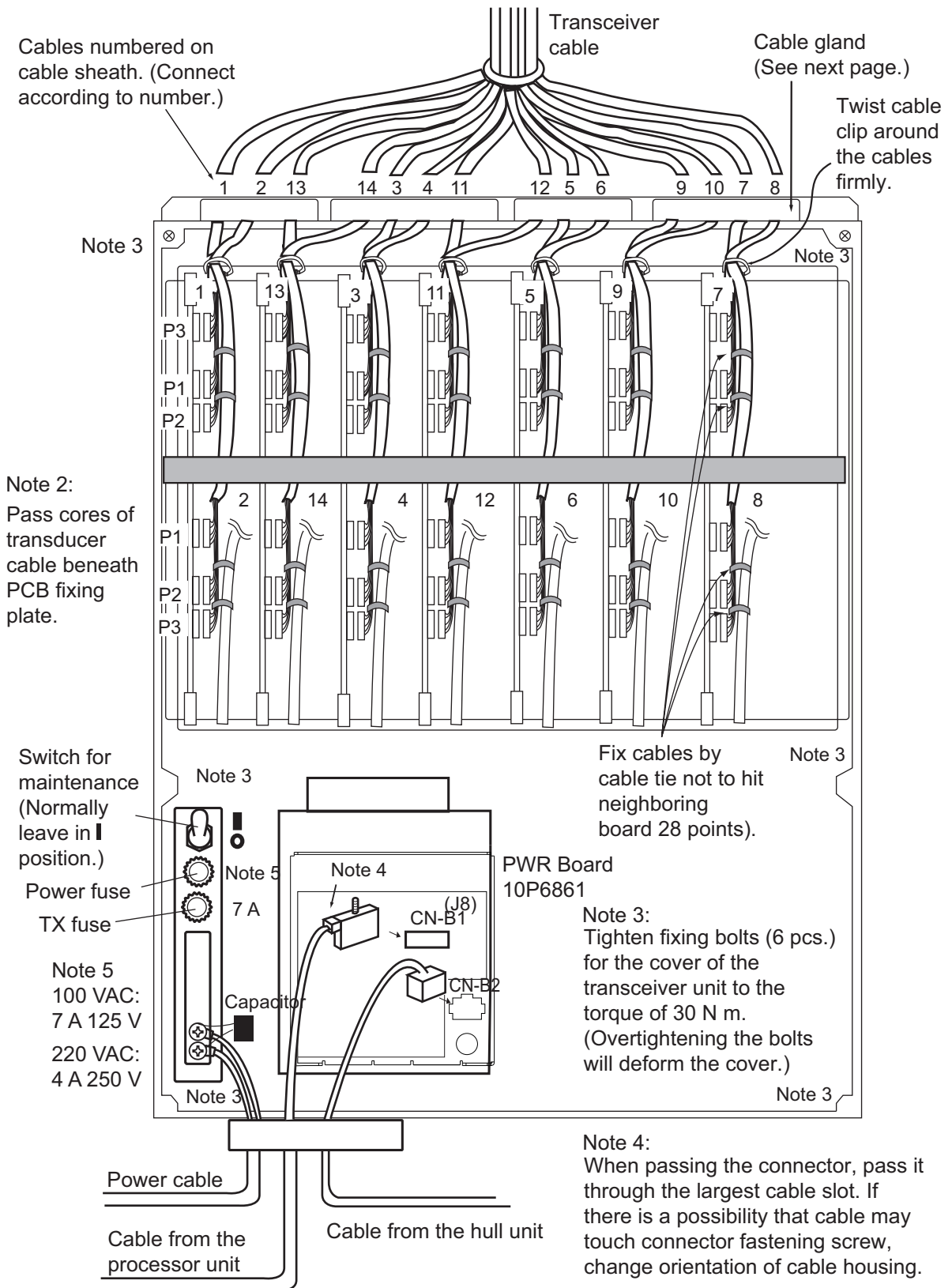

Wiring in transceiver unit

2.3.1 Transducer cable wiring

Separate the cable in two, pass it through cable clamp [A] and fix it with a cable tie. Pass the cable through cable clamp [B] and fix with cable tie. Pass cable through cable clamp at the side of the transceiver unit.

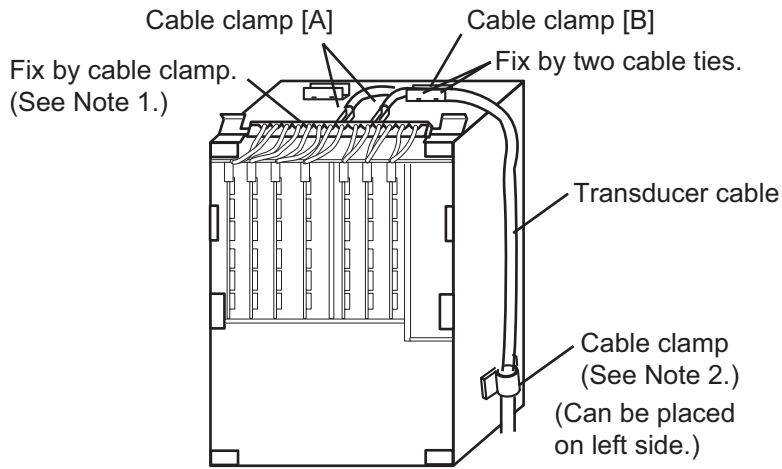

Transceiver unit, upper view

Note 1: Wire unit with cable clamps in horizontal position. Lay cable clamp after finishing wiring.

- 1) Lay braided shields of transducer cable in cable clamp. Each cable is numbered; connect referring to the illustration on the preceding page.
- 2) Unfasten two bolts.
- 3) Set the clamp and fasten it with two bolts removed at step 2.

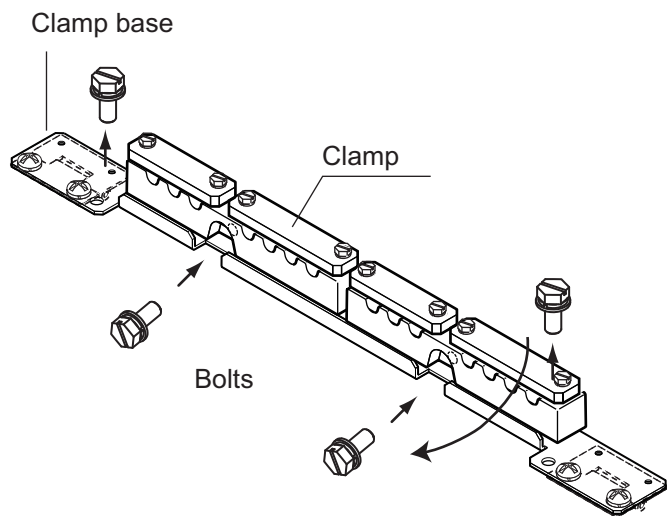

Note 1: When fixing transducer cable with cable clamp, wrap with vinyl tape before fixing, or wrap the cable with a piece of the outer sheath of the cable and fix by cable clamp.

2.3.2 Power cable

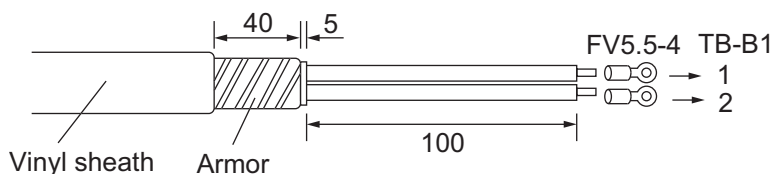

Fabrication of power cable

Note: When connecting the power cable, the crimp on lug of the capacitor is removed. Do not forget to reattach the crimp on lug of the capacitor to the terminal board.

2.3.3 Changing the power specification

Change jumper wires on the transceiver unit according to ship's mains. Follow the label on the power block in the transceiver unit. Attach the other end of the wire plugged in #3 (COM) into one of #4 (100 V) thru #8 (240 V) depending on ship's mains. Also, change the power fuse appropriately. On the stickers at the terminal board and back of the front lid of the transceiver unit, change the mark position for the used fuse.

Ship's mains	Fuse
100 VAC series (100/110/115 VAC)	7 A 125 V
220 VAC series (200/220/240 VAC)	4 A 250 V

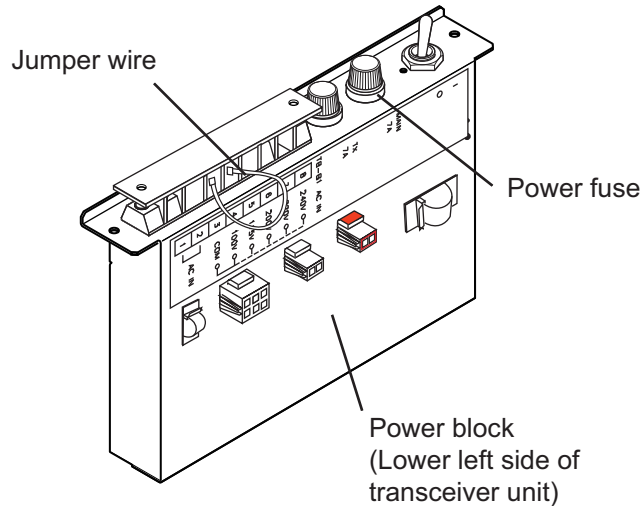

Transceiver unit power block

2.3.4 How to unplug the XH connector

If making a wrong connection of XH connector, use XH connector remover to unplug the XH connector.

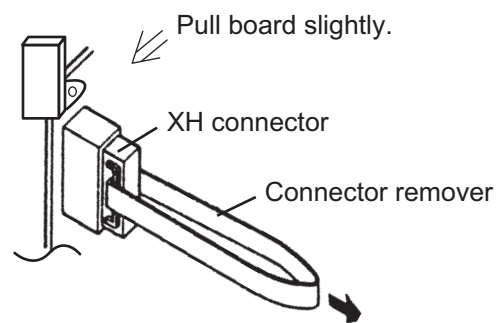

XH connector remover

2.4 Processor Unit

2.4.1 Wiring with transceiver unit

Attach a 38P connector to the end of the cable connected to the processor unit. Plug in this connector to CN-A1 on the MAIN Board.

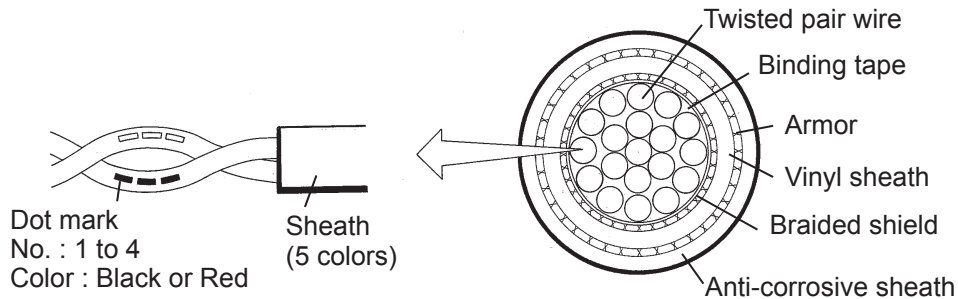

Construction of cable between processor and transceiver units

Fabricating cable between processor and transceiver units

Remove the anti corrosive sheath, armor and vinyl sheath as shown below.

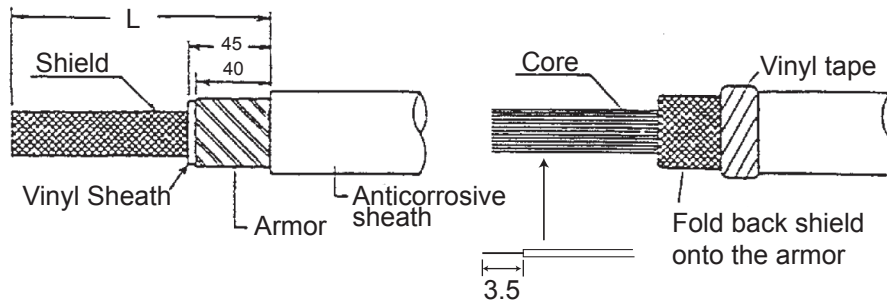

Fabrication of cable between processor and transceiver units

Connecting contact pins

A special crimping tool is necessary for connection of wires to the contact pins of the 38P connector. In addition, a pin extractor should be used to remove the contact pin from the connector housing.

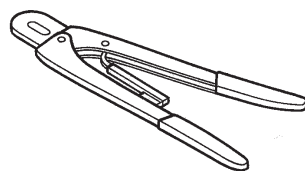

Crimping tool

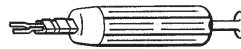

Pin extractor

How to use the crimping tool

1. Strip the vinyl sheath of the wire to expose the core by 3.5 mm.
2. Hold the crimping tool horizontally and insert the contact pin with its slit facing downward into the crimp hole on the crimping tool.
3. Insert the wire onto the contact pin and squeeze the handle until the ratchet releases.
(Place wire deep enough into the contact pin so that its end comes contact with the stopper plate of the crimping tool.)
4. With crimping completed, pull the wire while holding the contact pin to make sure that it is fastened tightly.

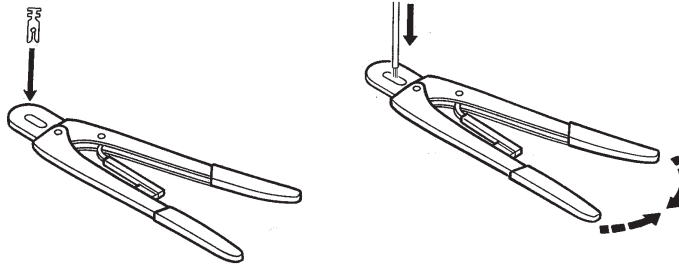

How to insert contact pin

Inserting contact pin into connector housing

Insert wires fitted with contact pins into the connector housing referring to the drawing below or the interconnection diagram at the back of this manual.

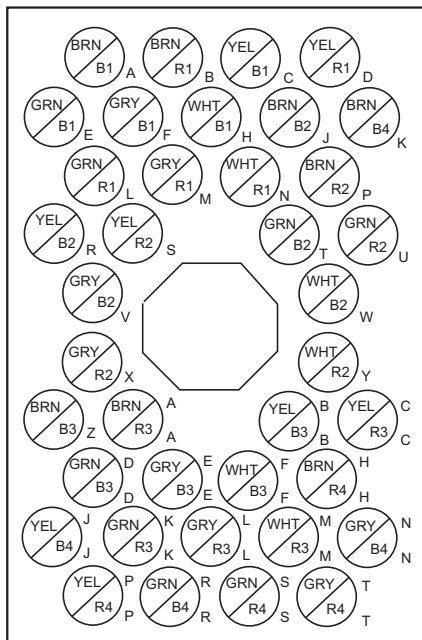

Note: 1. Wire differentiation

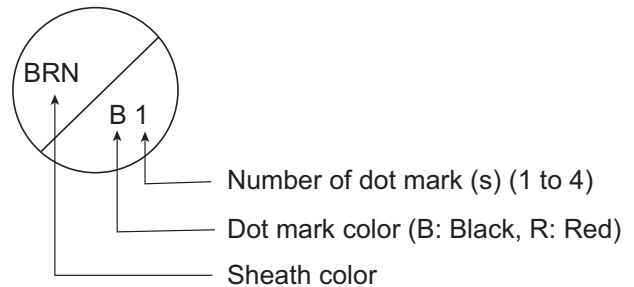

2. BRN and GRN show the following colors.
BRN: Light brown
GRN: Light green

3. Cover plate is not fitted to the connector.

Inserting contact pin into connector housing

How to use pin extractor

If a contact pin is inserted into an incorrect hole on the connector body, remove it with the pin extractor.

1. Push the pin extractor into the pin hole from the side opposite to the pin inserting side.
2. Push in the head of the pin extractor. The retaking spring comes free and the contact pin can be removed.

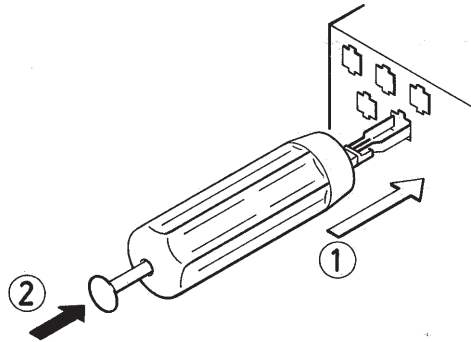

How to extract contact pin

Fixing the cable

Set shield and armor section in cable clamp and tighten cable clamp.

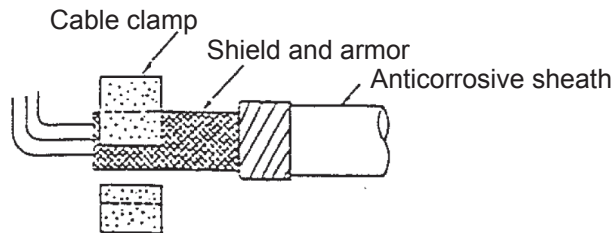

How to set cable in cable clamp

Other connections

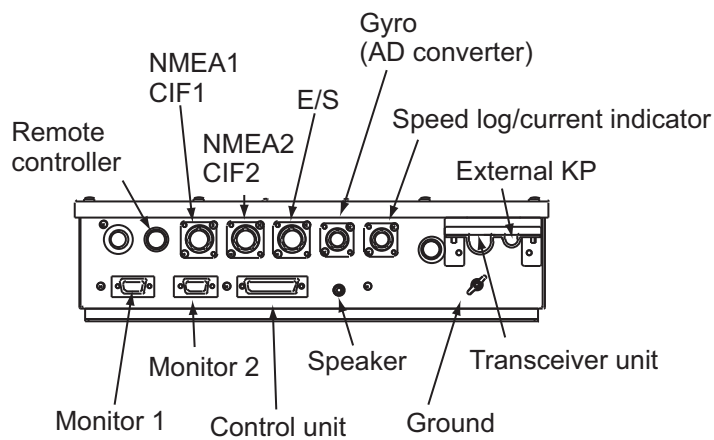

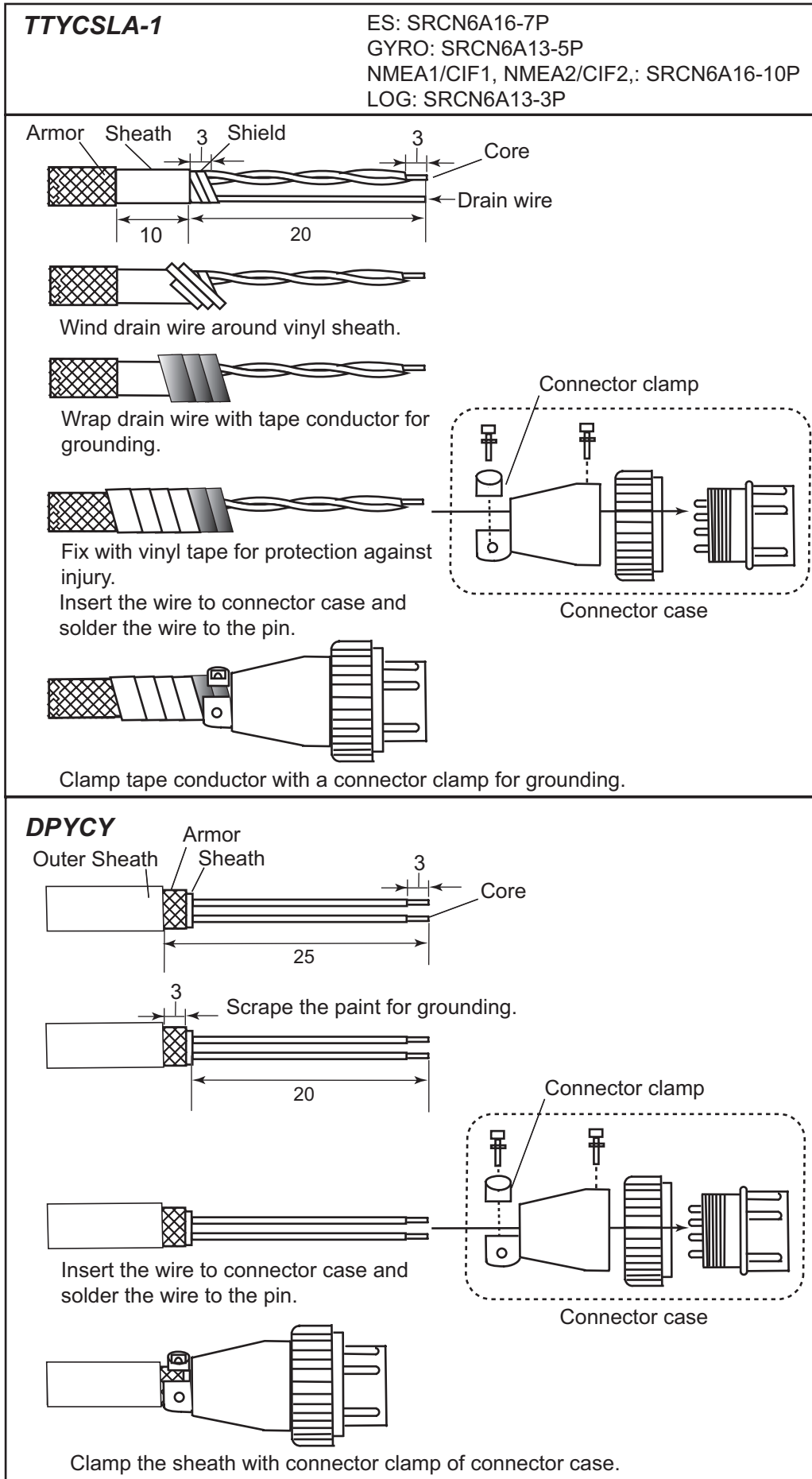

Fabricating of connectors for external equipment

Display unit

Prepare a XGA display locally. When using MU-150HD as the display unit, refer to its operator's manual. Connect the processor unit and display with the monitor cable 3COX-2P-6C 5 m or 10 m (supplied). Use the MONITOR 1 port for a display unit.

NMEA/CIF**NMEA input sentence**

Talker	Sentence	Information
*1	GAA	GPS position data
*1	GLL	Own ship position
**	GTD	Own ship position (TD, LOP)
LC	GLC	TD (Loran-C)
**	HDG	Heading (compass)
**	HDM	Heading (magnetic bearing)
**	HDT	Heading (true)
*2	VTG	Course over ground speed
VD	VHW	Water speed, heading
LC	RMA	Recommended minimum specific Loran-C data
*3	RMC	Recommended minimum specific GPS data
**	DBT	Depth below transducer, Ver. 1.5
**	DBS	Depth below sea level
**	DPT	Depth below transducer plus offset value, Ver. 2.0
**	MTW	Water temperature
VD	VDR	Water current, single layer
VD	CUR	Water current, multi-layers

*1: GPS navaid, Loran-C, II (other talker), TR

*2: GPS navaid, Loran-C, II (other talker), TR, VD

*3: GPS navaid, II (other talker), TR

** : Not specified

NMEA output sentence

Talker	Sentence	Information
SS	TTL	Target position (L/L)

CIF input sentence

Data No.	Information
21	DR position
24	Loran-C position
28	GPS position
54	Loran-C, TD
4:	Heading (true)
41	DR ship's speed and course
44	Loran-C ship's speed and course
48	GPS ship's speed and course
57	Depth of sea bottom
58	Water temperature
66	Current indicator ship's speed and course

Data No.	Information
56	Water current, single layer
76	Water current, multi- layers

CIF output sentence

Data No.	Information
5:	Target position (L/L)

Gyrocompass

Heading data from a gyrocompass can be inputted in AD-10 format via AD-100. For details, see the operator's manual for AD-100.

Echo sounder

Echo sounder data can be input from an echo sounder using the E/S interface VI-1100A. For details, see the installation materials for VI-1100A.

Speed log

Log pulse (contact signal) can be input.

2.5 Synchronizing Transmission with Other Equipment

2.5.1 Synchronizing transmission with another CSH-8L

When two CSH-8L are installed, connect them as shown below. This will synchronize the transmission of the No. 2 sonar with that of the No.1 sonar.

Wiring

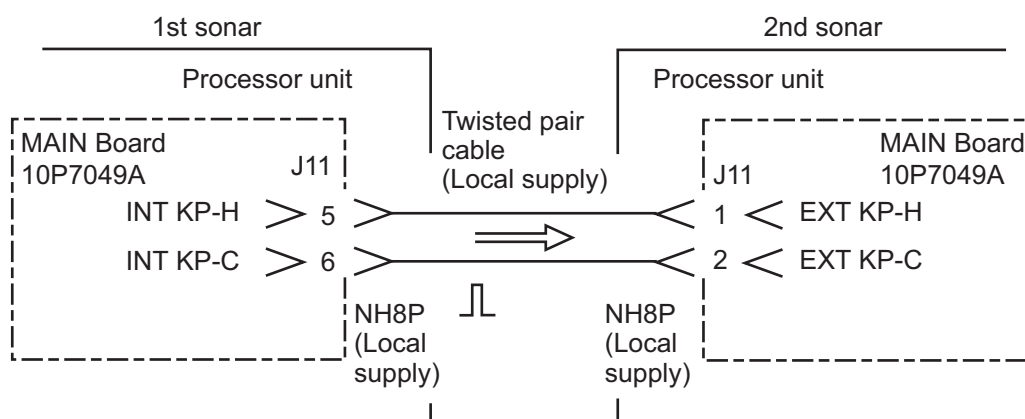

Connecting two CSH-8L

DIP switch setting

Set DIP switch #4 on the MAIN Board as follows:

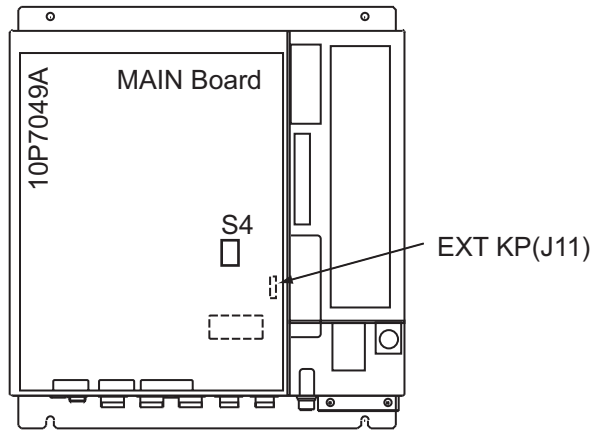

Processor unit, DIP switch S4 location

DIP switch	No.1 sonar	No.2 sonar
S4-#2	ON	-
S4-#1	-	OFF

When synchronizing No.2 sonar to No.1 sonar, set ON at [EXT KP SYNC] item on the setting menu. Refer to the operator's manual for the procedure.

2.5.2 Synchronizing with echo sounder or other sonar

To synchronize the transmission of the CSH-8L with an echo sounder or other type of sonar, make the connections shown below.

Wiring

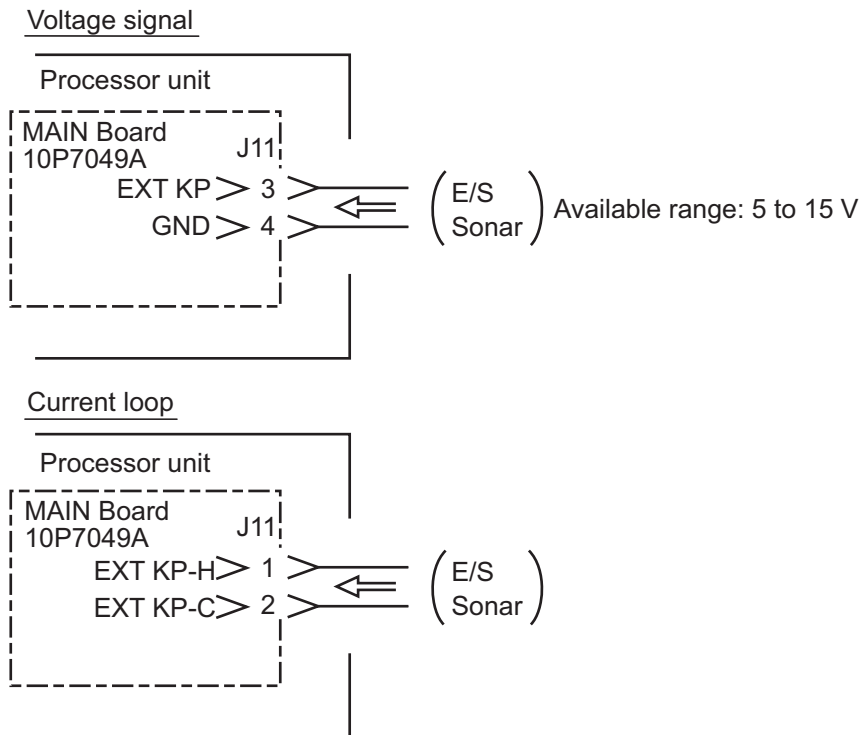

Connect of CSH-8L with E/S or sonar

DIP switch setting

Set DIP switch S4-#1 on the MAIN Board as follows:

Positive KP: OFF

Negative KP: ON

Menu setting

Turn ON menu item [EXT KP SYNC] in the System menu. Refer to the operator’s manual for the procedure.

2.5.3 Outputting KP of CSH-8L to echo sounder or other sonar

To output the transmission trigger (KP) of the CSH-8L to an echo sounder or other type of sonar, make the connections shown below.

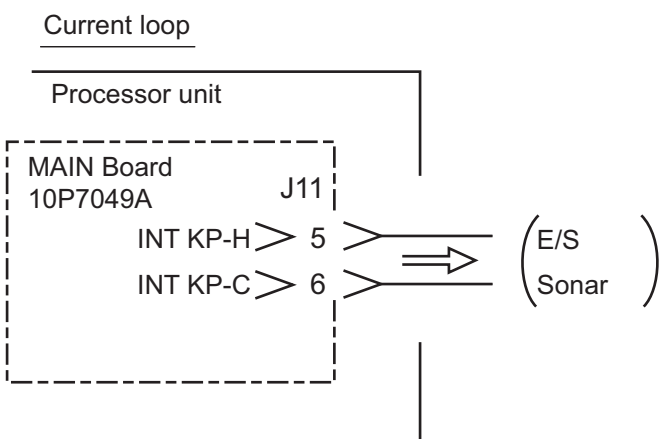
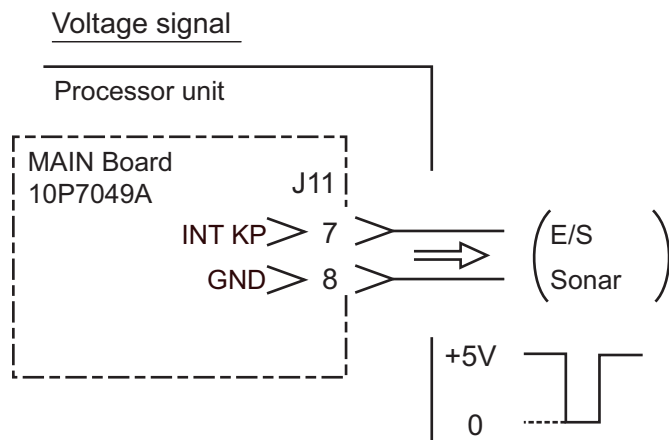

How to output CSH-8L’s KP to E/S or sonar

S4-#2	Transmitting trigger
OFF	Negative
ON	Positive

2.6 Transducer Cable Extension Kit (option)

The upper side of the cable clamp holds the transducer cable; the lower side the cable connected to the transceiver unit. Terminals for the transducer are numbered from the left side from 1 to 14. On the IN side of the circuit board, connect the cables from the transducer. Connect the cable to the transceiver to the OUT side. Fix even-numbered cables with cable clips.

Fix cable (10S1950) connected to transceiver unit at upper cable clamp.

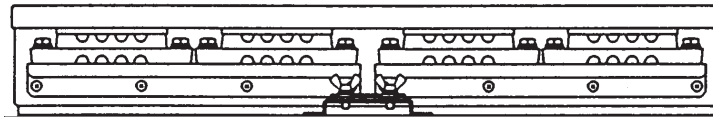

Fix transducer cable (10S1943) at lower cable clamp.

Junction box, side view

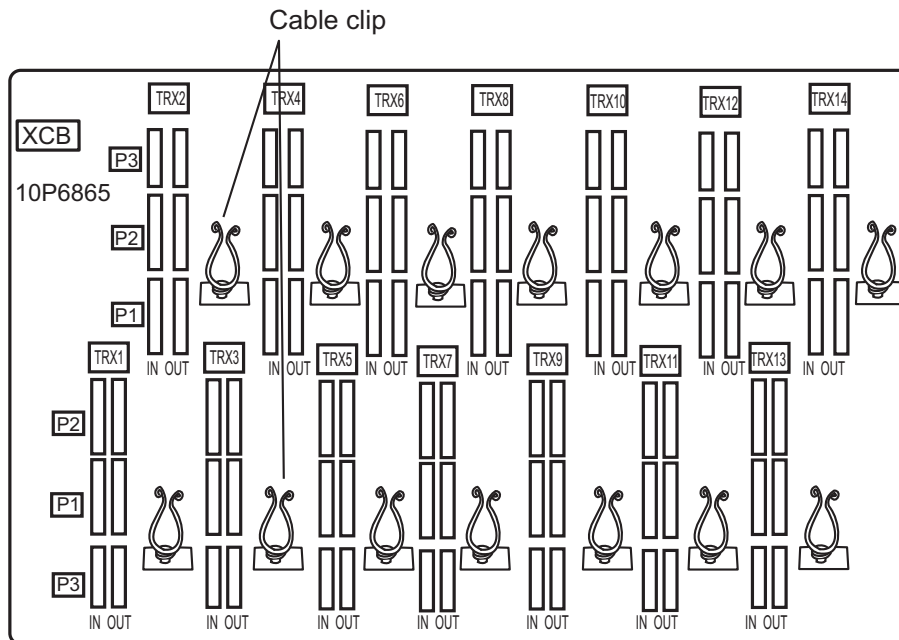

View from cable clamp

Junction box

Note 1: Plug in connectors firmly and fix cables with cable clips. Connectors may become disconnected and interference may result if this is not done before replacing the cover.

Note 2: Note that P1 and P2 connectors share the same shape and same pin number.

Note 3: If false echoes appear after installation, check connectors and the junction box.

2.7 DC-AC Inverter (option)

Use the JIS (Japan Industrial Standard) cable DPYCY-6 or equivalent (max. 5 m) between the ship's mains and the DC/AC inverter. For output (100 VAC), use JIS (Japan Industrial Standards) cable DPYCY-4 or equivalent (max. 50 m).

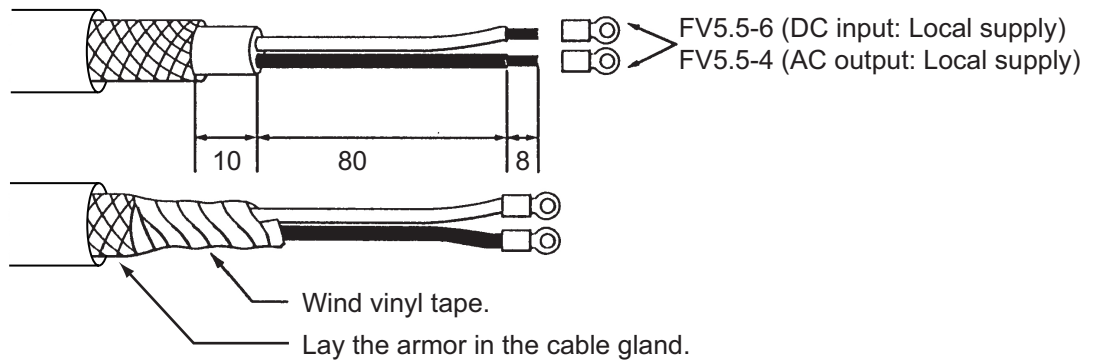

Fabricating JIS cable DPYCY-4, DPYCY-6

2. WIRING

This page is intentionally left blank.

3. ADJUSTMENT

3.1 Measuring TX Output

⚠ WARNING

⚡ ELECTRICAL SHOCK HAZARD
Do not open the equipment unless totally familiar with electrical circuits and service manual.

Only qualified personnel are allowed to work inside the equipment.

1. Set up the control unit as follows:
Range: 400 m, Tx Power: 10 (max.), Vertical Scan: Narrow
Tilt: 0°, Tx Pulselength: 10 (max.)
2. Measure voltage at test point on TRX Boards 10P6862 (14 test points total) in the transceiver unit with an oscilloscope.

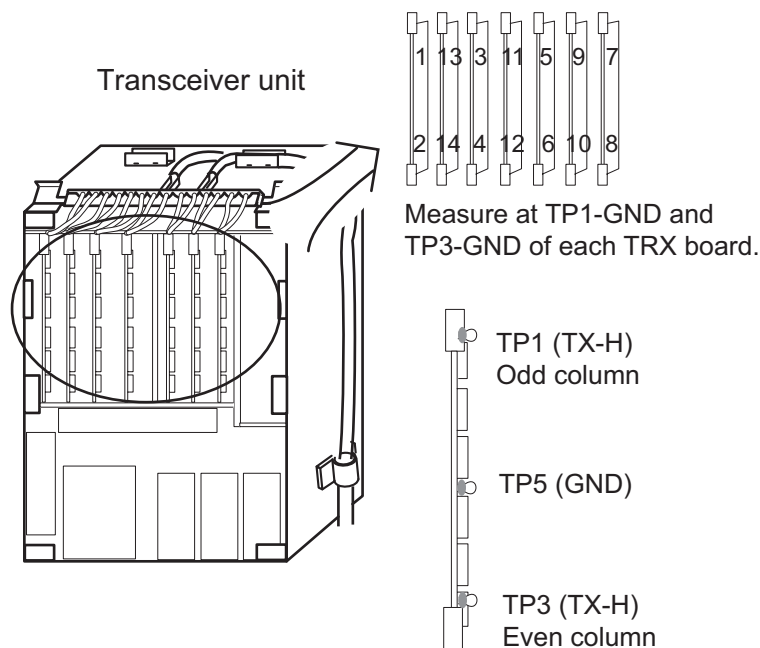

Transceiver unit, upper view

3. ADJUSTMENT

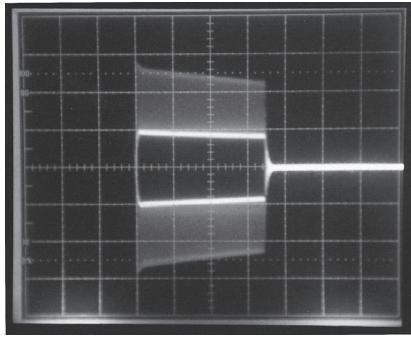

2 μ s/div, 50 V/div

⇒
X axis
exploded
view

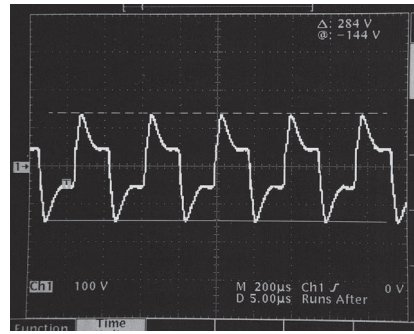

5 μ s/div, 100 V/div

Shorten time axis to 5 μ S/DIV and confirm Vpp.

Typical value of TX output (107 kHz)

Channel	Peak Voltage (Vpp: Ref)	Channel	Peak Voltage (Vpp: Ref)
1	280	5	370
2	220	6	320
13	200	9	370
14	280	10	370
3	320	7	400
4	280	8	370
11	280		
12	320		

Typical value of TX output (85 kHz)

Channel	Peak Voltage (Vpp: Ref)	Channel	Peak Voltage (Vpp: Ref)
1	290	5	290
2	290	6	280
13	270	9	260
14	270	10	300
3	310	7	280
4	322	8	290
11	290		
12	290		

3.2 Heading Alignment

1. Turn on the power. Locate a target (buoy, etc.) in the bow direction and display it on the screen at a close range. The heading alignment is correct if the target in the bow direction is displayed 12 o'clock on the screen. If it is not, go to step 2.

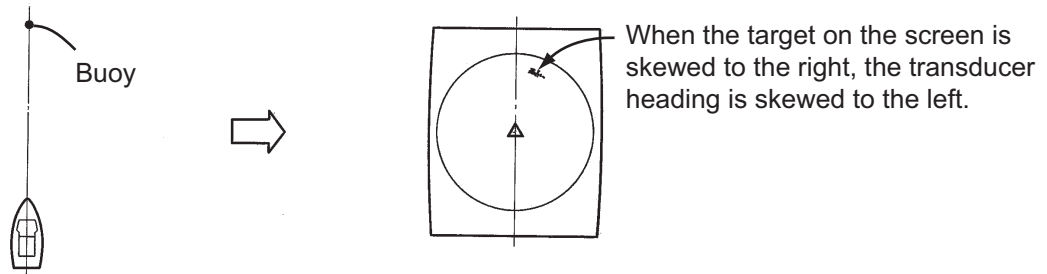

Locating a target to use for aligning heading

2. Read the skewed degree of the target selected at step 1.
3. Press the [MENU] key.
4. Use the [RANGE] control to choose [MENU MODE].
5. Use the [GAIN] control to choose SYSTEM to show the System menu.

** SYSTEM MENU **		(RANGE CTRL: U/D, GAIN CTRL: L/R)	
[MENU MODE]	: SONAR	SOUNDER	MARKS SYSTEM
DIMMER	: 10		
DISP SELECT	: TEMP	CURRENT	
HEADING ADJ	: 0°		
AUTO RETRACT	: OFF	(OFF, 5-16kn)	

System menu

6. Rotate the [RANGE] control to select HEADING ADJ.
7. Rotate the [GAIN] control to set value so a target directly ahead in bow direction is displayed at 12 o'clock.

3.3 Setting for External Equipment

Do the following settings depending on the external equipments connected. Open the System menu referring to the previous page.

** SYSTEM MENU **		(RANGE CTRL: U/D, GAIN CTRL: L/R)			
[MENU MODE]	:	SONAR	SOUNDER	MARKS	SYSTEM
DIMMER	:	10			
DISP SELECT	:	TEMP	CURRENT		
HEADING ADJ	:	0°			
AUTO RETRACT	:	OFF	(OFF, 5-16kn)		
SPEED MESSAGE	:	ON	OFF		
EXT KP SYNC	:	OFF	ON		
AUTO TRAIN SPD	:	LOW	HIGH		
AUTO TILT SPD	:	LOW	HIGH		
UNIT	:	METERS	FEET	FATHOMS	PA/BRA
SHIP'S SPD/BR	:	LOG/GYRO	CURRENT	NAV DATA	GYRO+NAV
LOG PULSE	:	200	400		
PORT1 BAUDRATE	:	19200	9600	4800	2400
PORT1 FORMAT	:	NMEA	CIF		
PORT2 BAUDRATE	:	19200	9600	4800	2400
PORT2 FORMAT	:	NMEA	CIF		
NAV DATA	:	GPS	LC	DR	ALL
COMBI SCALE	:	RIGHT	LEFT		
SUB TEXT INDI	:	OFF	ON		
LANGUAGE	:	ENGLISH	日本語	ESPAÑOL	DANSK
		NEDERLND	FRANÇAIS	ITALIANO	한국어
		NORSK	ไทย	中文	VIET
		မြန်မာ	INDONESIA		
ACTIVATIONCODE	:	EXECUTE			
TEST	:	SINGLE	CONTI	PANEL	COLOR
	:	PATTERN	SIO	ECHO-1	ECHO-2
	:	ECHO-3	ECHO-4		
SET TO DEFAULT	:	EXECUTE			
PRESS [MENU] KEY TO EXIT					

[-----] = Items should be set after the installation.

EXT KP SYNC

Select using or not using the external keying pulse (See “Synchronizing Transmission with Other Equipment” on page 2-15.)

1. Rotate the [RANGE] control to select EXT KP SYNC.
2. Rotate the [GAIN] control to choose OFF or ON.
OFF: Not using the external keying pulse.
ON: Using the external keying pulse.

SHIP'S SPD/BR

Choose the source of speed and course data with which to draw ship's track.

1. Rotate the [RANGE] control to select SHIP'S SPD/BR.
2. Rotate the [GAIN] control to choose item appropriately.
 - LOG/GYRO: Use data from the speed log connected to LOG port as ship's speed, data from gyrocompass connected to GYRO port as ship's course.
 - CURRENT: Use data from the current indicator connected to NMEA1/CIF1 or NMEA2/CIF2 port.
 - NAV DATA: Use data from the equipment (set at [NAV DATA] described on next page) connected to NMEA1/CIF1 or NMEA2/CIF2 port.
 - GYRO+NAV: Use heading data signal from the sensor connected to GYRO port for course, data from the equipment (set at [NAV DATA] described on next page) or current indicator connected to NMEA1/CIF1 or NMEA2/CIF2 port for the ship's speed. When using data from the current indicator (for positioning) for ship's speed, set DIP switch #2-2 in the transceiver unit to ON.

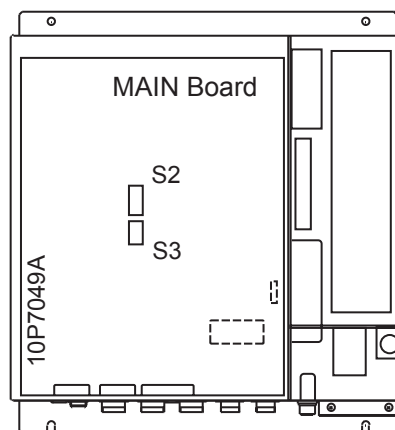

Location of DIP switch S3

LOG PULSE

Choose log pulse/mile specification of speed signal from the LOG port, 200 or 400 pulse/mile.

1. Rotate the [RANGE] control to select LOG PULSE.
2. Rotate the [GAIN] control to choose 200 or 400.

PORT 1 BAUDRATE. PORT 2 BAUDRATE

Set baud rate of equipment connected to NMEA1/CIF1 or NMEA2/CIF2 port, among 2400, 4800, 9600 and 19200 (bps).

1. Rotate the [RANGE] control to select PORT 1 BAUDRATE or PORT 2 BAUDRATE.
2. Rotate the [GAIN] control to choose item among 2400,4800, 9600 and 19200.

3. ADJUSTMENT

PORT 1 FORMAT, PORT 2 FORMAT

Set data format of equipment connected to NMEA/CIF 1 port or NMEA/CIF 2 port.

1. Rotate the [RANGE] control to select PORT 1 FORMAT or PORT 2 FORMAT.
2. Rotate the [GAIN] control to choose NMEA or CIF depending on the equipment connected.

NAV DATA

Choose source of nav data among GPS, LC (Loran C), DR (Dead Reckoning) or ALL. "ALL" automatically chooses source in the order of GPS, Loran C and dead reckoning. (Priority: GPS>LC>DR)

1. Rotate the [RANGE] control to select NAV DATA.
2. Rotate the [GAIN] control to choose item among GPS, LC, DR or ALL.
Select "DR" when using the equipment connected to GYRO port and LOG port

3.4 Smoothing the GPS Data

If position data from the GPS navigator is not smooth, set DIP switch S2 in the processor unit as below to smooth it.

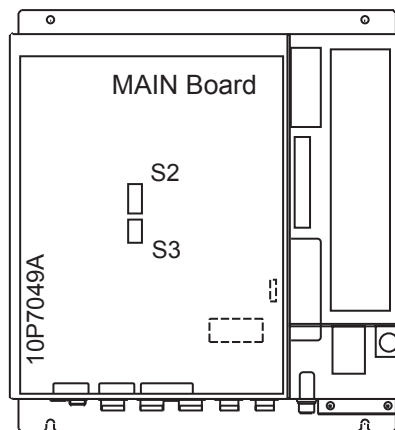

#3	#4	GPS course change
ON	ON	10°
ON	OFF	20°
OFF	ON	45°
OFF	OFF	90° (default setting)

#5	#	GPS ship's speed average
ON	ON	2.0 kn
ON	OFF	1.5 kn
OFF	ON	1.0 kn
OFF	OFF	0.5 kn (default setting)

#7	Smoothing function
ON	Yes
OFF	No (default setting)

When all switches are ON, GPS positioning data smoothed so that the course change is within 10° when own ship's speed is 2.0 kn or less.

3.5 NMEA Version Setting

Change the jumper block setting in the processor unit according to NMEA version to output.

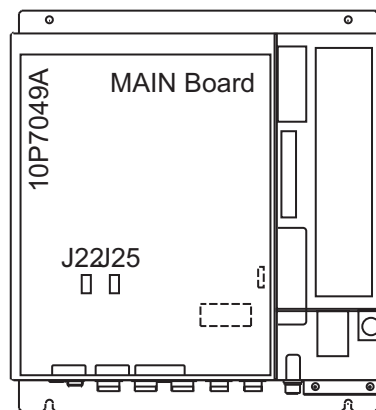

Location of jumper block J22 and J25

Jumper	NMEA Ver1.5	CIF or NMEA Ver2.0	Port
J22	1-2 (Default setting)	2-3	NMEA1/CIF1
J25	1-2 (Default setting)	2-3	NMEA2/CIF2

3.6 Adjusting Echo Sounder Video

When using the E/S interface to connect an echo sounder, adjust the video signal with the potentiometer R142 on the MAIN Board in the processor unit.

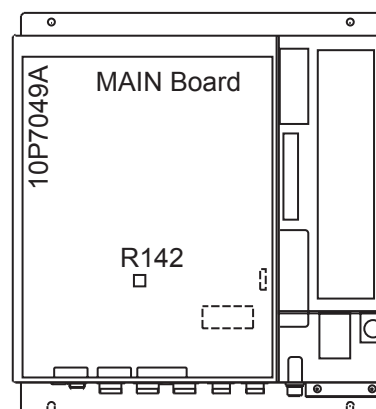

Location of volume register R142

1. Rotate R142 so that the line on it locates at the center position
2. Set the SOUNDER MENU as below to appear noises on the screen.
GAIN: 10, CLUTTER: 0
3. On the SOUNDER MENU, set E/S INT REJECT to ON.
4. Set GAIN to 0.
5. Adjust R142 so that noises disappear.
6. Return the GAIN setting to 10.
7. After setting GAIN to 10, set CLUTTER to 10.
8. Adjust R142 so that noises disappear.

3.7 Sea Trial

Cruising noise check

Check and record the cruising noise level displayed on the screen. Do this with the transceiver turned off and the ship anchored, and also with the ship running at the speed normally used while the sonar is in use.

Ship anchored

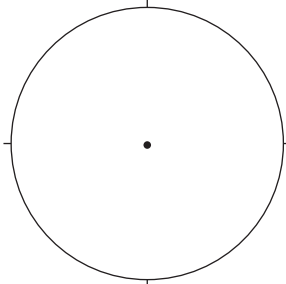

NL	_____	ENG RPM	_____
RANGE	800 m	SPEED	0 kn
GAIN	5.0	SEA CONDITION	_____
TVG	N <input type="text" value="5"/> F <input type="text" value="5"/>		
TILT	0°		
DEPTH	_____		_____

Ship at cruising speed

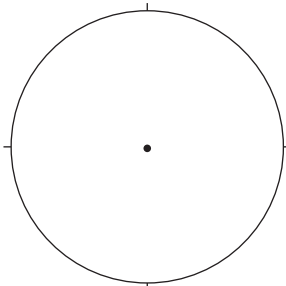

NL	_____	ENG RPM	_____
RANGE	800 m	SPEED	_____
GAIN	5.0	SEA CONDITION	_____
TVG	N <input type="text" value="5"/> F <input type="text" value="5"/>		
TILT	0°		
DEPTH	_____		_____

Recording optimum control settings

Record the suitable settings of controls and switches, and take a photograph of the sonar picture as reference for later service.

PHOTOGRAPH	RANGE	<input type="text"/>
	TILT	<input type="text"/>
	TVG	N <input type="text"/> F <input type="text"/>
	GAIN	<input type="text"/>
	OUTPUT	<input type="text"/>
	TX PULSELENGTH	<input type="text"/>
	NOISE LIMITER	<input type="text"/>
	AGC	<input type="text"/>
	VP	<input type="text"/>
	INTERFERENCE REJ	<input type="text"/>

APPX. 1 JIS CABLE GUIDE

Cables listed in the manual are usually shown as Japanese Industrial Standard (JIS). Use the following guide to locate an equivalent cable locally.

JIS cable names may have up to 6 alphabetical characters, followed by a dash and a numerical value (example: DPYC-2.5).

For core types D and T, the numerical designation indicates the *cross-sectional Area (mm²)* of the core wire(s) in the cable.

For core types M and TT, the numerical designation indicates the *number of core wires* in the cable.

1. Core Type

D: Double core power line

T: Triple core power line

M: Multi core

TT: Twisted pair communications
(1Q=quad cable)

2. Insulation Type

P: Ethylene Propylene Rubber

3. Sheath Type

Y: PVC (Vinyl)

4. Armor Type

C: Steel

5. Sheath Type

Y: Anticorrosive vinyl sheath

6. Shielding Type

SLA: All cores in one shield, plastic tape w/aluminum tape

-SLA: Individually shielded cores, plastic tape w/aluminum tape



DPYC



TPYC

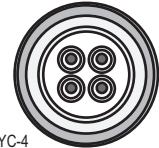

MPYC-4

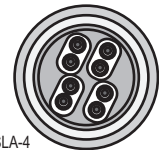

TTYCSLA-4

EX: ¹ ³ ⁴ ⁵ ⁶
TTYCYSLA - 4
 Designation type | # of twisted pairs

¹ ² ³ ⁴
MPYC - 4
 Designation type | # of cores

The following reference table lists gives the measurements of JIS cables commonly used with Furuno products:

Type	Core Area	Core Diameter	Cable Diameter	Type	Core Area	Core Diameter	Cable Diameter
DPYC-1.5	1.5mm ²	1.56mm	11.7mm	TTYCSLA-1	0.75mm ²	1.11mm	9.4mm
DPYC-2.5	2.5mm ²	2.01mm	12.8mm	TTYCSLA-1T	0.75mm ²	1.11mm	10.1mm
DPYC-4	4.0mm ²	2.55mm	13.9mm	TTYCSLA-1Q	0.75mm ²	1.11mm	10.8mm
DPYC-6	6.0mm ²	3.12mm	15.2mm	TTYCSLA-4	0.75mm ²	1.11mm	15.7mm
DPYC-10	10.0mm ²	4.05mm	17.1mm	TTYCY-1	0.75mm ²	1.11mm	11.0mm
DPYCY-1.5	1.5mm ²	1.56mm	13.7mm	TTYCY-1T	0.75mm ²	1.11mm	11.7mm
DPYCY-2.5	2.5mm ²	2.01mm	14.8mm	TTYCY-1Q	0.75mm ²	1.11mm	12.6mm
DPYCY-4	4.0mm ²	2.55mm	15.9mm	TTYCY-4	0.75mm ²	1.11mm	17.7mm
MPYC-2	1.0mm ²	1.29mm	10.0mm	TTYCY-4SLA	0.75mm ²	1.11mm	19.5mm
MPYC-4	1.0mm ²	1.29mm	11.2mm	TTYCYSLA-1	0.75mm ²	1.11mm	11.2mm
MPYC-7	1.0mm ²	1.29mm	13.2mm	TTYCYSLA-4	0.75mm ²	1.11mm	17.9mm
MPYC-12	1.0mm ²	1.29mm	16.8mm	TTPYCSLA-1	0.75mm ²	1.11mm	9.2mm
TPYC-1.5	1.5mm ²	1.56mm	12.5mm	TTPYCSLA-1T	0.75mm ²	1.11mm	9.8mm
TPYC-2.5	2.5mm ²	2.01mm	13.5mm	TTPYCSLA-1Q	0.75mm ²	1.11mm	10.5mm
TPYC-4	4.0mm ²	2.55mm	14.7mm	TTPYCSLA-4	0.75mm ²	1.11mm	15.3mm
TPYCY-1.5	1.5mm ²	1.56mm	14.5mm				
TPYCY-2.5	2.5mm ²	2.01mm	15.5mm				
TPYCY-4	4.0mm ²	2.55mm	16.9mm				

APPX. 2 PROCEDURE FOR RETRO-FITTING

When retrofitting the CH series with the CSH-8L MARK-2, it is not necessary to change the retraction tank. However, the hull unit must be chosen according to retraction tank length. Refer to the table below to choose hull unit. This must also be done with the 1800 mm or 3500 mm retraction tank.

Tank length (L) mm	Hull unit type	Remarks
600 < L ≤ 750	CSH-8040-A-107-N-13	Transducer cable: 4200 mm, Main shaft: 1300 mm
	CSH-8040-A -85-N-13	
750 < L ≤ 1000	CSH-8040-A -107-N-15	Transducer cable: 4200 mm, Main shaft: 1550 mm
	CSH-8040-A -85-N-15	
1000 < L ≤ 1800	CSH-8040-A -107-N-23	Transducer cable: 4900 mm, Main shaft: 2350 mm
	CSH-8040-A -85-N-23	
1800 < L ≤ 3500	CSH-8040-A -107-N-40	Transducer cable: 6600 mm, Main shaft: 4065 mm
	CSH-8040-A -85-Nx40	

Note: The hull unit CSH-8041-A (400 mm transducer travel) cannot be used.

Installation when retraction tank is more than 750 mm long

- Calculate the necessary length of the main shaft.
 - Main shaft length = Tank length + 565 mm (see page AP-5).
 - If there is a sufficient space above the hull unit, it is not necessary to cut the main shaft; the main shaft is installed with its top portion protruded beyond the top of the hull unit.
 - If the cut length of the main shaft is less than 50 mm, use it without cutting the shaft. Waterproofing attachment is not necessary. Note, however, that protrusion length of the transducer is reduced.
- Cut the main shaft to the necessary length.
 - It is recommended to use a machine lathe to shorten the shaft.
 - Chamfer the top of the main shaft as shown below. (For chamfering with a file use a fine file and finish the surface as smooth as possible.)
 - When clamping the shaft with a clamp, be careful not to damage the shaft surface.
 - When a metal saw is used to shorten the shaft, finish the top of the shaft so that it is level within 3 mm.

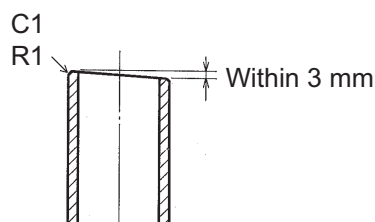

3. Temporarily install the waterproofing attachment on the top of the main shaft and drill holes for socket-set screws.

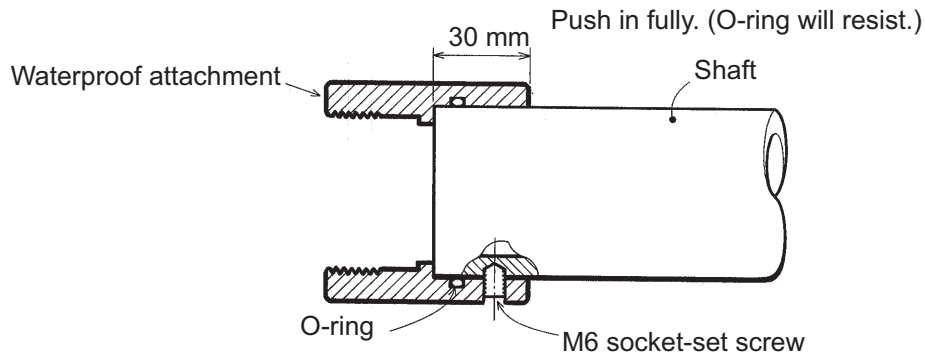

- a) Mark drilling point on the shaft surface by tightening M6 socket-set screws (2 pcs.)
- b) Remove the waterproofing attachment.
- c) Drill holes less than 2 mm in depth. The drill bit should be stainless steel, $\phi 5$, 120° tip. Do not drill holes through the shaft. Use a low rpm drill, and use cutting oil.

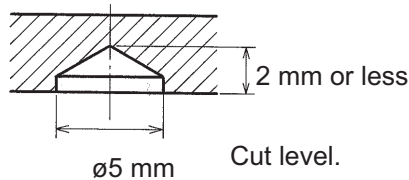

4. Remove the sheath of the transducer cable and wrap the sheath end with vinyl tape.

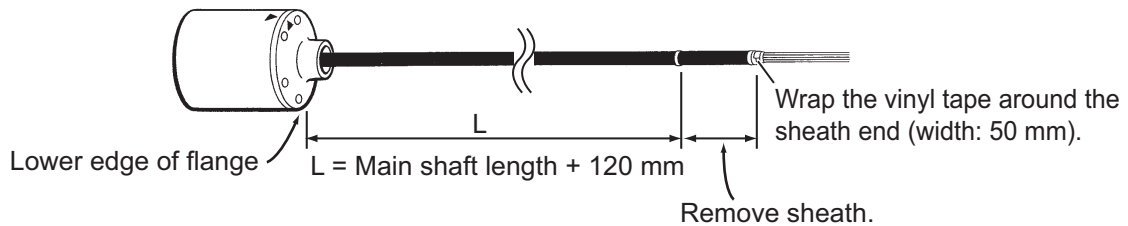

5. Pass the main shaft through the main body flange and assemble the hull unit. Refer to Chapter 1 for the assembling procedure.
6. Clean the top of the main shaft with alcohol, install the waterproofing attachment and apply Loctite (supplied) to the lock-screw.

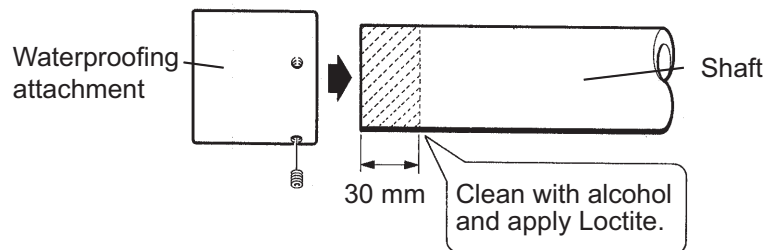

- Tighten the M6 socket-set screws with a torque of 3.92 to 4.9 N•m.
- Refer to page 1-6 for installing the waterproofing attachment.

APPX. 2 PROCEDURE FOR RETROFITTING

7. Assemble the hull unit, taking the following points into account:

- 1) The shaft retainer should be in contact with the waterproofing attachment.
- 2) The fastening band should not be used on the main shaft when it is fitted with the waterproofing attachment.
- 3) When the main shaft is installed without cutting position the shaft retainer as below.

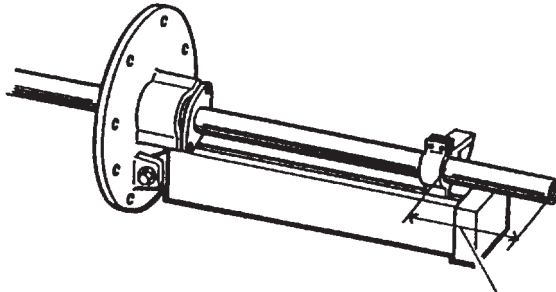

As shown on page AP-5,
length is cut length + 45 mm

Installation when retraction tank is 600 to 750 mm long

1. Follow steps 1 through 5 in the previous procedure.
2. Set the transducer travel to 450 mm by changing the position of the upper limit switch.

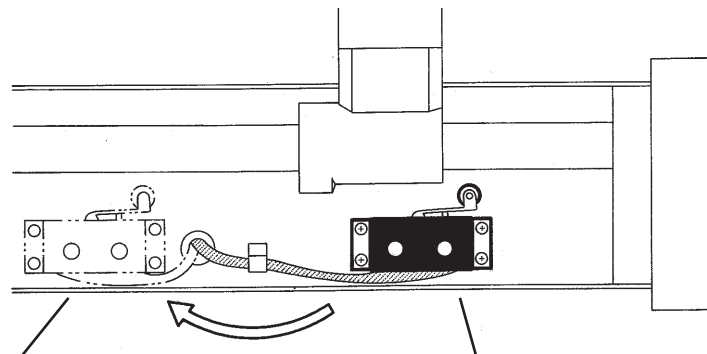

Move the upper limit switch
to modify to 450 mm travel.

Upper limit switch.

3. Assemble the hull unit, taking the following points into account. Refer to Chapter 1 for assembly instruction.

Note 1: The tank guide should be installed at the position 162 mm above the top of the transducer flange.

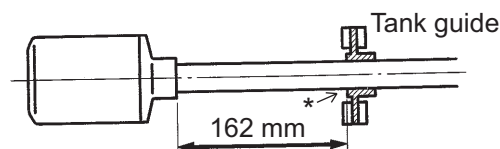

*: Measure between the top of the transducer flange and
the inner edge of the tank guide.

Note 2: The shaft retainer should be in contact with the waterproofing attachment.

Relation between retraction tank length and main shaft length

Main shaft		945		1300		1550		2350		4065	
Shaft length cut length		Shaft L(m)	Cut L(m)	Shaft L(m)	Cut L(m)	Shaft L(m)	Cut L(m)	Shaft L(m)	Cut L(m)	Shaft L(m)	Cut L(m)
Hull unit	Tank length										
CSH-8041-A 400 stroke	550	945	0								
	600			1015	285						
CSH-8040-A 600 stroke converted to 450 stroke	650			1065	235						
	700			1150	185						
	750			1300	0						
CSH-8040-A 600 stroke	800					1365	185				
	850					1415	135				
	900					1465	85				
	950					1515	35				
	1000					1550	0				
	1100							1665	685		
	1200							1765	585		
	1300							1865	485		
	1400							1965	385		
	1500							2065	285		
	1600							2165	185		
	1700							2265	85		
	1800							2350	0		
	1900									2465	1600
	2000									2565	1500
	2100									2665	1400
	2200									2765	1300
	2300									2865	1200
	2400									2965	1100
	2500									3065	1000
2600									3165	900	
2700									3265	800	
2800									3365	700	
2900									3465	600	
3000									3565	500	
3100									3665	400	
3200									3765	300	
3300									3865	200	
3400									3965	100	
3500									4065	0	

Note: When there is enough space above the hull unit, it is not necessary to cut the shaft. (Fasten the shaft with the shaft retainer at the position of “cut length + 45 mm” from the upper edge of the shaft.

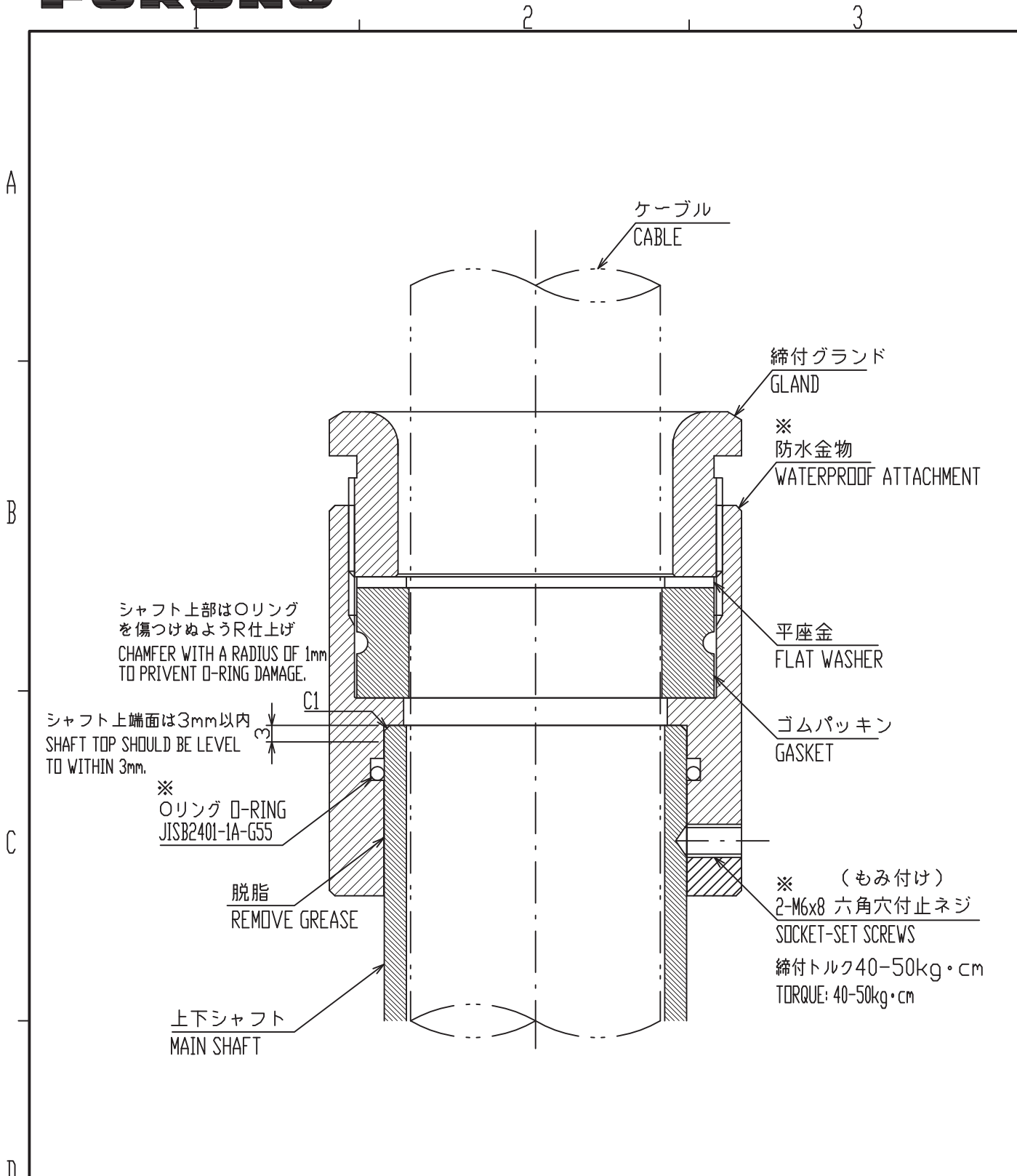

注記

1) ※: 防水金物セットに含む (オプション)。

NOTE

1. ※: SUPPLIED AS WATERPROOF ATTACHMENT (OPTION).

DRAWN	Dec. 25 '02	T.YAMASAKI	TITLE
CHECKED	Dec. 25 '02	Y.KIMURA	名称
APPROVED			上下シャフト上端 (防水金物)
SCALE	1/1	MASS ±10% kg	装備要領
DWGNo.	C1273-Y01- B		NAME
			CONSTRUCTION OF MAIN SHAFT TOP INSTALLATION PROCEDURE

APPX. 3 DIP SWITCH SELECTION FOR THAI VERSION SOFTWARE (CSH-8L MARK-2-85 ONLY)

Thai version software: Made for Thai customers. The display color, color curve and range settings will be different from the standard version.

Item	Board		How to change the software
Display color	Main board of control unit.	10P7049A	Dip Switch selection: S2-1→ON: Thai version OFF: Standard version
Color curve, range settings	DIG board of transceiver unit	10P7071	Dip Switch selection: S1-7→ON: Thai version OFF: Standard version

This page is intentionally left blank.

CODE NO.	006-910-940-00	10CS-X-9403-5
TYPE	CP10-05201	1/1

工事材料表 INSTALLATION MATERIALS		数量 Q'TY		用途/備考 REMARKS	
番号 NO.	名称 NAME	略図 OUTLINE	型名/規格 DESCRIPTIONS	数量 Q'TY	用途/備考 REMARKS
1	コネクタ (8016) CONNECTOR (8016)		008016-008-313761HF CODE NO. 000-159-017-11	1	
2	イソラチューブ A INSULATION TUBE		3.0X0.3 TEL #50CM* CODE NO. 000-162-841-10	2	
3	コンタクトピン (8017) CONTACT PIN (8017)		60-8017-0313-00339F+ 00-8017-0313-00339F+ CODE NO. 000-159-417-11 000-159-417-10	40	
4	ビニル線 VINYL WIRE		K1V 2.0SQ 7# #2M* CODE NO. 000-554-516-10	1	
5	コネクタ (SR0N) CONNECTOR (SR0N)		SR0N6A13-3P CODE NO. 000-166-722-10	1	
6	コネクタ (SR0N) CONNECTOR (SR0N)		SR0N6A13-5P CODE NO. 000-166-726-10	1	
7	コネクタ (SR0N) CONNECTOR (SR0N)		SR0N6A16-10P CODE NO. 000-166-728-10	2	
8	コネクタ (SR0N) CONNECTOR (SR0N)		SR0N6A16-7P CODE NO. 000-166-730-10	1	

型式/コード番号が異なる場合、下段より上段に代わる通達期品であり、どちらが入っています。なお、品質は変わりません。
TWO TYPES AND CODES MAY BE LISTED FOR AN ITEM. THE LOWER PRODUCT MAY BE SHIPPED IN PLACE OF THE UPPER PRODUCT.
QUALITY IS THE SAME.
(略図の寸法は、参考値です。DIMENSIONS IN DRAWING FOR REFERENCE ONLY.)

CODE NO.	006-911-000-00	10CS-X-9405-3
TYPE	CP10-05501	1/1

工事材料表 INSTALLATION MATERIALS		数量 Q'TY		用途/備考 REMARKS	
番号 NO.	名称 NAME	略図 OUTLINE	型名/規格 DESCRIPTIONS	数量 Q'TY	用途/備考 REMARKS
1	コネクタ CABLE TIE		CY-100N CODE NO. 000-162-167-10	30	
2	コネクタ CABLE TIE		CY-200N CODE NO. 000-162-183-10	20	
3	コネクタ CABLE TIE		CY-300N CODE NO. 000-162-165-10	10	
4	圧着端子 CRIMP-ON LUG		FV5-5-4(LF) YEL CODE NO. 000-166-744-10	2	
5	7-ス板 COPPER STRAP		MEA-1004-0 RHMS CODE NO. 500-310-040-10	1	

型式/コード番号が異なる場合、下段より上段に代わる通達期品であり、どちらが入っています。なお、品質は変わりません。
TWO TYPES AND CODES MAY BE LISTED FOR AN ITEM. THE LOWER PRODUCT MAY BE SHIPPED IN PLACE OF THE UPPER PRODUCT.
QUALITY IS THE SAME.
(略図の寸法は、参考値です。DIMENSIONS IN DRAWING FOR REFERENCE ONLY.)

FURUNO

CODE NO. 10CS-X-9406-1
TYPE FPI0-02701

工事材料表 INSTALLATION MATERIALS		CSH-8L		10CS-X-9406-1		1/1	
番号 NO.	名称 NAME	略図 OUTLINE	型名/規格 DESCRIPTIONS	数量 QTY	用途/備考 REMARKS		
1	信号ケーブル組品 SIGNAL CABLE ASSY.		S10-6-15 (38P) *15M* CODE NO. 006-976-530-00	1	制御/送受信装置用 FOR CONTROL/TRANSMITTER UNIT *選択*TO BE SELECT		
2	信号ケーブル組品 SIGNAL CABLE ASSY.		S10-6-30 (38P) *30M* CODE NO. 006-976-530-00	1	制御/送受信装置用 FOR CONTROL/TRANSMITTER UNIT *選択*TO BE SELECT		
3	信号ケーブル組品 SIGNAL CABLE ASSY.		S10-6-50 (38P) *50M* CODE NO. 006-976-600-00	1	制御/送受信装置用 FOR CONTROL/TRANSMITTER UNIT *選択*TO BE SELECT		
4	信号ケーブル組品 SIGNAL CABLE ASSY.		S10-15-10 CODE NO. 006-800-520-00	1	送受信/上下装置用 FOR TRANSMITTER UNIT/HULL UNIT *選択*TO BE SELECT		
5	信号ケーブル組品 SIGNAL CABLE ASSY.		S10-15-5 CODE NO. 006-800-510-00	1	送受信/上下装置用 FOR TRANSMITTER UNIT/HULL UNIT *選択*TO BE SELECT		
6	ケーブル組品 CABLE ASSY.		300X-2F-6C *10M* CODE NO. 001-077-220-10	1	表示部/制御部 FOR MONITOR/CONTROL UNIT *選択*TO BE SELECT		
7	ケーブル組品 CABLE ASSY.		300X-2F-6C *5M* CODE NO. 001-077-220-10	1	表示部/制御部 FOR MONITOR/CONTROL UNIT *選択*TO BE SELECT		

型式/コード番号が2段の場合、下段より上段に代わる過渡期品であり、どちらかが入っています。なお、品質は変わりません。
TWO TYPES AND CODES MAY BE LISTED FOR AN ITEM. THE LOWER PRODUCT MAY BE SHIPPED IN PLACE OF THE UPPER PRODUCT.
QUALITY IS THE SAME.
(略図の寸法は、参考値です。 DIMENSIONS IN DRAWING FOR REFERENCE ONLY.)

FURUNO ELECTRIC CO., LTD.

C1320-M01-B

FURUNO

CODE NO. 10CS-X-9501-5
TYPE FPI0-02701

付属品表 ACCESSORIES				10CS-X-9501-5		1/1	
番号 NO.	名称 NAME	略図 OUTLINE	型名/規格 DESCRIPTIONS	数量 QTY	用途/備考 REMARKS		
1	KB固定器具 KB MOUNTING PLATE		D-076-2221-0 RHIS CODE NO. 100-302-210-10	1			
2	平垫金 FLAT WASHER		M4 C2680R CODE NO. 000-166-235-10	2			
3	六角ナット HEX. NUT		M4 C3604B CODE NO. 000-166-237-10	2			
4	平垫金 SPRING WASHER		M4 C5191W CODE NO. 000-166-238-10	2			
5	オвалヘッドネジ OVAL HEAD SCREW		M4X12 C2700W MBN12 CODE NO. 000-163-309-10	2			
6	六角ボルト HEX BOLT		M6X12 SUS304 CODE NO. 000-162-574-10	4			
7	ゴム足 RUBBER FEET		S-5-5003 加 CODE NO. 000-165-669-10	4			

型式/コード番号が2段の場合、下段より上段に代わる過渡期品であり、どちらかが入っています。なお、品質は変わりません。
TWO TYPES AND CODES MAY BE LISTED FOR AN ITEM. THE LOWER PRODUCT MAY BE SHIPPED IN PLACE OF THE UPPER PRODUCT.
QUALITY IS THE SAME.
(略図の寸法は、参考値です。 DIMENSIONS IN DRAWING FOR REFERENCE ONLY.)

FURUNO ELECTRIC CO., LTD.

C1319-F01-F

標準装備 STANDARD INSTALLATION

防水室内装備 WATERTIGHT ROOM INSTALLATION

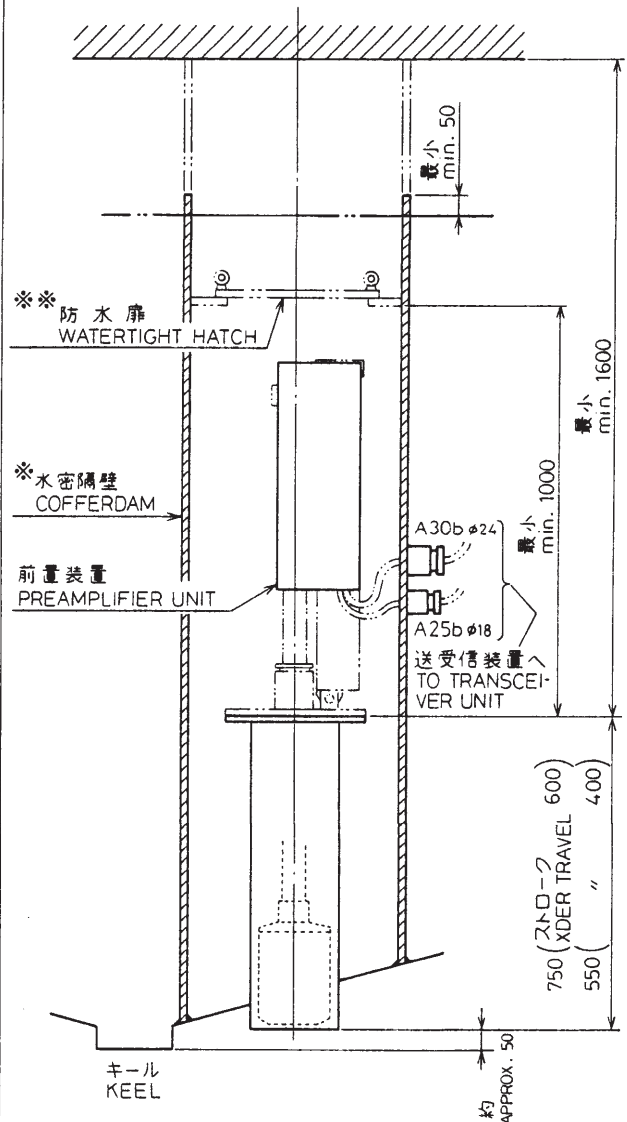
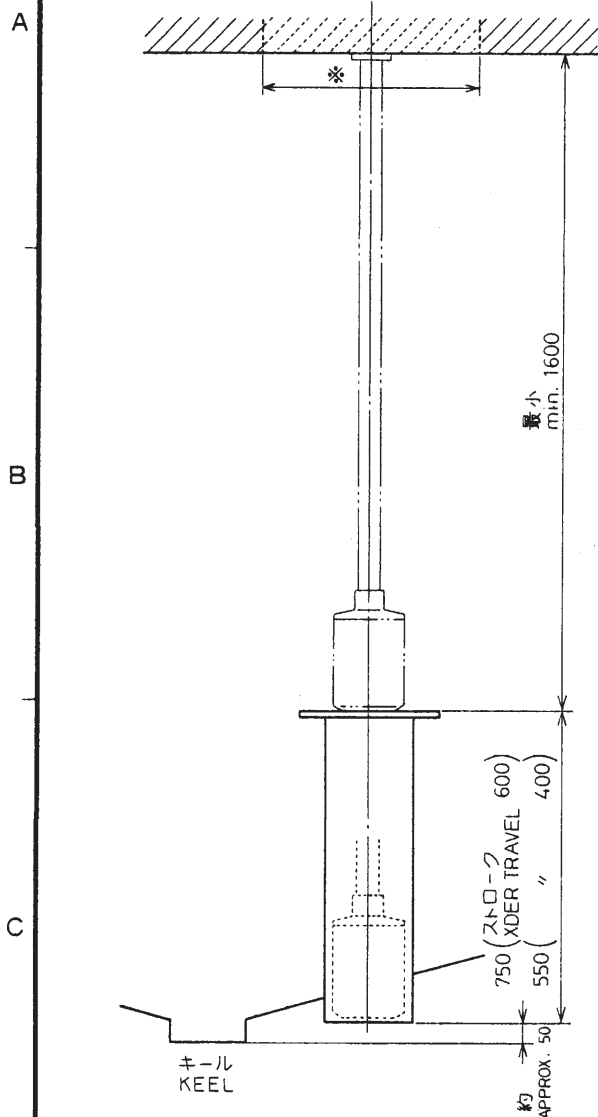

※ 上下装置上部に1600mmのサービス空間を取れない場合は、天井に“300×300”の穴をあけておくこと。

※ IF OVERHEAD CLEARANCE OF 1600MM IS NOT ALLOWED, MAKE A HOLE OF 300×300MM ON CEILING FOR EASE OF INSTALLATION AND FUTURE SERVICE.

1. 水密隔壁は船級協会規則を参照し、造船所で作成下さい。その際サービススペースも考慮して下さい。
2. ※※水密隔壁の上限を吃水線の上までとれない場合には上下装置取り外しの為、防水扉を設けること。
1. CONSTRUCT THE COFFERDAM IN ACCORDANCE WITH CONCERNED REGULATION. ALSO ALLOW ENOUGH MAINTENANCE SPACE.
2. ※※ PROVIDE A WATER TIGHT HATCH FOR FUTURE MAINTENANCE IF A COFFERDAM IS NOT HIGH ABOVE WATER LEVEL.

D

CSH-5		品番 ITEM	品名 NAME		材質 MATERIAL	数量 Q'TY	図番 DWG.NO.	摘要 REMARKS
承認 APPROVED	••	三角法 THIRD ANGLE PROJECTION		名称 TITLE	格納タンクの装備例 RETRACTION TANK INSTALLATION METHOD			
検図 CHECKED	••	尺度 SCALE	✕					
製図 DRAWN	Nob. 13.89 M. USUDA	重量 WEIGHT	kg		図番 DWG.NO.	C1273-Y02-A		

表 1 TABLE 1

寸法区分(mm) DIMENSION	公差(mm) TOLERANCE
0 < L ≤ 50	±1.5
50 < L ≤ 100	±2.5
100 < L ≤ 500	±3
500 < L ≤ 1000	±4
1000 < L ≤ 2000	±5
2000 < L ≤ 4000	±7

A

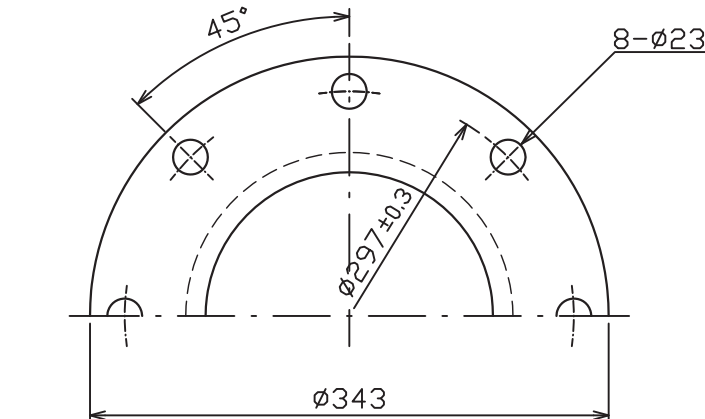

B

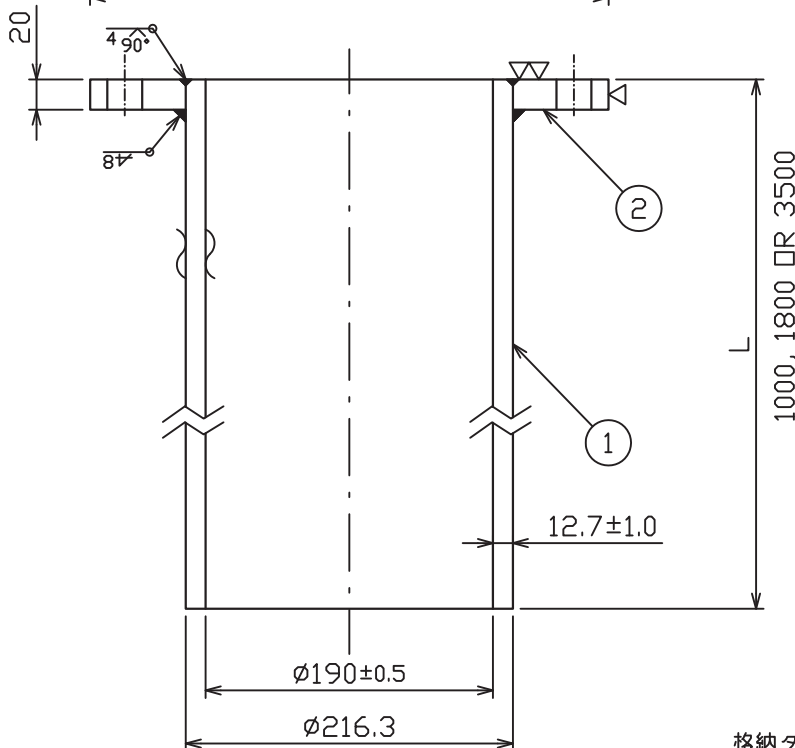

C

注記

- 1) 指定なき寸法公差は表 1 による。
- 2) フランジ面は塗装しないこと。
- 3) タンク側面はエピコンジクリッチプライマ（中国塗料製）を塗布すること。
- 4) タンク内面はビニル防汚塗料を二重に塗布すること。

格納タンクの長さ : Lt
 LENGTH OF RETRACTION TANK: Lt
 Lt = mm

NOTE

1. TABLE 1 INDICATES TOLERANCE OF DIMENSIONS WHICH IS NOT SPECIFIED.
2. DO NOT PAINT ON SURFACE OF FLANGE.
3. APPLY ZINC RICH PRIMER ON OUTSIDE OF TANK.
4. APPLY VINYL ANTI-FOULING PAINT TWICE ON INSIDE OF TANK.

長さ L (mm) LENGTH (mm)	質量(kg±10%) MASS
1000	73
1800	123
3500	231

D

2	フランジ FLANGE	SS41P	1	JIS G3101	ROLLED STEEL FOR GENERAL STRUCTURE
1	本体 BODY	STPG-38-E-C	1	200A, 8" SCHEDULE 80	
品番 ITEM	品名 NAME	材質 MATERIAL	数量 QTY	図番 DWG. No.	摘要 REMARKS

DRAWN	7/May/2013 T.YAMASAKI	TITLE	06-007-1570
CHECKED	7/May/2013 H.MAKI	名称	格納タンク（鋼製）
APPROVED	8/May/2013 H.MAKI		外寸図
SCALE	1/5 MASS 表2参照 SEE TABLE 2	NAME	RETRACTION TANK (STEEL HULL)
DWG. No.	C1229-006-H	REF. No.	06-007-1570-2
		OUTLINE DRAWING	



表1 TABLE 1

寸法区分(mm) DIMENSIONS	公差(mm) TOLERANCE
0 < L ≤ 50	±1.5
50 < L ≤ 100	±2.5
100 < L ≤ 500	±3
500 < L ≤ 1000	±4

表2 TABLE 2

タンク長(L) (mm) TANK LENGTH	質量 (kg±10%) MASS	タンク型式 TANK TYPE
1000	12	06-021-4024
1800	18	06-007-1573

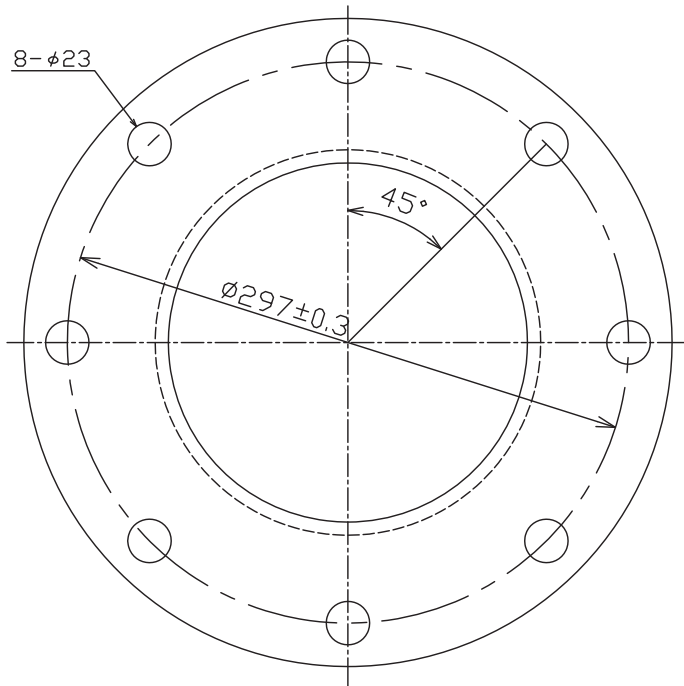
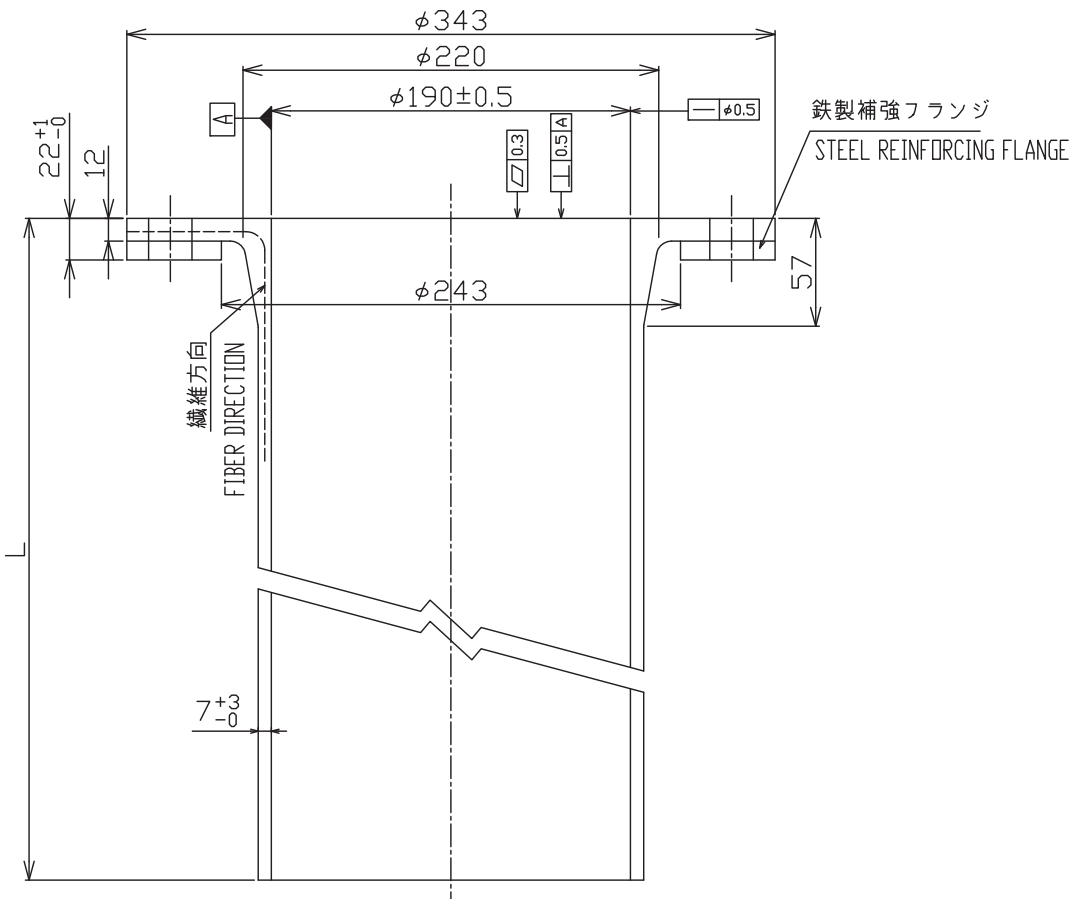

注記

1) 指定外の寸法公差は表1による。

NOTE

1. TABLE 1 INDICATES TOLERANCE OF DIMENSIONS WHICH IS NOT SPECIFIED.

DRAWN 13/Dec/2018 T. YAMASAKI		TITLE 06-021-4024/06-007-1573
CHECKED 13/Dec/2018 H. MAKI	CH-37(BB), etc. CH-500/600 CH-250/300	名称 FRP格納タンク
APPROVED 13/Dec/2018 H. MAKI		外寸図
SCALE 1 / 4	MASS 表2参照 SEE TABLE 2	NAME RETRACTION TANK (FOR FRP HULL)
DWG. No. C1315-G14- D	REF. No. 06-021-4024-0	OUTLINE DRAWING

① キール上 (突出) ON KEEL (PROJECTED)

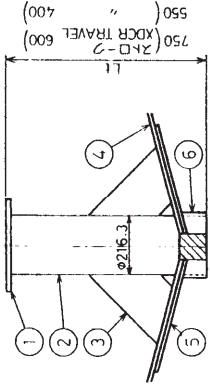

② キール横 (突出) OFF KEEL (PROJECTED)

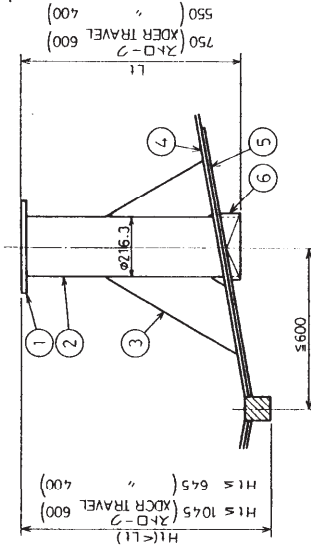

③ キール横 (非突出) OFF KEEL (NOT PROJECTED)

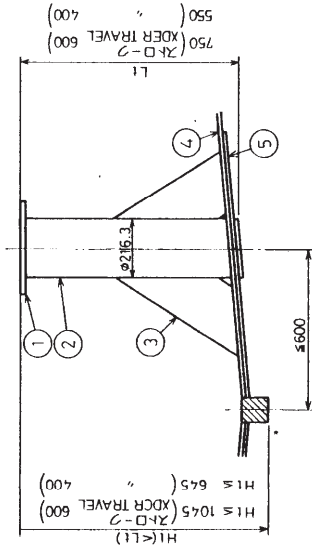

④ 整流覆 FAIRING PLATE

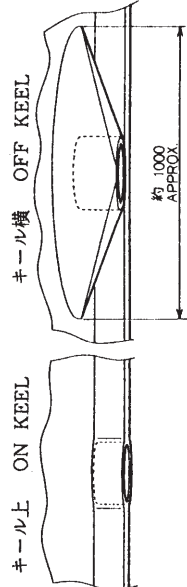

INSTALLATION METHOD OF RETRACTION TANK

- Cut out $\phi 217$ hole on hull and inner hull plate.
- Install tank to hull plate with fillet welding taking the following points into account.
 - Flange face is horizontal at normal Ship's trim.
 - Allow height "Ht" of flange face from keel bottom as mentioned in the drawings, otherwise transducer beam is blocked by the keel when transducer is fully lowered.
 - Tank's length "Lt" should be less than "Ht", otherwise the tank is protruded below keel level. The tank should be cut to the specified length so that the transducer can be fully protruded. (The tank is supplied with 1000 mm long as standard.)
- Fit doubling plate ⑥ of outer dia. $\phi 1000$ mm around the tank on hull plate. Fit fairing plate ④ referring to the drawing ④ for installation method ④ and ⑤. Use same material and thickness of doubling and fairing plate as hull plate.
- Provide cofferdam around the tank in order to isolate the tank from the oil tank.
- Install 4 pcs. of reinforcement plates between the tank and the hull plate.
- Allow clearance of more than 100mm below the flange face for easy bolting. Lower the inner hull plate as shown in the drawing ⑥ if the specified clearance is not secured.

装 備 手 順

- 船底板及び二重船底板に $\phi 217$ の穴を開ける。
- 次の点に注意して、格納タンクを船底板に連続スミ肉溶接する。
 - タンクのフランジ面が、標準走行時に水平になる事。
 - 送受波器を突出させた時に送受信ビームがキールで遮られないように、フランジ面のキールよりの高さ "Ht" を図示の範囲内にする事。
 - タンク下端がキールより下に出ないように、タンクの長さ "Lt" は "Ht" より短くする。且つ、送受波器がタンク下端より出ないように図示の範囲内にする。(標準支給長 1000mm)
- 格納タンクの周囲に外径 $\phi 1000$ 以上のダブルリング⑥を取り付ける。又、突出装構(④、⑤)の場合には、整流覆④(D図)を取り付ける。ダブルリングと整流覆には、船底板と同じ材質、肉厚のものを使用する事。
- タンク周囲に油槽がある場合には、隔壁⑤をめぐらせコfferダム④を設ける事。
- タンク周囲4ヶ所に補強板⑤を溶接する。
- 上下装置本体を格納タンクにボルト締めするのに必要なスペースとして、フランジ面の位置が二重船底板より100mm以上離す。二重船底が高い船には⑥図の方法で二重船底板を下げ、スペースを確保する事。

品番 ITEM	品名 NAME	材 質 MATERIAL	数 量 Q.TY	図 番 DWG.NO.	備 考 REMARKS
6	整流覆 FAIRING PLATE				
5	ダブルリング DOUBLING				
4	船底板 HULL PLATE				
3	補強板 REINFORCEMENT PLATE				
2	格納タンク RETRACTION TANK				
1	タンクフランジ TANK FLANGE				
品名 NAME TYPE 名称 名称 格納タンク (鋼船) 格納タンク (鋼船) 送受波器装構図 送受波器装構図 名称 名称 RETRACTION TANK (STEEL HULL) RETRACTION TANK (STEEL HULL)					

DRW. NO.	C1273-101-C
CHECKED	Apr. 25 '97
APPROVED	Apr. 25 '97
SCALE	1/1
APPLICABLE TO:	MASS
DWG. NO.	KG

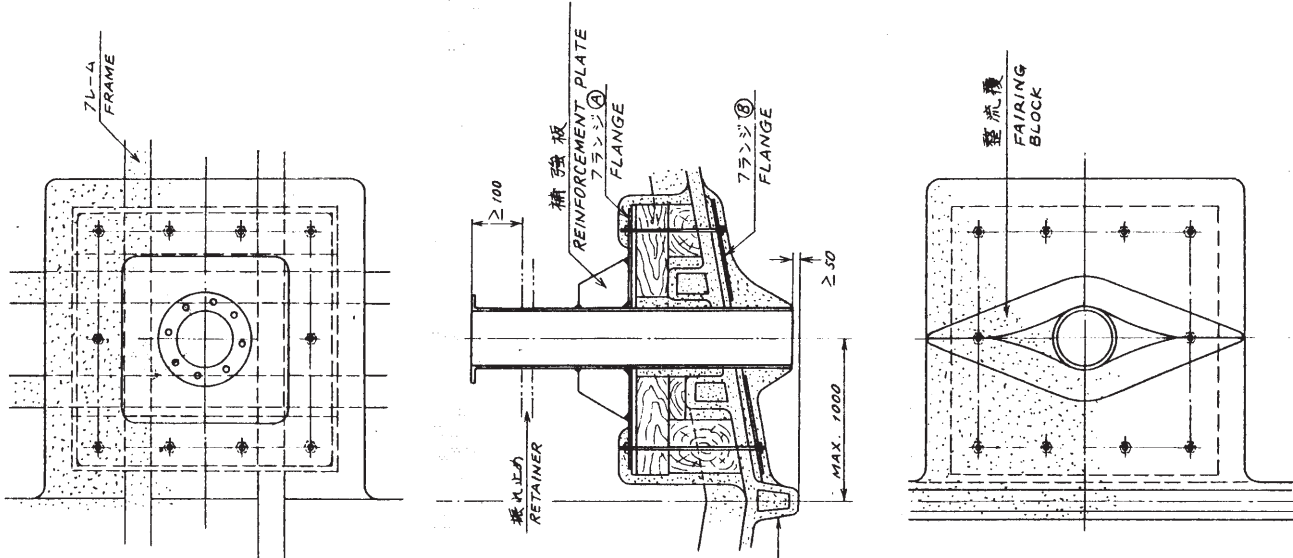

鋼製格納タンク外觀図
STEEL RETRACTION TANK
OUTLINE DRAWING

単位 UNIT: mm

- 格納タンクの準備は次の条件を満すこと。
 - 取付位置は船首から1/3 (小型船の場合は1/2) 程度。
 - キールより1m以内。
 - フランジのボルト締付のため、フランジ下面と隣接物 (二重船底等) との間に100mm以上のスペースがあること。
 - タンクの先端はキールの先端より50mm上であること。
 - タンクのフランジ面は横溝定航時に水平であること。

- 格納タンクの準備は、次の要領を参考にして行うこと。
 - フレーム間の船底にタンクが通る寸法を空ける。
 - タンクがあるいはタンクと同径の寸法を空通させ、その回りにフランジ(A)の取付け位置を決定し、FRPでフレーム、船底間に固定する。
 - フランジ(A)の取付位置に合わせて取付台にボルトを立立てておく。必要があればフランジ(B)を作りボルトも船底から空通させる。
 - FRP硬化後タンクがあるいは寸法を抜き取る。
 - フランジ(A)をタンクに接続する。
 - フランジ(A)下面及びタンク外面にFRPを必要箇所を塗り固める。特にタンク回りは流線型に成型し、海水を防止するため充分にFRPで必要箇所を最少限におこなう様努めること。
 - 水による抵抗及び気泡発生を最少限にする。
 - 必要に応じてタンクのフランジ下面下部100mmの位置より隔壁板に向けて横溝止めを設けること。またフランジ(A)を接続時、タンクの周囲3.4ヶ所をフランジ(A)に向けて、補強板を接続する。

注: 強度及び水密性について、船主、造船所担当者、施工者の間で充分協議し、取付位置、方法、材料等を決定すること。

- SATISFY THE FOLLOWING CONDITIONS IN DECIDING THE RETRACTION TANK MOUNTING SITE.
 - ABOUT 1/3 (1/2 IN CASE OF SMALL BOAT) OF SHIP'S LENGTH FROM BOW.
 - WITHIN 1000 mm FROM KEEL LINE.
 - ALLOW CLEARANCE OF MORE THAN 100 mm BENEATH TANK FLANGE TO FACILITATE BOLTING.
 - KEEP LOWEST END OF TANK 50 mm ABOVE BOTTOM OF KEEL.
 - TANK FLANGE SHOULD BE EXACTLY HORIZONTAL WHEN SHIP IS NORMALLY TRIMMED.

- INSTALL THE RETRACTION TANK REFERRING TO THE PROCEDURE BELOW.
 - CUT OUT A HOLE FOR PASSING THE TANK ON THE HULL PLATE.
 - PASS THE TANK OR A CORE HAVING THE SAME DIAMETER AS THE TANK THRU THE HULL PLATE. MAKE A MOUNTING BED WITH WOODEN BLOCK AND FRP AROUND THE TANK OR THE CORE. THIS BED IS USED TO MOUNT THE FLANGE (A).
 - WHEN FABRICATING THE MOUNTING BED, STAND THE BOLTS ON THE BED FOR FIXING THE FLANGE (A). IF NECESSARY, MAKE THE FLANGE (B) TO ENSURE FIXING OF THE FLANGE (A).
 - AFTER FRP IS STIFFENED, DRAW OUT THE TANK OR THE CORE FROM THE MOUNTING BED.
 - WELD THE FLANGE (A) TO THE TANK.
 - APPLY A STEEL-FRP ADHESIVE TO THE TANK AND THE FLANGE (A), AND INSTALL THE TANK WITH FLANGE (A) IN PLACE. SETTLE THE FLANGE (A) WITH BOLTS AND NUTS.
 - APPLY FRP AROUND THE PARTS OF THE TANK PROTRUDING FROM THE HULL BOTTOM FOR SUFFICIENT REINFORCEMENT. MAKE A FAIRING BLOCK WITH FRP AROUND THE PROTRUDING PARTS OF THE TANK TO MINIMIZE THE EFFECT OF AERATION.
 - IF REQUIRED, INSTALL A REINFORCEMENT PLATE WHEN THE FLANGE (A) IS WELDED TO THE TANK. IT IS ADVISABLE TO PROVIDE REINFORCEMENT ANGLES BETWEEN THE TANK AND THE ADJACENT BULKHEAD OR CEILING.

CAUTION: DISCUSSION SHOULD TAKE PLACE AND AGREEMENT BE REACHED WITH THE SHIPYARD FOR SUFFICIENT REINFORCEMENT AND WATERTIGHTNESS OF THE HULL TO COMPLY WITH THE REGULATIONS CONCERNED.

承認 APPROVED	品名 ITEM NAME	材質 MATERIAL	数量 QTY	図番 DWG.NO.	備考 REMARKS
NOV. 9. 1977	鋼製格納タンク	FRP			
NOV. 8. 1977	鋼製格納タンク船底接続部 (FRP船)	FRP			
NOV. 11. 1977	鋼製格納タンク船底接続部 (FRP船)	FRP			
NOV. 11. 1977	鋼製格納タンク船底接続部 (FRP船)	FRP			
NOV. 11. 1977	鋼製格納タンク船底接続部 (FRP船)	FRP			

CSH-5
CSH-5 MARK-2
CH-12/14/16/24/26

重量 WEIGHT
C1243-019-F

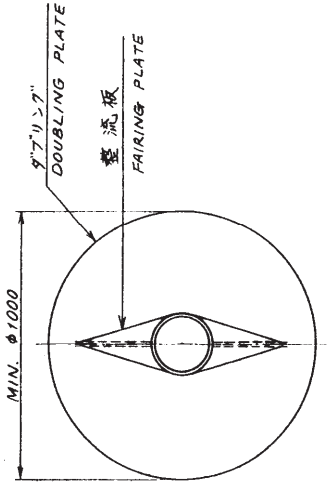
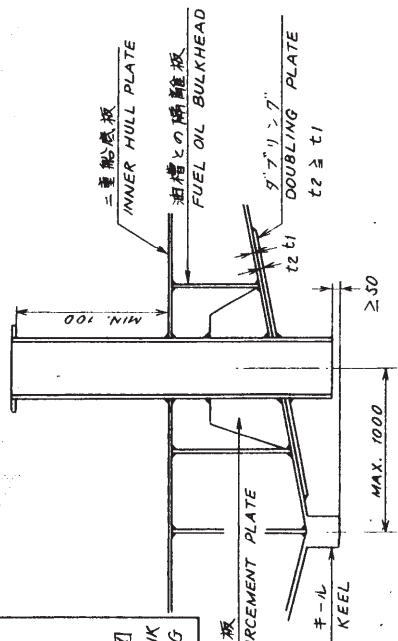
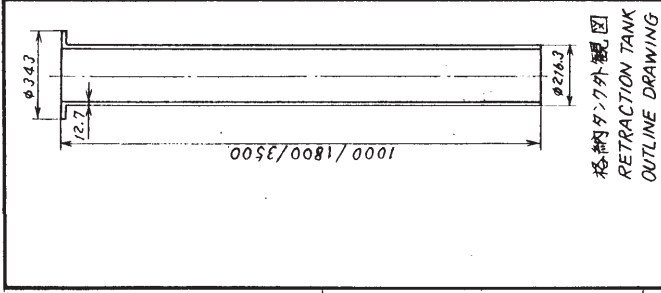

- 格納タンクの設備は次の条件を満たすこと。
1) 取付位置は船首から1/3 (小型船の場合は1/2) 程度。
2) キールより1m以内。
3) フランジのボルト締めのためのフランジ下面と構造物 (二重船殻等) との間に100mm以上のスペースがあること。
4) タンクの先端はキールの先端より50mm以上あること。
5) タンクのフランジ面は標準走航時に水平で保つこと。

- 格納タンクの周辺の船殻板に径1000程度のダブリングを施工すること。
- 格納タンクの突出部分に網除けを兼ねた整流板を設けること。
- 必要に応じて格納タンク周辺に油槽との隔離板をめぐらせること。
- またタンク周囲、3ヶ所所で船殻板に向けて補強板を逐層すること。

注: 強度及び水密性について、船主、造船所担当者、施工者の間で充分協議し、取付位置、方法、材料等を決定すること。

- SATISFY THE FOLLOWING CONDITIONS IN DECIDING THE RETRACTION TANK MOUNTING SITE.
 - ABOUT 1/3 (1/2 IN CASE OF SMALL BOAT) OF SHIP'S LENGTH FROM BOW ON FORE-AFT LINE.
 - WITHIN 1000 mm FROM KEEL LINE.
 - ALLOW CLEARANCE OF MORE THAN 100 mm BENEATH TANK FLANGE TO FACILITATE BOLTING.
 - KEEP LOWEST END OF TANK 50 mm ABOVE BOTTOM OF KEEL.
 - TANK FLANGE SHOULD BE EXACTLY HORIZONTAL WHEN SHIP IS NORMALLY TRIMMED.
- DOUBLING PLATE OF ABOUT 1000 mm IN DIA. SHOULD BE INSTALLED BY THE SHIPYARD.
- FAIRING PLATE (NET PROTECTOR) SHOULD BE INSTALLED AROUND THE PARTS OF THE TANK PROTRUDING FROM THE HULL BOTTOM BY THE SHIPYARD.
- IF REQUIRED, FUEL OIL BULKHEAD AND REINFORCEMENT PLATE SHOULD BE INSTALLED BY THE SHIPYARD.

CAUTION: DISCUSSION SHOULD TAKE PLACE AND AGREEMENT BE REACHED WITH THE SHIPYARD FOR SUFFICIENT REINFORCEMENT AND WATERTIGHTNESS OF THE HULL TO COMPLY WITH THE REGULATIONS CONCERNED.

品番 ITEM	品名 NAME	材質 MATERIAL	数量 QTY	国番 DWG.NO.	概要 REMARKS
承認 APPROVED	Nov. 9. 1977	三 角 法 THIRD ANGLE PROJECTION			名称 格納タンク船殻整流板図 (鋼船)
検 CHECKED	Nov. 8. 1977	R 度 SCALE			TITLE RETRACTION TANK INSTAL- LATION ON STEEL HULL
製 DRAWN	1977. 11. 7 M. H. Red	重 量 WEIGHT		国 番 DWG.NO.	C1243-017-F

CSH-5
CSH-5 MARK-2
CH-12/14/16/24/26

単位 UNIT: mm

- 格納タンクの設備は次の条件を満たすこと。
 1) 取付位置は船首から1/3 (小型船の場合は1/2) 程度。
 2) キールより1m以内。
 3) フランジのボルト締めのためのフランジ下面と隣接物 (二重船底等) との間は100mm以上のスペースがあること。
 4) タンクの底端はキールの先端より50mm以上であること。
 5) タンクのフランジ面は標準走航時に水平であること。
- 浸水を防ぐため、FRPで必要箇所を塗り固める。特にタンク面は流線型に成型し、水による気泡発生を最少限におさえ、様劣ること。
- 必要に応じてタンクのフランジ下面部100mmの位置より隔壁等に向けて掘り止めを設けること。

注：強度及び水密性について、船主、造船所担当者、施工者の間で充分協議し、取付位置、方法、材料等を決定すること。

- SATISFY THE FOLLOWING CONDITIONS IN DECIDING THE RETRACTION TANK MOUNTING SITE.
 - ABOUT 1/3 (1/2 IN CASE OF SMALL BOAT) OF SHIP'S LENGTH FROM BOW.
 - WITHIN 1000mm FROM KEEL LINE.
 - ALLOW CLEARANCE OF MORE THAN 100mm BENEATH TANK FLANGE TO FACILITATE BOLTING.
 - KEEP LOWEST END OF TANK 50mm ABOVE BOTTOM OF KEEL.
 - TANK FLANGE SHOULD BE EXACTLY HORIZONTAL WHEN SHIP IS NORMALLY TRIMMED.
- APPLY FRP AROUND THE PARTS OF THE TANK PROTRUDING FROM THE HULL BOTTOM FOR SUFFICIENT REINFORCEMENT. MAKE A FAIRING BLOCK WITH FRP AROUND THE PROTRUDING PARTS OF THE TANK TO MINIMIZE THE EFFECT OF AERATION.
- IT IS ADVISABLE TO PROVIDE REINFORCEMENT ANGLES BETWEEN THE TANK AND THE ADJACENT BULKHEAD OR CEILING.

CAUTION: DISCUSSION SHOULD TAKE PLACE AND AGREEMENT BE REACHED WITH THE SHIPYARD FOR SUFFICIENT REINFORCEMENT AND WATERTIGHTNESS OF THE HULL TO COMPLY WITH THE REGULATIONS CONCERNED.

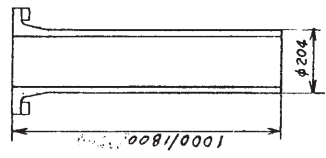
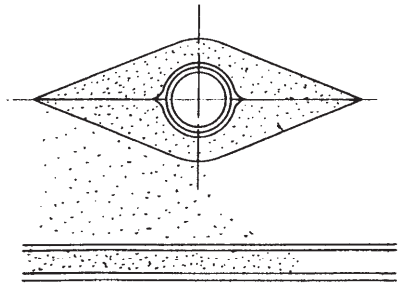
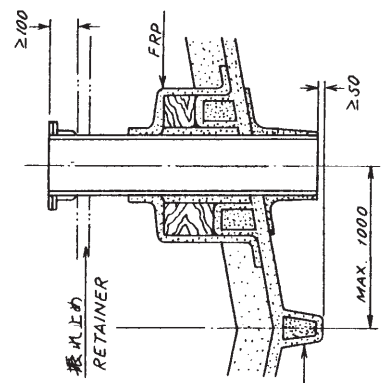
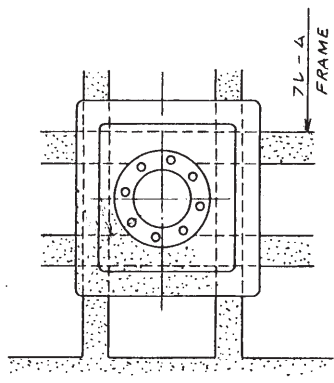

FRP製格納タンク外觀図
FRP RETRACTION TANK
OUTLINE DRAWING

承認 APPROVED	品番 ITEM	品名 NAME	材質 MATERIAL	数量 Q.TY	図番 DWG.NO.	備考 REMARKS
検 CHECKED		第三角法 THIRD ANGLE PROJECTION				
製 DRAWN		度 SCALE				
		重量 WEIGHT				
名 TITLE		FRP製格納タンク船底設備図 (FRP船)				
製 DRAWN		FRP RETRACTION TANK INSTALLATION ON FRP HULL				
図 DWG.NO.		C1220-038-F				

CSH-5
CSH-5 MARK-2
CH-12/14/16/24/26

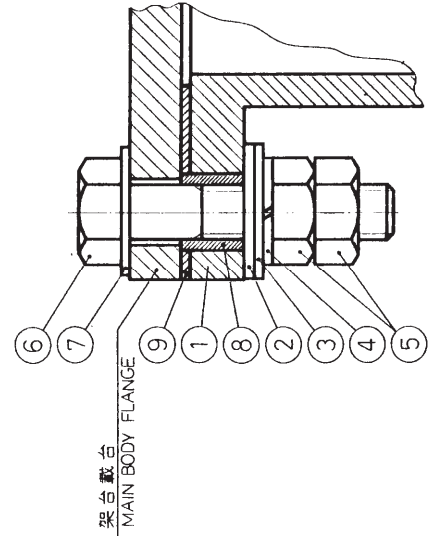
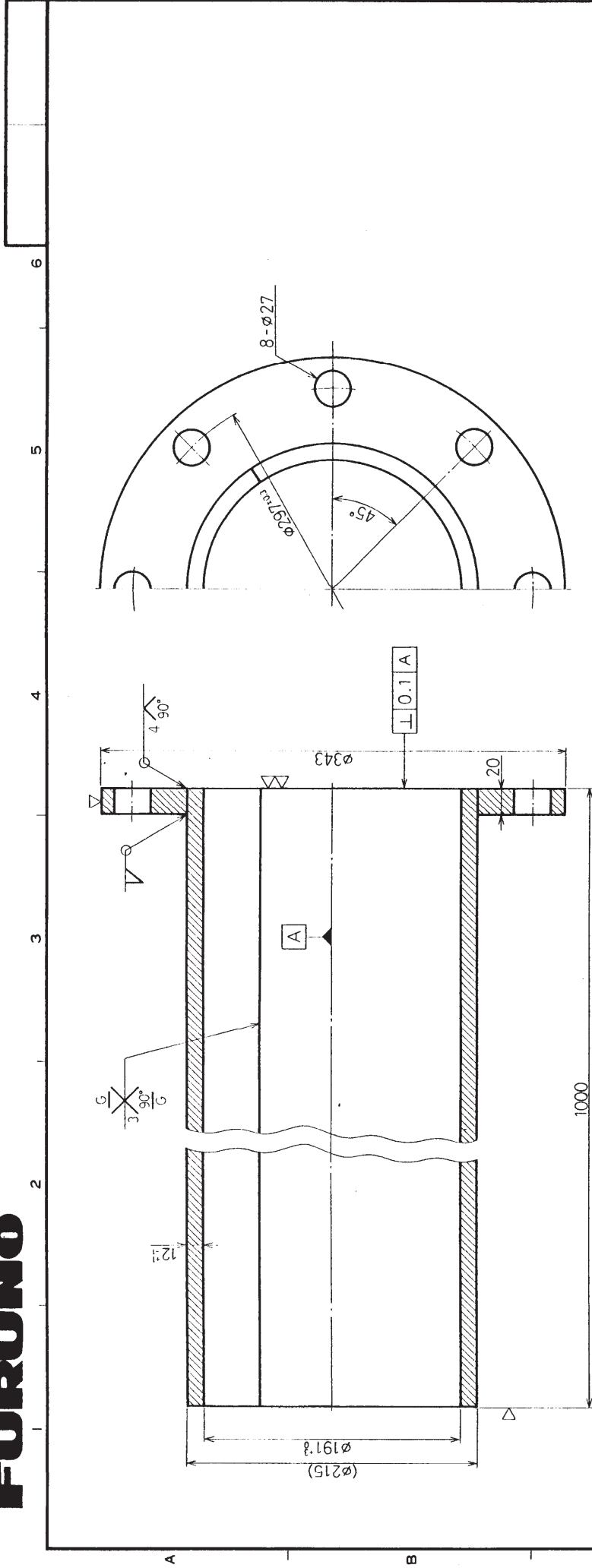

a) 格納タンク装備要領
ORIENTATION OF TANK

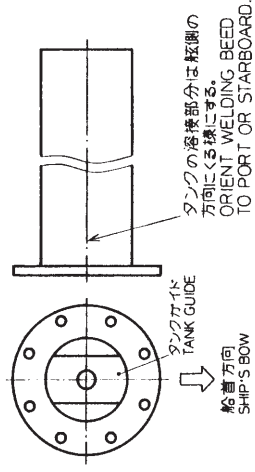

(注) 架台、格納タンクに他の電気機器のアースを取らないこと。
NOTE. DO NOT CONNECT GROUNDING WIRE OF OTHER EQUIPMENT TO RETRACTION TANK.

品番 ITEM	品名 NAME	材質 MATERIAL	数量 Q.TY	図番 DWG.NO.	備考 REMARKS
9	フランジパッキン GASKET	CR	1	SHJ-0009-1	
8	絶縁パッキン(2) INSULATION PACKING (2)	CR	8	MS-1000-68	
7	フランジワッシャー FLANGE WASHER	SUS304	8	M20用	
6	六角ボルト HEX. BOLT	SUS304	8	M20 x 100	
5	ナット NUT	SUS304	8	M20	
4	スプリングワッシャー SPRING WASHER		8		
3	ワッシャー WASHER	SUS304	8	SHG-0002	
2	絶縁板(2) INSULATION WASHER (2)	CR	8	SHG-0004	
1	格納タンク(アルミ) RETRACTION TANK	A5083	1	10-044-26011	

承認 APPROVED	DEC-27-90 T. AJIKAWA	第三角法 THIRD ANGLE PROJECTION	名 TITLE
検図 CHECKED	DEC-27-90 T. Miyoshi	尺 SCALE	格納タンク(アルミ)外寸図 RETRACTION TANK (ALUMINIUM)
製図 DRAWN	DEC-27-90 M. Usuda	重量 WEIGHT	3.5 kg
		図番 DWG. NO.	C1273-G09-A

CSH-5

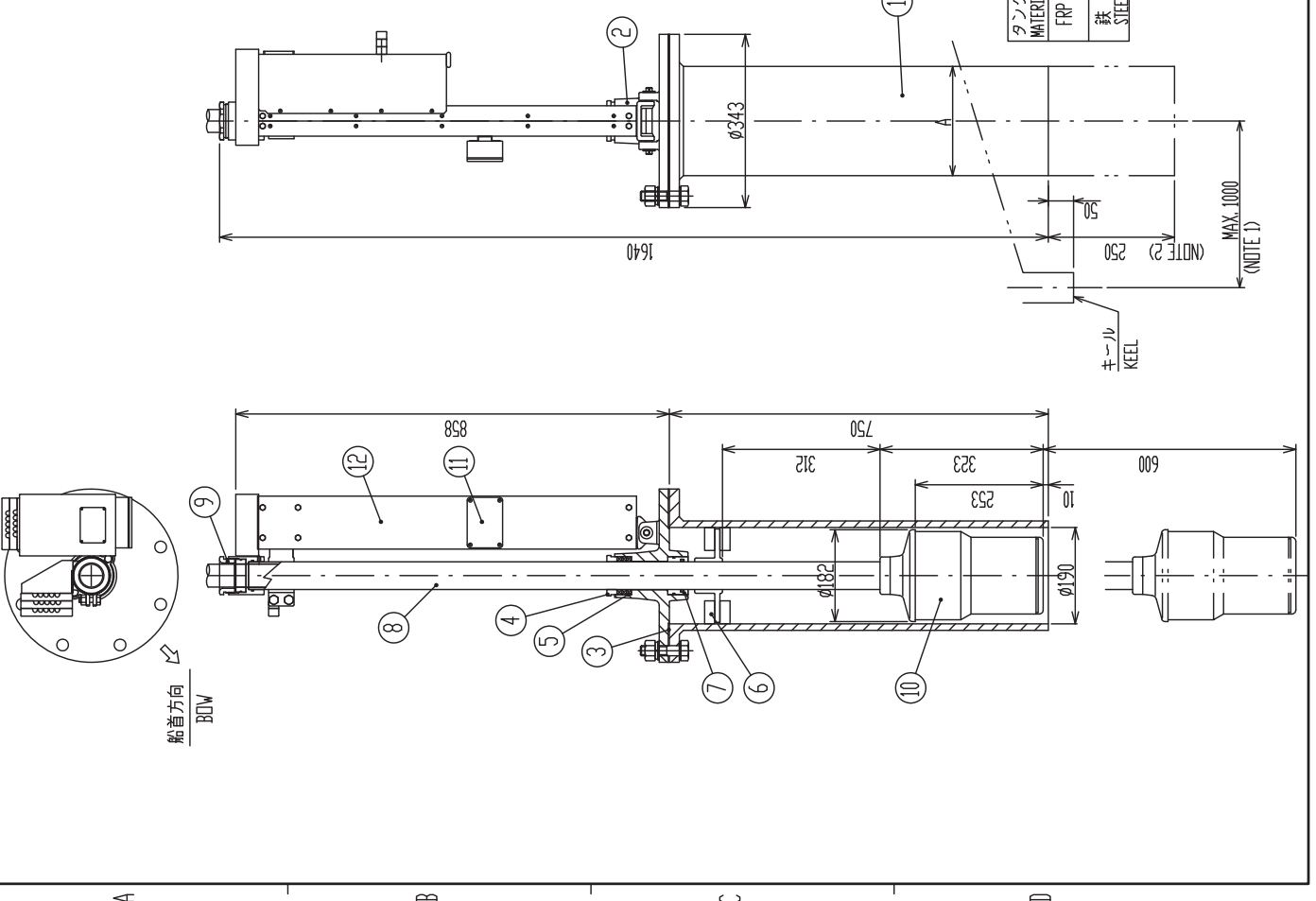
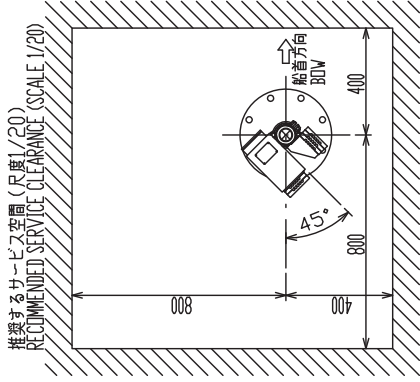

- 注記
- 1) 装備位置は船首から1/3 (小型船では1/2) 程度でキールから1 m以内とする。
 - 2) 格納タンクは装備位置に応じて250mm以内で切断する。
 - 3) 左図のごとく船首-船尾ラインと上下動部の角度が約45°となるよう装備する。
図では上下動部は左舷尾側に位置しているが、右舷尾側、左舷船首側、または、右舷船首側でもよい。
 - 4) 装備後は装備要領書を参照し船首線調整を行うこと。
- NOTE
- 1) THE HULL UNIT IS GENERALLY PLACED ABOUT 1/3 (1/2 IN CASE OF SMALL BOAT) OF THE SHIP'S LENGTH FROM THE BOW ON THE FORE-AFT LINE AND BESIDE THE KEEL LINE (LESS THAN 1000 mm FROM KEEL LINE).
 - 2) CUT THE TANK WITHIN 250 mm IN LENGTH ACCORDING TO INSTALLATION METHOD.
 - 3) THE HULL UNIT SHOULD BE ORIENTED SO THAT THE SHIP'S FORE-AFT LINE CROSSES THE RAISE LOWER DRIVE BLOCK AT AN ANGLE OF APPROXIMATELY 45°AS SHOWN AT LEFT. NOTE THAT POSITIONS WHICH ARE ROTATED IN 90°STEPS FROM THE SHOWN POSITION ARE ALSO ALLOWED.
 - 4) HEADING ADJUSTMENT SHOULD BE PERFORMED AFTER INSTALLATION. REFERRING TO THE INSTALLATION MANUAL.

品番 ITEM	品名 NAME	材質 MATERIAL	数量 QTY	図番 DRAWING NO.	備考 REMARKS
12	上下動部 RAISE/LOWER DRIVE BLOCK		1		
11	コネクタボックス CONNECTOR BOX		1		
10	送受波器 TRANSDUCER		1		
9	接止め器具 STOPPER		1		
8	上下シャフト(1) UP-DOWN SHAFT		1		
7	UP-パッキン UP-PACKING	ISI 55 55 6	1		
6	タンクガイド TANK GUIDE		1		
5	グリスコットン GREASE COTTON		1		D9.5x0.7m
4	グリスコットン押さえ台 GREASE COTTON RETAINER		1		
3	フランジパッキン GASKET	CR	1	SHJ-0009-1	
2	架台胴台 MAIN BODY FLANGE		1		
1	格納タンク RETRACTION TANK		1		質量に含まず NOT INCLUDED IN MASS 換算要 REMARKS

DRAWN	6/Feb/2015	I. YAMASAKI
CHECKED	6/Feb/2015	H. MAKI
APPROVED	6/Feb/2015	H. MAKI
SCALE	1/10	MASS 82 kg
DWG. No.	C1314-G03-F	
REF. No.	10-067-3000-G0	

品名 TITLE	名称	上下装置 (600mmストローク)
図番 DRAWING NO.	外寸図	
質量 MASS	質量は格納タンクを含まず	
スケール SCALE	1/10	
図番 DRAWING NO.	HULL UNIT (600mm TRAVEL)	
参照図番 REF. No.	10-067-3000-G0	
図名 TITLE	OUTLINE DRAWING	

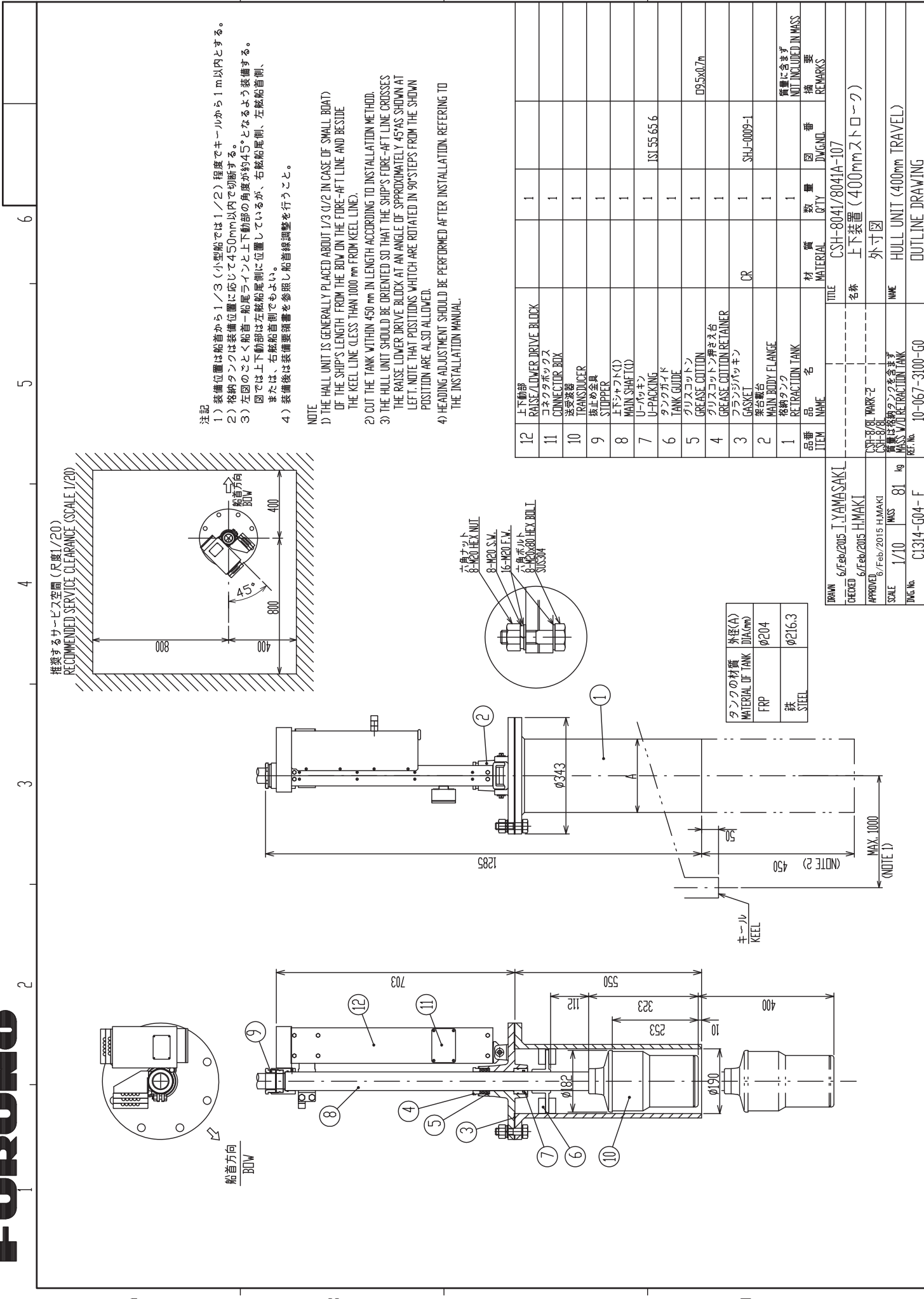

注記
 1) 装置位置は船首から1/3 (小型船では1/2) 程度でキールから1m以内とする。
 2) 格納タンクは装置位置に応じて450mm以内で切断する。
 3) 左図のごとく船首-船尾ラインと上下動部の角度が約45°となるよう装置する。
 図では上下動部は左舷船尾側に位置しているが、右舷船尾側、左舷船首側、または、右舷船首側でもよい。
 4) 装置後は装置要領書を参照し船首線調整を行うこと。

NOTE
 1) THE HULL UNIT IS GENERALLY PLACED ABOUT 1/3 (1/2 IN CASE OF SMALL BOAT) OF THE SHIP'S LENGTH FROM THE BOW ON THE FORE-AFT LINE AND BESIDE THE KEEL LINE (LESS THAN 1000 mm FROM KEEL LINE).
 2) CUT THE TANK WITHIN 450 mm IN LENGTH ACCORDING TO INSTALLATION METHOD.
 3) THE HULL UNIT SHOULD BE ORIENTED SO THAT THE SHIP'S FORE-AFT LINE CROSSES THE RAISE LOWER DRIVE BLOCK AT AN ANGLE OF APPROXIMATELY 45° AS SHOWN AT LEFT. NOTE THAT POSITIONS WHICH ARE ROTATED IN 90° STEPS FROM THE SHOWN POSITION ARE ALSO ALLOWED.
 4) HEADING ADJUSTMENT SHOULD BE PERFORMED AFTER INSTALLATION, REFERRING TO THE INSTALLATION MANUAL.

品番 ITEM	品名 NAME	材質 MATERIAL	数量 QTY	図番 DIM. NO.	補注 REMARKS
12	上下動部 RAISE/LOWER DRIVE BLOCK		1		
11	コネクタボックス CONNECTOR BOX		1		
10	送受波器 TRANSDUCER		1		
9	送受波器 取り付け金具 SLIPPER		1		
8	メインシャフト U-パッキン MAIN SHAFT(U) U-PACKING		1		
7	タンクガイド U-パッキン TANK GUIDE		1	JSL 55.65.6	
6	グリスコットン GREASE COTTON		1		
5	グリスコットン GREASE COTTON		1		095x07m
4	グリスコットン GREASE COTTON		1		
3	フランジ FRANZON パッキン MAIN BODY FLANGE GASKET	CR	1	SHJ-0009-1	
2	格納タンク RETRACTION TANK		1		質量に含まず NOT INCLUDED IN MASS
1	格納タンク RETRACTION TANK		1		

DRAWN	6/Feb/2015	T. YAMASAKI
CHECKED	6/Feb/2015	H. MAKI
APPROVED	6/Feb/2015	H. MAKI
SCALE	1/10	MASS 81 kg
DWG. No.	C1314-G04-F	
TITLE	CSH-8041/8041A-107	
名称	上下装置 (400mm ストローク)	
外形図		
WAVE	HULL UNIT (400mm TRAVEL)	
OUTLINE DRAWING		

タンクの材質 MATERIAL OF TANK	外径(A) DIA.(mm)
FRP	φ204
鉄 STEEL	φ216.3

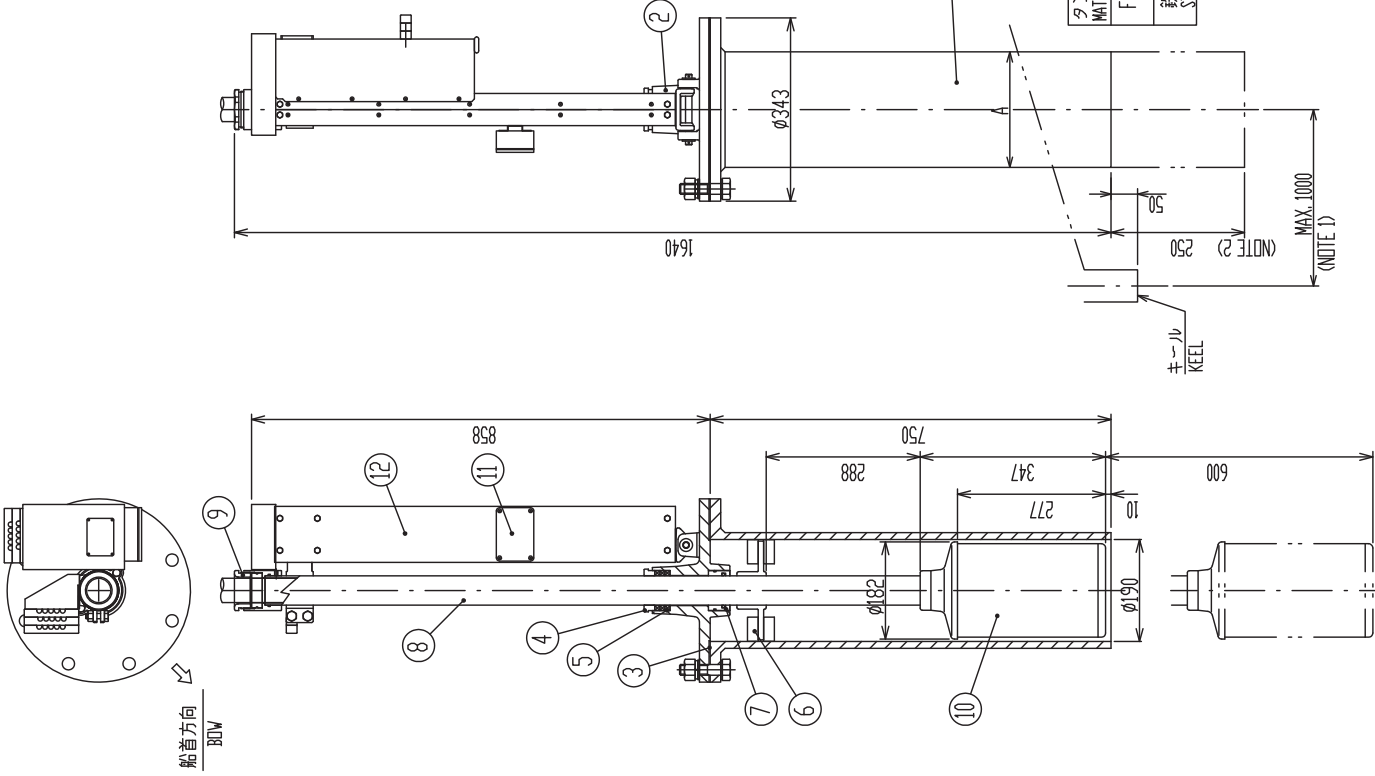
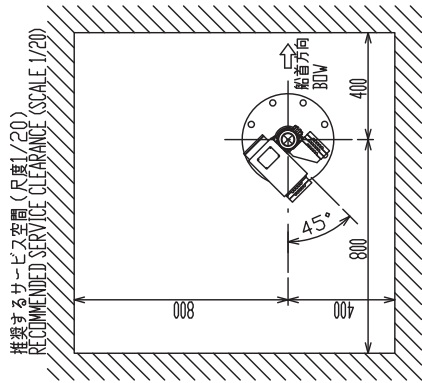

- 注記
- 1) 装備位置は船首から1/3 (小型船では1/2) 程度でキールから1 m以内とする。
 - 2) 格納タンクは装備位置に応じて250mm以内で切断する。
 - 3) 左図のごとく船首-船尾ラインと上下動部の角度が約45°となるよう装備する。図では上下動部は左舷船尾側に位置しているが、右舷船尾側、左舷船首側、または、右舷船首側でもよい。
 - 4) 装備後は装備要領書を参照し船首線調整を行うこと。

- NOTE
- 1) THE HULL UNIT IS GENERALLY PLACED ABOUT 1/3 (1/2 IN CASE OF SMALL BOAT) OF THE SHIP'S LENGTH FROM THE BOW ON THE FORE-AFT LINE AND BESIDE THE KEEL LINE (LESS THAN 1000 mm FROM KEEL LINE).
 - 2) CUT THE TANK WITHIN 250 mm IN LENGTH ACCORDING TO INSTALLATION METHOD.
 - 3) THE HULL UNIT SHOULD BE ORIENTED SO THAT THE SHIP'S FORE-AFT LINE CROSSES THE RAISE LOWER DRIVE BLOCK AT AN ANGLE OF APPROXIMATELY 45° AS SHOWN AT LEFT. NOTE THAT POSITIONS WHICH ARE ROTATED IN 90° STEPS FROM THE SHOWN POSITION ARE ALSO ALLOWED.
 - 4) HEADING ADJUSTMENT SHOULD BE PERFORMED AFTER INSTALLATION, REFERRING TO THE INSTALLATION MANUAL.

品番	品名	材質	数量	国番	図番	REMARKS
12	上下動部 RAISE/LOWER DRIVE BLOCK		1			
11	コネクタボックス CONNECTOR BOX		1			
10	送受波器 TRANS-DUCER		1			
9	送受波器 STOPPER		1			
8	メインシャフト MAIN SHAFT (C)		1			
7	U-パッキン U-PACKING		1			
6	タンクガイド TANK GUIDE		1		IST 55 65 6	
5	グリスコットン GREASE COTTON		1			09.5φx7m
4	グリスコットン押さえ台 GREASE COTTON RETAINER		1			
3	フランジパッキン GASKET	CR	1		SHJ-0009-1	
2	本体フランジ MAIN BODY FLANGE		1			
1	格納タンク RETRACTION TANK		1			質量に含まず NOT INCLUDED IN MASS

DRAWN	6/Feb/2015	T. YAMASAKI
CHECKED	6/Feb/2015	H. MAKI
APPROVED	6/Feb/2015	H. MAKI
SCALE	1/10	MASS 85 kg
DWG. No.	C1314-G05-D	

品名	CSH-8040/8040A-85
名称	上下装置 (600mmストローク)
外形図	
質量	85 kg
質量に含まず	格納タンクを含まず
図番	CSH-8040
国番	
図名	HULL UNIT (600mm TRAVEL)
図種	OUTLINE DRAWING

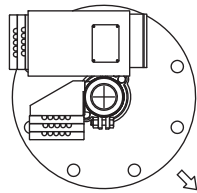
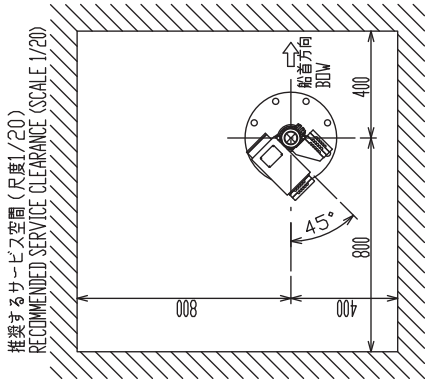

船首方向
BOW

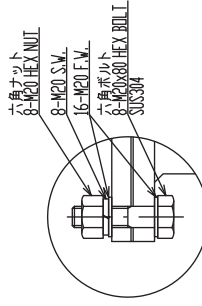
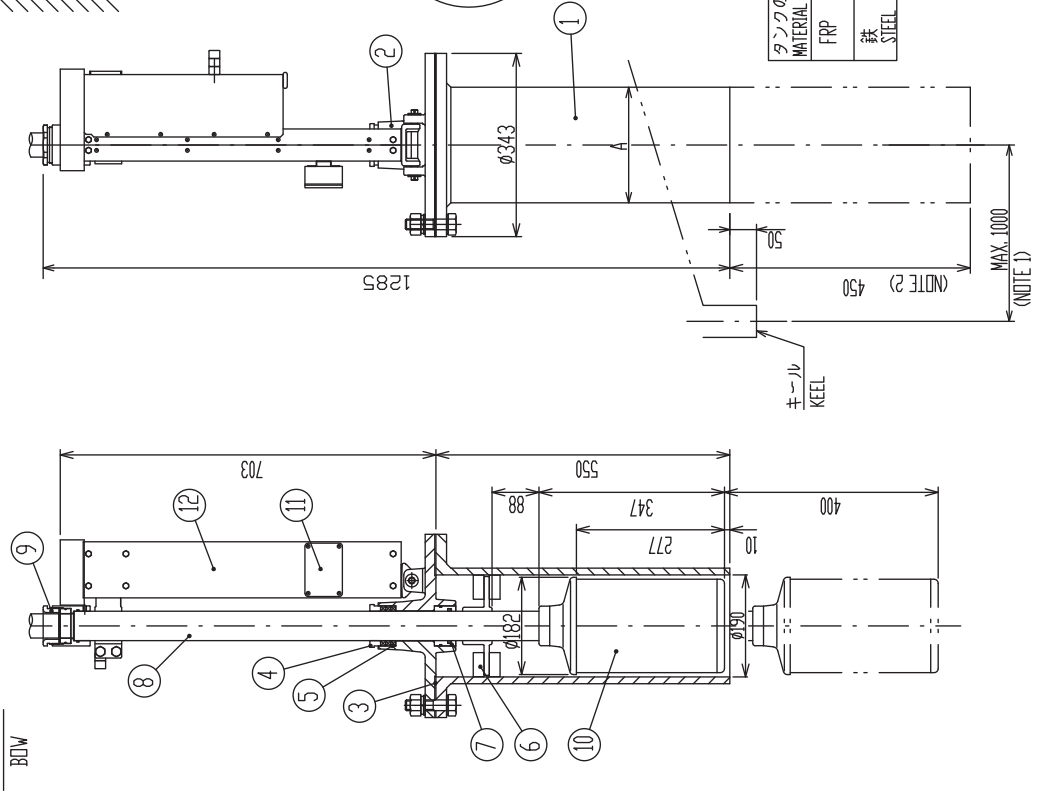

タンクの材質 MATERIAL OF TANK	FRP
外径(A) DIA.(mm)	φ204
鋼板厚 STEEL	φ216.3

- 注記
- 1) 装備位置は船首から1/3 (小型船では1/2) 程度でキールから1 m以内とする。
 - 2) 格納タンクは装備位置に応じて450mm以内で切断する。
 - 3) 左図のごとく船首-船尾ラインと上下動部の角度が約45°となるよう装備する。図では上下動部は左舷船尾側に位置しているが、右舷船尾側、左舷船首側、または、右舷船首側でもよい。
 - 4) 装備後は装備要領書を参照し船首線調整を行うこと。

NOTE

- 1) THE HULL UNIT IS GENERALLY PLACED ABOUT 1/3 (1/2 IN CASE OF SMALL BOAT) OF THE SHIP'S LENGTH FROM THE BOW ON THE FORE-AFT LINE AND BESIDE THE KEEL LINE (LESS THAN 1000 mm FROM KEEL LINE).
- 2) CUT THE TANK WITHIN 450 mm IN LENGTH ACCORDING TO INSTALLATION METHOD.
- 3) THE HULL UNIT SHOULD BE ORIENTED SO THAT THE SHIP'S FORE-AFT LINE CROSSES THE RAISE LOWER DRIVE BLOCK AT AN ANGLE OF APPROXIMATELY 45°AS SHOWN AT LEFT. NOTE THAT POSITIONS WHICH ARE ROTATED IN 90°STEPS FROM THE SHOWN POSITION ARE ALSO ALLOWED.
- 4) HEADING ADJUSTMENT SHOULD BE PERFORMED AFTER INSTALLATION, REFERRING TO THE INSTALLATION MANUAL.

品番 ITEM	品名 NAME	材質 MATERIAL	数量 QTY	国番 DIV.NO.	備考 REMARKS
12	上下動部 RAISE/LOWER DRIVE BLOCK		1		
11	コネクタボックス CONNECTOR BOX		1		
10	送電線 TRANSUDER		1		
9	緩止め器具 STOPPER		1		
8	上下シャフト(1) U-PAKING		1		
7	U-PAKING		1	ISI 55.65.6	
6	タンクガイド TANK GUIDE		1		
5	グリスコットン GREASE COTTON		1		D9.5x0.7m
4	グリスコットン押さえ台 GREASE COTTON RETAINER		1		
3	フランジパッキン GASKET	CR	1	SHJ-0009-1	
2	架台胴台 MAIN BODY FLANGE		1		
1	格納タンク RETRACTION TANK		1		質量に含みず NOT INCLUDED IN MASS

DRAWN	ZAC/2/2021	T.YAMASAKI
CHECKED	ZAC/2/2021	H.MAKI
APPROVED	7/0ct/2021	H.MAKI
SCALE	1/10	MASS 84 kg
DWG. No.	C1314-G06-E	

品名	CSH-8041/8041A-85
名称	上下装置 (400mmストローク)
外寸図	
WAVE	HULL UNIT (400mm TRAVEL)
OUTLINE DRAWING	



表1 TABLE 1

寸法区分 (mm) DIMENSION	公差 (mm) TOLERANCE
$L \leq 50$	± 1.5
$50 < L \leq 100$	± 2.5
$100 < L \leq 500$	± 3
$500 < L \leq 1000$	± 4

- 注 記 1) #印寸法は最小サービス空間寸法とする。
 2) 指定外の寸法公差は表1による。
 3) 取付用ネジはM10ボルトを使用のこと。

- NOTE 1. TABLE 1 INDICATES TOLERANCE OF DIMENSIONS WHICH IS NOT SPECIFIED.
 2. #: MINIMUM SERVICE CLEARANCE.
 3. USE M10 BOLTS FOR FIXING THE UNIT.

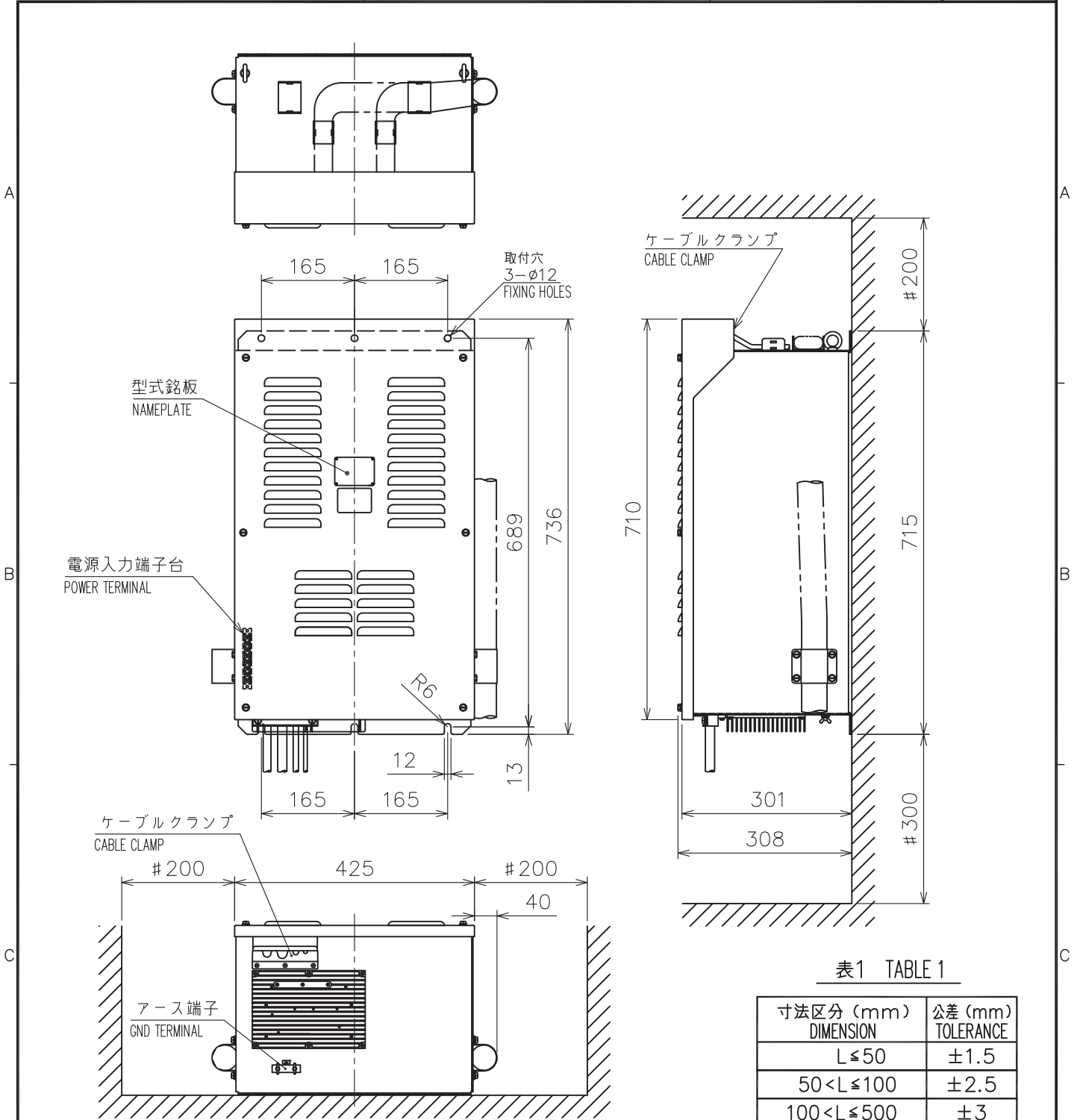
DRAWN	16/Jun/2015 T.YAMASAKI	TITLE	CSH-8030/8030A
CHECKED	16/Jun/2015 H.MAKI	名称	送受信装置
APPROVED	17/Jun/2015 H.MAKI		外寸図
SCALE	1/10	MASS	37 ±10% kg
DWG. No.	C1314-G01-E	REF. No.	10-067-200G-4
		NAME	TRANSCEIVER UNIT OUTLINE DRAWING

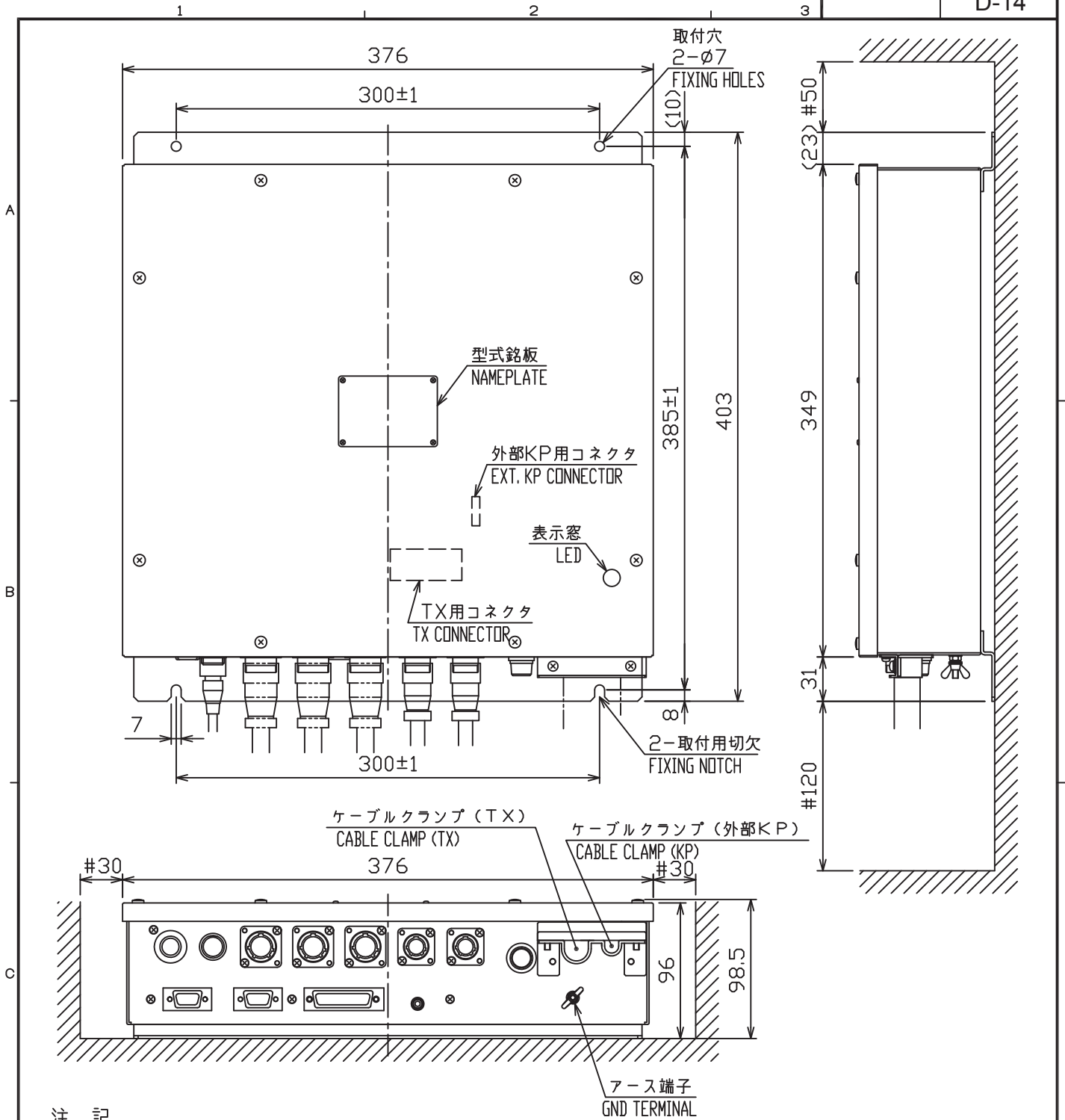

注 記

- 1) 指定外の寸法公差は表 1 による。
- 2) #印寸法は最小サービス空間寸法とする。
- 3) 取付用ネジはM6 ボルトまたはコーチねじ呼び径6を使用のこと。

NOTE

1. TABLE 1 INDICATES TOLERANCE OF DIMENSIONS WHICH IS NOT SPECIFIED.
2. #: MINIMUM SERVICE CLEARANCE.
3. USE M6 BOLTS OR COACH SCREWS φ6 FOR FIXING THE UNIT.

表 1 TABLE 1

寸法区分 (mm) DIMENSION	公差 (mm) TOLERANCE
L ≤ 50	± 1.5
50 < L ≤ 100	± 2.5
100 < L ≤ 500	± 3

DRAWN 5/Feb/2015 T.YAMASAKI		TITLE CSH-5210/5210A
CHECKED 5/Feb/2015 H.MAKI		名称 制御部
APPROVED 6/Feb/2015 H.MAKI	CSH-5L78L MARK-2 CSH-5L/8L	外寸図
SCALE 1/4	MASS 3.4 ±10% kg	NAME PROCESSOR UNIT
DWG. No. C1319-G01-C	REF. No. 10-078-300G-1	OUTLINE DRAWING



表 1 TABLE 1

寸法区分 (mm) DIMENSION	公差 (mm) TOLERANCE
L ≤ 50	±1.5
50 < L ≤ 100	±2.5
100 < L ≤ 500	±3

注 記

- 1) 指定外の寸法公差は表 1 による。
- 2) # 印寸法は最小サービスクリアランスとする。
- 3) 取付用ネジは M5 ボルトまたはトラスタップピンネジ呼び径 5 を使用のこと。

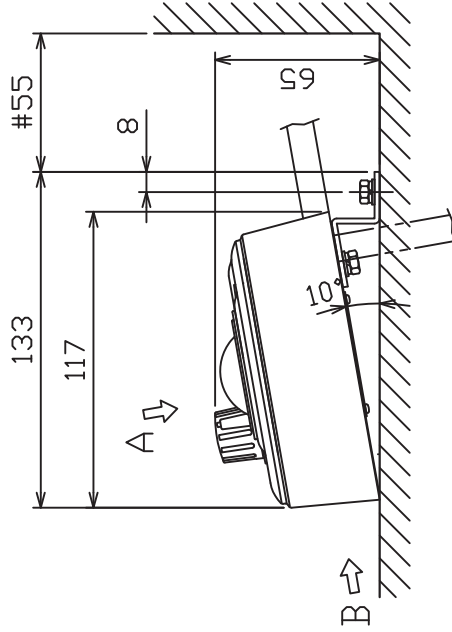
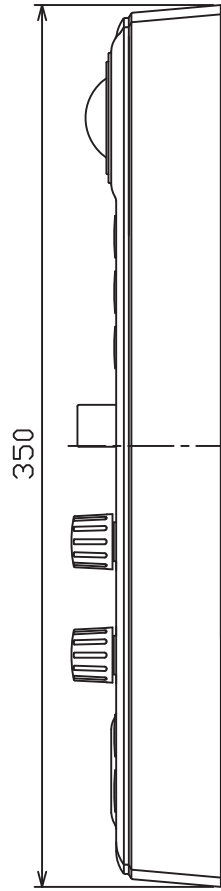
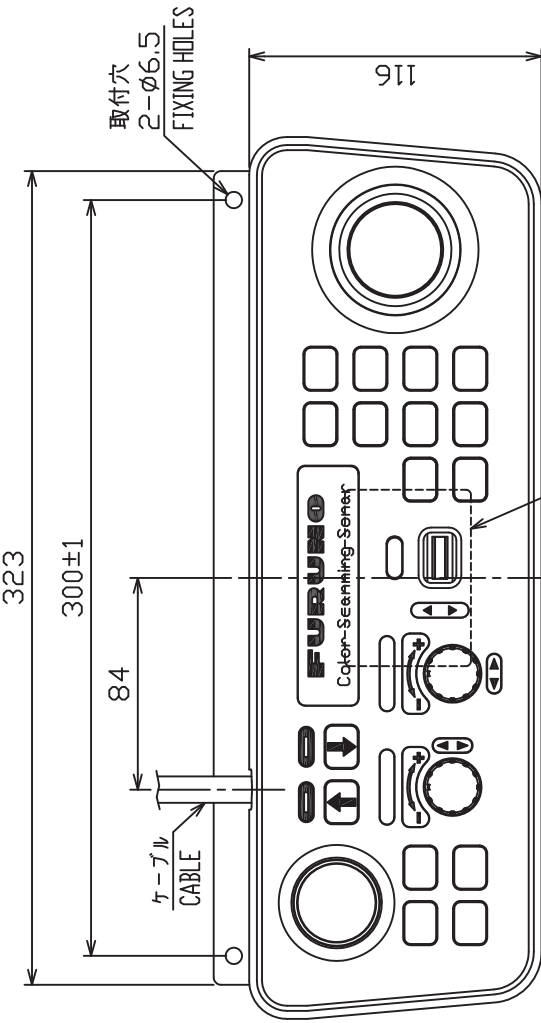
NOTE

1. TABLE 1 INDICATES TOLERANCE OF DIMENSIONS WHICH IS NOT SPECIFIED.
2. # MINIMUM SERVICE CLEARANCE.
3. USE M5 BOLTS OR TAPPING SCREWS φ5 FOR FIXING THE UNIT.

DRAWN	26/Mar/2015	I.YAMASAKI	TITLE	CSH-5211/5211A
CHECKED	26/Mar/2015	H.MAKI	名称	操作部 (卓上装備、金具付)
APPROVED	30/Mar/2015	H.MAKI	外寸図	
SCALE	1/3	質量 2.8 kg	NAME	CONTROL UNIT (TABLETOP MOUNT W/ FIXTURE)
DWG.No.	C1319-G02-D	質量はケーブル (5m) を含む。 MASS INCLUDES 5m CABLE.	REF.No.	10-078-200G-2
				OUTLINE DRAWING

表 1 TABLE 1

寸法区分 (mm) DIMENSION	公差 (mm) TOLERANCE
$L \leq 50$	± 1.5
$50 < L \leq 100$	± 2.5
$100 < L \leq 500$	± 3

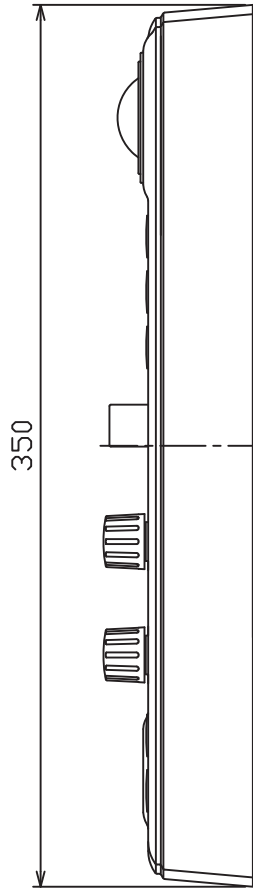
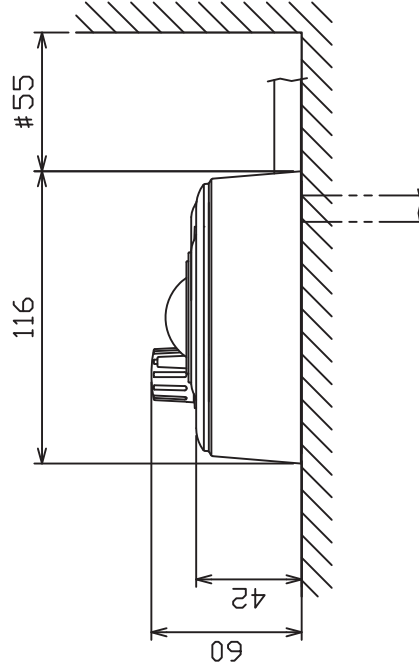
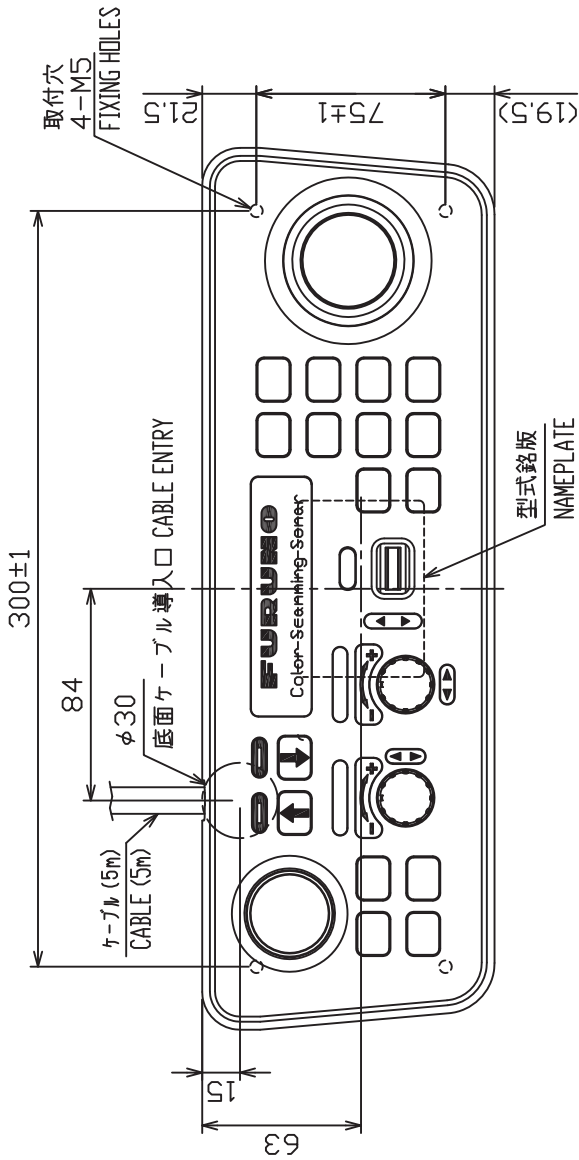

注 記

- 1) 指定外の寸法公差は表 1 による。
- 2) # 印寸法は最小サービス空間寸法とする。
- 3) 取付用ネジは M5 ボルトを使用のこと。
ボルトが内部に 12 mm 以上入り込まないこと。

NOTE

1. TABLE 1 INDICATES TOLERANCE OF DIMENSIONS WHICH IS NOT SPECIFIED.
2. # MINIMUM SERVICE CLEARANCE.
3. USE M5 BOLTS FOR FIXING THE UNIT.
DO NOT FASTEN BOLTS INTO UNIT 12 mm OR MORE.

DRAWN	5/Feb/2015	I.YAMASAKI	TITLE	CSH-5211/5211A
CHECKED	5/Feb/2015	H.MAKI	名称	操作部 (卓上装備)
APPROVED	9/Feb/2015	H.MAKI	外寸図	
SCALE	1/3	質量はケーブルを含む。 ±10% MASS INCLUDES CABLE.	NAME	CONTROL UNIT (TABLETOP MOUNT)
DWG. No.	CI319-G03-C		REF. No.	10-078-201G-1

OUTLINE DRAWING

3 4

表1 TABLE 1

寸法区分(mm) DIMENSION	公差(mm) TOLERANCE
0 < L ≤ 50	±1.5
50 < L ≤ 100	±2.5
100 < L ≤ 500	±3

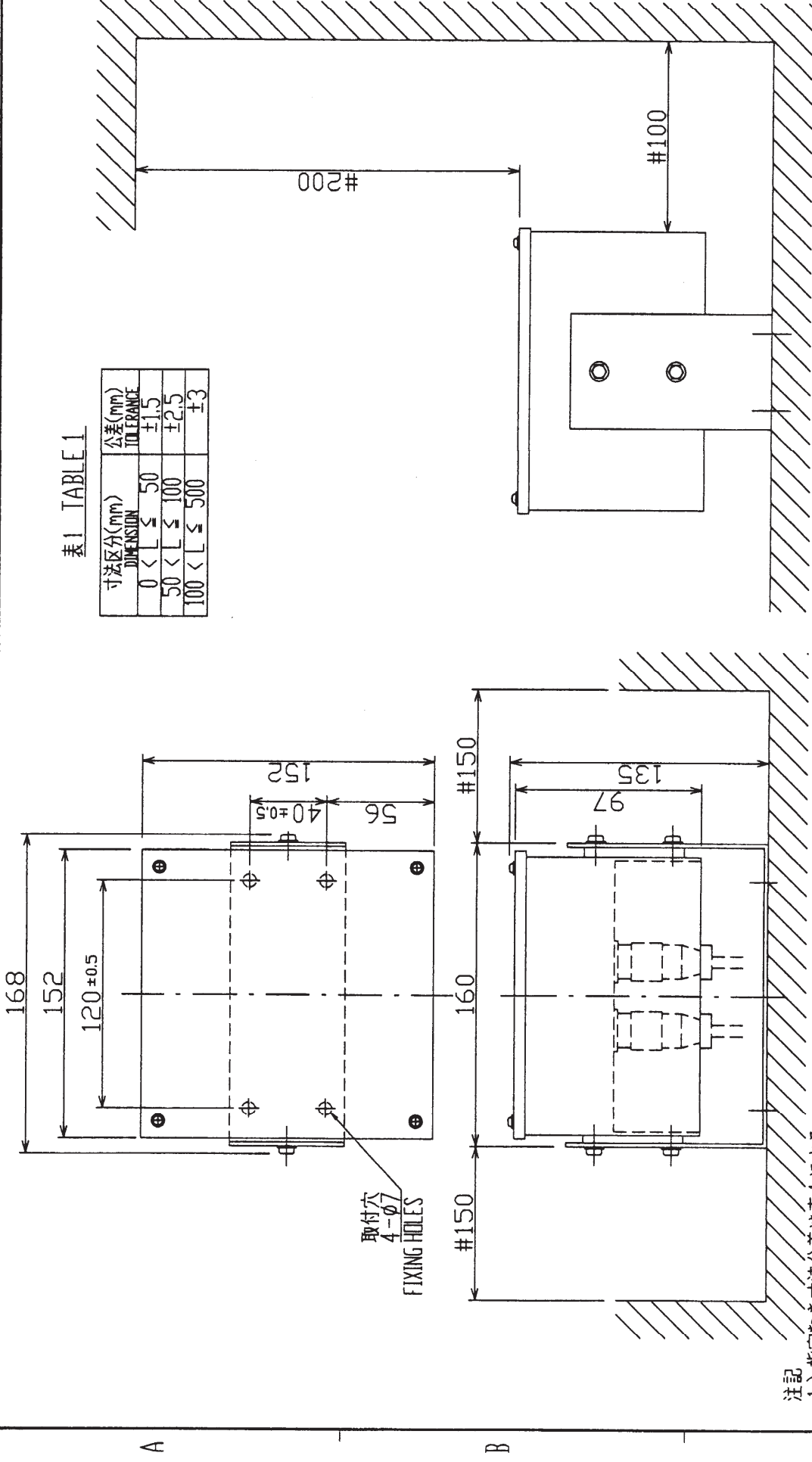

取付穴
4-φ7
FIXING HOLES

- 注記
- 1) 指定なき寸法公差は表1による。
 - 2) #; 推奨する最小サービス空間寸法。
 - 3) 船首マーク(FORE)を船首方向に向けて、きょう体を水平に取り付けること。

NOTE

1. TABLE 1 INDICATES TOLERANCE OF DIMENSIONS.
2. #; RECOMMENDED SERVICE CLEARANCE.
3. ORIENT THE 'FORE' MARK ON THE UNIT TOWARD SHIP'S BOW AND MOUNT THE UNIT LEVEL IN PARALLEL WITH SURFACE.

DRAWN NO. 6.01 I.YAMASAKI	TITLE MS-100
CHECKED MAY 6 '01 Y. K.	名称 動揺検出器
APPROVED MAY 6 '01 Y. K.	外寸図
SCALE 1/3	NAME MOTION SENSOR
MASS 1.1 kg	OUTLINE DRAWING
DWG. NO. C1278-601-B	

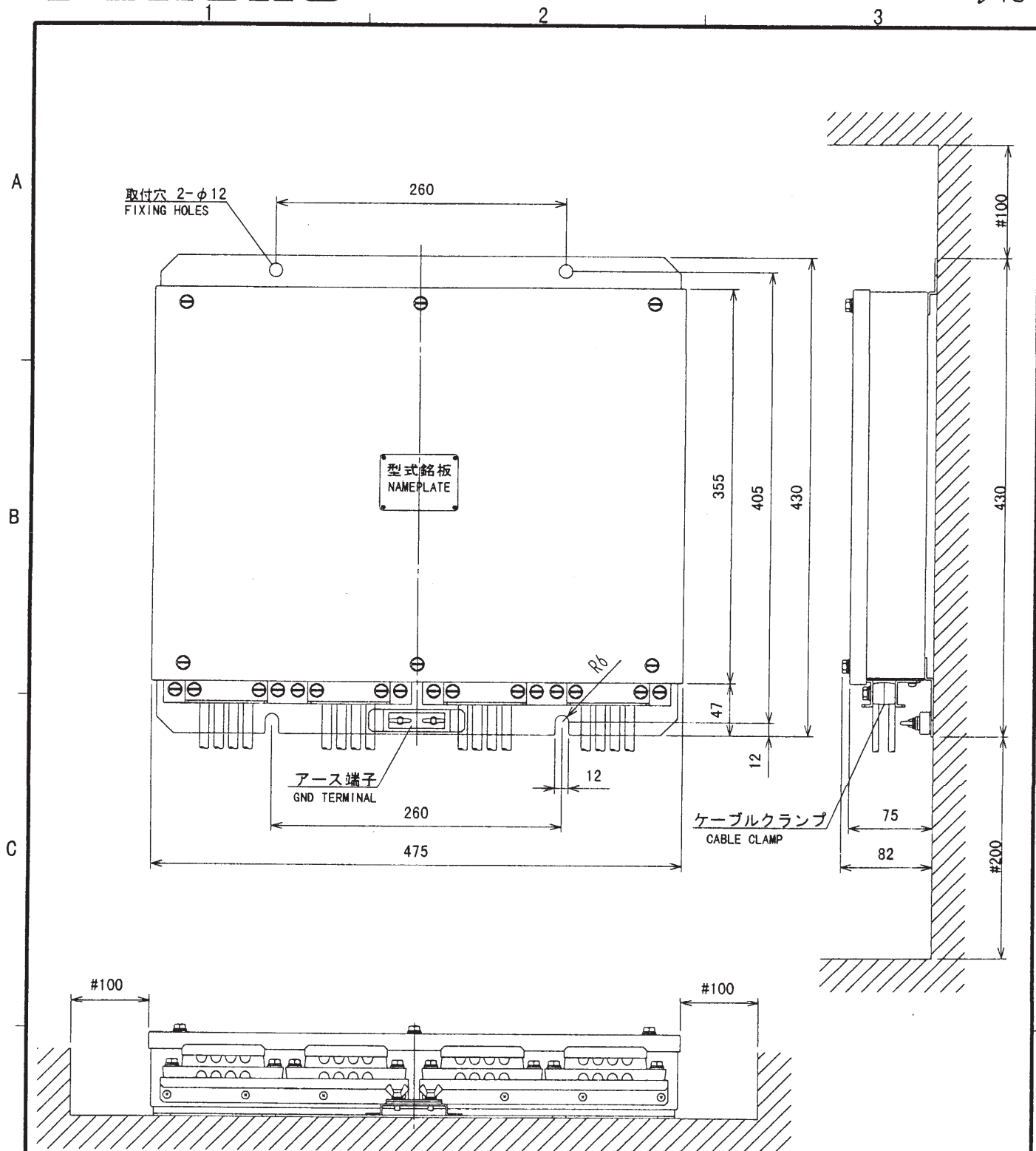

DRAWN July 13 '98 T. YAMASAKI		TITLE CSH-1700
CHECKED July 14 '99 K. Kusunoki		名称 振動子ケーブル延長キット
APPROVED July 14 '99 K. Kusunoki	CSH-5 MARK-2 CSH-8	外寸図
SCALE 1/5	MASS 8.0 kg	NAME TRANSDUCER CABLE EXTENTION KIT
DWG. No. C1314-G02- B	10-067-5000-G1	OUTLINE DRAWING

寸法区分 (mm) DIMENSION	公差 (mm) TOLERANCE
$0 < L \leq 50$	± 1.5
$50 < L \leq 100$	± 2.5
$100 < L \leq 500$	± 3

表 1
TABLE 1

A

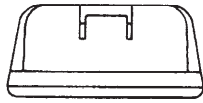

B

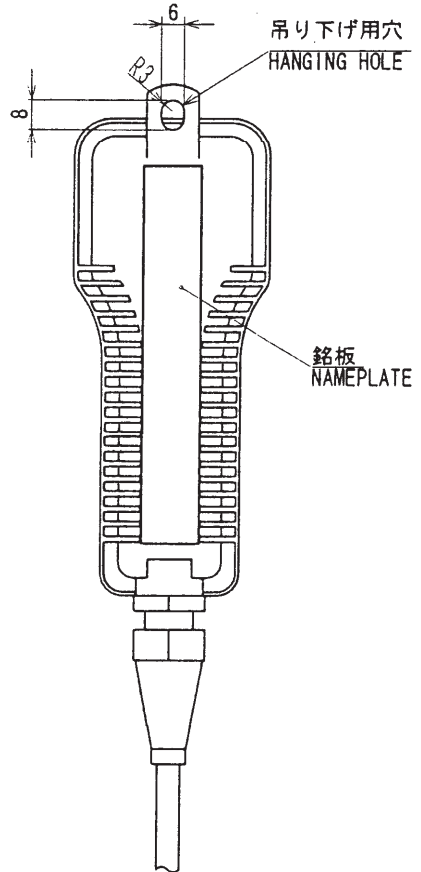
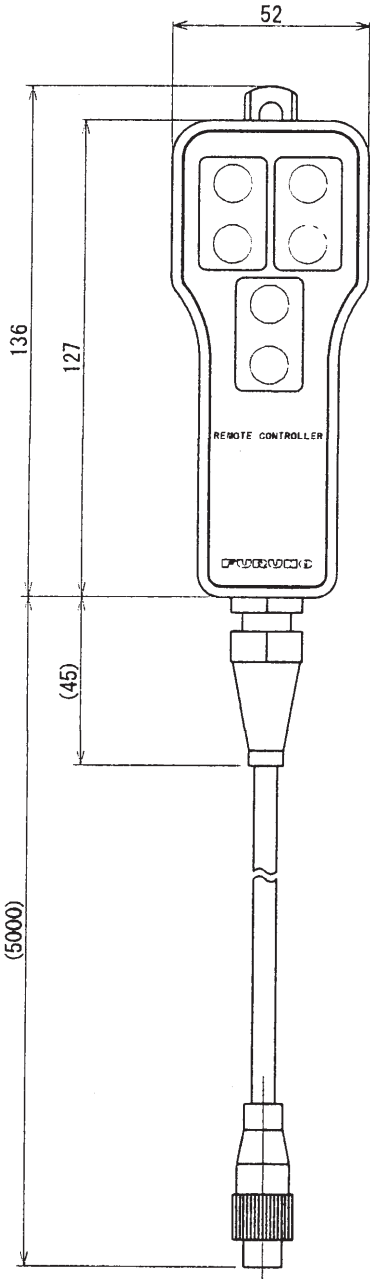

C

(5000)

D

注記 1) 指定なき寸法公差は表 1 による。

NOTE 1. TABLE 1 INDICATES TOLERANCE OF DIMENSIONS.

DRAWN <i>Sept 21 '00 T. YAMASAKI</i>		TITLE	CSH-7040
CHECKED <i>Sept 21 '00 T. Yam</i>		名称	リモートコントローラ
APPROVED <i>Sept 21 '00 Y. K.</i>	CSH-7	外寸図	
SCALE 1/2	MASS $\pm 10\%$ 0.25 kg	質量はケーブル重さを含む MASS W/ CABLE	NAME REMOTE CONTROLLER
DWG. No.	C1302-G05-B	10-061-5000- G1	OUTLINE DRAWING

表1 TABLE 1

寸法区分(mm) DIMENSIONS	公差(mm) TOLERANCE
0 < L ≤ 50	±1.5
50 < L ≤ 100	±2.5
100 < L ≤ 500	±3

A

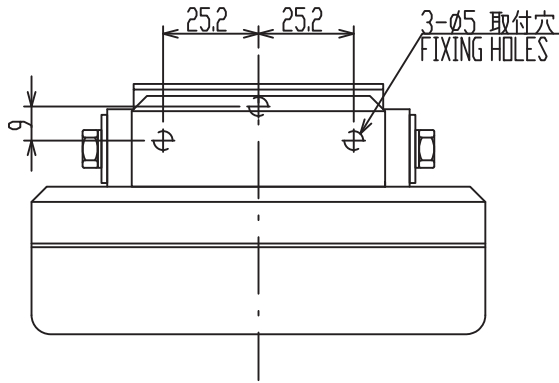

B

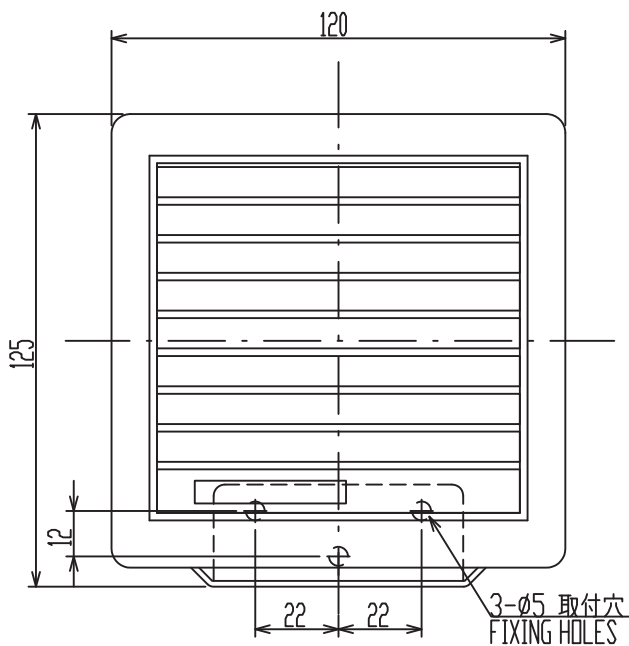

C

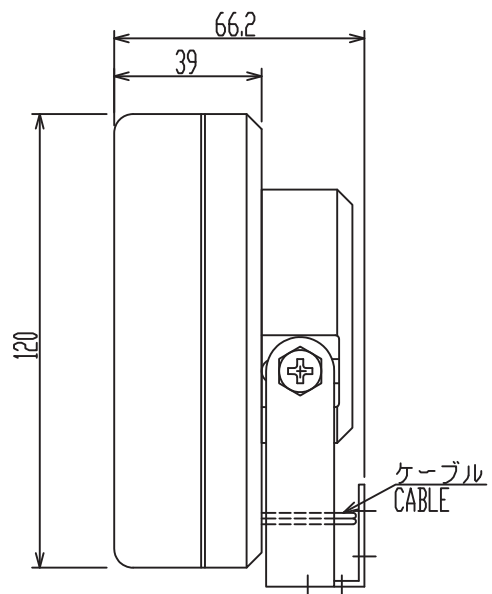

D

注記 1) 指定外寸法公差は表1による。

NOTE 1. TABLE 1 INDICATES TOLERANCE OF DIMENSIONS WHICH IS NOT SPECIFIED.

DRAWN	Nov. 25, '06	E. MIYOSHI	TITLE	SEM-21Q
CHECKED		TAKAHASHI, T	名称	スピーカ
APPROVED		Y. Hatai		外寸図
SCALE	1/2	MASS 0.54 ±10% kg	質量は2.8mケーブルを含む MASS W/ 2.8m CABLE	NAME
DWG.No.	C5016-G07-C		REF.No.	LOUDSPEAKER OUTLINE DRAWING

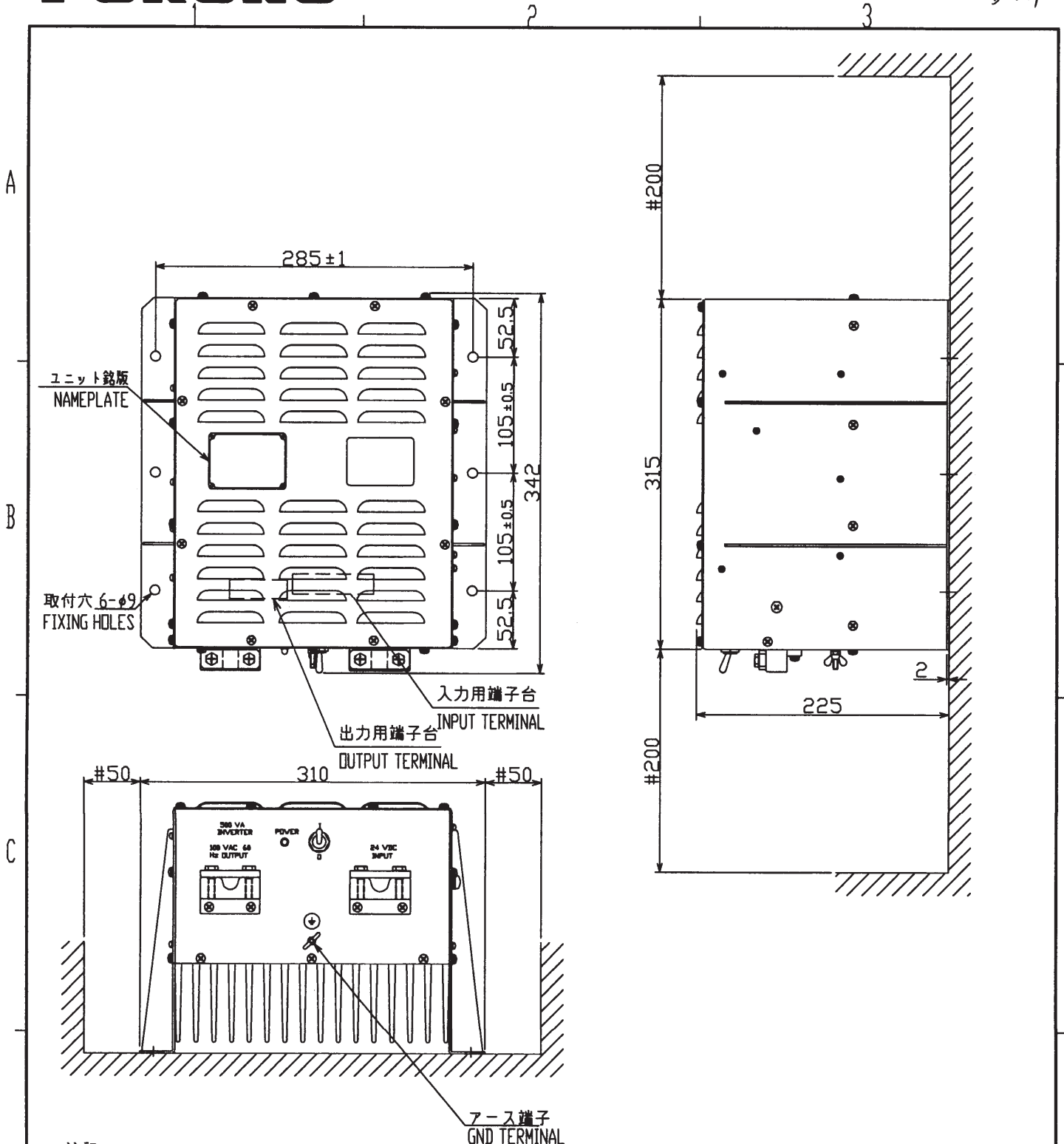
注記

- 1) 指定なき寸法公差は表1による。
- 2) #: 推奨するサービス空間寸法。
- 3) 取付けにはM8ボルトまたはコーチボルト呼び径8を使用のこと。

NOTE

1. TABLE 1 INDICATES TOLERANCE OF DIMENSIONS.
2. #: RECOMMENDED SERVICE CLEARANCE.
3. USE M8 BOLTS OR COARCH SCREWS $\phi 8$ FOR FIXING THE UNIT.

寸法区分(mm) DIMENSION	公差(mm) TOLERANCE
$0 < L \leq 50$	± 1.5
$50 < L \leq 100$	± 2.5
$100 < L \leq 500$	± 3

表1 TABLE1

DRAWN	Dec. 13 '02 T.YAMASAKI	TITLE	TR-2451
CHECKED	Dec. 16 '02 Y.KIMURA	名称	DC/ACインバータ
APPROVED	Dec. 16, '02 <i>Y. Kimura</i>		外寸図
SCALE	1/5	NAME	DC/AC INVERTER
	MASS 15 $\pm 10\%$ kg		OUTLINE DRAWING
DWG.No.	C1319-G04-B		

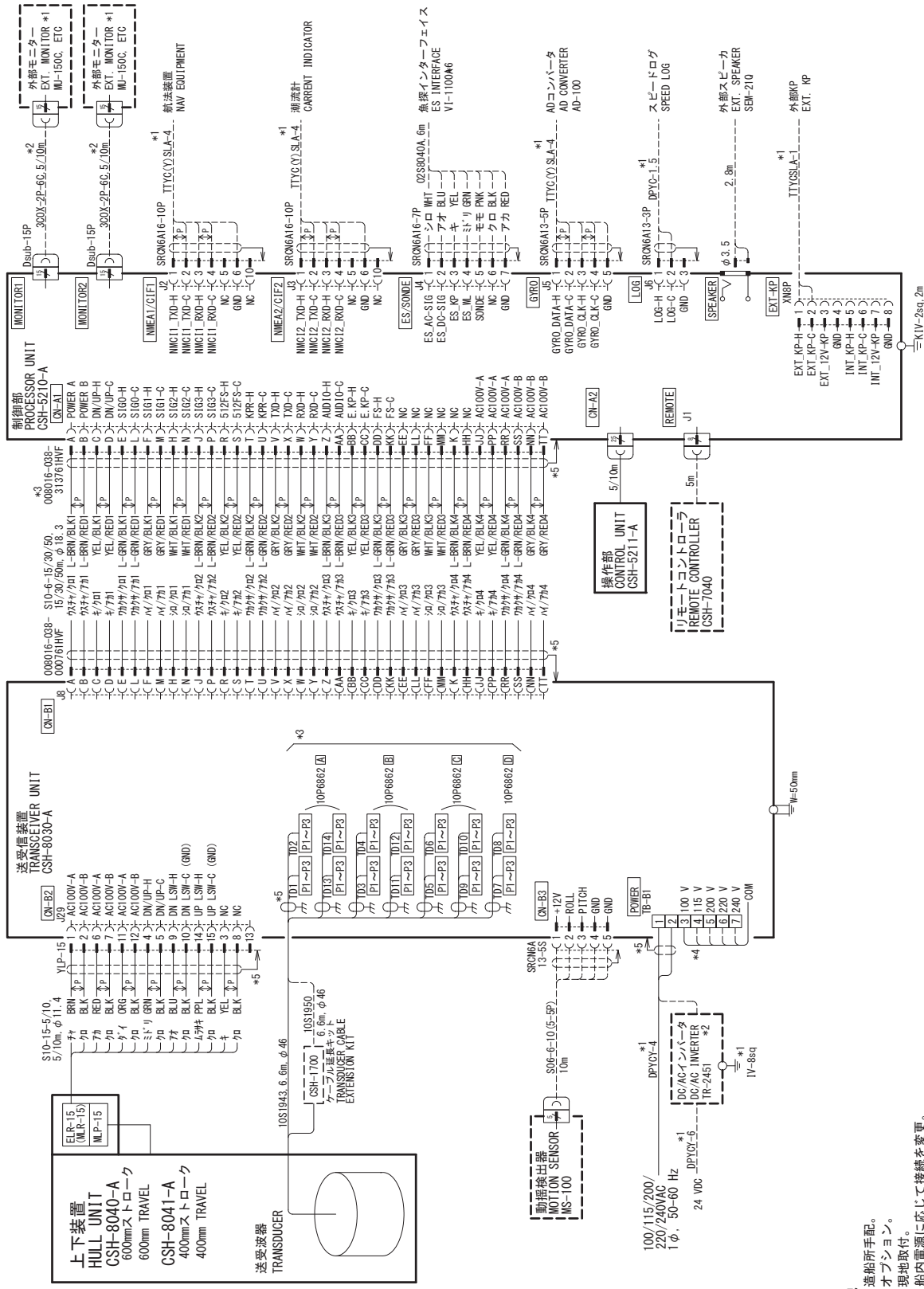

- 注記**
- 1) 造船所手配。
 - 2) オプション。
 - 3) 現地取付。
 - 4) 船内電源に応じて接続を変更。
 - 5) ケーブルランンプにて接地する。
 - 6) 魚探接続はリニアアンプ信号のみ可。
- NOTE**
- *1: SHIPYARD SUPPLY.
 - *2: OPTION.
 - *3: FITTED LOCALLY.
 - *4: CHANGE WIRE CONNECTION AS POWER SOURCE.
 - *5: GROUND THRU CABLE CLAMP.
 - *6: E/S CONNECTABLE BY LINEAR AMP SIGNAL ONLY.

DRAWN	7/Sep/2018	R. FUJIYAMA	TITLE	CSH-8L MARK-2
CHECKED	7/Sep/2018	T. YAMASAKI	名称	カラーエクスキャンニングソナー
APPROVED	7/Sep/2018	H. MAKI		相互接続図
SCALE	MASS	kg	NAME	COLOR SCANNING SONAR
DWG. No.	C1351-C01-B	REF. No.	10-078-1001-1	INTERCONNECTION DIAGRAM