

# **FURUNO**

## **OPERATOR'S MANUAL**

*BRIDGE NAVIGATIONAL WATCH  
ALARM SYSTEM (BNWAS)*

Model

**BR-500**

---

**ECF**

(Elemental Chlorine Free)

The paper used in this manual  
is elemental chlorine free.

**FURUNO ELECTRIC CO., LTD.**

9-52 Ashihara-cho,  
Nishinomiya, 662-8580, JAPAN

• FURUNO Authorized Distributor/Dealer

All rights reserved. Printed in Japan

Pub. No. OME-44610-J

(REFU ) BR-500

A : MAR. 2011

J : JUN. 06, 2022



0 0 0 1 7 4 6 1 8 1 8

# IMPORTANT NOTICES

---

## General

- This manual has been authored with simplified grammar, to meet the needs of international users.
- The operator of this equipment must read and follow the instructions in this manual. Wrong operation or maintenance can void the warranty or cause injury.
- Do not copy any part of this manual without written permission from FURUNO.
- If this manual is lost or worn, contact your dealer about replacement.
- The contents of this manual and the equipment specifications can change without notice.
- The example screens (or illustrations) shown in this manual can be different from the screens you see on your display. The screens you see depend on your system configuration and equipment settings.
- Save this manual for future reference.
- Any modification of the equipment (including software) by persons not authorized by FURUNO will void the warranty.
- The following concern acts as our importer in Europe, as defined in DECISION No 768/2008/EC.
  - Name: FURUNO EUROPE B.V.
  - Address: Siriusstraat 86, 5015 BT, Tilburg, The Netherlands
- The following concern acts as our importer in UK, as defined in SI 2016/1025 as amended SI 2019/470.
  - Name: FURUNO (UK) LTD.
  - Address: West Building Penner Road Havant Hampshire PO9 1QY, U.K.
- All brand, product names, trademarks, registered trademarks, and service marks belong to their respective holders.

## How to discard this product

Discard this product according to local regulations for the disposal of industrial waste. For disposal in the USA, see the homepage of the Electronics Industries Alliance (<http://www.eiae.org/>) for the correct method of disposal.

## How to discard a used battery

Some FURUNO products have a battery(ies). To see if your product has a battery, see the chapter on Maintenance. If a battery is used, tape the + and - terminals of the battery before disposal to prevent fire, heat generation caused by short circuit.

### In the European Union

The crossed-out trash can symbol indicates that all types of batteries must not be discarded in standard trash, or at a trash site. Take the used batteries to a battery collection site according to your national legislation and the Batteries Directive 2006/66/EU.

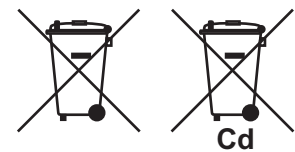

### In the USA

The Mobius loop symbol (three chasing arrows) indicates that Ni-Cd and lead-acid rechargeable batteries must be recycled. Take the used batteries to a battery collection site according to local laws.

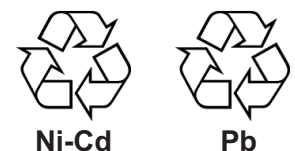



### In the other countries

There are no international standards for the battery recycle symbol. The number of symbols can increase when the other countries make their own recycle symbols in the future.











# SAFETY INSTRUCTIONS

Read these safety instructions before you operate or install the equipment.

 <b>WARNING</b>	Indicates a condition that can cause death or serious injury if not avoided.
 <b>CAUTION</b>	Indicates a condition that can cause minor or moderate injury if not avoided.

 Warning, Caution	 Prohibitive Action	 Mandatory Action
--	--	--

 <b>WARNING</b>	
	<b>Do not open the equipment.</b> This equipment uses high voltage that can cause electrical shock. Only qualified persons can work inside the equipment.
	<b>Turn off power at switchboard if the something is dropped inside the equipment.</b> Fire or electrical shock can result if the power remains on.
	<b>Turn off power at switchboard if the equipment is emitting smoke or fire.</b> Fire or electrical shock can result if the power remains on.

 <b>CAUTION</b>	
	<b>Do not disassemble or modify the equipment.</b> Fire, electrical shock or bodily injury can result.
	<b>Do not operate the equipment with wet hands.</b> Fire or electrical shock can result.
	<b>Keep the equipment away from rain, water and water splash.</b> Fire or electrical shock can result if water gets into the equipment.
	<b>Use the correct fuse.</b> Use of a wrong fuse can cause bodily injury or fire.

### Warning Label

A warning label is attached to the processor unit. Do not remove the label. If the label is missing or damaged, see your dealer about replacement.

 <b>WARNING</b> 
To avoid electrical shock, do not remove cover. No user-serviceable parts inside.
 <b>警告</b> 
感電の恐れあり。 サービスマン以外の方はカバーを開けないで下さい。内部には高電圧部分が数多くあり、万一さわると危険です。

Name: Warning Label (1)  
Type: 86-003-1011-3  
Code No.: 100-236-233-10



## WARNING



**Do not open the equipment unless authorized.**

This equipment uses high voltage which can cause electrical shock if mishandled.



**Turn off power at switchboard before starting the installation.**

Fire or electrical shock can result if the power is on.



**Be sure to connect to the correct power supply.**

Connection to a wrong power supply can cause fire or bodily injury.



**Do not disassemble or modify the equipment.**

Fire, electrical shock or bodily injury can result.

## CAUTION



**Securely ground (protection earth) the equipment.**

Ineffective ground can cause electrical shock.



**Follow the compass safe distances shown in the table below to prevent interference to a magnetic compass.**

Unit	Standard compass	Steering compass
BR-510	0.60 m	0.40 m
BR-520	2.70 m	1.75 m
BR-530	0.35 m	0.30 m
BR-540	0.60 m	0.40 m
BR-550	0.70 m	0.45 m
BR-560	0.55 m	0.35 m
BR-570	0.45 m	0.30 m

# TABLE OF CONTENTS

---

<b>FOREWORD</b> .....	<b>vi</b>
<b>SYSTEM CONFIGURATION</b> .....	<b>viii</b>
<b>1. MAIN ALARM PANEL</b> .....	<b>1-1</b>
1.1 Controls.....	1-1
1.2 How to Turn the System On/Off.....	1-1
1.3 BNWAS Display .....	1-2
1.4 How to Adjust the LCD/LED Brilliance, Key Backlighting.....	1-3
1.5 How to Assign Backup Officers.....	1-4
1.6 Mode .....	1-5
1.7 Dormant Period .....	1-5
1.8 Watch Alarm Sequence .....	1-5
1.9 Help Area .....	1-9
1.9.1 System failure indications .....	1-9
1.9.2 Active Alert list and Alert Log .....	1-11
1.9.3 Operational event indications.....	1-11
1.10 How to Make an Emergency Call.....	1-12
1.11 How to Call a Navigation Officer .....	1-13
1.12 External Emergency Call (Backup Navigator).....	1-13
<b>2. OPTIONAL EQUIPMENT</b> .....	<b>2-1</b>
2.1 Timer Reset Panel BR-530, BR-550.....	2-1
2.2 Cabin Panel BR-540 .....	2-2
2.3 Motion Detector BR-560.....	2-3
2.4 Flash Beacon BR-570 .....	2-4
<b>3. MAINTENANCE AND TROUBLESHOOTING</b> .....	<b>3-1</b>
3.1 Maintenance.....	3-1
3.2 Fuse Replacement.....	3-2
3.3 Troubleshooting .....	3-2
3.4 How to Check Connection Between Processor Unit/ Cabin Panel/ Timer Reset Panel.....	3-3
3.5 Life Expectancy of Major Parts .....	3-4
<b>4. INSTALLATION</b> .....	<b>4-1</b>
4.1 Equipment Lists.....	4-1
4.2 Mounting Considerations .....	4-2
4.3 Main Alarm Panel BR-510.....	4-3
4.3.1 Desktop mount.....	4-3
4.3.2 Flush mount .....	4-3
4.3.3 Shield film (option) .....	4-4
4.4 Processor Unit BR-520 .....	4-4
4.5 Timer Reset Panel BR-530, Cabin Panel BR-540, Motion Detector BR-560, Flash Beacon BR-570 (optional units) .....	4-4
4.5.1 Flush mount .....	4-4
4.5.2 Bulkhead mount (option).....	4-5
4.6 Watertight Timer Reset Panel BR-550 (option).....	4-9
4.7 Wiring.....	4-11
4.7.1 Processor Unit.....	4-11
4.7.2 Wiring information .....	4-13
4.7.3 Main Alarm Panel.....	4-14
4.7.4 Timer Reset Panel, Cabin Panel, Motion Detector, Flash Beacon .....	4-15

4.7.5	Flash Beacon .....	4-15
4.7.6	How to fabricate cables for the Cabin Panel, Timer Reset Panel, Flash Beacon and Motion Detector .....	4-16
4.8	DIP Switch, Rotary Switch Settings.....	4-16
4.9	How to Adjust LED Brilliance.....	4-17
4.10	Menu Settings.....	4-18
4.10.1	Administrator Menu .....	4-18
4.10.2	Service Menu .....	4-22
4.11	I/O Sentence Information.....	4-24
4.11.1	Input sentences .....	4-25
4.11.2	Output sentences .....	4-26
<b>APPX. 1 MENU TREE, ABBREVIATIONS, JIS CABLE GUIDE .....</b>		<b>AP-1</b>
<b>APPX. 2 ALERT ICONS, IDS, MEANINGS AND MEASURES .....</b>		<b>AP-3</b>
<b>SPECIFICATIONS .....</b>		<b>SP-1</b>
<b>PACKING LISTS .....</b>		<b>A-1</b>
<b>OUTLINE DRAWINGS .....</b>		<b>D-1</b>
<b>INTERCONNECTION DIAGRAM .....</b>		<b>S-1</b>
<b>INDEX .....</b>		<b>IN-1</b>

# FOREWORD

---

## A Word to the Owner of the BR-500

Congratulations on your choice of the FURUNO BR-500 Bridge Navigational Watch Alarm System (BNWAS). We are confident you will see why the FURUNO name has become synonymous with quality and reliability.

Since 1948, FURUNO Electric Company has enjoyed an enviable reputation for innovative and dependable marine electronics equipment. This dedication to excellence is furthered by our extensive global network of agents and dealers.

Your equipment is designed and constructed to meet the rigorous demands of the marine environment. However, no machine can perform its intended function unless properly operated and maintained. Please carefully read and follow the operation and maintenance procedures set forth in this manual.

Thank you for considering and purchasing FURUNO.

We would appreciate feedback from you, the end-user, about whether we are achieving our purposes.

## Features

The BR-500 monitors the Officer of the Watch's (OOW) presence on the bridge to prevent maritime casualties. The system sends an alarm to the quarters of the backup officer if the OOW fails to respond to the active alarm or emergency call.

- Complies to the following standards;  
IMO MSC.128 (75), IEC60945 Ed.4, IEC61162-1 Ed.5 (2016-08), IEC62923-1/2 Ed.1.
- Watches for unattended bridge and operator disability.
- Transmits alarm to backup officer if the OOW fails to respond to active alarm or emergency call.
- Motion Detector (option) detects motion on the bridge to confirm operator fitness.
- Flash Beacon (option) flashes to remind OOW to confirm presence (by operating equipment in the system).

## Software history

Main Alarm Panel Program	Processor Unit Program
<ul style="list-style-type: none"><li>• BOOT: 2450054-01.xx Initial version 04/2015</li><li>• APPLICATION: 2450056-02.xx</li></ul>	<ul style="list-style-type: none"><li>• BOOT: 2450058-01.xx Initial version 04/2015</li><li>• APPLICATION: 2450060-02.xx</li><li>• CPLD: 2450065-01.xx</li></ul>

xx: denotes minor change to version number.

## CE declaration

With regards to CE declarations, please refer to our website ([www.furuno.com](http://www.furuno.com)) for further information about RoHS conformity declarations.

## **Disclosure of Information about China RoHS**

With regards to China RoHS information for our products, please refer to our website ([www.furuno.com](http://www.furuno.com)).

## **Usage precautions**

### **Back-up power supply**

The BR-500 is not equipped with a back-up power supply. Use an external back-up power supply (24 VDC) when the main or auxiliary power fails.

### **Motion Detector (BR-560)**

- The Motion Detector judges motion by the amount of temperature change within the detection area. If the area has source(s) of heat other than personnel or the temperature change is too small, detection of motion may not be possible. Keep the following points in mind:

#### **Motion is mis-detected when**

- movement in sleep is judged as motion.
- movement by small animal(s) is judged as motion.
- equipment that circulates air (air conditioner, etc.), steam-generating warmers and the like causes temperature change.
- sunlight or shade in the detection area causes temperature change.

#### **Motion cannot be detected if**

- The ambient temperature is almost the same as personnels'.
  - the temperature change in personnel or detection area is too small.
  - personnel motion is too fast or too slow
  - there is an obstruction between personnel and the Motion Detector.
- The Motion Detector can be affected by sunlight. Install it in a place well away from sunlight.

**Note:** The surrounding environment can prevent detection of movement, thus the motion detector can only act as an aid to the timer reset panel. FURUNO will accept no responsibility for any accidents resulting from sensor misdetection.

### **Resetting the watch alarm timer**

Reset the watch alarm timer from the Timer Reset Panel, which is installed next to the Main Alarm Panel.

# SYSTEM CONFIGURATION

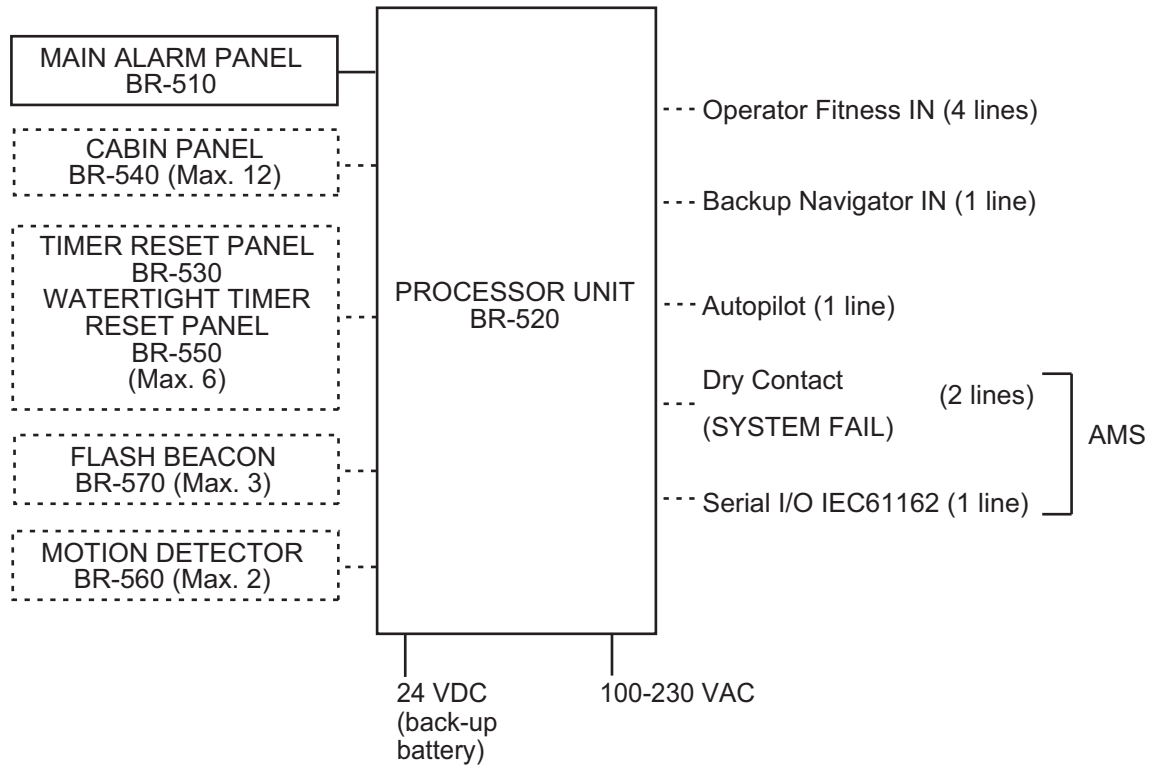

- Dashed lines indicate optional or local supply equipment.
- Environmental category:  
 Units protected from the weather: BR-510, BR-520, BR-530, BR-540, BR-560, BR-570  
 Units exposed to the weather: BR-550

# 1. MAIN ALARM PANEL

The Main Alarm Panel is the heart of the BNWAS. All settings are done from the Main Alarm Panel.

## 1.1 Controls



**How to detach the hard cover from the unit**

Put your thumbs on the front and forefingers on the catches at the sides of the cover. Pull the cover toward you.

No.	Control Name	Description
1	SEL	<b>Press:</b> Select the backup officer. <b>Long press:</b> Select the regular backup officer.
2	MODE	Select the operating mode.
3	MENU/ESC	Open the menu; return to previous setting or previous screen. <b>Long press:</b> Displays the Active Alert list and Alert Log.
4	CursorPad	Select items on menus; adjust LCD brilliance and key backlighting.
5	ENT/CALL	Confirm operation; call the Captain or other navigation officer.
6	EMG	Make emergency call.
7	RESET	Reset the watch timer.

## 1.2 How to Turn the System On/Off

Power to the system is supplied from the power switch on the ship's switchboard. After the power is applied to the system, the BNWAS display, shown to the right, appears.

**Note:** Wait at least one minute before reapplying the power to ensure correct startup.

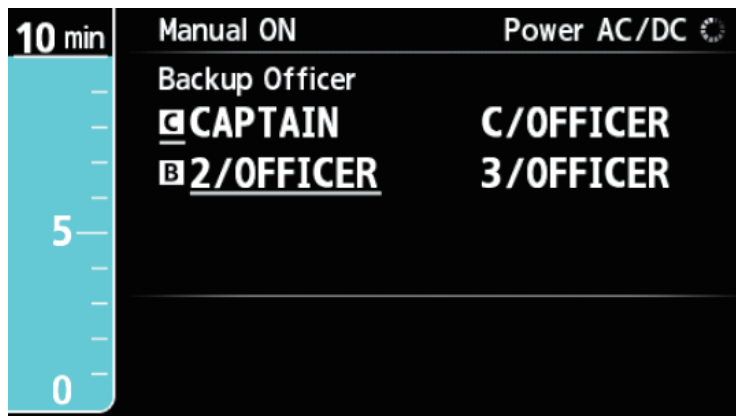

## 1.3 BNWAS Display

The BNWAS display is divided into the seven areas described below.

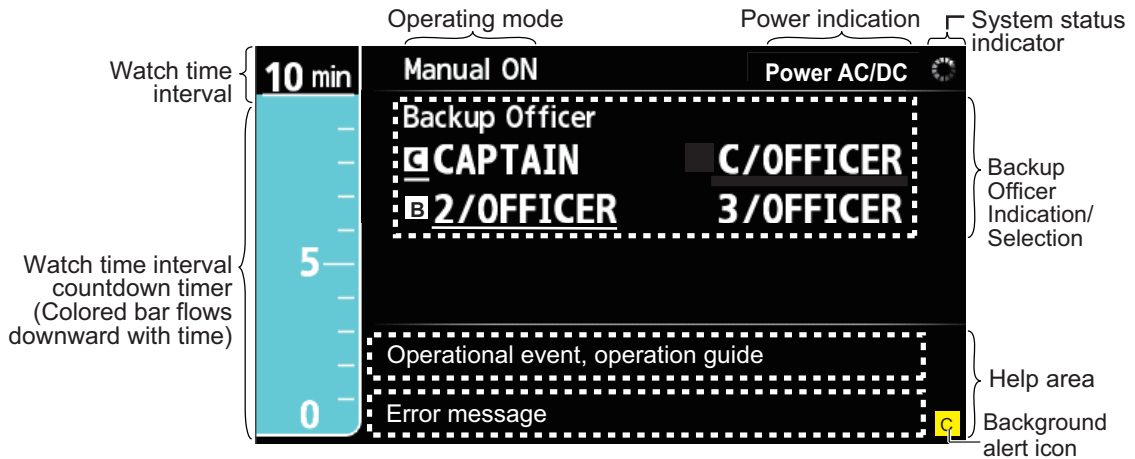

### Operating mode

The current operating mode. The possible indications are Auto, Manual ON, and Manual OFF.

**Note:** Auto operating mode is not available for SOLAS vessels.

### Power indication

The power indications shows the power being supplied to the system.

- Power AC/DC: Both AC and DC power
- Power AC: AC power
- Power DC: DC power

If something appears to be wrong with the system, check the power source (battery) and cables.

### System status indicator

The system status indicator rotates when the system is normal, and appears on all displays. If the indicator is not rotating, there can be a problem with the system. Contact a FURUNO agent or dealer for information.

### Backup officer indication/selection

Up to six backup officers can be assigned using the **SEL** key. The current assigned backup officers are displayed with a backup icon ( **B** ) before their name, as shown for C/OFFICER in the above figure. When [Captain Backup] is set to [ON], the captain icon ( **C** ) is underlined, as shown in the above figure.

### Help area

The help area shows all operational events, operation guides and error messages. See section 1.9 "Help Area".



**Background alert icon**

When more than one alert is active, alerts other than the latest alert with the highest priority are shown as “background alert icon” in the help area. The background alert icon reflects the priority of alert as follows:

- Yellow-orange circle with “W”: Warning level
- Yellow square with “C”: Caution level

**Watch time interval countdown timer**

The length of the bar decreases as time progresses and the color of the bar changes with each stage.

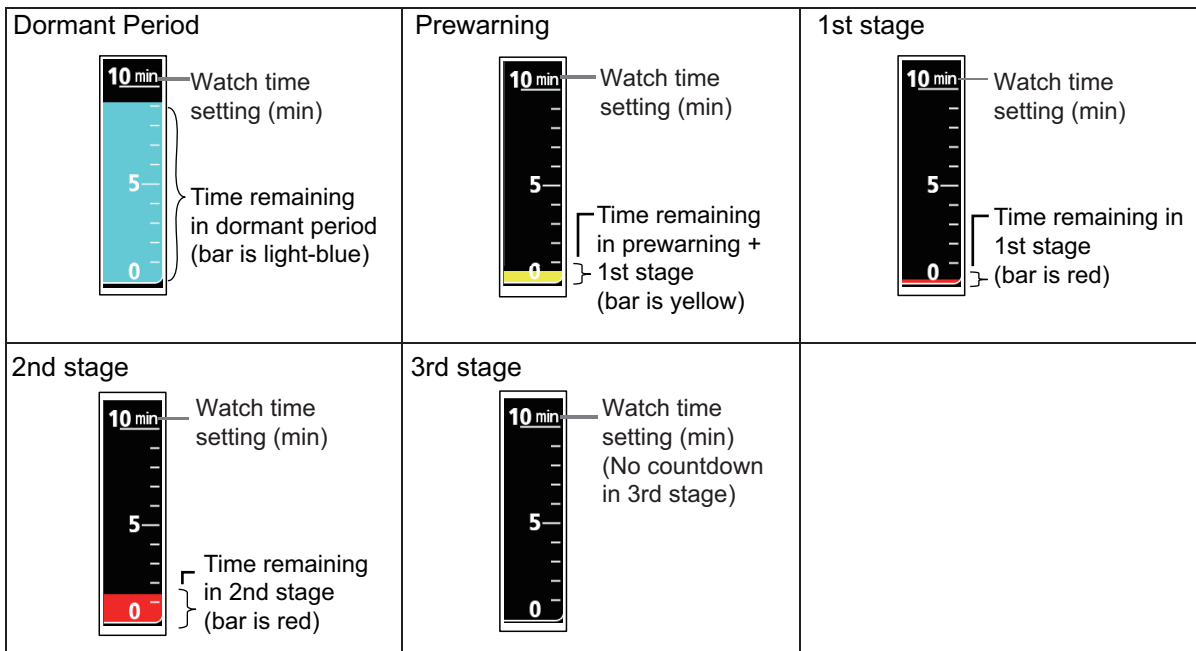

**Watch time interval setting**

The currently selected watch time interval appears at the top of the watch time interval countdown timer.

**1.4 How to Adjust the LCD/LED Brilliance, Key Backlighting**

The brilliance of the LCD of the Main Alarm Panel, the ALARM LED of the Timer Reset Panel and the LED of the Flash Beacon, and the backlighting for the keys of the Main Alarm Panel can be adjusted as shown below.

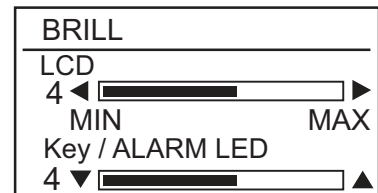

1. Press any arrow on the CursorPad to show the [BRILL] window.
2. Press the right or left arrow on the CursorPad to adjust the brilliance of the LED. The setting range is 0-7, and the default setting is 5.
3. Press the up or down arrow on the CursorPad to adjust the key backlighting of the Main Alarm Panel and the ALARM LEDs (incl. Flash Beacon). The setting range is 0-7, and the default setting is 5.

## 1. MAIN ALARM PANEL

4. Press the **MENU/ESC** key to close the window. (The window closes automatically if there is no adjustment within several seconds.)

**Note 1:** If the screen is too bright with minimum brilliance at nighttime, install the shield film (option) to reduce the brilliance. See subsection 4.3.3.

**Note 2:** The system increases the brilliance one step in stages 1-3 of the watch alarm. When the timer is reset, the previous brilliance is restored. Brilliance is not changed if it is set for maximum at stages 1-3.

## 1.5 How to Assign Backup Officers

You can assign up to six backup officers and select the backup officer on duty from the BNWAS display.

### How to assign one officer as backup

Press the **SEL** key to move the underline cursor and assign a backup officer. The underline cursor moves with each press of the **SEL** key.

In the example figure below, [C/OFFICER] is assigned as the backup officer.

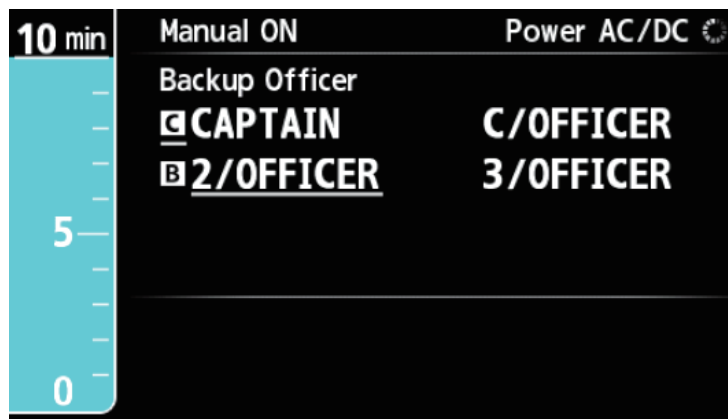

The backup officer also has a backup icon ( **B** ) to the left of their name, as shown in the figure above.

### How to assign multiple officers as backup

1. Press the **SEL** key to select the first officer to assign as backup.
2. Press and hold the **SEL** key to show an underline below the selected officer's backup icon. This officer is now saved as a backup officer.

- Repeat steps 1 and 2 to assign other backup officers as required.

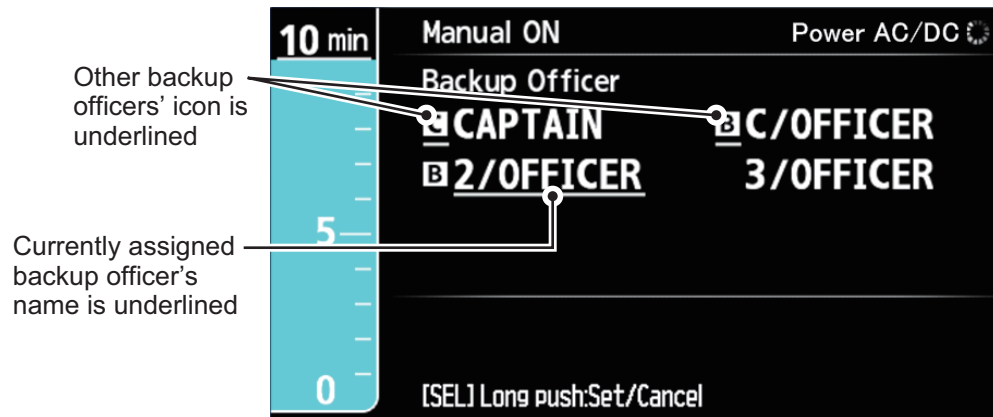

- To cancel a backup officer assigned in this manner, select the officer, then press and hold the **SEL** key. The underline indication below the backup icon disappears. You can now select a different officer to assign as backup.

## 1.6 Mode

The BR-500 has three main modes of operation:

**Manual OFF:** The BNWAS is inactive. Use this mode when entering or just leaving harbor. No reset is necessary. Default setting.

**Manual ON:** The BNWAS is active. Use this mode when the vessel is traveling on the open sea. Reset is necessary to continue operation.

**AUTO:** The BNWAS is active or inactive according to the autopilot state. BNWAS is ON when the autopilot is ON; OFF when the autopilot is OFF.

**Note:** Auto operating mode is not available for SOLAS vessels.

- Press the **MODE** key. You are asked to enter the password. Enter the password. See the FURUNO service technician for the password.
- Use the CursorPad to select a mode then press the **ENT/ CALL** key.

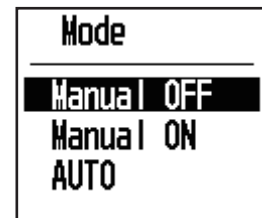

## 1.7 Dormant Period

The watch time interval can be selected from the Administrator Menu. Only the administrator of the system can access the Administrator Menu. See subsection 4.10.1 menu for how to select the interval time.

## 1.8 Watch Alarm Sequence

The watch alarm checks for the presence of the OOW on the bridge. If equipment on the bridge (Main Alarm Panel, Timer Reset Panel, Backup Navigator, Autopilot, or Motion Detector) is operated within the selected watch time interval, no alarm is given. If no equipment is operated within the selected watch time interval, the system continues in the sequence shown below.

1. MAIN ALARM PANEL

1. The watch alarm timer starts when the system is started. The length of the watch time interval countdown timer bar (color is light-blue at this time) decreases as time progresses. (The timer interval is set on the Administrator Menu, which is under the control of the Administrator.)

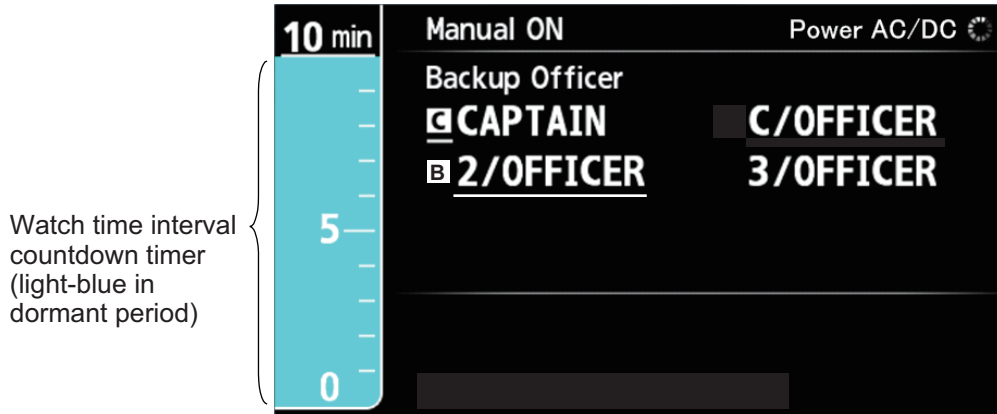

If the equipment connected to the system is operated before the timer reaches zero, the timer countdown is restarted.

2. If the equipment connected to the system is not operated within the watch time interval, the PREWARNING phase begins:



- Main Alarm Panel shows a 15-second visual alarm (in yellow)
- Timer Reset Panel flashes its ALARM LED for 15 seconds
- Flash Beacon flashes

3. If the equipment connected to the system is not operated during the PREWARNING, the 1st stage visual and audible alarms begin.

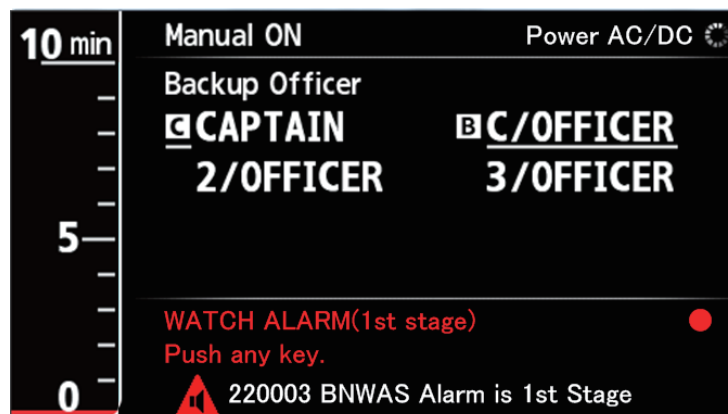

- Main Alarm Panel releases a 15-second visual (in red) and audible alarms
- Timer Reset Panel flashes its ALARM LED for 15 seconds and sounds its buzzer for 15 seconds
- Flash Beacon flashes

4. If the equipment connected to the system is not operated within 15 seconds, the 2nd stage visual and audible alarms begin.

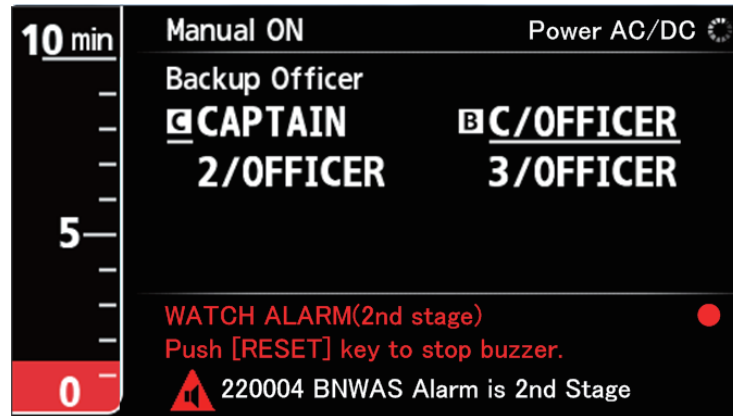

- Main Alarm Panel shows a 90-180-second visual alarm (in red) and sounds its buzzer for 90-180 seconds
- Timer Reset Panel flashes its ALARM LED for 90-180 seconds and sounds its buzzer for 90-180 seconds
- Cabin Panel:
  - Captain selected as a backup officer: ALARM LED lights and buzzer sounds, 90-180 seconds each
  - Backup officer (selected on BNWAS display): ALARM LED lights and buzzer sounds, 90-180 seconds each
  - Other backup officer: No action
  - Public cabin: ALARM LED lights and buzzer sounds, 90-180 seconds each
- Flash Beacon flashes or is OFF (depending on DIP SW setting)

**Note:** The alarm cannot be stopped from a Timer Reset Panel at this point.

5. If, within the 2nd stage watch interval (90-180 seconds), the equipment connected to the system is not operated or the OOW does not press the **RESET** key, the 3rd stage visual and audible alarms begin.

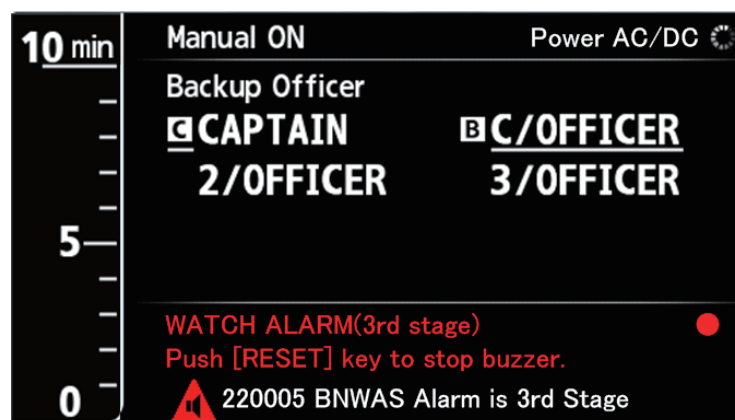

1. MAIN ALARM PANEL

- Main Alarm Panel continuously displays a visual alarm (in red) and sounds its buzzer until reset occurs
- Timer Reset Panel continuously flashes its ALARM LED and sounds its buzzer until reset occurs
- All Cabin Panels continuously light their ALARM LEDs and sound their buzzers until reset occurs
- Flash Beacon flashes or is OFF (depending on DIP SW setting)

6. At the 2nd and 3rd stages, stop the buzzer and acknowledge the alarm with the **RESET** key on the Main Alarm Panel.

Equipment and visual alarm, LED, buzzer

Equipment	State	LED color	Dormant Period	Pre-warning	1st stage	2nd stage* <sup>2</sup>	3rd stage
Main Alarm Panel BR-510	Visual alarm		None	Yes	Yes	Yes	Yes
	Buzzer		None	None	Yes	Yes	Yes
Timer Reset Panel BR-530/550	RESET LED	Green	Lit	Lit	Lit	Lit	Lit
	ALARM LED	Yellow	OFF	Flashing	Flashing	Flashing	Flashing
	Buzzer		None	None	Yes	Yes	Yes
Cabin Panel: BR-540 Captain* <sup>1</sup>	DUTY LED	Green	Lit* <sup>3</sup>	Lit* <sup>3</sup>	Lit* <sup>3</sup>	Lit* <sup>3</sup>	Lit* <sup>3</sup>
	ALARM LED	Red	OFF	OFF	OFF	Lit* <sup>3</sup>	Lit
	Buzzer		None	None	None	Yes* <sup>3</sup>	Yes
Cabin Panel BR-540: Backup officer* <sup>5</sup>	DUTY LED	Green	Lit	Lit	Lit	Lit	Lit
	ALARM LED	Red	OFF	OFF	OFF	Lit	Lit
	Buzzer		None	None	None	Yes	Yes
Cabin Panel BR-540: other officers	DUTY LED	Green	OFF	OFF	OFF	OFF	OFF
	ALARM LED	Red	OFF	OFF	OFF	OFF	Lit
	Buzzer		None	None	None	None	Yes
Cabin Panel BR-540: public cabin	DUTY LED	Green	OFF* <sup>6</sup>	OFF* <sup>6</sup>	OFF* <sup>6</sup>	OFF* <sup>6</sup>	OFF* <sup>6</sup>
	ALARM LED	Red	OFF	OFF	OFF	OFF* <sup>6</sup>	Lit
	Buzzer		None	None	None	None* <sup>6</sup>	Yes
Flash Beacon BR-570	LED	Yellow	OFF	Flashing	Flashing	Flashing* <sup>4</sup>	Flashing* <sup>4</sup>

\*1 Captain selected as backup officer on Administrator menu.

\*2 Output if [2nd Stage] is set to ON in Administrator menu.

\*3 [Captain Backup] set to ON in Administrator menu.

\*4 According to DIP SW setting in Processor Unit; SW ON: OFF, SW OFF: Flashes.

\*5 Officer selected as a backup officer.

\*6 According to DIP SW setting in Processor Unit;  
SW ON: Sending alarm at 2nd stage.  
SW OFF: Not sending alarm at 2nd stage.

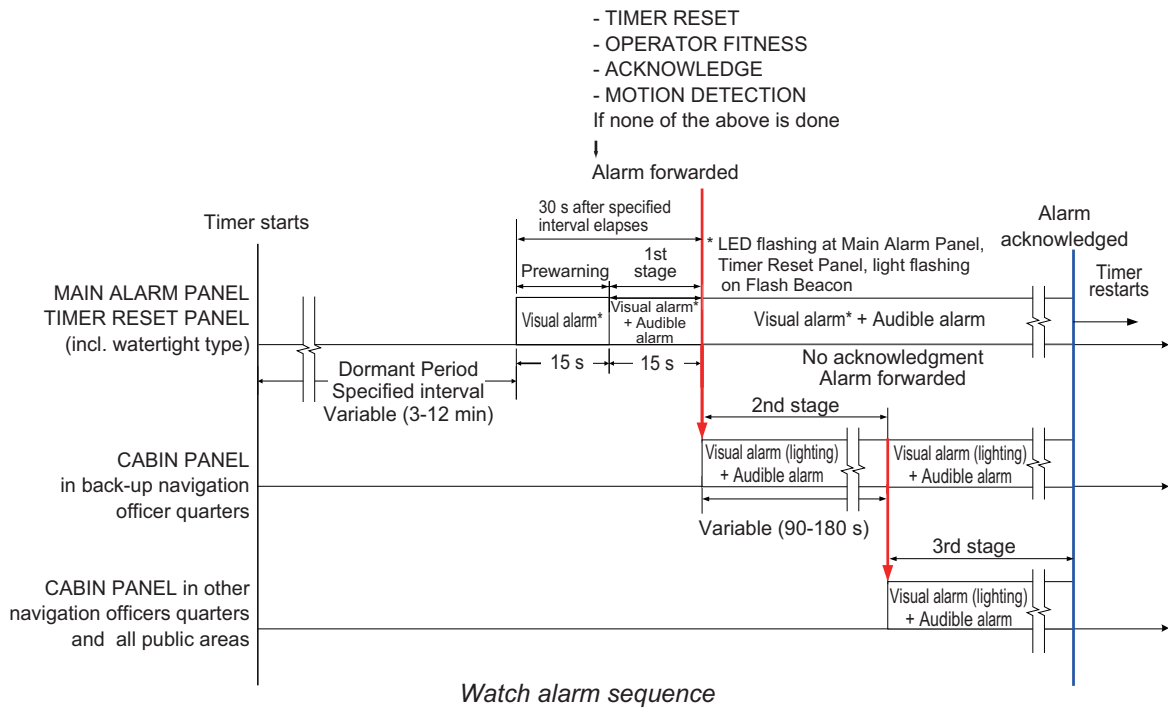

## 1.9 Help Area

The help area displays alerts related to system failures, operational events, operation help, etc.

### 1.9.1 System failure indications

This section describes how system failures are given and the accompanying operation flow.

1. The help area shows system failure messages in white (warning level alerts have a flashing yellow background, alarm level alerts have a red flashing background), along with the respective alert number and icon. The alert number differs depending on the Alarm Mode chosen at installation. To change the Alarm Mode settings, consult a FURUNO technician. Only the alert with the highest priority is displayed in the help area. All other alerts are listed on the [Active Alert] list and [Alert Log] screens. (See subsection 1.9.2.)
2. The buzzer at the Main Alarm Panel sounds.
3. Press any key on the Main Alarm Panel to stop the buzzer and acknowledge the alarm.
4. For any system error, contact a FURUNO sales representative or service technician for advice.

The tables below show the alert messages, along with their respective alert icon and alert number, in order of priority.

1. MAIN ALARM PANEL

Legacy Mode

Alert ID & Indication	Problem	Measures
010 Failure: Communication	Communication failure between Processor Unit and Main Alarm Panel	Consult a FURUNO technician.
011 Failure: AC	AC power to the unit is interrupted or stopped.	Check power to the unit, check cabling and connections to the unit.
012 Failure: DC	DC power to the unit is interrupted or stopped.	Check power to the unit, check cabling and connections to the unit.

Alert I/F1 Mode

Alert ID & Indication	Problem	Measures
250 Communication Failure	Communication failure between Processor Unit and Main Alarm Panel.	Consult a FURUNO technician.
001 DC Power Failure	DC power to the unit is interrupted or stopped.	Check power to the unit, check cabling and connections to the unit.
002 AC Power Failure	AC power to the unit is interrupted or stopped.	Check power to the unit, check cabling and connections to the unit.

Alert I/F2 Mode

Alert ID & Indication	Problem	Measures
3062 Communication Failure	Communication failure between Processor Unit and Main Alarm Panel.	Consult a FURUNO technician.
3023-1 DC Power Failure	DC power to the unit is interrupted or stopped.	Check power to the unit, check cabling and connections to the unit.
3023-2 AC Power Failure	AC power to the unit is interrupted or stopped.	Check power to the unit, check cabling and connections to the unit.
3031-1 BNWAS Alarm is 1st Stage	Watch alarm is at first stage	Press any key on the Main Alarm Panel, or press the Timer Reset Panel button.
3031-2 BNWAS Alarm is 2nd Stage	Watch alarm is at second stage	Press the <b>RESET</b> key on the Main Alarm Panel.
3031-3 BNWAS Alarm is 3rd Stage	Watch alarm is at third stage	Press the <b>RESET</b> key on the Main Alarm Panel.

For a full list of alert icons, alert IDs, priorities, categories and suggested measures, see "ALERT ICONS, IDS, MEANINGS AND MEASURES" on page AP-3.



## 1.9.2 Active Alert list and Alert Log

All active alerts are listed on the [Active Alert] list. To open the list, do the following:

1. Press and hold the **MENU/ESC** to display the [Active Alert] list.

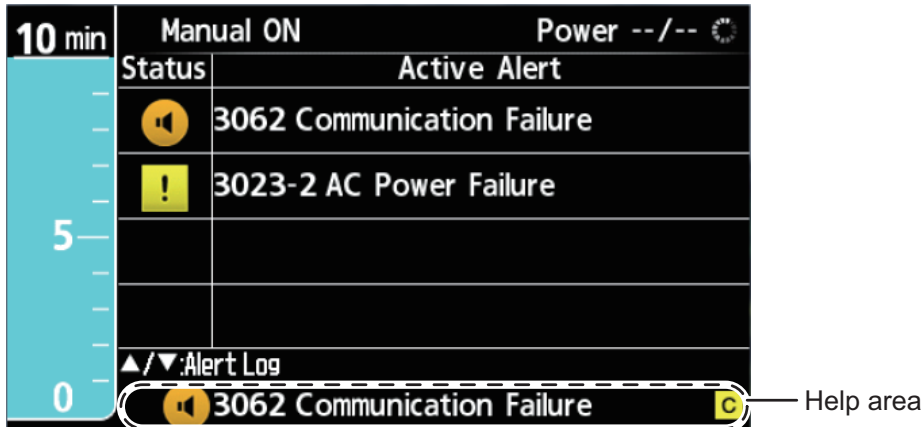

*Active Alert list*

2. Press or to change between the [Active Alert] list and [Alert Log].

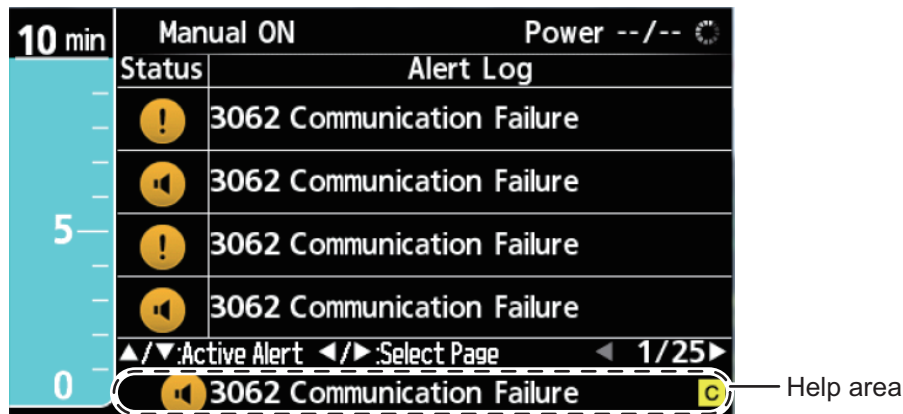

*Alert Log*

3. Press or to change pages on the Alert Log.
4. To close the [Active Alert] list and [Alert Log], press the **MENU/ESC** key.

**Note 1:** The [Alert Log] and [Active Alert] list are not available when there is a BNWAS alert active. If a BNWAS alert is activated while the [Alert Log] or [Active Alert] list are open, the menu is closed and the BNWAS display is restored.

**Note 2:** The help area at the bottom of the [Active Alert] list and [Alert Log] displays the highest priority alert (currently active alert). If there is no active alert, this area displays operational guidance.

## 1.9.3 Operational event indications

When an operational event occurs, the Main Alarm Panel shows the related message in red, yellow or white in the help area.

Indication	Event	Color
MANUAL OFF	Manual Off mode selected.	White
Autopilot OFF	Auto mode selected, Autopilot signal off.	White

1. MAIN ALARM PANEL

Indication	Event	Color
PREWARNING WATCH ALARM Push any key.	Presence on bridge* not confirmed in dormant period.	Yellow
WATCH ALARM (1st Stage) Push any key.	Presence on bridge* not confirmed at prewarning phase.	Red
WATCH ALARM (2nd Stage) Push [RESET] key to stop buzzer.	Presence on bridge* not confirmed at 1st stage.	Red
WATCH ALARM (3rd Stage) Push [RESET] key to stop buzzer.	Presence on bridge* not confirmed at 2nd stage.	Red
WATCH ALARM (2nd Stage: Emergency Call) Push [RESET] key to stop buzzer.	Emergency call made from Main Alarm Panel.	Red
WATCH ALARM (3rd Stage: Emergency Call) Push [RESET] key to stop buzzer.	Emergency call made from Main Alarm Panel.	Red
2nd Stage: External Emergency Call Activated	Backup navigator signal received	Red
3rd Stage: External Emergency Call Activated	Backup navigator signal received	Red

\* **RESET** key not pressed or equipment on bridge is not operated.

## 1.10 How to Make an Emergency Call

The purpose of an emergency call is to immediately start the watch timer from the 2nd stage. (This feature is disabled if the watch alarm is already in the 2nd or 3rd stage.)

Press the **EMG** key to start the emergency call.

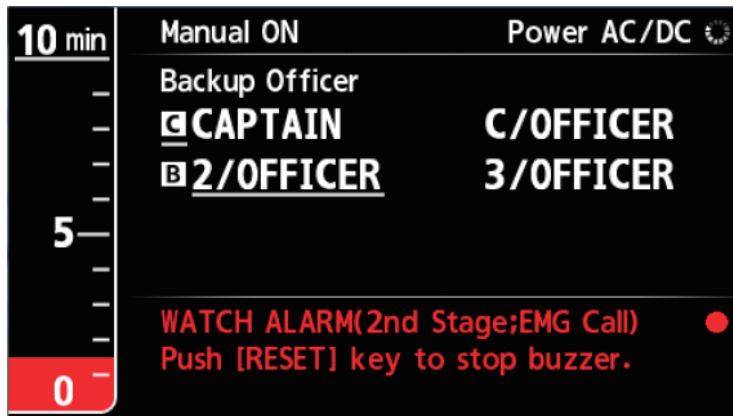

The system goes into the 2nd stage (or 3rd stage depending on system setting). In the 2nd stage, the following occurs:

- Main Alarm Panel presents a visual alarm and sounds its buzzer.
- Timer Reset Panel flashes its ALARM LED and sounds its buzzer.
- Cabin Panel:
  - Captain’s room: ALARM LED lights and buzzer sounds.
  - Backup officer (selected on BNWAS display): ALARM LED lights and buzzer sounds.
  - Other backup officer: No action
  - Public cabin: ALARM LED lights and buzzer sounds.
- Flash Beacon flashes or is OFF (depending on DIP SW setting).

If the visual and audible alarms are not cancelled at the 2nd stage, the system goes to the 3rd stage and all visual and audible alarms are generated.

To stop the buzzer or cancel the emergency call, press the **RESET** key on the Main Alarm Panel. The system returns to the dormant state.

## 1.11 How to Call a Navigation Officer

The OOW can call the Cabin Panel of the back-up officer. Use the call feature when it is necessary to call a navigation officer to the bridge. This feature is available in all modes. When the watch alarm is generated during a call, the call is cancelled to process the alarm.

The ALARM LED on the called Cabin Panel lights (red) and the Cabin Panel's buzzer sounds.

To call a navigation officer do the following.

1. Press the **ENT/CALL** key to show the following window.
2. Use the CursorPad to select the navigation officer to call.
3. Press the **ENT/CALL** key to start the call. The called Cabin Panel's ALARM LED lights and the panel's buzzer sounds.
4. To stop the call, press the **ENT/CALL** key again.

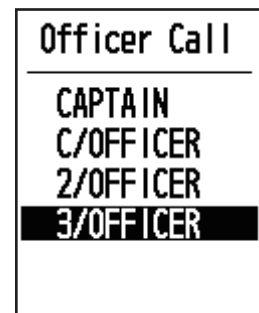

## 1.12 External Emergency Call (Backup Navigator)

The Main Alarm Panel can receive external emergency calling from external equipment, by setting Input Port 2 to Backup Navigator on the Service menu. When this function is active, the Main Alarm Panel shows "External Emergency Call" and the system goes into the 2nd stage. Neither visual nor audible alarms are released from the Main Alarm Panel, Timer Reset Panel or Flash Beacon. The audible alarm sounds at the Backup Officer's Cabin Panel. After the system goes to the 3rd stage, the Main Alarm Panel, Timer Reset Panel and Flash Beacon do not generate visual or audible alarms; but, every Cabin Panel sounds the audible alarm.

**To stop the buzzer or cancel the emergency call, deactivate the external emergency calling. The system cannot stop the buzzer or cancel the call with the [Reset] key on the Main Panel or Timer Reset Panel.**

The emergency alarm is also generated when the connection between an external equipment and input port 2 is disconnected. Check the connection between the Main Alarm Panel and the external equipment, even if the external equipment does not generate an alarm.

1. MAIN ALARM PANEL

This page is intentionally left blank.

## 2. OPTIONAL EQUIPMENT

### 2.1 Timer Reset Panel BR-530, BR-550

The Timer Reset Panel BR-530 is installed on the bridge, and the Watertight Timer Reset Panel BR-550 is installed on the wing when it is necessary to have a unit there. A total of six Timer Reset Panels can be installed.

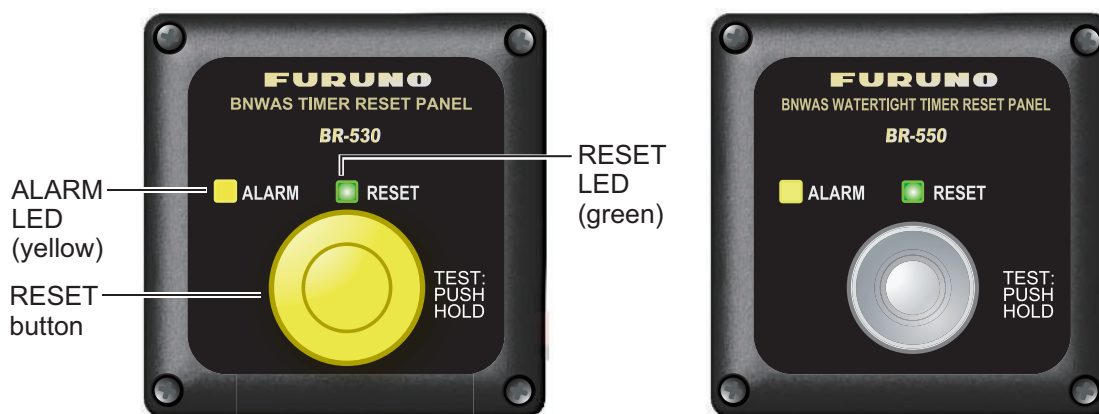

TIMER RESET PANEL BR-530

WATERTIGHT TIMER RESET PANEL BR-550

If the **RESET** button is pressed within the selected watch time interval, the watch timer is reset. If operation on the bridge is not confirmed within the time interval, the **ALARM** LED flashes (in yellow) every second for 15 seconds after the selected time interval ends. The **ALARM** LED flashes an additional 15 seconds after the **PREWARNING** phase ends, accompanied by a 15-second audible alarm. Reset can be done at the **PREWARNING** and 1st stage.

You can reset the watch alarm at the 1st stage (before the alarm is sent to the next stage) with the **RESET** button on the Timer Reset Panel. If the alarm is sent to the 2nd or 3rd stage, the alarm cannot be stopped from the Timer Reset Panel. To acknowledge the alarm from the 2nd or 3rd stage, use the **RESET** key on the Main Alarm Panel.

The **RESET** LED lights (in green) continuously when the unit is powered. The brilliance of **ALARM** LED is adjusted from the CursorPad of Main Alarm Panel (linked by key backlight).

**Note 1:** Press the **RESET** button with a touch-and-release action to reset the watch timer. The watch timer is not reset if the button is pressed and held.

**Note 2:** When the **RESET** button is pressed and held, the connection between the Processor Unit and Timer Reset Panel is checked. The buzzer sounds when the test is started. See section 3.4.

## 2.2 Cabin Panel BR-540

The Cabin Panel is installed in all navigation officers' quarters and in public areas. The Cabin Panel releases audible and visual alarms if the OOW did not confirm presence on the bridge within the selected watch time interval. A total of 12 Cabin Panels can be installed.

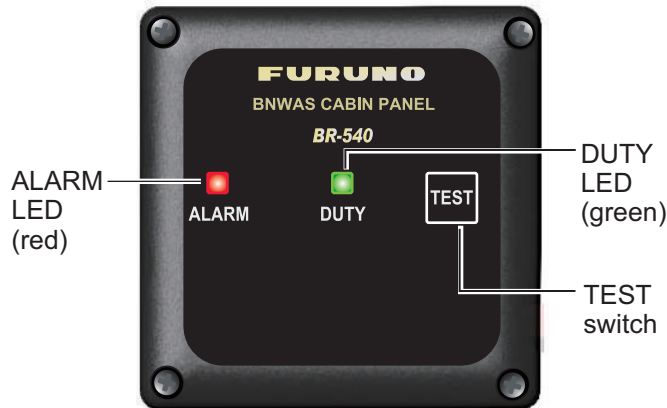

CABIN PANEL BR-540

### **DUTY LED**

The DUTY LED is illuminated (in green) when the BNWAS is active and according to type of Cabin Panel:

- Cabin Panel set as Captain, Backup Officer or Public is illuminated in all phases of the watch alarm.

**Note:** The LED is disabled when a 4-core cable (MPYC-4 or equivalent) connects Cabin Panel(s) to the Processor Unit.

### **ALARM LED**

The ALARM LED lights (in red) and the buzzer sounds in response to an alarm sent to the 2nd and 3rd stages.

### **TEST switch**

The **TEST** switch checks the LEDs and the buzzer for correct operation. The connection between the Cabin Panel and Processor Unit is also checked. (This check is not available when those units are connected to each other with a 4-core cable.) See section 3.4.

## 2.3 Motion Detector BR-560

The Motion Detector BR-560 detects motion on the bridge. The maximum motion detection range is 5 m.

The “motion” signal is output via the Processor Unit to tell the Main Alarm Panel to reset the watch alarm.



MOTION DETECTOR BR-560

## 2.4 Flash Beacon BR-570



The Flash Beacon BR-570 flashes at the Prewarning phase and the 1st stage. It either flashes or is OFF at the 2nd and 3rd stages depending on the setting of segment #4 of DIP SW S1. (See section 4.8.) The brilliance of LED is adjusted from the CursorPad of Main Alarm Panel (linked by key backlight).





# 3. MAINTENANCE AND TROUBLESHOOTING

This chapter provides maintenance and troubleshooting procedures for the user and serviceman.

 <b>WARNING</b>	 <p><b>ELECTRICAL SHOCK HAZARD</b> Do not open the equipment.</p> <p>This equipment uses high voltage that can cause electrical shock. Only qualified persons can work inside the equipment.</p>	<b>NOTICE</b>
		<p><b>Do not apply paint, anti-corrosive sealant or contact spray to plastic parts or equipment coating.</b></p> <p>Those items contain products that can damage plastic parts and equipment coating.</p>

## 3.1 Maintenance

Maintenance is important to keep the equipment in good working order. Check the items shown in the table monthly.

Item	Check point	Comments
Cabinet	Dust on the cabinets	Remove dust with a dry clean cloth. Do not use commercial cleaners to clean the equipment. Those cleaners can remove paint and markers.
LCD on Main Alarm Panel	Dust on the LCD	Wipe the LCD carefully to prevent scratching, using tissue paper and an LCD cleaner. To remove dirt or salt deposits, use the LCD cleaner, wiping slowly with tissue paper so as to dissolve the dirt or salt. Change paper frequently so the salt or dirt will not scratch the LCD. Do not use solvents such as thinner, acetone or benzene for cleaning.

## 3.2 Fuse Replacement

The fuses on the PWR Board (24P0105) inside the Processor Unit protect the system from overvoltage and overcurrent. If the power is not on, have a technician check for blown fuse(s). If a fuse(s) has blown, replace the fuse(s) with one of the same rating. If the fuse(s) blows again, contact your dealer.



Name	Type	Code No.	Qty
Fuse	FGMB-A 250V 2A PBF	000-157-497-10	2
Fuse	FGMB-A 250V 3A PBF	000-157-568-10	1

## 3.3 Troubleshooting

If the equipment appears to be abnormal, follow the procedure in the table below to try to restore normal operation. If you cannot restore normal operation, do not check inside the equipment. Get a qualified technician to check the equipment.

Problem	Remedy
The Main Alarm Panel is not powered.	<ul style="list-style-type: none"> <li>• Check if the Processor Unit is ON.</li> <li>• Check if the power cable is properly connected.</li> <li>• Check if the power cable is damaged or corroded.</li> <li>• Check the connection between the Processor Unit and the Main Alarm Panel.</li> </ul>
A key on the Main Alarm Panel is operated, but there is no response.	Reset the power with power switch on the ship's switchboard and operate the key. If the key does not respond, request service.
The results of the ROM and RAM test for the Main Alarm Panel or Processor Unit show an NG (No Good).	Reset the power with power switch on the ship's switchboard. If NG appears again, request service.
An alarm is not sent to a Cabin Panel.	Do the procedure in section 3.4 to check the connections.
The message "Failure: Communication (or Malfunction)" appears and the buzzer sounds.	The message indicates communication error between Main Alarm Panel and Processor Unit. Press any key to silence the buzzer. Reset the power with power switch on the ship's switchboard. If the problem still occurs, request service.
The message "Failure: DC" (or "Failure: AC") appears and the buzzer sounds.	The message indicates power failure of corresponding power. Press any key to silence the buzzer. Check the power supply.

### 3.4 How to Check Connection Between Processor Unit/Cabin Panel/ Timer Reset Panel

You can check the connection between the Processor Unit/Cabin Panel/Timer Reset Panel. The tested panel sends a test signal to the Processor Unit. The Processor Unit receives the test signal then commands that panel to light or flash its LEDs and sound its buzzer.

**Note:** If the Cabin Panel(s) are connected using 4-core cables (MPYC-4, or equivalent), use the **EMG** call on the Main Alarm Panel to conduct the check. The **TEST** switch on the Cabin Panel(s) is disabled when 4-core cables are used.

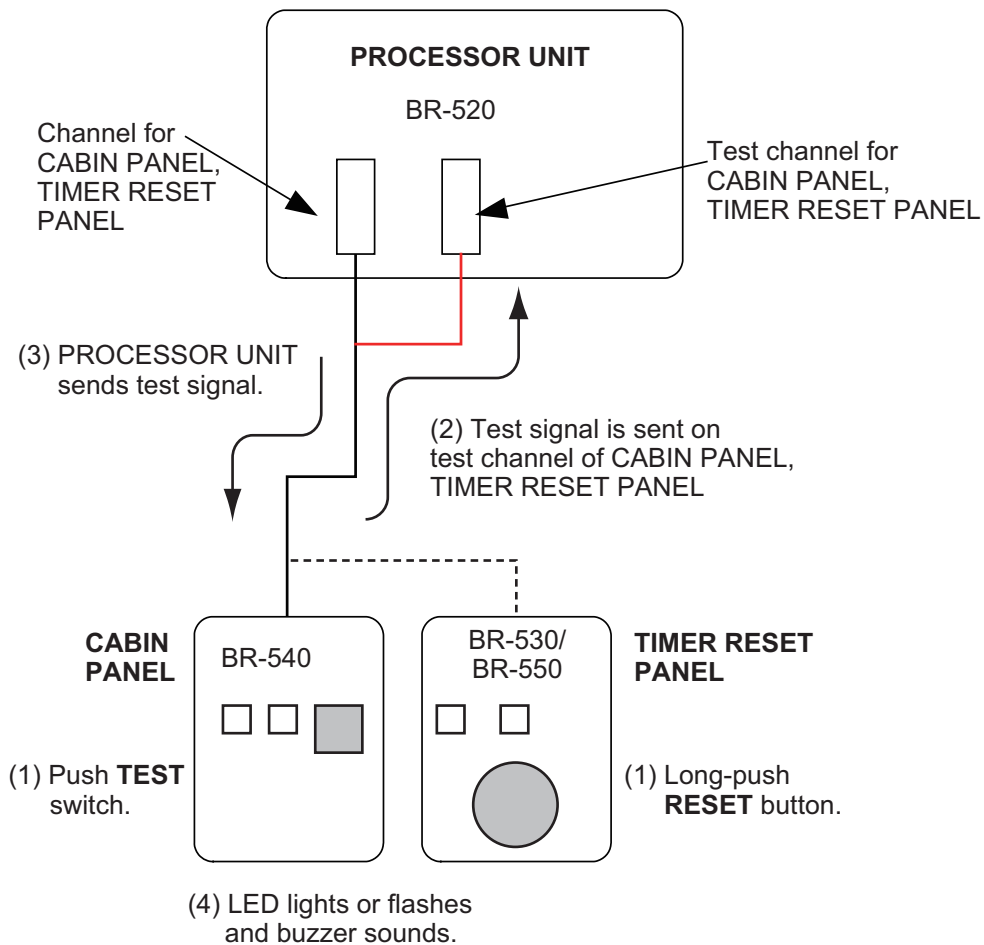

Push the **TEST** switch or **RESET** button (long-push) to start the test. The tested panel is normal if its LEDs and buzzer perform as shown in the table below.

Cabin Panel		Timer Reset Panel	
Item	Normal State	Item	Normal State
ALARM LED	Lights 5 s	ALARM LED	Flashes 5 s
DUTY LED	Lights 5 s	RESET LED	Lights
Buzzer	5 s	Buzzer	5 s

**Note 1:** The watch timer is not reset during the test.

**Note 2:** A Cabin Panel that is currently forwarding an alarm cannot be tested. However, you can test the Cabin Panels that are not forwarding an alarm. (For example, in the 2nd stage, a Cabin Panel other than the one in the back-up officer's quarters can be tested.)

### 3.5 Life Expectancy of Major Parts

The life of the fan depends on the operating environment. It is recommended to replace the fan before its expected expiration.

Unit	Part	Type	Code No.	Approx. Life
Processor Unit	Fan	MMF-06G12ES-ROD	000-174-638-10	5 years

# 4. INSTALLATION

## 4.1 Equipment Lists

### Standard supply

Name	Type	Code No.	Remarks
Main Alarm Panel	BR-510	-	
Processor Unit	BR-520	-	
Installation Materials	CP24-01701	001-117-860	For BR-510
	CP24-01800	000-018-042	For BR-520, w/10 m cable
	CP24-01801	001-117-970	For BR-520, no cable
Spare Parts	SP24-00501	001-117-990	For BR-520, for V spec.*

\* Merchant vessel

### Optional supply

Name	Type	Code No.	Remarks
Timer Reset Panel	BR-530	-	w/inst. materials CP24-01901
Cabin Panel	BR-540	-	w/inst. materials CP24-01901
Watertight Timer Reset Panel	BR-550	-	w/inst. materials CP24-02001
Motion Detector	BR-560		Max. two units, w/inst. materials CP24-01901
Flash Beacon	BR-570		Max. three units, w/inst. materials CP24-01901
Bulkhead Mount Kit	OP24-20	001-118-740	For BR-530, BR-540, BR-560, BR-570
Hanger	OP24-21	001-118-750	For BR-510, w/Inst. materials
Shield Film	OP24-22	001-118-760	For BR-510
Front Fixing Panel	OP24-34	001-195-780	For BR-530, BR-540, BR-560, BR-570
Front Fixing Panel	OP24-35	001-247-240	For BR-510
Cable Assy. (connection between BR-510 and BR-520)	FRU12-05AFFM-10M	000-175-728-10	10 m
	FRU12-05AFFM-20M	000-175-729-10	20 m
	FRU12-05AFFM-30M	000-175-730-10	30 m
	FRU12-05AFFM-40M	000-175-731-10	40 m
	FRU12-05AFFM-50M	000-175-732-10	50 m

## 4.2 Mounting Considerations

Install the units in compliance with IEC 62616 Annex A and IMO MSC.128(75).

- Locate the units away from exhaust pipes and vents.
- Make sure the location has good ventilation.
- Mount the units where shock and vibration are minimal.
- Locate the units away from the equipment that generates electromagnetic fields, such as a motor or generator.
- Allow space as indicated in the outline drawings, to facilitate maintenance and servicing.
- Follow the compass safe distances indicated on page iii to prevent interference to a magnetic compass.
- Keep the units away from direct sunlight to prevent heat that can build up inside their cabinets. The LCD of the Main Alarm Panel BR-510 can darken if put in direct sunlight.
- **For the Main Alarm Panel**, the optimal viewing distance is 0.5 m. Select a location within that distance.
- **For the Timer Reset Panel:**
  - Locate the units on the bridge where a proper lookout is available.
  - The means of activating the reset functions shall be easily accessible from the conning position, the workstation for navigating and maneuvering, and the workstation for monitoring and the bridge wings (if applicable).
  - The 1st stage audible alarm shall be audible from all operational positions on the bridge where the OOW may reasonably be expected to be stationed.
- **For the Motion Detector:**
  - The motion detector monitors movement of personnel on the bridge. The monitoring range is as shown below when the sensor is mounted on the overhead at a height of two meters. The sensor, consisting of multiple optical elements, is a passive infrared sensor that senses the movement of heat sources (personnel). The movement of a heat source is not detected when it is within the receiving beam of an optical element, and movement may not be detected in the fore-aft direction. The farther distance of the heat source from the motion detector may not be detected unless its movement is large, because the beamwidth increases with distance.

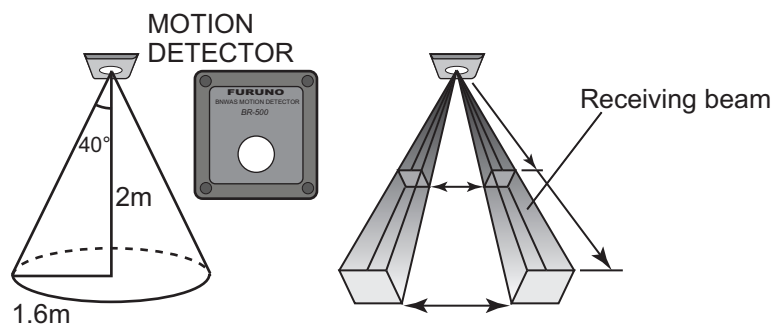

- **For the Flash Beacon**, the flashing indication shall be visible from all operational positions on the bridge where the OOW may reasonably be expected to be stationed.

## 4.3 Main Alarm Panel BR-510

The Main Alarm Panel can be mounted on a desktop or flush mounted in a console, on the bridge. Follow the mounting considerations in section 4.2 to select a location. Additionally, the unit must be located on the bridge where a proper look out is provided.

### 4.3.1 Desktop mount

This mounting method requires the optional hanger.

1. Unscrew knobs to remove the unit from the hanger.
2. Make four pilot holes (for 5×20 self-tapping screws) in the mounting location.
3. Fix the hanger to the mounting location with four self-tapping screws (5×20, supplied).
4. Attach cables to the back of the unit (see section 4.7.3).
5. Set the unit to the hanger, and fasten knobs to fix the unit.

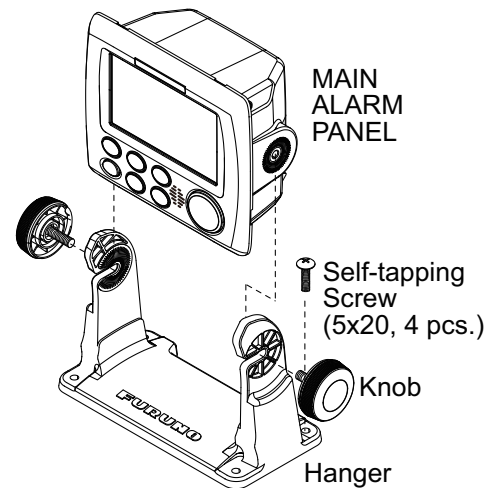

### 4.3.2 Flush mount

1. Use the template (supplied) to make a hole in the mounting location.
2. Prepare four pilot holes (for 3×20 self-tapping screws) at the mounting location.
3. Remove the front panel from the unit by unfastening the catches at the rear of the panel.
4. Set the F mount cushion (supplied) to the hole made at step 1.
5. Connect cables to the unit. (See section 4.7.3).
6. Use four self-tapping screws (3×20, supplied) to fasten the unit to the mounting location then re-attach the front panel.

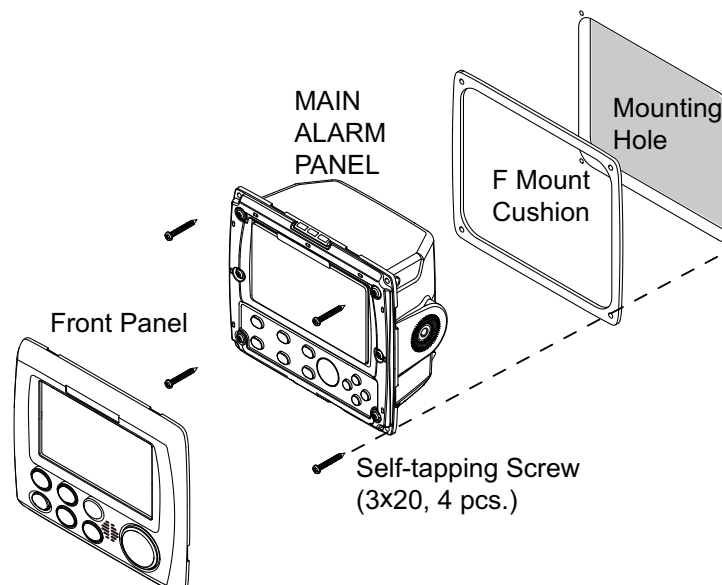

## 4. INSTALLATION

### 4.3.3 Shield film (option)

If the screen is too bright with minimum brilliance at nighttime, install the shield film to reduce the brilliance.

1. Clean the LCD with an LCD cleaning cloth.
2. Peel off the protective backing from the shield film.
3. Set the top edge of the shield film to the top edge of the panel and slowly attach the film.

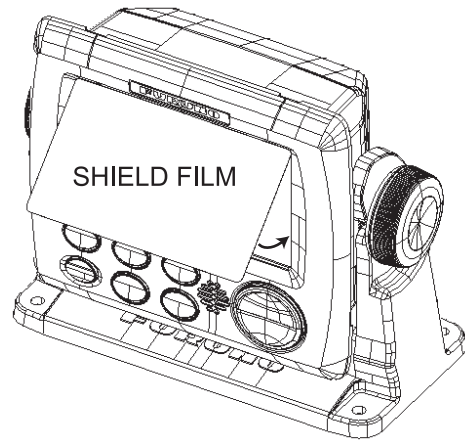

## 4.4 Processor Unit BR-520

The Processor Unit is designed to be mounted on a bulkhead or the deck. Follow the mounting considerations in section 4.2 when selecting a location.

Refer to the outline drawing at the back of this manual for dimensions. Fasten the unit with M6 bolts or 6×20 self-tapping screws. (Supply bolts locally.)

## 4.5 Timer Reset Panel BR-530, Cabin Panel BR-540, Motion Detector BR-560, Flash Beacon BR-570 (optional units)

These units can be flush mounted in a panel, or fixed to a bulkhead. Follow the mounting considerations in section 4.2 when selecting a location.

### 4.5.1 Flush mount

Prepare a cutout in the location, referring to the outline drawings. Connect the signal cable to the unit **BEFORE** you install the unit. (See section 4.7.4.) Set the unit to the cutout and fasten the unit with four 3×16 self-tapping screws (supplied).

Name	Type	Code No.	Qty	Remarks
Self-tapping Screw	3×16 SUS304	000-171-996-10	4	
Cable Tie	CV-150B	000-167-183-10	5	



### 4.5.2 Bulkhead mount (option)

This mounting method requires the optional bulkhead mount kit (Type: OP24-20, Code No. 001-118-740-00), the contents of which are shown in the table below. The cable can be led into the unit from the bottom or rear of the unit.

Name	Type	Code No.	Qty	Remarks
Mount Case	24-012-3101-0	100-362-890-10	1	
Mount Base	24-012-3102-1	100-362-901-10	1	
Clamp	24-012-3103-0	100-362-910-10	1	
Self-tapping Screw	4×20 SUS304	000-158-850-10	4	
Binding Screw	M3×8 SUS304	000-172-166-10	4	

#### Lead in the cable from the rear of the unit

1. Prepare a cutout in the mounting location, referring to the outline drawing.

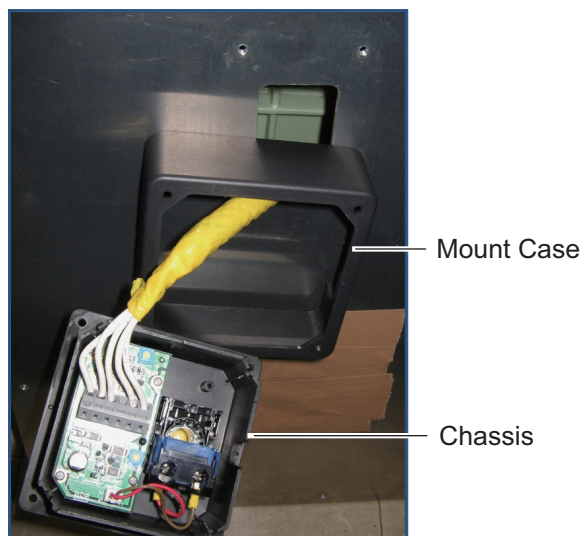

2. Pass the cable through the cutout and the Mount Case and connect it to the terminal on the Chassis.
3. Remove the Clamp from the bottom of the Mount Base. Remove the cable protector from the clamp and attach it to the supplied clamp. Attach the supplied Clamp to the rear cover with the same screws. (You may discard the clamp originally attached to the Mount Base.)

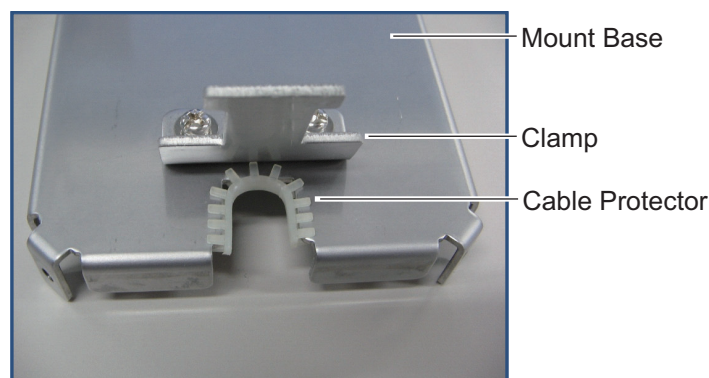

#### 4. INSTALLATION

4. Fasten the cable to the Clamp with a cable tie (local supply). As shown in the figure below, make the distance between the terminal and the cable tie 100 mm.



5. Fasten the Mount Base to the mounting location with four self-tapping screws (supplied). Fasten the Chassis to the Mount Case with four binding screws (supplied).



*Self-tapping screws*



*Binding screws*

6. Seal the bottom entry with the blind sheet supplied.

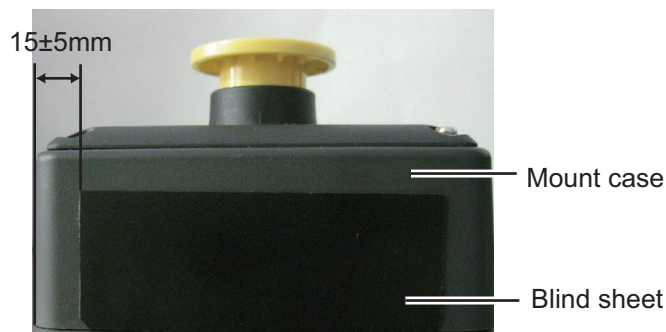

**Lead in the cable from the bottom of the unit**

1. Fasten Cable Clamp 2 to the Mount Base.

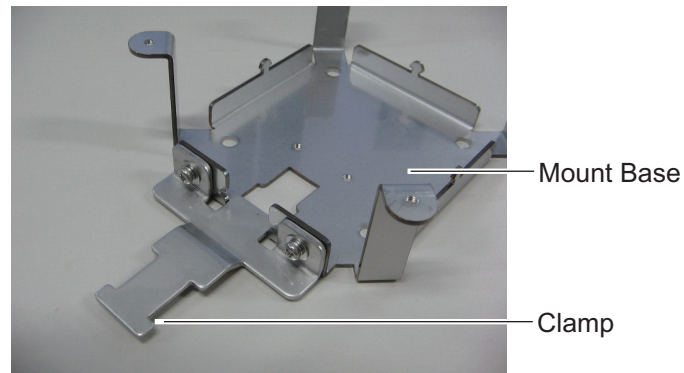

2. Fasten the Mount Base/Clamp to the mounting location with four self-tapping screws (supplied).

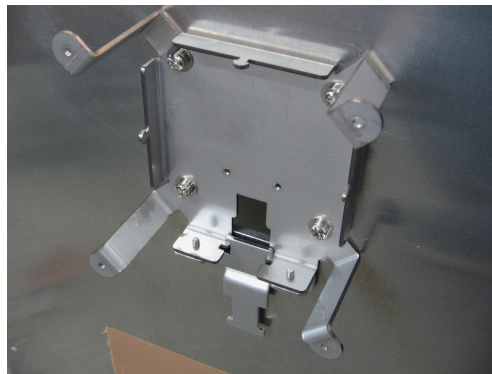

3. Pass the signal cable through the Mount Case.

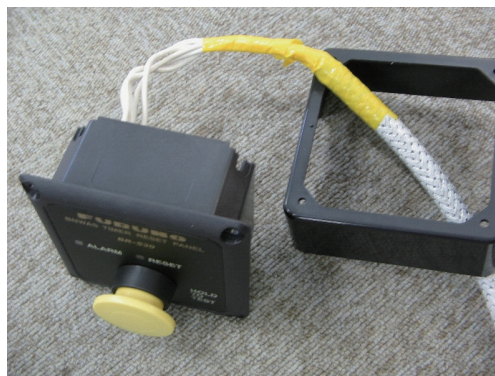

4. Connect the signal cable to the WAGO terminal block. See the interconnection diagram.

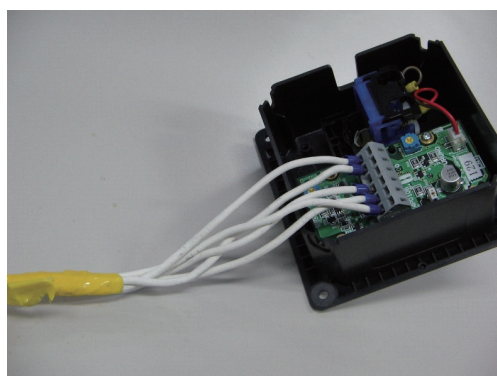

#### 4. INSTALLATION

5. Set the Chassis to the Mount Base. Set the signal cable in the notch in the Clamp.

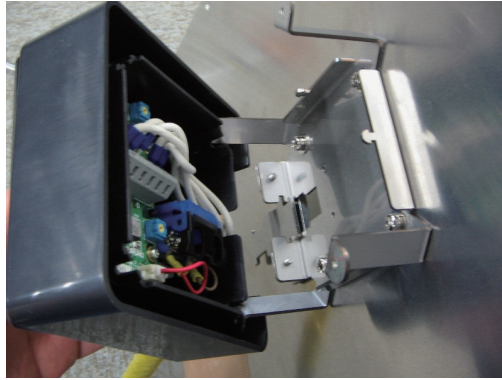

6. Fasten the Chassis to the Mount Case with binding screws (supplied)



7. Fasten the signal cable to the Clamp with a cable tie.



Cable Tie



## 4.6 Watertight Timer Reset Panel BR-550 (option)

Follow the mounting considerations in section 4.2 when selecting a location. Refer to the outline drawing at the back of this manual for dimensions.

1. Pass the signal cable through the gland and then the Nut of the Waterproof Case. Pass the cable into the unit. Process the cable as shown on page 4-13.

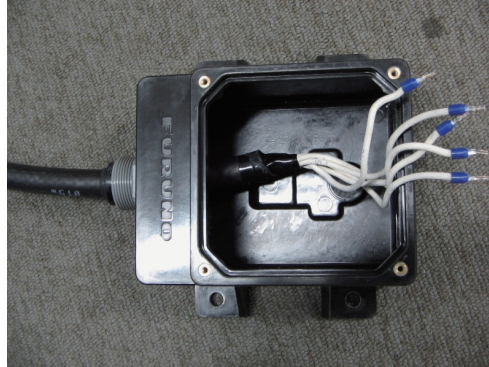

2. Connect the signal cable to the WAGO terminal block on the Chassis. See the interconnection diagram.

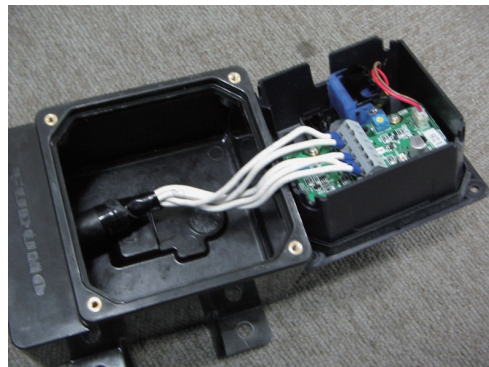

3. A gasket is fitted on the Chassis. Confirm that the gasket is correctly seated. If not correctly seated, re-seat the gasket, referring to the illustration below for the inserting direction.

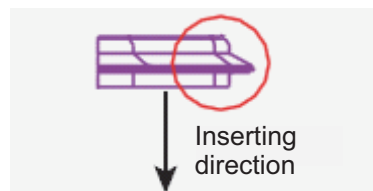
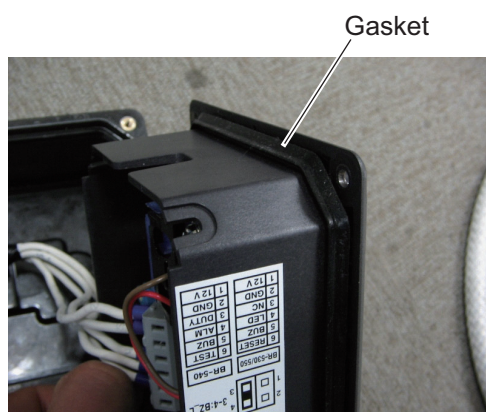

4. Fasten the Chassis to the Waterproof Case with the screws supplied. Do not use other types of screws; watertight integrity cannot be guaranteed.

#### 4. INSTALLATION

5. Tighten the nut.



6. Fasten the unit to the mounting location with the supplied self-tapping screws (6×30, Code No. 000-162-614-10).



## 4.7 Wiring

### 4.7.1 Processor Unit

There are two power terminals: AC and DC. Connect each power cable to its power terminal. Connect the signal cables to their appropriate WAGO terminal blocks on the MAIN Board. Use the terminal opener (attached inside the Processor Unit) to open the WAGO terminal blocks.

Use the cable ties (supplied) to bind the cables to the cable posts on the Processor Unit. Close the shield cover. Run a ground wire (IV-2sq) between one of the two earth terminals on the unit and the ship's ground.

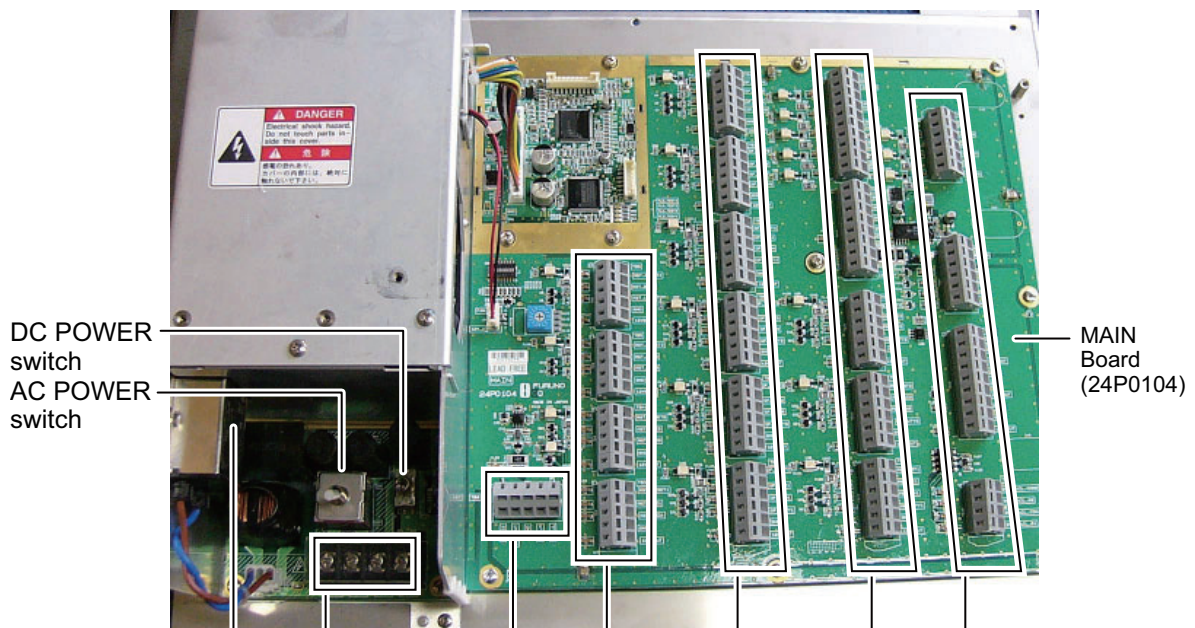

DC POWER switch  
AC POWER switch

PWR Board  
(24P0105)

TB1: Power cables  
From Left:  
#1, #2: AC  
#3: 24 VDC (+)  
#4: 24 VDC (-)

TB2: Main Alarm Panel BR-510

From Top:  
TB12, TB11,  
TB10, TB9,  
TB8, TB7:  
Cabin Panel BR-540 (Backup Officer)

From Top:  
TB21: Operator Fitness,  
TB20: VDR, Other  
TB19: Flash Beacon BR-570  
TB18: Alarm System, VDR

**Cables to use \*1**

- TB1: DPYC-1.5 (AC), DPYC-2.5 (DC)
- TB2: FRU12-05AFFM
- TB3 - TB6: MPYC-7 (or MPYCY-7)
- TB7 - TB15: MPYC-7 (or MPYC-4\*2)
- TB16, TB17: MPYC-4
- TB18: MPYC-2
- TB19: MPYC-4
- TB20: TTYCS-1
- TB21: MPYC-2

\*1 Cables shown are JIS (Japan Industrial Standard) cables. Use equivalent if not available locally. See "JIS Cable Guide" in the Appendix for how to find equivalent cable.

\*2 The TEST function and DUTY LED are disabled when this cable is used.

From Top:  
TB6, TB5  
TB4, TB3:  
Timer Reset Panel BR-530, Watertight  
Timer Reset Panel BR-550

From Top:  
TB17: Motion Detector BR-560 signal in, Backup Navigator  
TB16: Autopilot, Motion Detector BR-560 power  
TB15, TB14,  
TB13: Cabin Panel BR-540 (Public)

**To connect BR-560**, connect it to TB 16 and TB17(or TB21) with cable MPYC-4.

**To connect Back-up Navigator, Operator fitness**, connect to TB17 or TB21 with cable MPYC-2.

**How to fabricate and fix cables to the Processor Unit**

**Power cables for Processor Unit (DPYC-1.5 (AC power), DPYC-2.5 (DC power))**

L=Distance from cable clamp to terminal connection

Sheath  
Armor

Cut the sheath.

6

Vinyl tape

Crimp-on lug  
Inner diameter ø4  
Outer diameter ø7

Set this part in cable clamp.

DPYC-1.5:  $\phi = 11.7$  mm  
DPYC-2.5:  $\phi = 12.8$  mm

Armor  
Sheath

Conductor  
DPYC-1.5:  
S = 1.5 mm<sup>2</sup>  
 $\phi = 1.56$  mm  
DPYC-2.5:  
S = 2.5 mm<sup>2</sup>  
 $\phi = 2.01$  mm

---

**MPYC-2 (Operator Fitness), MPYC-4<sup>\*1</sup> (Motion Detector, Flash Beacon)  
MPYC-7<sup>\*2</sup> (Cabin Panel, Timer Reset Panel)**

<sup>\*1</sup> Also available for Cabin Panel connection.

L=Distance from cable clamp to terminal connection

Sheath  
Armor

Cut sheath.

3

6

Connect cores to WAGO terminal block.

Vinyl tape

Set this part in cable clamp.

MPYC-2  
 $\phi = 10.0$  mm

Armor  
Insulator  
Sheath  
Conductor  
S = 1 mm<sup>2</sup>  
 $\phi = 1.29$  mm

MPYC-4  
 $\phi = 11.2$  mm

MPYC-7  
 $\phi = 13.2$  mm

<sup>\*2</sup> Use MPYCY-7 for Watertight Cabin Panel.

---

**TTYCS-1 (VDR)**

L=Distance from cable clamp to terminal connection

Shield

Remove paint.

50

Cut vinyl sheath.

Pull out cables from shield;  
solder vinyl wire to shield.

6

Connect cores to WAGO terminal block.

Vinyl tape

Set this part in cable clamp.

TTYCS-1  
 $\phi = 10.1$  mm

Armor  
Sheath  
Shield

Conductor  
S = 0.75 mm<sup>2</sup>  
 $\phi = 1.11$  mm



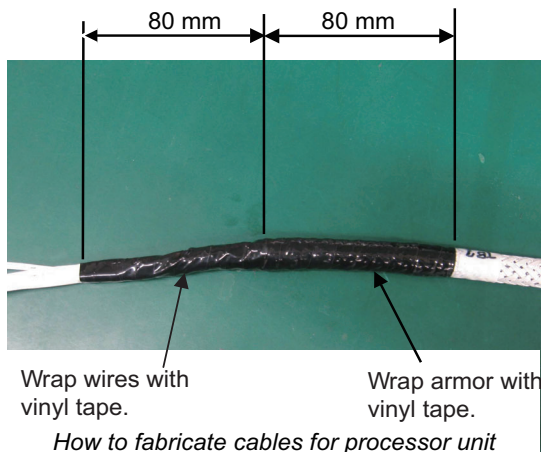
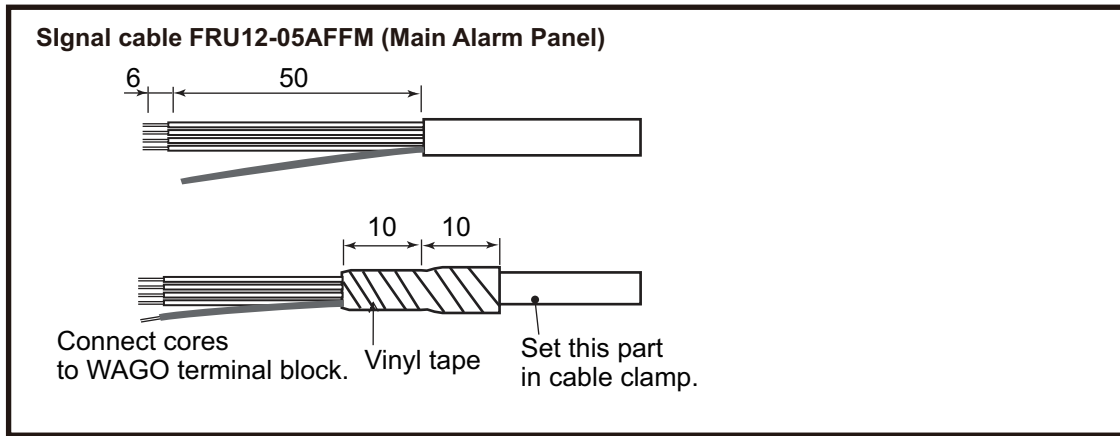

*Fix cables to post with cable tie*

### 4.7.2 Wiring information

Item	Description
Operator fitness	<ul style="list-style-type: none"> <li>• <b>FAR-2105:</b> It is not possible to create a connection for operator fitness between FAR-2105 and the Processor Unit, because the FAR-2105 does not have operator fitness output.</li> <li>• <b>FAR-2107:</b> Use port J612 (#7/8 for operator fitness), where a contact signal is available.</li> <li>• <b>Other makes of radars:</b> Check for availability of contact signal.</li> </ul>
FRU12-05AFFM (between BR-510 and BR-520)	This cable is fit with a Micro-C connector (male) on one end and a stripped end for connection to the BR-520. The standard length is 6 m. 10 m, 20 m, 30 m, 40 m, and 50 m cables are optionally available.
Cable MPYC-7 (between BR-530/550 and BR-520)	40 m and the total length for all units is max. 150 m. For example, when four BR-530 are installed: No.1 BR-530: 40 m No. 2 BR-530: 40 m No. 3 BR-530: 40 m No. 4 BR-530: 30 m Total length: 150 m
Motion Detector BR-560	<ul style="list-style-type: none"> <li>• Pyroelectric detection</li> <li>• Detection range: Up to 5m, 80°×80°</li> <li>• Detection rate: 0.8 thru 1.2 m/s</li> <li>• Detection sensitivity: 4°C (difference from surround in temperature)</li> </ul> <p>Generally, up to two Motion Detectors can be installed, at INPUT3/4 and INPUT5-8. Also, INPUT port 2 can be used by setting [INPUT2] on the Service menu to [Timer Reset].</p>
INPUT2 (TB17)	Backup Navigator signal or Timer Reset signal (operator fitness, motion detector) can be connected to the INPUT Port 2. Select the signal from the Service menu. When the Backup navigator mode is used, set the external equipment's output signals as follows: Power off: CLOSE, Normal working: CLOSE, Alarm generated: OPEN

#### 4. INSTALLATION

Item	Description																				
System failure (TB18)	<p>The behavior changes according to the alarm mode.</p> <table border="1" data-bbox="652 253 1230 584"> <thead> <tr> <th data-bbox="655 253 951 360" rowspan="2"><u>Status</u></th> <th colspan="2" data-bbox="951 253 1227 293"><u>Mode</u></th> </tr> <tr> <th data-bbox="951 293 1102 360">Alert I/F1 Alert I/F2</th> <th data-bbox="1102 293 1227 360">Legacy</th> </tr> </thead> <tbody> <tr> <td data-bbox="655 360 951 405">Normal</td> <td data-bbox="951 360 1102 405">OPEN</td> <td data-bbox="1102 360 1227 405">CLOSE</td> </tr> <tr> <td data-bbox="655 405 951 450">Communication failure</td> <td data-bbox="951 405 1102 450">OPEN</td> <td data-bbox="1102 405 1227 450">OPEN</td> </tr> <tr> <td data-bbox="655 450 951 495">AC failure</td> <td data-bbox="951 450 1102 495">OPEN</td> <td data-bbox="1102 450 1227 495">OPEN</td> </tr> <tr> <td data-bbox="655 495 951 539">DC failure</td> <td data-bbox="951 495 1102 539">OPEN</td> <td data-bbox="1102 495 1227 539">OPEN</td> </tr> <tr> <td data-bbox="655 539 951 584">POWER failure</td> <td data-bbox="951 539 1102 584">CLOSE</td> <td data-bbox="1102 539 1227 584">CLOSE</td> </tr> </tbody> </table>	<u>Status</u>	<u>Mode</u>		Alert I/F1 Alert I/F2	Legacy	Normal	OPEN	CLOSE	Communication failure	OPEN	OPEN	AC failure	OPEN	OPEN	DC failure	OPEN	OPEN	POWER failure	CLOSE	CLOSE
<u>Status</u>	<u>Mode</u>																				
	Alert I/F1 Alert I/F2	Legacy																			
Normal	OPEN	CLOSE																			
Communication failure	OPEN	OPEN																			
AC failure	OPEN	OPEN																			
DC failure	OPEN	OPEN																			
POWER failure	CLOSE	CLOSE																			

#### 4.7.3 Main Alarm Panel

Connect the Processor Unit to the CAN bus connector with the cable FRU12-05AFFM (supplied). Run a ground wire (IV-2sq) between the ground terminal and ship's ground.

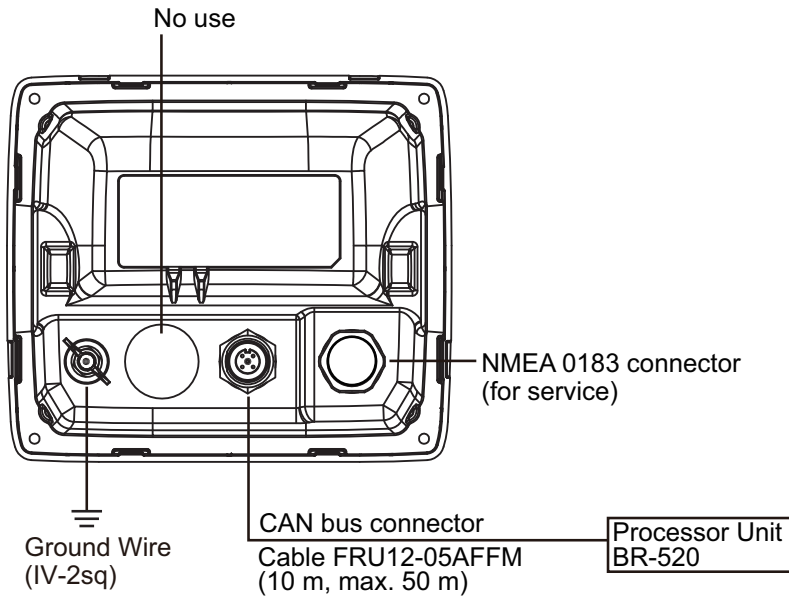

### 4.7.4 Timer Reset Panel, Cabin Panel, Motion Detector, Flash Beacon

The wiring procedure is common to all the above-mentioned units.

Cable to use	Description
Cable MPYC-7 (between respective unit and BR-520)	Timer Reset Panel Max. length of single cable: 40 m Max. length: of all cables: 150 m Cabin Panel Max. length of single cable: 80 m Max. length of all cables: 300 m Cable total length Cabin Panel: max. 300 m Timer Reset Panel: max. 150 m

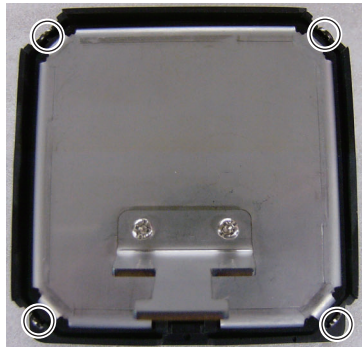

1) Loosen four screws to remove rear cover.



2) Process cable and connect cable to WAGO terminal block. Use terminal opener (inside Processor Unit) to open terminals. (Shown: Timer Reset Panel)



3) Close rear cover. Fasten cable to clamp with cable tie (supplied).

### 4.7.5 Flash Beacon

The LED of the Flash Beacon can be adjusted externally. Connect a junction box (local supply) and external dimmer (3 kΩ, local supply) as shown below to enable the adjustment.

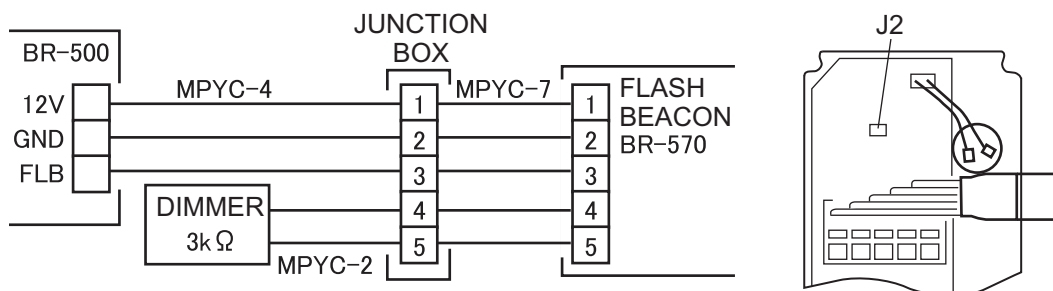

To use an external dimmer, set the jumper block J2 to the 1-2 position.

## 4. INSTALLATION

### 4.7.6 How to fabricate cables for the Cabin Panel, Timer Reset Panel, Flash Beacon and Motion Detector

Fabricate the above-mentioned cables as shown below.

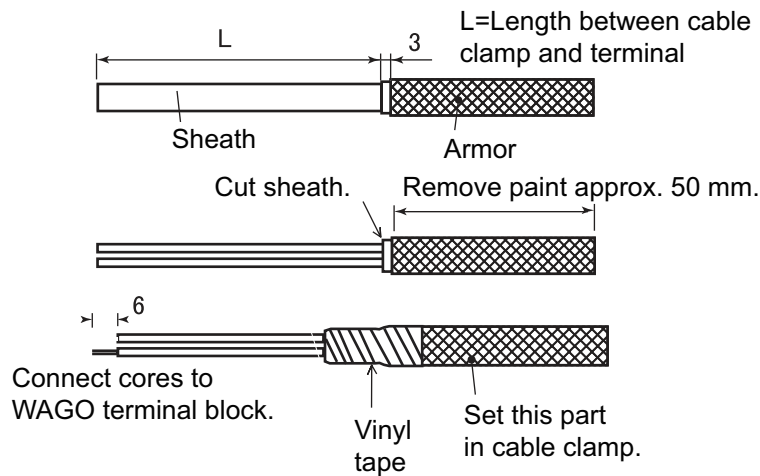

## 4.8 DIP Switch, Rotary Switch Settings

A DIP switch and a Rotary switch are provided in the Processor Unit to adjust the equipment according to applicable regulations and ship's requirements.

### Location of switches in the Processor Unit

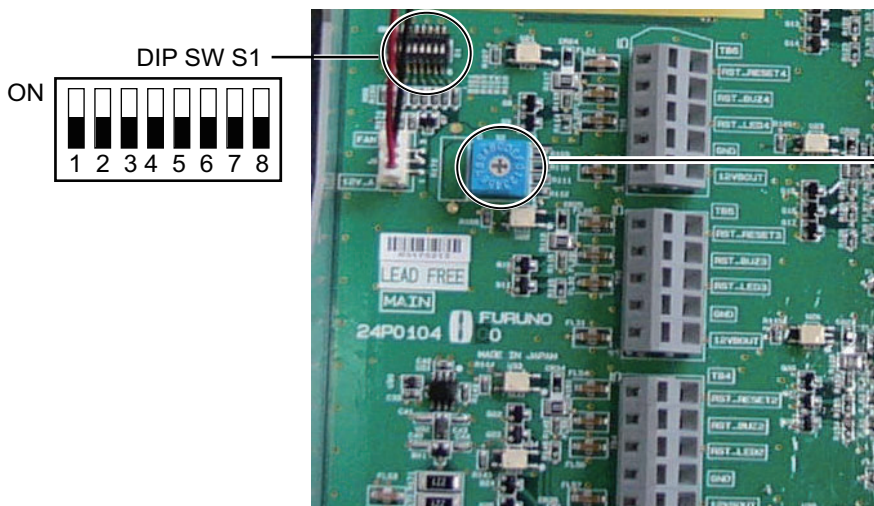

### Rotary SW S2

SW position	Frequency
<b>0</b>	<b>4.2 kHz</b>
1	4.15 kHz
2	4.25 kHz
3	4.2 kHz
4	4.2 kHz
5	4.2 kHz
6	4.2 kHz
7	4.2 kHz
8	4.2 kHz
9	4.2 kHz
0	4.2 kHz
A	4.2 kHz
B	4.2 kHz
C	4.2 kHz
D	4.2 kHz
E	4.2 kHz
F	4.2 kHz

Default setting in bold italic

**DIP SW S1**

The DIP SW S1 allows adjustment of the items listed in the table below. The items in bold are the default settings.

SW No.	Function	DIP SW Setting	
		OFF	ON
1	Boot program overwrite	<b>Enabled</b>	Disabled
2	I/O test	<b>Disabled</b>	All LEDs, System Fail and Flash Beacon go ON.
3	ALR output (fixed interval output)	<b>30s</b>	60s
4	Flash Beacon function (2nd and 3rd stages)	<b>Flashing</b>	OFF
5	Processor Unit startup	<b>Normal startup</b>	Startup disabled. (For updating the program of the MAIN ALARM PANEL.)
6	IEC 61162 Baud rate	<b>4800 (bps)</b>	38400 (bps)
7	Sending Alarm at 2nd stage	<b>None</b>	Yes
8	No use		

**Rotary SW S2**

The Rotary SW S2 changes the frequency of the buzzer. Use a plastic screwdriver to turn the switch to the appropriate position. See the illustration above for switch position and frequency.

**4.9 How to Adjust LED Brilliance**

The brilliance of the LEDs on the BR-530, BR-540, BR-550 and BR-570 can be adjusted. If the brilliance is too low or too high, adjust the corresponding potentiometer. Turn the potentiometer clockwise to raise brilliance, counterclockwise to lower it.

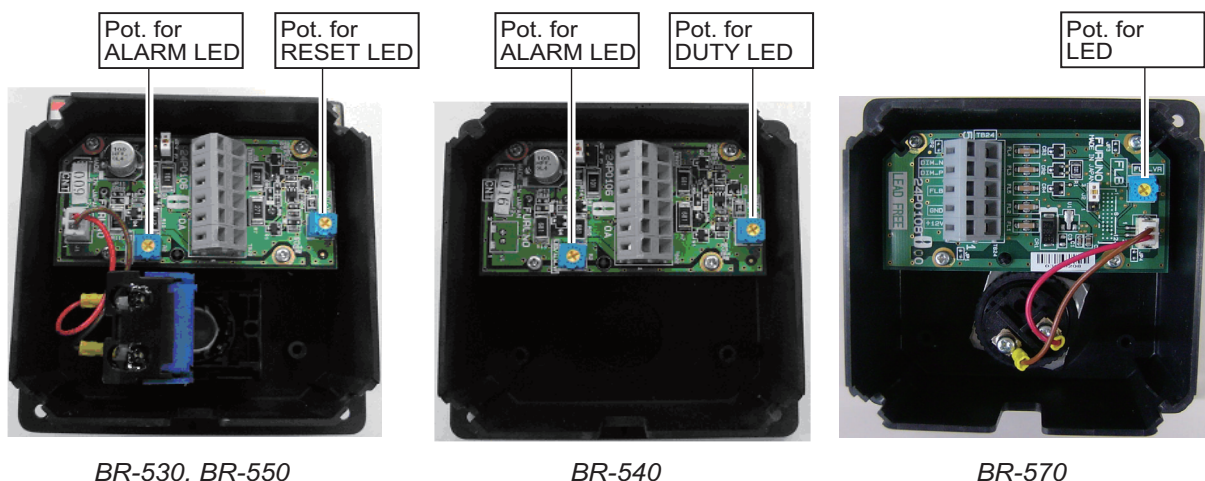

## 4.10 Menu Settings

### 4.10.1 Administrator Menu

The Administrator Menu has initial settings that set the system according to the requirements of your vessel. Only the Administrator of the system can enter the initial settings.

1. Press the **MENU/ESC** key.
2. You are asked to enter the password. If the password is correct, the [Administrator Menu] is displayed.

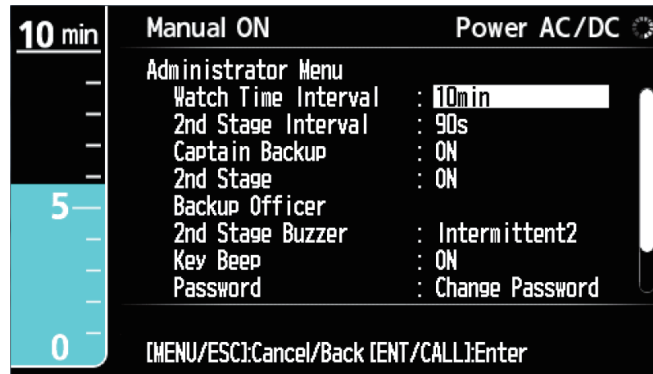

3. Use the up or down arrow on the CursorPad to select a menu item then press the **ENT/CALL** key. An options window or spinner box appears depending on your selection.



Options window  
(Buzzer Type)

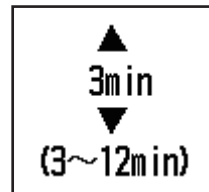







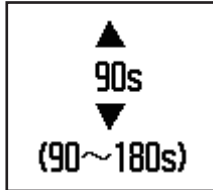

Spinner box  
(Watch Time Interval)

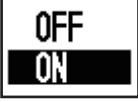
4. Use the up or down arrow on the CursorPad to select an option or set a value then press the **ENT/CALL** key.

#### Description of Administrator menu

Menu Item	Description	Options
Watch Time Interval	Set the watch time interval.	
2nd Stage Interval	Set the time interval for the 2nd stage.	



Menu Item	Description	Options
Captain Backup	<p>Select whether to include the Captain as a back-up navigation officer. That is, select whether to forward the alarm to the Cabin Panel in the Captain's quarters in the 2nd stage or the 3rd stage. <b>OFF</b>: Forward in 3rd stage. <b>ON</b>: Forward in 2nd stage.</p> <p>When [Captain Backup] is set to [ON], the captain icon is underlined.</p>	
2nd Stage	<p>Select whether to omit 2nd stage alarm or not. <b>OFF</b>: Omit alarm. <b>ON</b>: Don't omit alarm.</p>	
Backup Officer	<p>Change the name of navigation officers; add navigation officers; set the function of the Cabin Panel in the quarters of the Captain.</p> <p><b>How to select the function of the Cabin Panel in the quarters of the Captain:</b></p> <ol style="list-style-type: none"> <li>1) Select [1 CAPTAIN].</li> <li>2) Press the <b>ENT/CALL</b> key.</li> <li>3) Select [Backup] or [Captain]. If [Captain] is selected, a small "C" appears before the first backup officer's name in the backup officer list on the BNWAS display.</li> </ol>  <p><b>Names of Navigation Officers (default)</b></p>  <p><b>Function of Cabin Panel in quarters of Captain</b></p> <p><b>How to change the name of navigation officers, add navigation officers:</b></p> <ol style="list-style-type: none"> <li>1) Select a name. (To add an officer, select a blank line.)</li> <li>2) Press the <b>ENT/CALL</b> key to show the spinner box for setting name.</li> </ol>  <ol style="list-style-type: none"> <li>3) Use the right or left arrow on the CursorPad to set the cursor on a character.</li> <li>4) Use the up or down arrow on the CursorPad to select a character.</li> </ol> <p><b>Note:</b> You can clear the entire line by long-pushing the <b>ENT/CALL</b> key.</p> <ol style="list-style-type: none"> <li>5) Repeat steps 3 and 4 to change other characters.</li> <li>6) Finally, press the <b>ENT/CALL</b> key to finish.</li> </ol>	<p><b>Names of Navigation Officers (default)</b></p>  <p><b>Function of Cabin Panel in quarters of Captain</b></p> 
2nd Stage Buzzer	<p>Select the 2nd stage buzzer type. Intermittent1: ON: 200 ms, OFF: 250 ms Intermittent2: ON: 200 ms, OFF: 400 ms</p>	
Key Beep	<p>Turn the key beep on or off.</p>	

#### 4. INSTALLATION

Menu Item	Description	Options
Password	Change the administration password; reset the password to factory default. See the procedure on the next page.	<div style="border: 1px solid black; padding: 5px;"> <p><b>Change Password</b></p> <p>Reset Password</p> </div>
Self TEST	Check the equipment for proper operation. See the below.	
Language	Choose the language: English, Japanese, Chinese, Korean, or Russian.	<div style="border: 1px solid black; padding: 5px;"> <p><b>English</b></p> <p>日本語</p> <p>中文</p> <p>한국어</p> <p>Русский й</p> </div>

#### Self TEST

The self test checks the equipment for proper operation.

1. Use the CursorPad to select [Self TEST] from the Administrator menu then press the **ENT/CALL** key.

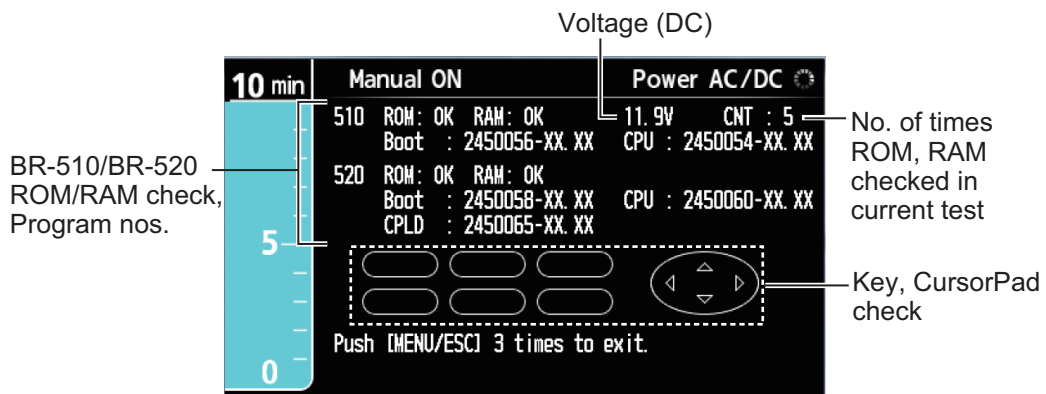

#### **Self test description**

- The ROM and RAM of the Main Alarm Panel and Processor Unit are checked. The results are shown as "OK "or "NG" (No Good). If an "NG" appears, try the test again. If "NG" still appears, have a technician check the set.
  - The Boot and CPU program numbers of the Main Alarm Panel and the Processor Unit are shown.
  - The program no. of the CPLD (Complex Programmable Logic Device) in the Processor Unit is shown.
  - The rectangles and oval below the program numbers are for checking the keys and CursorPad. Press a key or an arrow on the CursorPad. The key's/arrow's on-screen location "lights" in red if the key/arrow is normal. Press the key/arrow again to remove the red.
2. To quit the Self TEST, press the **MENU/ESC** key three times.



**How to change the password**

1. Use the CursorPad to select [Password] from the Administrator menu then press the **ENT/CALL** key.
2. Select [Change Password], then press the **ENT/CALL** key. The Input new password box is highlighted in yellow.

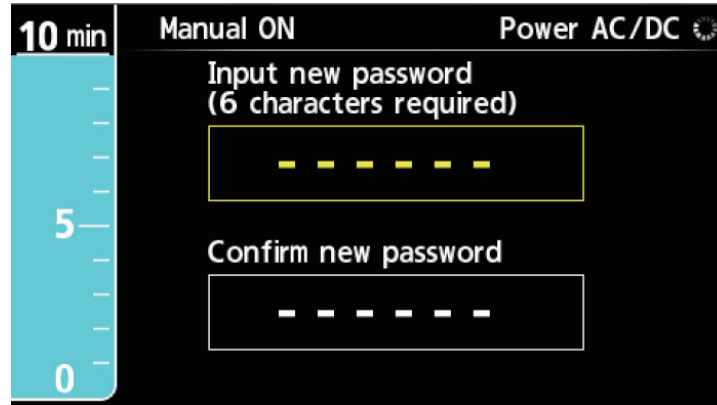

3. Set the password using a combination of the following keys; **MENU/ESC**, **ENT/CALL**, up arrow, down arrow, left arrow, right arrow. Each key press changes the displayed characters to asterisks "\*". A total of six character must be input for the new password.
4. After the sixth character is input, the cursor moves to the Confirm Password box and the box is highlighted in yellow. Input the password set at step 2.
5. If the passwords input at step 2 and step 3 match, a pop up message confirming the change is displayed.

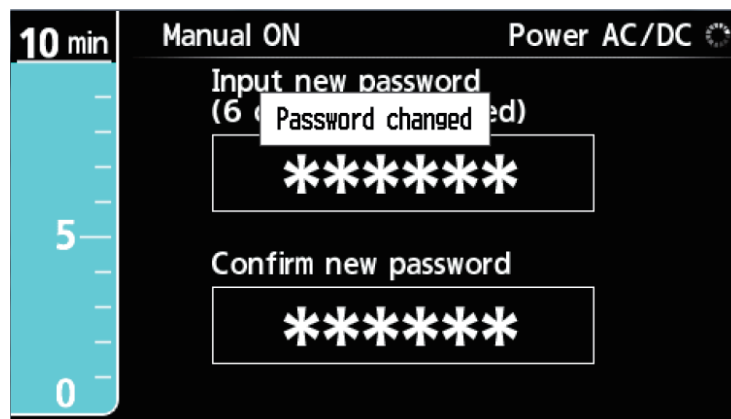
**Possible error messages and their meaning:**

1. "Password invalid Use a different password" - The characters used for the password are invalid, repeat the process from step 1.
2. "Passwords do not match Failed to change password" - The passwords set at step 2 and step 3 are not the same. Repeat the process using the same password for step 2 and step 3.

**How to reset the password to factory default:**

1. Select [Reset Password], then press the **ENT/CALL** key. A confirmation pop up is displayed.
2. Select [Yes] to reset the password, [No] to cancel, then press the **ENT/CALL** key.

### 4.10.2 Service Menu

The Service Menu contains items for the installer and the service technician. Contact a sales representative or service technician for the password.

1. Press the **MENU/ESC** key.
2. You are asked to enter the password.

**Note:** If the BNWAS is active, the message shown right appears. The cursor is selecting "Yes"; press the **ENT/CALL** key to show the Service Menu.

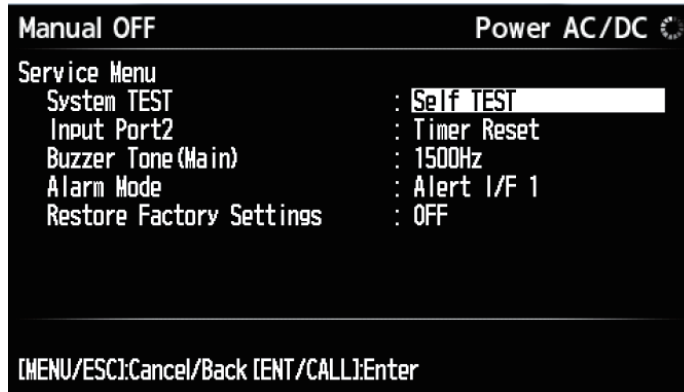
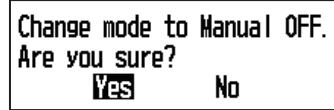

Menu Item	Description	Options
<b>System TEST</b>	Self TEST and LCD TEST. The Self TEST checks the system for proper operation. The LCD TEST checks the LCD on the Main Alarm Panel for proper display of colors.	
<b>Input Port2</b>	Select the function for input port 2, Backup Navigator or Timer Reset. If Backup Navigator is set without connection to external equipment, the emergency calling is activated. When the emergency calling occurs, Set the menu to "Timer Reset" after the input port 2 is closed (shorten).	
<b>Buzzer Tone (Main)</b>	Set the frequency for the buzzer of the Main Alarm Panel, 1300-1699 (Hz).	
<b>Alarm Mode</b>	Set the Alarm Mode according to the ship's class. Select [AlertI/F1] or [AlertI/F2] for alarm control with AMS.	[Legacy] [AlertI/F1] [AlertI/F2]
<b>Restore Factory Settings</b>	Restore all default settings. See the next page for the procedure.	

### Alarm Mode

The following functions are different from Alarm Mode setting;

<b>Alarm Mode</b>	<b>Alert I/F1</b>	<b>Alert I/F2</b>	<b>Legacy</b>
BR-510 Alarm indication ceasing	The cause of malfunction is resolved and an Acknowledge is received	The cause of malfunction is resolved and an Acknowledge is received	The cause of malfunction is resolved
TB18	Power fail: Close at loss of the power source.	Power fail: Close at loss of the power source.	System fail: Open at malfunction of source or system.
ALR sentence	Output the sentences for AMS and BNWAS.	Output the sentences for BNWAS only.	Output the sentences for BNWAS only.

When a malfunction is detected at start up, BR-520 goes into the Legacy mode. After the cause of malfunction is canceled, BR-520 goes back to the setting mode automatically.

### How to restore factory settings

1. Open the Service menu.
2. Use the CursorPad to select [Restore Factory Settings] then press the **ENT/CALL** key.
3. Use the CursorPad to select [ON] then press the **ENT/CALL** key.

<p><b>Restore Factory Settings</b>  <b>Are you sure ?</b>  <b>Yes</b>      <b>No</b></p>
--

4. Use the CursorPad to select "Yes" then press the **ENT/CALL** key.
5. The equipment restarts, the default settings are restored then the BNWAS display re-appears.

After the unit is restarted, the audible alarm may sound. Press any key to silence it. Normal operation is restored automatically with no interruption to communication.

## 4.11 I/O Sentence Information

Communication specification:

Baud rate: 4800/38400 bps (DIP SW S1 No.6)

Data bits: 8, Stop bits: 1, Parity: None, Characters: ASCII

**Note 1:** The ACK sentence is only input or output under LEGACY or Alert I/F1 alarm modes.

**Note 2:** ACN, ALC, ALF and ARC sentences are only input or output under Alert I/F2 alarm mode. The input sentence ACN is effective from talkers CA/II/IN.

[Input Sentences]

### **EVE**

Reception of EVE sentence

↓

When in Dormant Period, Prewarning or 1st Stage, Timer will be reset

### **ACN**

Reception of ACN sentence

↓

Execute according to "Alert command" within ACN sentence

[Output Sentences]

### **ALC**

Regularly transmitted every 30 seconds

### **ALF**

ALF sentence will be transmitted in the following conditions:

- Alert status is altered;
- Alert command by ACN is received; or
- Escalation Counter is incremented.

### **ARC**

Transmitted when rejecting ACN sentence

Serial Interface

Input port (RD-A, RD-B)

Input Impedance: 110 ohms

Threshold:  $\pm 0.2$  V (A-B)

Isolation Voltage: 2500 Vrms

Output port (TD-A, TD-B)

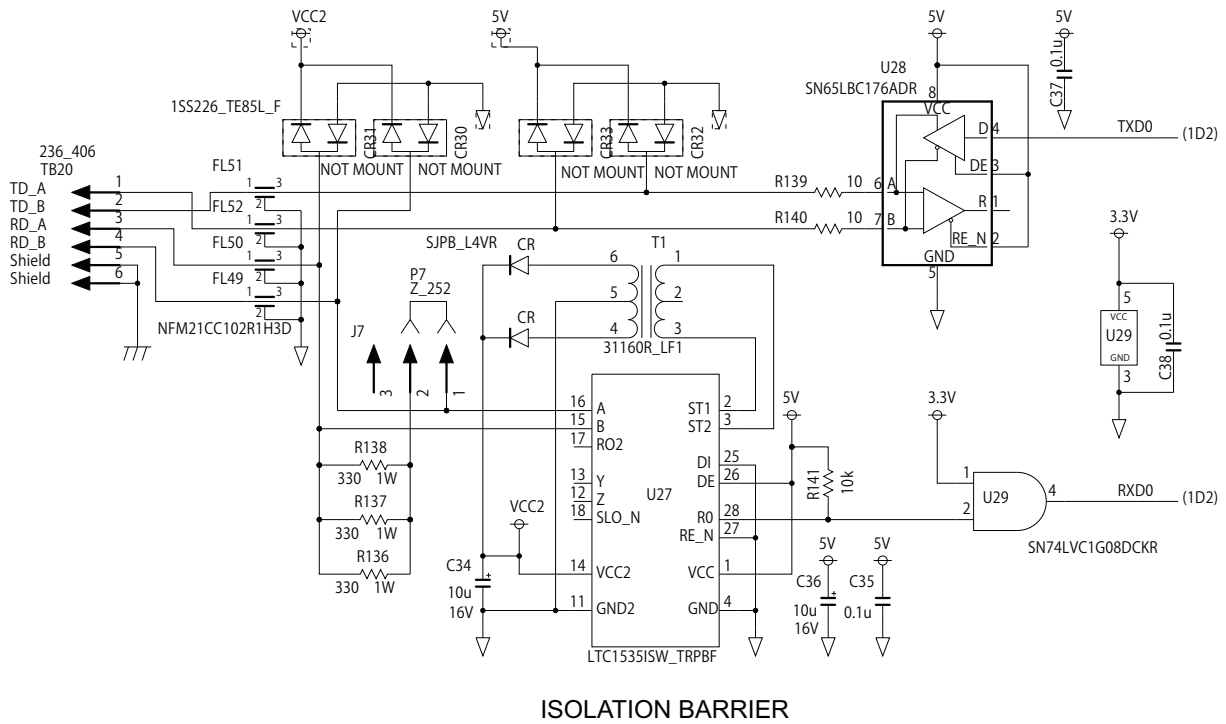

### 4.11.1 Input sentences

#### **ACK - Acknowledge alarm**

\$\*\*ACK,xxx\*hh<CR><LF>  
1

1. -xxx: Unique alarm number (identifier) at alarm source

#### **Alarm mode: [Legacy]**

- 010: Communication failure
- 011: Power failure AC
- 012: Power failure DC

#### **Alarm mode: [Alert I/F1]**

- Null: routine transmission from AMS
- 250: Malfunction

#### **ACN - Alert Command**

\$\*\*ACN,hhmmss.ss,aaa,x.x,x.x,c,a\*hh<CR><LF>  
1 2 3 4 5 6

1. No use
2. Manufacturer mnemonic code (3 digit alphanumeric code), null
3. Alert identifier (0 to 9999999)
4. Alert instance (1 to 999999, null)
5. Alert command (A=ACK from ext. equipment, Q=Request from ext. equipment, O=Responsibility transfer, S=Silence from ext. equipment)
6. Sentence status flag (C should not be null field. Sentence without C is not a command.)

## 4. INSTALLATION

### **EVE - General event message**

\$\*\*EVE,hhmmss.ss,c--c,c-c\*hh<CR><LF>  
          1          2  3

1. --hhmmss: Event time (for future use)
2. -c--c: Tag code used for identification of source of event (for future use)
3. -c--c: Event description (for future use)

### **4.11.2 Output sentences**

Talker:BN

#### **ALC - Cyclic alert list**

\$BNALC,xx,xx,xx,x.x,aaa,x.x,x.x,x.x,"""\*hh<CR><LF>  
          1  2  3  4  5  6  7  8  9

1. Total number of sentences this message (01 to 99)
2. Sentence number (01 to 99)
3. Sequential message identifier (00 to 99)
4. Number of alert entries (0 to n)
5. Manufacturer mnemonic code (null)
6. Alert identifier (0 to 9999999)
7. Alert instance (1 to 999999, null)
8. Revision counter (1 to 99)
9. Additional alert entries (same as 5 and 8. When #4=0, #5 to #9 are deleted.)

#### **ALF - Alert sentence**

\$BNALF,x,x,x,hhmmss.ss,a,a,a,aaa,x.x,x.x,x.x,x,c--c\*hh<CR><LF>  
          1  2  3      4      5  6  7  8  9  10  11  12  13

1. Total number of ALF sentences this message (1, 2)
2. Sentence number (1, 2)
3. Sequential message identifier (0 to 9)
4. Time of last change (null)
5. Alert category (A=Alert category A, B=Alert category B), null
6. Alert priority (A=Alarm, W=Warning, C=Caution), null when #2 is 2.
7. Alert state (V=Not ACKed, S=Silence, A=ACKed, O/U=Resolved, Not ACKed, N=Normal state), null when #2 is 2.
8. Manufacturer mnemonic code (null)
9. Alert identifier (0 to 9999999)
10. Alert instance (1 to 999999, null)
11. Revision counter (1 to 99)
12. Escalation counter (0 to 9)
13. Alert text (max. 16 characters for the 1st sentence, maximum length of the field for the 2nd sentence later)

#### **ARC - Alert command refused**

\$BNARC,hhmmss.ss,aaa,x.x,x.x,c\*hh<CR><LF>  
          1  2  3  4  5

1. (null)
2. Used for proprietary alerts, defined by the manufacturer (null)
3. Alert identifier (0 to 9999999)
4. Alert instance (1 to 999999, null)
5. Refused Alert Command(A, Q, O, S)  
    A=acknowledge  
    Q=request/repeat information  
    O=responsibility transfer  
    S=silence

**ALR - Alarm sentence**

\$BNALR, hhmmss.ss,xxx,A,A,c-c\*hh<CR><LF>

- hhmmss.ss: This part may be left blank because BNWAS does not include UTC time information.

**Alarm mode: [Legacy]**

-xxx: Designation of source of alarm or source of reset command.

000: Watch alarm normal

010: Communication failure

011: Power failure AC

012: Power failure DC

-A: A=Dormant period exceeded, V=Dormant period not exceeded

-A: A=Alarm acknowledged, V=Alarm unacknowledged

-c--c: BNWAS mode: c1, c2, c3

c1=AUTO, MAN or OFF, c2=Dormant period in min. (03-12),

c3=Alarm stage: 1, 2 or 3

**Alarm mode: [ALERTI/F1]**

-xxx: Designation of source of alarm or source of reset command.

Null: routine transmission(SYSTEM)

000: Watch alarm normal(BNWAS)

001: Power failure DC

002: Power failure AC

250: Malfunction (Communication failure)

-A: A=Dormant period exceeded (BNWAS) or Threshold exceeded (SYSTEM)

V=Dormant period not exceeded (BNWAS) or Threshold not exceeded (SYSTEM)

-A: A=Alarm acknowledged, V=Alarm unacknowledged

-c--c: BNWAS mode: c1, c2, c3

c1=AUTO, MAN or OFF, c2=Dormant period in min. (03-12),

c3=Alarm stage: 1, 2 or 3

SYSTEM mode:text (Null, DC Power Failure, AC Power Failure, COM ERR with Processor Unit)

**Alarm mode: [ALERTI/F2]**

-xxx: Designation of source of alarm or source of reset command.

000: Watch alarm normal

-A: A=Dormant period exceeded, V=Dormant period not exceeded

-A: A=Alarm acknowledged, V=Alarm unacknowledged

-c--c: BNWAS mode: c1, c2, c3

c1=AUTO, MAN or OFF, c2=Dormant period in min. (03-12),

c3=Alarm stage: 1, 2 or 3

Example:

\$BNALR,,000,A,V,C1=AUT;C2=03;C3=1\*hh<CR><LF>

**Proprietary Output Sentences**

Sentence	Sentence construction
PFEC, BNwtr	FEC P sentences Present stage progress of watch alarm timer and setting/remaining time of present stage.
BNmbo	Backup officer and captain backup status

#### 4. INSTALLATION

This page is intentionally left blank.



# APPENDIX 1 MENU TREE, ABBREVIATIONS, JIS CABLE GUIDE

## Menu Tree (default settings in bold italic)

### Administrator menu

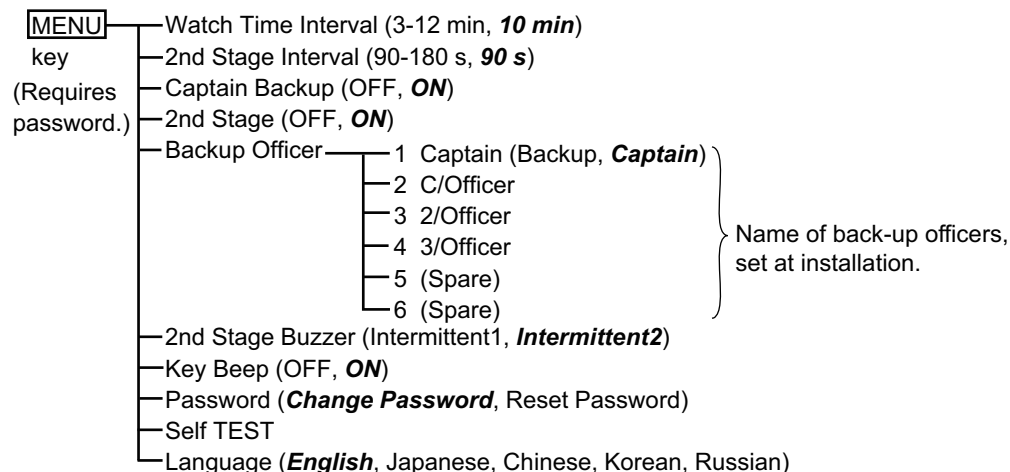

### Service menu

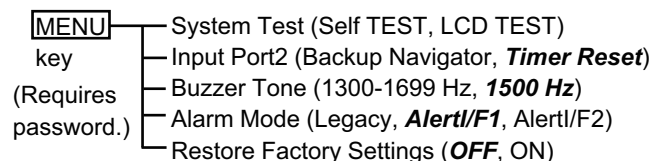

## Abbreviations

Term or Icon	Abbreviation, Meaning	Term or Icon	Abbreviation, Meaning
Alarm	ALARM	Hertz	Hz
Alternating Current	AC	International Maritime Organization	IMO
Automatic	AUTO	Menu	MENU
Bridge Alert Management	BAM	Minimum	MIN
Brilliance	BRILL	Minute	min
Call	CALL	Off	OFF
Communication	COM	Officer Of the Watch	OOW
Counter	CNT	On	ON
Direct Current	DC	Second	s
Electronic Chart Display and Information System	ECDIS	Second stage	2nd stage
Emergency	EMG	Select	SEL
Enter	ENT	Test	TEST
Error	ERR	Third stage	3rd stage
Escape	ESC	Maximum	MAX
First stage	1st stage		Officer call

**JIS Cable Guide**

Cables listed in the manual are usually shown as Japanese Industrial Standard (JIS). Use the following guide to locate an equivalent cable locally.

JIS cable names may have up to 6 alphabetical characters, followed by a dash and a numerical value (example: DPYC-2.5). For core types D and T, the numerical designation indicates the *cross-sectional Area (mm<sup>2</sup>)* of the core wire(s) in the cable. For core types M and TT, the numerical designation indicates the *number of core wires* in the cable.

**1. Core Type**

**D** Double core power line

**T** Triple core power line

**M** 1 mm Multi core

**TT** 0.75mm twisted pair communications (1Q=quad cable)

**2. Insulation Type**

**P** Ethylene Propylene

**Y** Corrosive Resistant

**3. Sheath Type**

**Y** Vinyl

**4. Armor Type**

**C** Steel

**5. Shielding Type**

**Y** Corrosive Resistant

**6. Core Sheath**

**S** All cores in one sheath

**-S** Individually sheathed cores

**SLA** All cores in one sheath, plastic tube sheath w/aluminum tape

**-SLA** Individually sheathed cores, plastic tube sheath w/aluminum tape



DPYC



TPYC

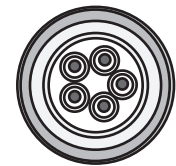

MPYC-5



TTYCS-4

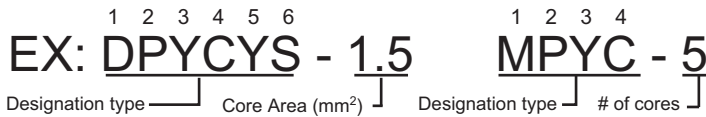











The following reference table lists gives the measurements of JIS cables commonly used with Furuno products:

Type	Core		Cable Diameter	Type	Core		Cable Diameter
	Area	Diameter			Area	Diameter	
DPYC-1.5	1.5mm <sup>2</sup>	1.56mm	11.7mm	TTYC-7S	0.75mm <sup>2</sup>	1.11mm	20.8mm
DPYC-2.5	2.5mm <sup>2</sup>	2.01mm	12.8mm	TTYCSLA-1	0.75mm <sup>2</sup>	1.11mm	9.4mm
DPYC-4	4.0mm <sup>2</sup>	2.55mm	13.9mm	TTYCSLA-1Q	0.75mm <sup>2</sup>	1.11mm	10.8mm
DPYC-6	6.0mm <sup>2</sup>	3.12mm	15.2mm	TTYCSLA-4	0.75mm <sup>2</sup>	1.11mm	15.7mm
DPYCY-2.5	2.5mm <sup>2</sup>	2.01mm	14.8mm	TTYCY-4S	0.75mm <sup>2</sup>	1.11mm	17.9mm
DPYCY-4	4.0mm	2.55mm	15.9mm	TTYCYS-1	0.75mm <sup>2</sup>	1.11mm	12.1mm
DPYCYSLA-1.5	1.5mm <sup>2</sup>	1.56mm	13.9mm	TTYCYS-4	0.75mm <sup>2</sup>	1.11mm	18.5mm
DPYCYSLA-2.5	2.5mm <sup>2</sup>	2.01mm	15.0mm	TPYCY-1.5	1.5mm <sup>2</sup>	1.56mm	14.5mm
MPYC-2	1.0mm <sup>2</sup>	1.29mm	10.0mm	TPYCY-2.5	2.5mm <sup>2</sup>	2.01mm	15.5mm
MPYC-4	1.0mm <sup>2</sup>	1.29mm	11.2mm	TPYCY-4	4.0mm <sup>2</sup>	2.55mm	16.9mm
MPYC-7	1.0mm <sup>2</sup>	1.29mm	13.2mm	TPYCYSLA-1.5	1.5mm <sup>2</sup>	1.56mm	13.9mm
MPYCY-12	1.0mm <sup>2</sup>	1.29mm	19.0mm				
MPYCY-19	1.0mm <sup>2</sup>	1.29mm	22.0mm				

# APPENDIX 2 ALERT ICONS, IDS, MEANINGS AND MEASURES

## Alert icons and their attributes

Icon	Priority level	Alert status	Displayed as	Audible alert
	Alarm	Active - unacknowledged	Red icon and indication flashing at 0.5 second intervals	Three short beeps at seven second intervals.
	Alarm	Active - silenced	Red icon and indication flashing at 0.5 second intervals	OFF
	Alarm	Rectified - unacknowledged	Red icon and indication flashing at 0.5 second intervals	OFF
	Alarm	Active - responsibility transferred	Red icon and indication on steadily	OFF
	Alarm	Active - acknowledged	Red icon and indication on steadily	OFF
	Warning	Active - unacknowledged	Yellow-orange icon and indication flashing at 0.5 second intervals	Two short beeps at four minutes and fifty seconds intervals.
	Warning	Active - silenced	Yellow-orange icon and indication flashing at 0.5 second intervals	OFF
	Warning	Rectified - unacknowledged	Yellow-orange icon and indication flashing at 0.5 second intervals	OFF
	Warning	Active - responsibility transferred	Yellow-orange icon and indication on steadily	OFF
	Warning	Active - acknowledged	Yellow-orange icon and indication on steadily	OFF
	Caution	Active	Yellow icon and indication on steadily	OFF

## Alert priority and category

“Alert” is generic name for a notice to any unusual or potentially dangerous situation generated within the system. The priority of alert are shown with three types of Alarm, Warning and Caution, and the alerts are classified by categories, A or B on this system.

Priority	Description
Alarm	Denote a condition that has to be recognized, or acted upon immediately, for example depth minimum limit exceeded, anchor deep.
Warning	Similar to alarm but need not be acted upon immediately.
Caution	Awareness of a condition with continuous to require attention out of the ordinary consideration of the situation.

**Note:** All active-unacknowledged warnings are repeated as warnings after 4 minutes 50 seconds (manufacturer’s fixed time period).

Category	Description
A	Alert category with additional information for decision support is necessary.
B	Alert where no additional information for decision support is necessary. All alerts are not falling under category A.

**Note:** This system does not have following functions.

- Responsibility transfer
- Functional alert group
- Alert aggregation

Legacy mode alerts, IDs, meanings and measures

ID	Indication	Priority	Meaning	Measures
010	Failure: Communication	Warning	Communication failure between Processor Unit and Main Alarm Panel	Consult a FURUNO technician.
011	Failure: AC	Caution	AC power to the unit is interrupted or stopped.	Check power to unit, check cabling and connections to unit.
012	Failure: DC	Caution	DC power to the unit is interrupted or stopped.	Check power to unit, check cabling and connections to unit.

**Note:** All Legacy mode alerts are assigned category “B” rank.

Alert I/F1 mode alerts, IDs, meanings and measures

ID	Indication	Priority	Category	Meaning	Measures
250	Communication Failure	Warning	B	Communication failure between Processor Unit and Main Alarm Panel.	Consult a FURUNO technician.
001	DC Power Failure	Caution	B	DC power to the unit is interrupted or stopped.	Check power to the unit, check cabling and connections to the unit.
002	AC Power Failure	Caution	B	AC power to the unit is interrupted or stopped.	Check power to the unit, check cabling and connections to the unit.

Alert I/F2 mode alerts, IDs, meanings and measures

ID	Indication	Priority	Category	Meaning	Measures
3062	Communication Failure	Warning	B	Communication failure between Processor Unit and Main Alarm Panel.	Consult a FURUNO technician.
3023-1	DC Power Failure	Caution	B	DC power to the unit is interrupted or stopped.	Check power to the unit, check cabling and connections to the unit.
3023-2	AC Power Failure	Caution	B	AC power to the unit is interrupted or stopped.	Check power to the unit, check cabling and connections to the unit.

## APPENDIX 2 ALERT ICONS, IDS, MEANINGS AND MEASURES

<b>ID</b>	<b>Indication</b>	<b>Priority</b>	<b>Category</b>	<b>Meaning</b>	<b>Measures</b>
3031-1	BNWAS Alarm is 1st Stage	Alarm	B	Watch alarm is at first stage	Press any key on the Main Alarm Panel, or press the Timer Reset Panel button.
3031-2	BNWAS Alarm is 2nd Stage	Alarm	A	Watch alarm is at second stage	Press the <b>RESET</b> key on the Main Alarm Panel.
3031-3	BNWAS Alarm is 3rd Stage	Alarm	A	Watch alarm is at third stage	Press the <b>RESET</b> key on the Main Alarm Panel.

## SPECIFICATIONS OF BRIDGE NAVIGATIONAL WATCH ALARM SYSTEM BR-500

### 1 MAIN ALARM PANEL (BR-510)

- |     |                   |  |
|-----|-------------------|--|
| 1.1 | Display           | 4.3-inch color LCD, 480 x 272 dots   |
| 1.2 | Brilliance        | 0.15 to 500 cd/m <sup>2</sup> (w/o shield film)  |
| 1.3 | Status indication | Dormant period, Alarm stage, Backup officer, Power status, Operation mode*, Active alert list/ Alert log<br>*: Auto operating mode is not available for SOLAS vessels. |
| 1.4 | Other functions   | Backup officer selection, Emergency call, Officer call   |

### 2 PROCESSOR UNIT (BR-520)

- |     |                           |  |
|-----|---------------------------|--|
| 2.1 | Input port                |  |
|     | Operator fitness          | 4 ch (normal open)   |
|     | Autopilot mode            | 1 ch (normal open)   |
|     | Backup navigator          | 1 ch (normal close)  |
| 2.2 | Output port               |  |
|     | System failure            | 2 ch (normal close: legacy mode or normal open: Alert I/F 1 and 2) |
|     | Serial signal             | 1 ch (IEC61162-1)  |
|     | Cabin panel control       | 12 sets max. (3 sets: parallel connection)                         |
|     | Timer reset panel control | 6 sets max. (2 sets: parallel connection)                          |
|     | Motion detector           | 2 ch   |
|     | Flash beacon              | 3 ch   |
| 2.3 | Data sentences            | IEC61162-1 Ed.5  |
|     | Input                     | ACK, ACN, EVE  |
|     | Output                    | ALC, ALF, ALR, ARC, PFEC (BNwtr, BNmbo)                            |

### 3 CABIN PANEL (BR-540, OPTION)

- |     |                        |   |
|-----|------------------------|---|
| 3.1 | Input voltage          | 12 VDC: 100 mA or less (supplied from processor unit) |
| 3.2 | Visible indication     | Alarm LED, Duty LED                                   |
| 3.3 | Audible alarm          | Buzzer  |
| 3.4 | Wire breaking diagnose | Press button  |
| 3.5 | Dimmer                 | Inner volume  |

### 4 TIMER RESET PANEL (BR-530, OPTION)/ WATERTIGHT TIMER RESET PANEL (BR-550, OPTION)

- |     |                        |                                 |
|-----|------------------------|---------------------------------|
| 4.1 | Visible indication     | Alarm LED, Reset LED            |
| 4.2 | Audible alarm          | Buzzer                          |
| 4.3 | Timer reset            | Press button                    |
| 4.4 | Wire breaking diagnose | Continuing pressure of button   |
| 4.5 | Dimmer                 | Inner volume                    |
| 4.6 | Linkage                | Alarm LED linked with key light |

**5 MOTION DETECTOR (BR-560, OPTION)**

- |     |                       |                               |
|-----|-----------------------|-------------------------------|
| 5.1 | Detection method      | Infrared body motion sensor   |
| 5.2 | Distance              | 5 m max.                      |
| 5.3 | Temperature gap       | 7 °C (forward)                |
| 5.4 | Angle                 | ±40°                          |
| 5.5 | Object size           | 700 mm x 250 mm (minimum)     |
| 5.6 | Displacement distance | 1.4 m (5 m forward)           |
| 5.7 | Moving speed          | 0.8 m/s to 1.2 m/s            |
| 5.8 | Signal output         | Contact closure (normal open) |

Note: Above all conditions are required for detection without fail.

**6 FLASH BEACON (BR-570, OPTION)**

- |     |                        |                                       |
|-----|------------------------|---------------------------------------|
| 6.1 | Previous visible alarm | Watch alarm lamp (yellow)             |
| 6.2 | Dimmer                 | External or inner volume              |
| 6.3 | Linkage                | Lamp brilliance linked with key light |

**7 POWER SOURCE**

100-230 VAC: 0.6-0.4 A, 1 phase, 50/60 Hz  
24 VDC: 1.0 A (back-up source)

**8 ENVIRONMENTAL CONDITION**

- |     |   |                                  |
|-----|---|----------------------------------|
| 8.1 | Ambient temperature   |                                  |
|     | Watertight timer reset panel  | -25°C to +55°C                   |
|     | Others  | -15°C to +55°C                   |
| 8.2 | Relative humidity   | 93% at 40°C                      |
| 8.3 | Degree of protection  |                                  |
|     | Processor unit  | IP22 (bulkhead), IP20 (tabletop) |
|     | Main alarm panel, Cabin panel, Timer reset panel, Motion detector, Flash beacon | IP22                             |
|     | Watertight timer reset panel  | IP56                             |
| 8.4 | Vibration   | IEC 60945 Ed.4                   |



**9 COATING COLOR**

- |     |                              |      |
|-----|------------------------------|------|
| 9.1 | Watertight timer reset panel | N1.0 |
| 9.2 | Others                       | N2.5 |

## PACKING LIST

BR-510/BR-510-HK[単体用]

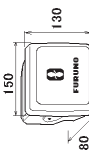
A-1

NAME	OUTLINE	DESCRIPTION/ CODE No.	QTY
ユニット メインアラーム 単体		BR-510/510-HK 000-018-030-00 **	1
工事材料 INSTALLATION MATERIALS			
工事材料		CP24-01701 001-117-860-00 **	1

コード番号末尾の[\*\*]は、選択品の代表コードを表します。  
TRANSDUCER IS PACKED IN SEPARATE BOX.

型式/コード番号が2段の場合、下段より上段に代わる過渡期品であり、どちらが入っています。なお、品質は変わりません。  
TWO TYPES AND CODES MAY BE LISTED FOR AN ITEM. THE LOWER PRODUCT MAY BE SHIPPED IN PLACE OF THE UPPER PRODUCT. QUALITY IS THE SAME.





(略図の寸法は、参考値です。 DIMENSIONS IN DRAWING FOR REFERENCE ONLY.)

C4461-Z01-B

## PACKING LIST

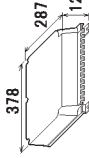
BR-520-J/E-V, BR-520-J/E-HK-V

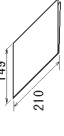
A-2

NAME	OUTLINE	DESCRIPTION/ CODE No.	QTY
ユニット 制御部		BR-520 000-018-041-00 **	1
工事材料 INSTALLATION MATERIALS			
工事材料		CP24-01801 001-138-920-00 **	1
図書 DOCUMENT			
取扱説明書		OM*-44610-* 000-175-603-1* **	1
OPERATOR'S MANUAL			
設定要領		C42-01101-* 000-175-624-1* **	1
HOW TO SHOW SETTING SCREENS			
操作要領書		OS*-44610-* 000-175-622-1* **	1
OPERATOR'S GUIDE			

コード番号末尾の[\*\*]は、選択品の代表コードを表します。  
CODE NUMBER ENDING WITH " \*\*" INDICATES THE CODE NUMBER OF REPRESENTATIVE MATERIAL.

型式/コード番号が2段の場合、下段より上段に代わる過渡期品であり、どちらが入っています。なお、品質は変わりません。  
TWO TYPES AND CODES MAY BE LISTED FOR AN ITEM. THE LOWER PRODUCT MAY BE SHIPPED IN PLACE OF THE UPPER PRODUCT. QUALITY IS THE SAME.

(略図の寸法は、参考値です。 DIMENSIONS IN DRAWING FOR REFERENCE ONLY.)

C4461-Z02-D







## PACKING LIST

BR-520-J/E-10, BR-520-J/E-HK-10

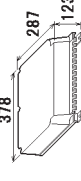
BR-520-J/E-N, BR-520-J/E-HK-N

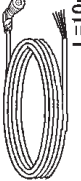
A-4

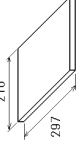
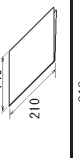
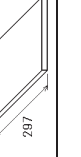
NAME	UNIT	OUTLINE	DESCRIPTION/CODE No.	Q'TY
ユニット				
制御部			BR-520	1
PROCESSOR UNIT			000-018-041-00 **	**
予備品				
予備品			SP24-00501	1
SPARE PARTS			001-117-990-00 **	**
工事材料			CP24-01800	
ケーブル組品			FRU12-05AFFM-10M	1
CABLE ASSEMBLY			001-162-980-10	
工事材料				
INSTALLATION MATERIALS			CP24-01801	1
			001-117-970-00 **	**
図書				
取扱説明書			OM*-44610-*	1
OPERATOR'S MANUAL			000-175-603-1* **	**
設定要領			C42-01101-*	1
HOW TO SHOW SETTING SCREENS			000-175-624-1*	*
操作要領書			OS*-44610-*	1
OPERATOR'S GUIDE			000-175-622-1* **	**

コード番号末尾の[\*]\*\*]は、選択品の代表コードを表します。



CODE NUMBER ENDING WITH "1" OR "2" INDICATES THE CODE NUMBER OF REPRESENTATIVE MATERIAL.

型式/コード番号が2枚の場合、下段より上段に代わる過渡期品であり、どちらが入っています。なお、品質は変わりません。

TWO TYPES AND CODES MAY BE LISTED FOR AN ITEM. THE LOWER PRODUCT MAY BE SHIPPED IN PLACE OF THE UPPER PRODUCT. QUALITY IS THE SAME.

(略図の寸法は、参考値です。 DIMENSIONS IN DRAWING FOR REFERENCE ONLY.)

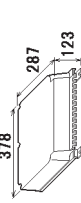
C4461-Z03-F

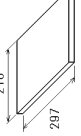
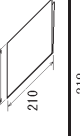
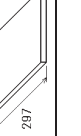
NAME	UNIT	OUTLINE	DESCRIPTION/CODE No.	Q'TY
ユニット				
制御部			BR-520	1
PROCESSOR UNIT			000-018-041-00 **	**
予備品				
予備品			SP24-00501	1
SPARE PARTS			001-117-990-00 **	**
工事材料				
INSTALLATION MATERIALS			CP24-01801	1
			001-117-970-00 **	**
図書				
取扱説明書			OM*-44610-*	1
OPERATOR'S MANUAL			000-175-603-1* **	**
設定要領			C42-01101-*	1
HOW TO SHOW SETTING SCREENS			000-175-624-1*	*
操作要領書			OS*-44610-*	1
OPERATOR'S GUIDE			000-175-622-1* **	**

コード番号末尾の[\*]\*\*]は、選択品の代表コードを表します。

CODE NUMBER ENDING WITH "1" OR "2" INDICATES THE CODE NUMBER OF REPRESENTATIVE MATERIAL.

型式/コード番号が2枚の場合、下段より上段に代わる過渡期品であり、どちらが入っています。なお、品質は変わりません。

TWO TYPES AND CODES MAY BE LISTED FOR AN ITEM. THE LOWER PRODUCT MAY BE SHIPPED IN PLACE OF THE UPPER PRODUCT. QUALITY IS THE SAME.





(略図の寸法は、参考値です。 DIMENSIONS IN DRAWING FOR REFERENCE ONLY.)

C4461-Z04-D

## PACKING LIST

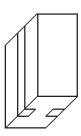
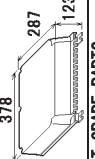
BR-510/520-E-10

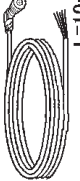
A-5

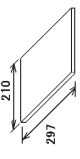
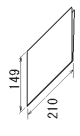
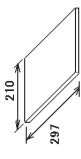
NAME	OUTLINE	DESCRIPTION/ CODE No.	QTY
<b>ユニット</b> メインアラーム 制御式 MAIN ALARM PANEL		BR-510 000-020-271-00	1
制御部 PROCESSOR UNIT		BR-520 000-018-041-00	1
<b>制御部予備品</b> 予備品 SPARE PARTS		SP24-00501 001-117-990-00	1
<b>制御部工材</b> ケーブル組品 CABLE ASSEMBLY		FRU12-05AFEM-10M 001-162-980-10	1
工事材料 INSTALLATION MATERIALS		CP24-01801 001-117-970-00	1
<b>図書</b> 取扱説明書 OPERATOR'S MANUAL		OME-44610-* 000-175-608-1*	1
設定要領 HOW TO SHOW SETTING SCREENS		C42-01101-* 000-175-624-1*	1
操作要領書 OPERATOR'S GUIDE		OSE-44610-* 000-175-619-1*	1

型式・コード番号が2段の場合、下段より上段に代わる過渡期品であり、どちらかが入っています。なお、品質は変わりません。  
TWO TYPES AND CODES MAY BE LISTED FOR AN ITEM. THE LOWER PRODUCT MAY BE SHIPPED IN PLACE OF THE UPPER PRODUCT. QUALITY IS THE SAME.

(略図の寸法は、参考値です。 DIMENSIONS IN DRAWING FOR REFERENCE ONLY.)



JP

C4461-Z05-G

## PACKING LIST

BR-510/520-E-N

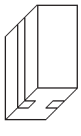
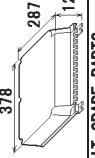
A-6

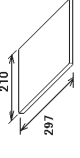
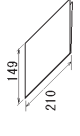
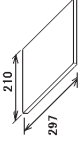
NAME	OUTLINE	DESCRIPTION/ CODE No.	QTY
<b>ユニット</b> メインアラーム 制御式 MAIN ALARM PANEL		BR-510 000-020-271-00	1
制御部 PROCESSOR UNIT		BR-520 000-018-041-00	1
<b>制御部予備品</b> 予備品 SPARE PARTS		SP24-00501 001-117-990-00	1
<b>制御部工材</b> 工事材料 INSTALLATION MATERIALS		CP24-01801 001-117-970-00	1
<b>図書</b> 取扱説明書 OPERATOR'S MANUAL		OME-44610-* 000-175-608-1*	1
設定要領 HOW TO SHOW SETTING SCREENS		C42-01101-* 000-175-624-1*	1
操作要領書 OPERATOR'S GUIDE		OSE-44610-* 000-175-619-1*	1

型式・コード番号が2段の場合、下段より上段に代わる過渡期品であり、どちらかが入っています。なお、品質は変わりません。  
TWO TYPES AND CODES MAY BE LISTED FOR AN ITEM. THE LOWER PRODUCT MAY BE SHIPPED IN PLACE OF THE UPPER PRODUCT. QUALITY IS THE SAME.

(略図の寸法は、参考値です。 DIMENSIONS IN DRAWING FOR REFERENCE ONLY.)

JP

C4461-Z06-E

CODE NO.	001-117-860-00 **	24AJ-X-9401-1	1/1
TYPE	CP24-01701		

**工事材料表**

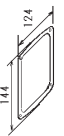
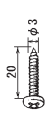
BR-510		INSTALLATION MATERIALS		BR-520	
番号 NO.	名称 NAME	略図 OUTLINE	型名/規格 DESCRIPTIONS	数量 Q'TY	用途/備考 REMARKS
1	F_MOUNT CUSHION F_MOUNT CUSHION		20-032-1064-I CODE NO. 100-357-181-10	1	
2	コハネツガ SELF-TAPPING SCREW		3X20 SUS304 CODE NO. 000-165-884-10	4	

コード番号末尾の「\*\*」は、選択品の代表コードを表します。  
 CODE NUMBER ENDING WITH “\*\*” INDICATES THE CODE NUMBER OF REPRESENTATIVE MATERIAL.  
 型式/コード番号が2段の場合、下段より上段に代わる選定部品であり、どちらが入っています。なお、品質は変わりません。  
 TWO TYPES AND CODES MAY BE LISTED FOR AN ITEM. THE LOWER PRODUCT MAY BE SHIPPED IN PLACE OF THE UPPER PRODUCT.  
 QUALITY IS THE SAME. DIMENSIONS IN DRAWING FOR REFERENCE ONLY.)  
 (略図の寸法は、参考値です。)

CODE NO.	001-117-970-00	24AJ-X-9404-2	1/1
TYPE	CP24-01801		

**工事材料表**

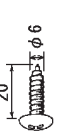
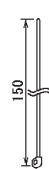
BR-520		INSTALLATION MATERIALS		BR-520	
番号 NO.	名称 NAME	略図 OUTLINE	型名/規格 DESCRIPTIONS	数量 Q'TY	用途/備考 REMARKS
1	セルフタッピングビス SELF-TAPPING SCREW		GX20 SUS304 CODE NO. 000-162-619-10	4	
2	コハネツガ CABLE TIE		CY-1508 CODE NO. 000-167-183-10	30	

型式/コード番号が2段の場合、下段より上段に代わる選定部品であり、どちらが入っています。なお、品質は変わりません。  
 TWO TYPES AND CODES MAY BE LISTED FOR AN ITEM. THE LOWER PRODUCT MAY BE SHIPPED IN PLACE OF THE UPPER PRODUCT.  
 QUALITY IS THE SAME. DIMENSIONS IN DRAWING FOR REFERENCE ONLY.)  
 (略図の寸法は、参考値です。)



表 1 TABLE 1

寸法区分 (mm) DIMENSION	公差 (mm) TOLERANCE
L ≤ 50	±1.5
50 < L ≤ 100	±2.5
100 < L ≤ 500	±3

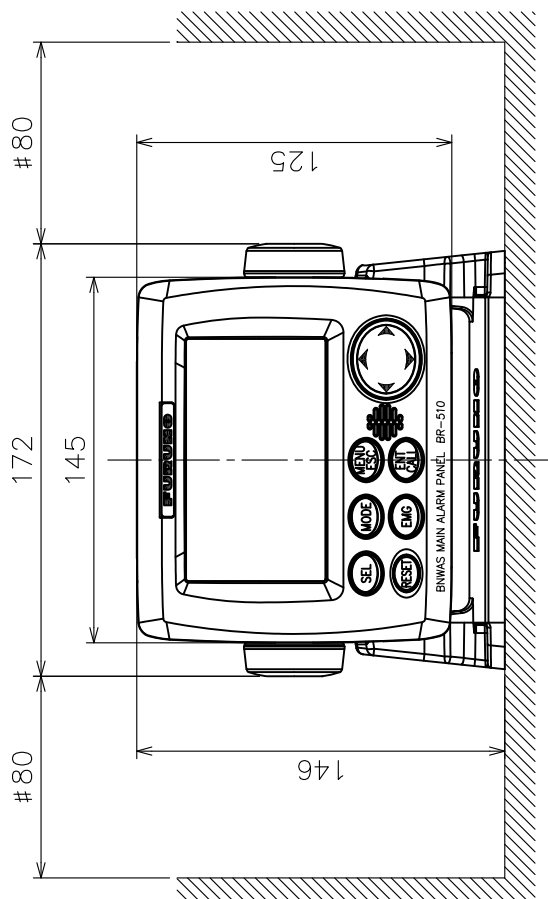
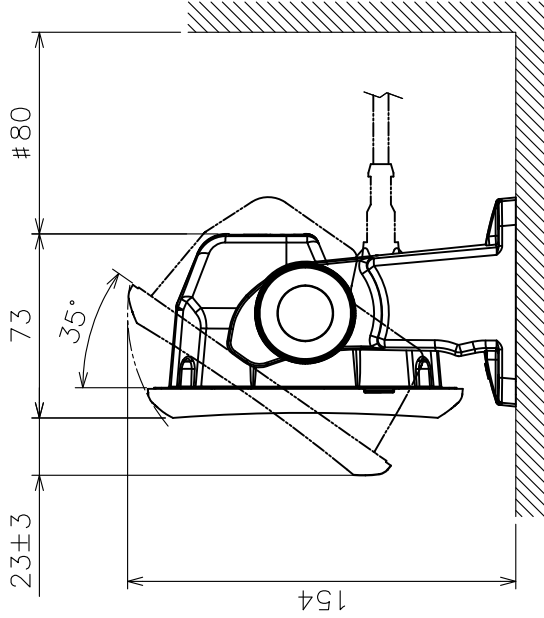
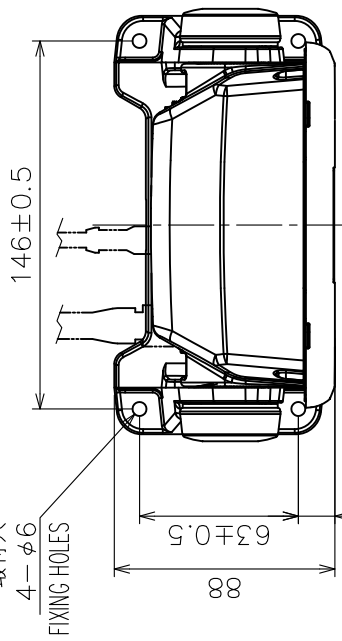
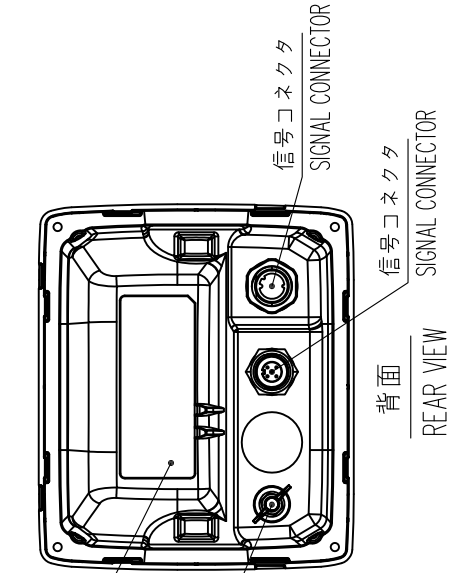

注 記

- 1) 指定外寸公差は表 1 による。
- 2) # 印寸法は、最小サービスイ間寸法とする。
- 3) 取付用ネジはトラスタップピンネジ呼び径5×20を使用のこと。

NOTE

1. TABLE 1 INDICATES TOLERANCE OF DIMENSIONS WHICH IS NOT SPECIFIED.
2. # MINIMUM SERVICE CLEARANCE.
3. USE TAPPING SCREWS φ5x20 FOR FIXING THE UNIT.

DRAWN	4/Oct/2011	T.YAMASAKI	TITLE	BR-510
CHECKED	4/Oct/2011	H.MAKI	名称	メインアラームパネル (卓上装備)
APPROVED	6/Oct/2011	Y.NISHIYAMA	外寸図	
SCALE	1/3	質量 0.70 kg ±0% 質量はケーブルを含まず。 MASS DOES NOT INCLUDE CABLE.	NAME	MAIN ALARM PANEL (TABLETOP MOUNT)
DWG.No.	C4461-G01-C	REF.No.	24-012-100G-5	OUTLINE DRAWING

表 1 TABLE 1

寸法区分 (mm) DIMENSION	公差 (mm) TOLERANCE
L ≤ 50	±1.5
50 < L ≤ 100	±2.5
100 < L ≤ 500	±3

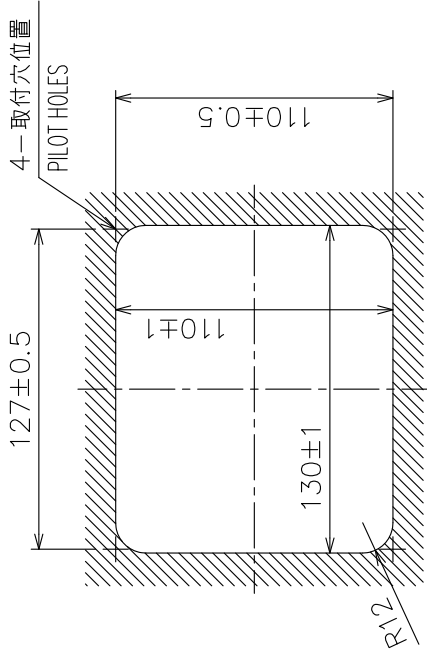

取付穴寸法図  
CUTOUT DIMENSIONS

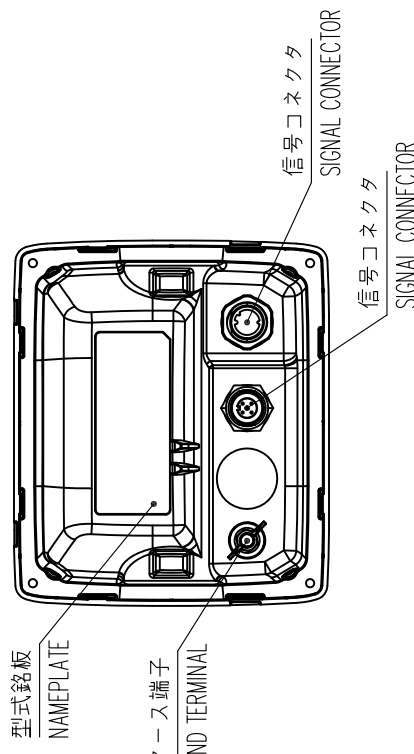
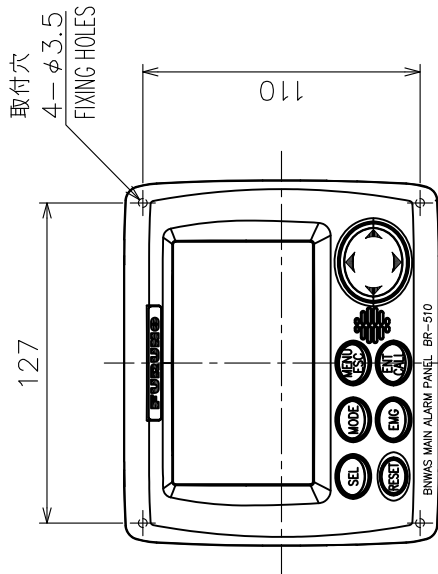
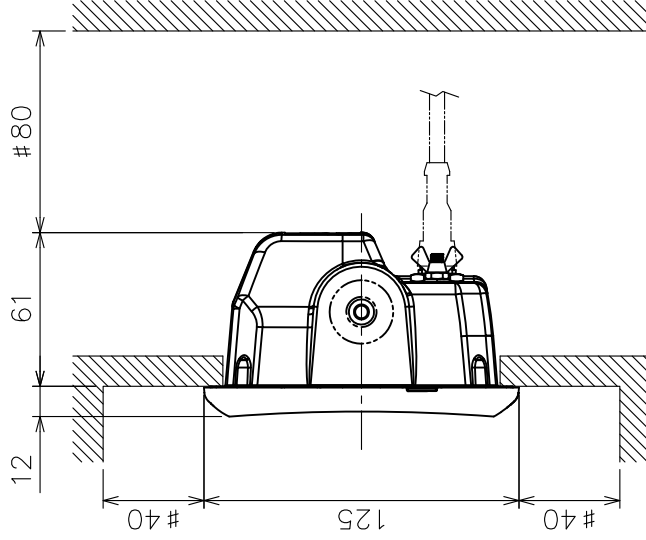

注 記

- 1) 指定外寸法公差は表 1 による。
- 2) #印寸法は、最小サービス空間寸法とする。
- 3) 取付用ネジはナベタツピンネジ呼び径 3 × 2.0 を使用のこと。

NOTE

1. TABLE 1 INDICATES TOLERANCE OF DIMENSIONS WHICH IS NOT SPECIFIED.
2. # MINIMUM SERVICE CLEARANCE.
3. USE TAPPING SCREWS  $\phi 3 \times 2.0$  FOR FIXING THE UNIT.

DRAWN	4/Oct/2011	T.YAMASAKI	TITLE	BR-510
CHECKED	4/Oct/2011	H.MAKI	名称	メインアラームパネル (埋込装備)
APPROVED	6/Oct/2011	Y.NISHIYAMA	外寸図	
SCALE	1/3	質量はケーブルを含みます。 #印寸法はケーブルを含みません。 MASS DOES NOT INCLUDE CABLE.	NAME	MAIN ALARM PANEL (FLUSH MOUNT)
DWG.No.	C4461-G02-C	REF.No.	24-012-110G-5	OUTLINE DRAWING

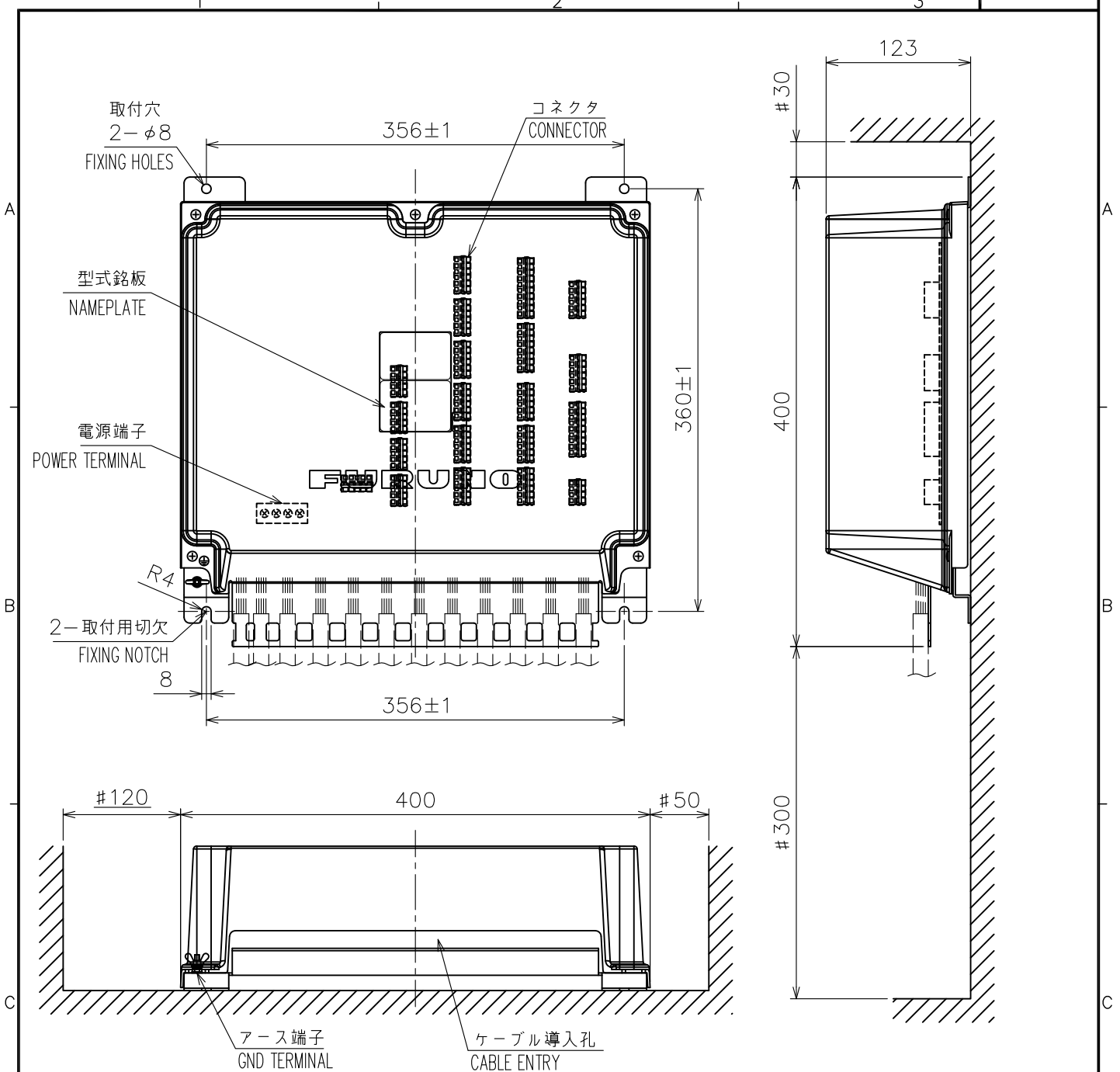

注 記

- 1) #印寸法は最小サービス空間寸法とする。
- 2) 指定外の寸法公差は表1による。
- 3) 取付はM6ボルトまたはトラスタッピンネジ呼び径6×20を使用のこ。

NOTE

1. TABLE 1 INDICATES TOLERANCE OF DIMENSIONS WHICH IS NOT SPECIFIED.
2. #: MINIMUM SERVICE CLEARANCE.
3. USE M6 BOLTS OR TAPPING SCREWS  $\phi 6 \times 20$  FOR FIXING THE UNIT.

表 1 TABLE 1

寸法区分 (mm) DIMENSION	公差 (mm) TOLERANCE
$L \leq 50$	$\pm 1.5$
$50 < L \leq 100$	$\pm 2.5$
$100 < L \leq 500$	$\pm 3$

DRAWN 9/Feb/2011 T.YAMASAKI	TITLE BR-520
CHECKED 9/Feb/2011 H.MAKI	名称 制御部 (壁掛装備)
APPROVED 9/Feb/2011 Y.NISHIYAMA	BR-500 外寸図
SCALE 1/5	NAME PROCESSOR UNIT (BULKHEAD MOUNT)
MASS 5.3 $\pm 10\%$ kg	OUTLINE DRAWING
DWG.No. C4461-G03-C	REF.No. 24-012-200G-3



表 1 TABLE 1

寸法区分 (mm) DIMENSION	公差 (mm) TOLERANCE
L ≤ 50	±1.5
50 < L ≤ 100	±2.5
100 < L ≤ 500	±3

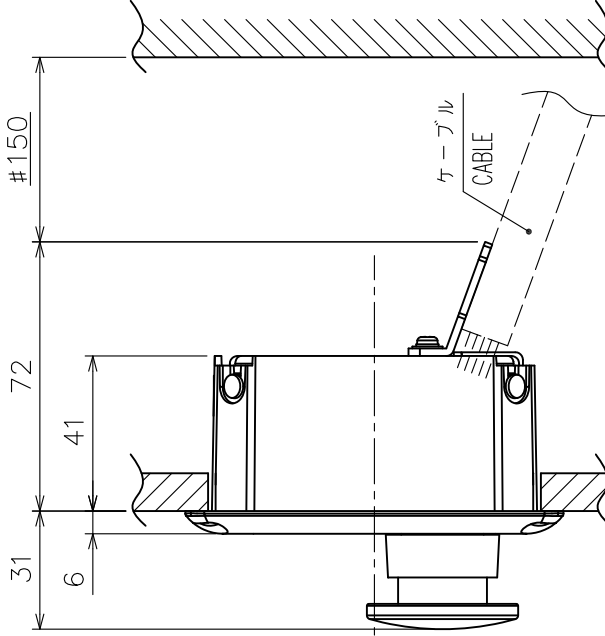
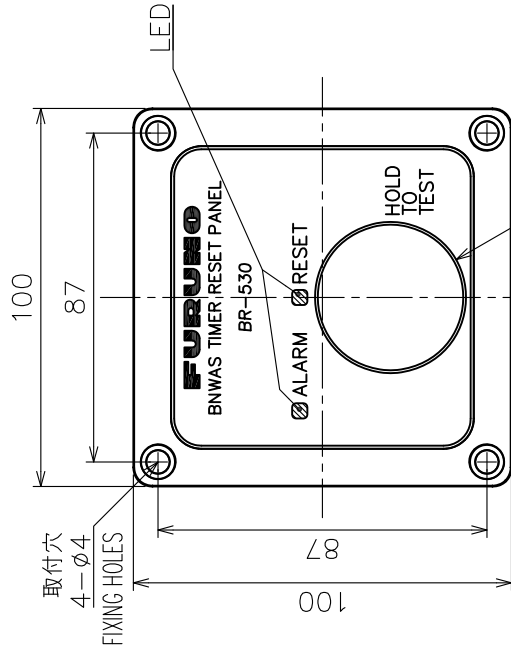
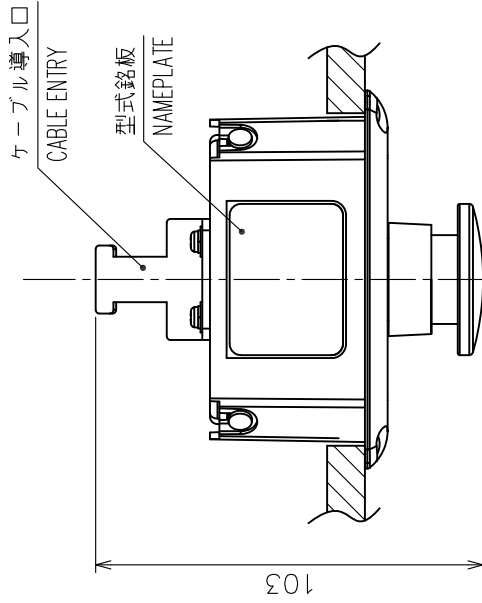
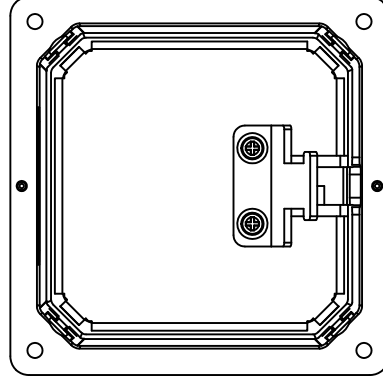
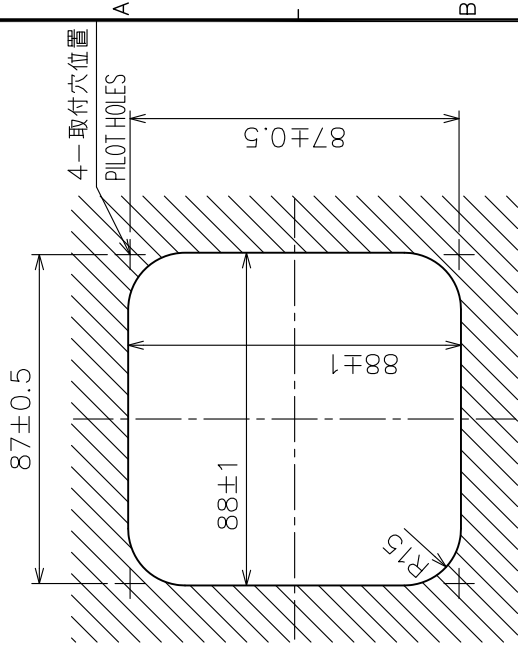

## 注 記

- 1) 指定外の寸法公差は表 1 による。
- 2) # 印寸法は最小サービス空間寸法とする。
- 3) 取り付けは、バインドタッピング径φ3×16を使用のこと。

## NOTE

1. TABLE 1 INDICATES TOLERANCE OF DIMENSIONS WHICH IS NOT SPECIFIED.
2. # MINIMUM SERVICE CLEARANCE.
3. USE BIND TAPPING SCREWS φ3x16 FOR FIXING THE UNIT.

DRAWN	4/Oct/2011	T.YAMASAKI	TITLE	BR-530
CHECKED	4/Oct/2011	H.MAKI	名称	タイマーリセットパネル (埋込装備)
APPROVED	6/Oct/2011	Y.NISHIYAMA	外寸図	
SCALE	1/2	質量はケーブルを含まず。 MASS DOES NOT INCLUDE CABLE.	NAME	TIMER RESET PANEL (FLUSH MOUNT)
DWG.No.	C4461-604-D	REF.No.	24-012-300G-5	OUTLINE DRAWING



表 1 TABLE 1

寸法区分 (mm) DIMENSION	公差 (mm) TOLERANCE
L ≤ 50	±1.5
50 < L ≤ 100	±2.5
100 < L ≤ 500	±3

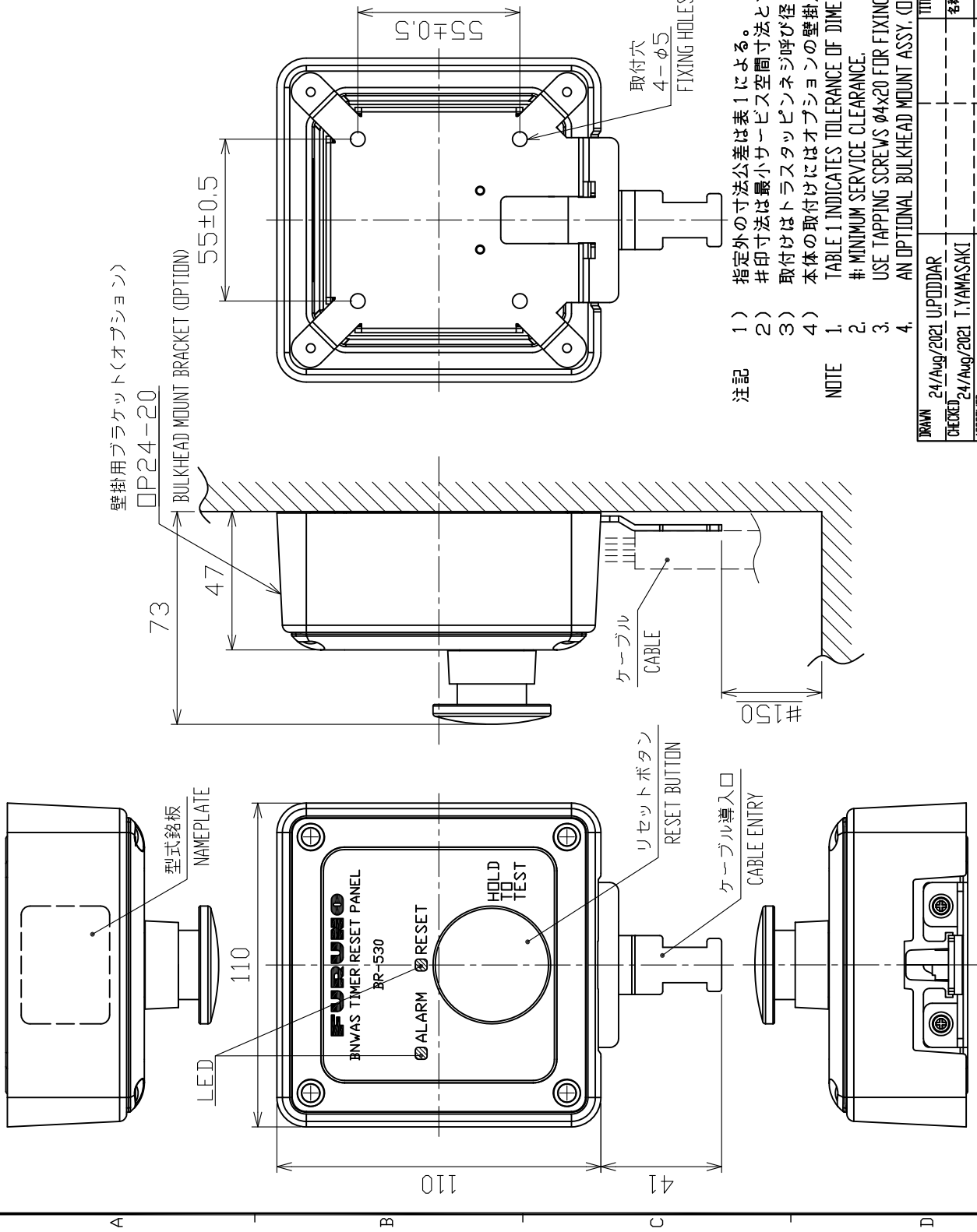

- 注記
- 1) 指定外の寸法公差は表 1 による。
  - 2) #印寸法は最小サービスペース寸法とする。
  - 3) 取付けはトラスタツピンネジ呼び径 4×20 を使用のこと。
  - 4) 本体の取付けにはオプションの壁掛用ブラケット (DP24-20) が別途必要です。
- NOTE
1. TABLE 1 INDICATES TOLERANCE OF DIMENSIONS WHICH IS NOT SPECIFIED.
  2. # MINIMUM SERVICE CLEARANCE.
  3. USE TAPPING SCREWS  $\phi 4 \times 20$  FOR FIXING THE UNIT.
  4. AN OPTIONAL BULKHEAD MOUNT ASSY. (DP24-20) REQUIRED FOR FIXING THE UNIT.

DRAWN	24/Aug/2021	UPDDAR	TITLE	BR-530
CHECKED	24/Aug/2021	T.YAMASAKI	名称	タイマーリセットパネル (壁掛装備)
APPROVED	26/Aug/2021	H.MAKI	外寸図	
SCALE	1/2	質量はケーブルを含む。 #印寸法はケーブルを含まず。 MASS DOES NOT INCLUDE CABLE.	NAME	TIMER RESET PANEL (BULKHEAD MOUNT)
DWG.No.	C4461-G05-E	24-012-310G-6	OUTLINE DRAWING	



表 1 TABLE 1

寸法区分 (mm) DIMENSION	公差 (mm) TOLERANCE
L ≤ 50	±1.5
50 < L ≤ 100	±2.5
100 < L ≤ 500	±3

壁掛用ブラケット(オプション)  
OP24-20

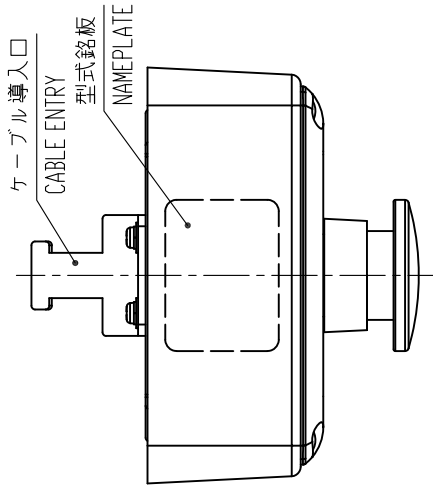
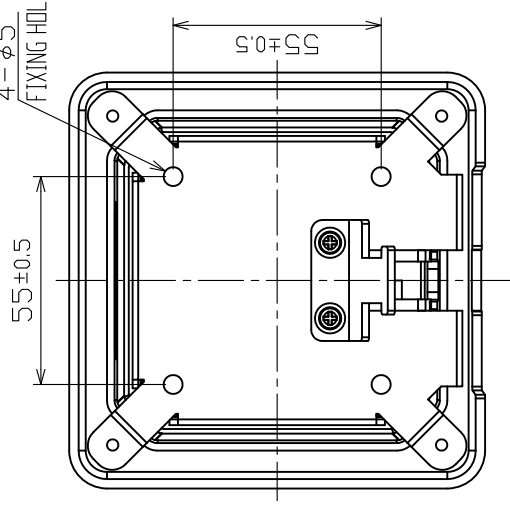
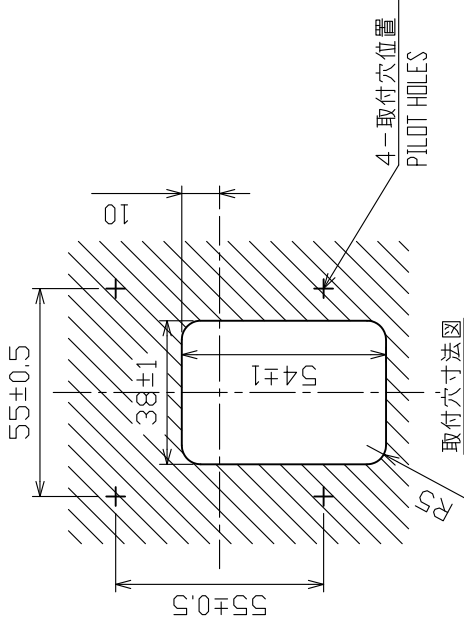
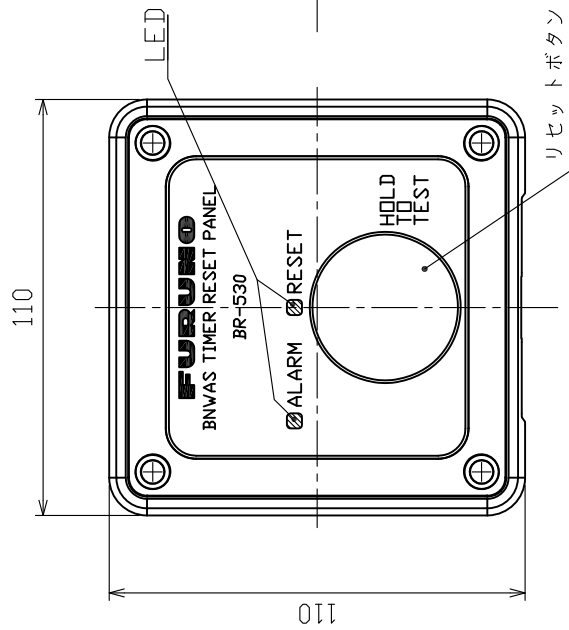
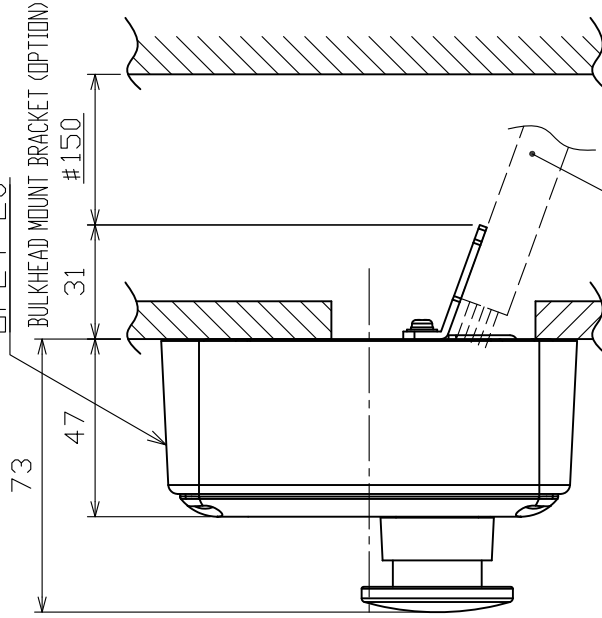

- 注記
- 1) 指定外の寸法公差は表 1 による。
  - 2) # 印寸法は最小サービスイ間寸法とする。
  - 3) 取り付けはトラスタップネジ呼び径 4×20 を使用のこと。
  - 4) 本体の取り付けにはオプションの壁掛用ブラケット(OP24-20)が別途必要です。
- NOTE
1. TABLE 1 INDICATES TOLERANCE OF DIMENSIONS WHICH IS NOT SPECIFIED.
  2. # MINIMUM SERVICE CLEARANCE.
  3. USE TAPPING SCREWS φ4×20 FOR FIXING THE UNIT.
  4. AN OPTIONAL BULKHEAD MOUNT ASSY. (OP24-20) REQUIRED FOR FIXING THE UNIT.

DRAWN	26/Aug/2021	U.PODDAR	TITLE	BR-530
CHECKED	26/Aug/2021	T.YAMASAKI	各称	タイマーリセットパネル (壁掛装備)
APPROVED	27/Aug/2021	H.MAKI	外寸図	
SCALE	1/2	1 MASS 0.33 30% 質量はケーブルを含みます。 MASS DOES NOT INCLUDE CABLE.	NAME	TIMER RESET PANEL (BULKHEAD MOUNT)
FIG.No.	C4461-006-E	REF.No.	24-012-31G-5	OUTLINE DRAWING



表 1 TABLE 1

寸法区分 (mm) DIMENSION	公差 (mm) TOLERANCE
L ≤ 50	±1.5
50 < L ≤ 100	±2.5
100 < L ≤ 500	±3

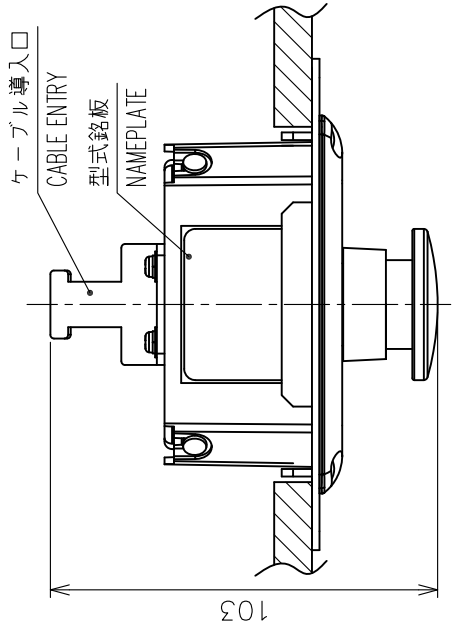
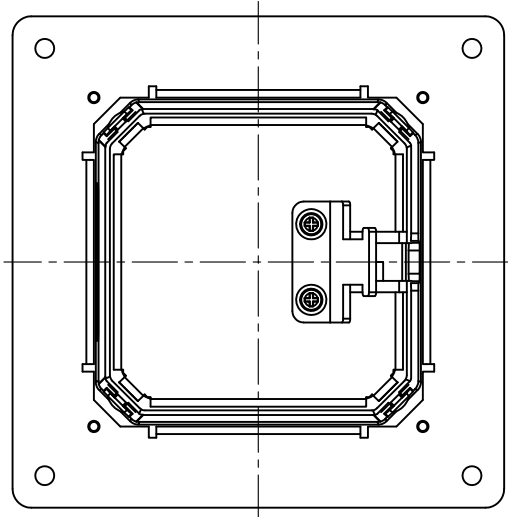
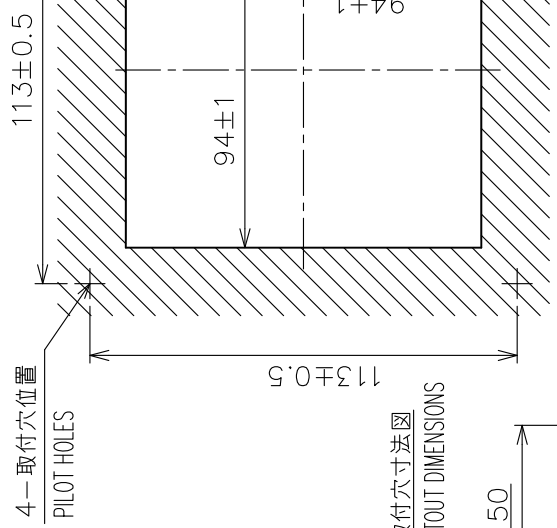
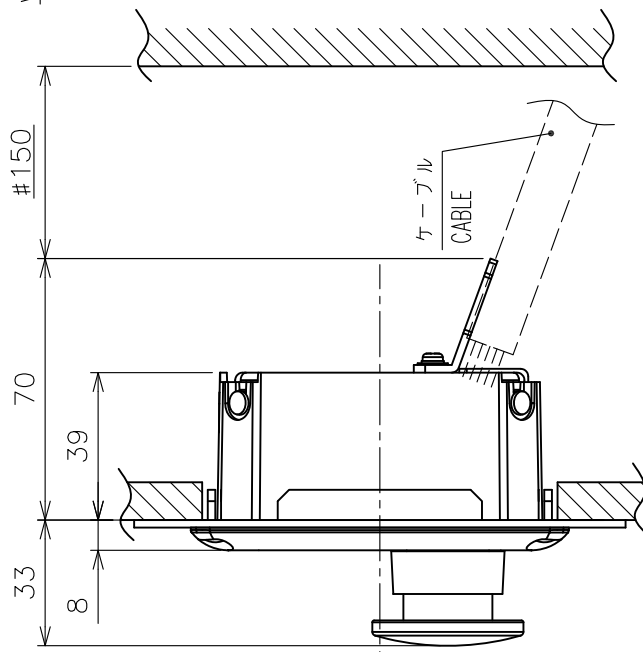
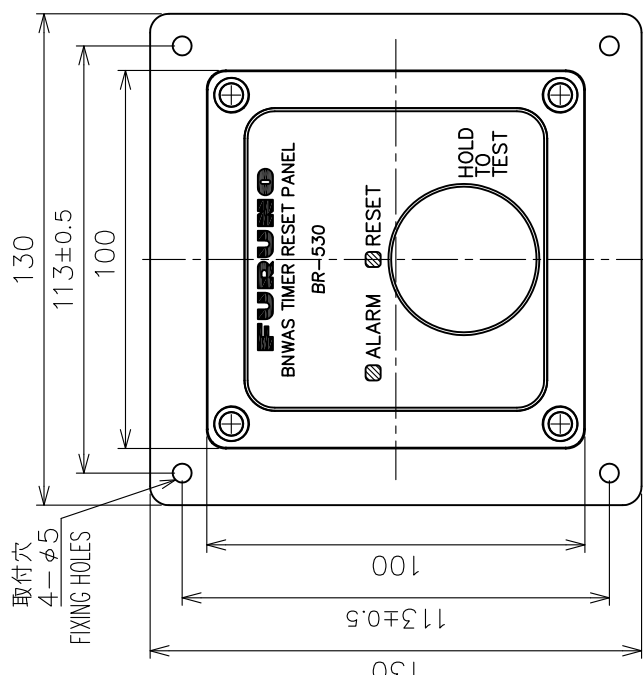

- 注 記
- 1) 指定外の寸法公差は表 1 による。
  - 2) # 印寸法は最小サービス空間寸法とする。
  - 3) 取付けは、トラスタップピンネジ呼び径 4 × 1.6 を使用のこと。
- NOTE
1. TABLE 1 INDICATES TOLERANCE OF DIMENSIONS WHICH IS NOT SPECIFIED.
  2. # : MINIMUM SERVICE CLEARANCE.
  3. USE TAPPING SCREWS φ4x1.6 FOR FIXING THE UNIT.

DRAWN	20/Jun/2012	I.YAMASAKI	TITLE	BR-530
CHECKED	20/Jun/2011	H.IMAKI	名称	タイマーリセットパネル (埋込装備)
APPROVED	20/Jun/2012	Y.NISHIYAMA	外寸図	
SCALE	1/2	質量はケーブルを含まず #100 MASS DOES NOT INCLUDE CABLE.	NAME	TIMER RESET PANEL (FLUSH MOUNT)
DWG.No.	C4461-G17-A	REF.No.	24-012-330G-1	OUTLINE DRAWING



表 1 TABLE 1

寸法区分 (mm) DIMENSION	公差 (mm) TOLERANCE
$L \leq 50$	$\pm 1.5$
$50 < L \leq 100$	$\pm 2.5$
$100 < L \leq 500$	$\pm 3$

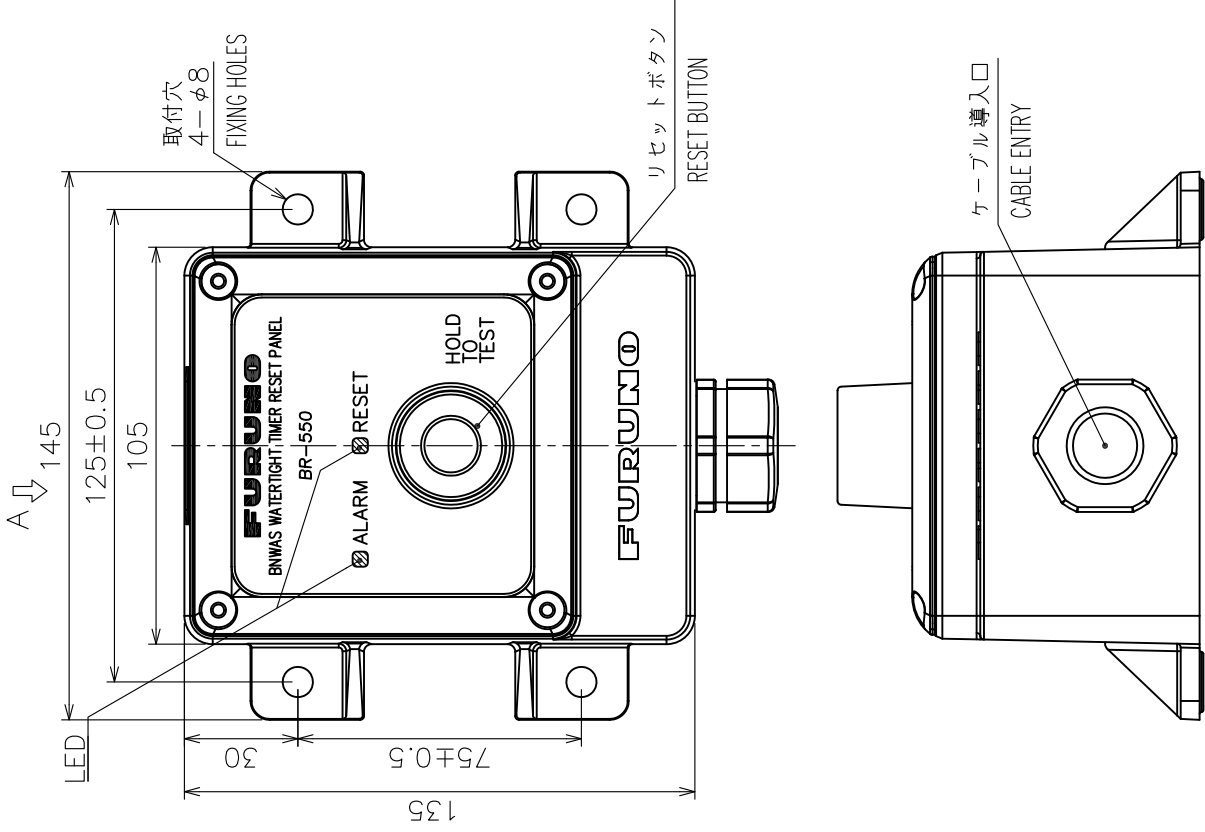
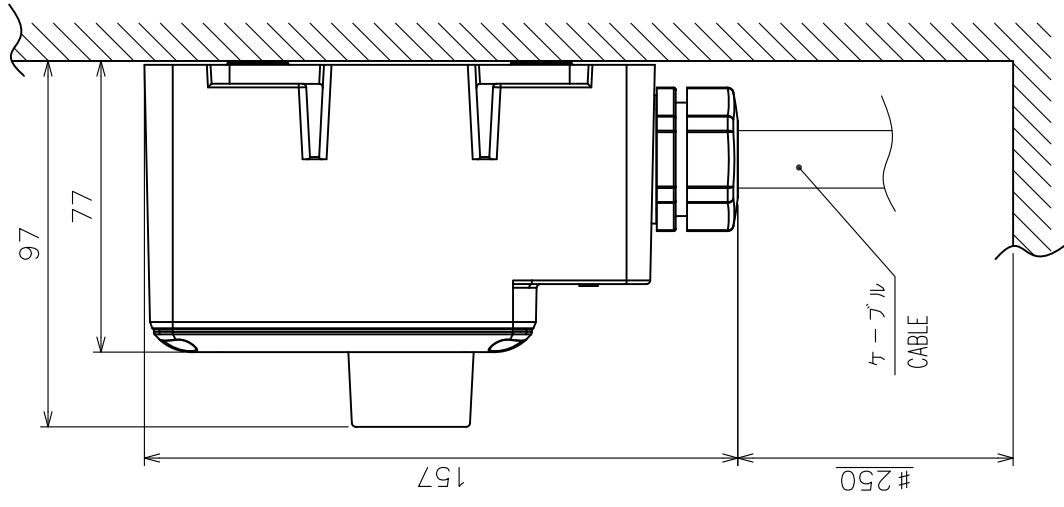

矢視 A  
VIEW A

- 注 記
- 1) 指定外の寸法公差は表 1 による。
  - 2) #印寸法は最小サージスペース寸法とする。
  - 3) 取付用ネジはトラスタップピンネジ呼び径  $6 \times 30$  を使用のこと。

- NOTE
1. TABLE 1 INDICATES TOLERANCE OF DIMENSIONS WHICH IS NOT SPECIFIED.
  2. # MINIMUM SERVICE CLEARANCE.
  3. USE TAPPING SCREWS  $\phi 6 \times 30$  FOR FIXING THE UNIT.

DRAWN	8/Mar/2011	T. YAMASAKI	TITLE	BR-550
CHECKED	8/Mar/2011	H. MAKI	名称	防水タイマーリセットパネル (壁掛装備)
APPROVED	9/Mar/2011	Y. NISHIYAMA	外寸図	
SCALE	1/2	質量はケーブルを含みます。 ±0% 質量はケーブルを含まず。 kg MASS DOES NOT INCLUDE CABLE.	NAME	WATER TIGHT TIMER RESET PANEL
DWG.No.	C4461-G07-E	REF.No.	24-012-320G-5	OUTLINE DRAWING

表 1 TABLE 1

寸法区分 (mm) DIMENSION	公差 (mm) TOLERANCE
L ≤ 50	±1.5
50 < L ≤ 100	±2.5
100 < L ≤ 500	±3

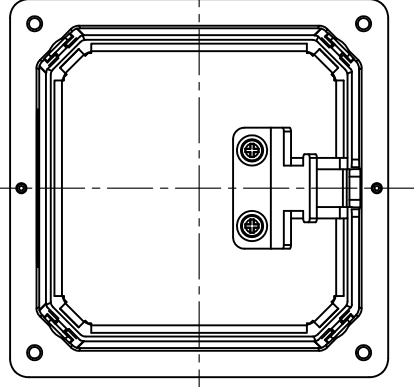
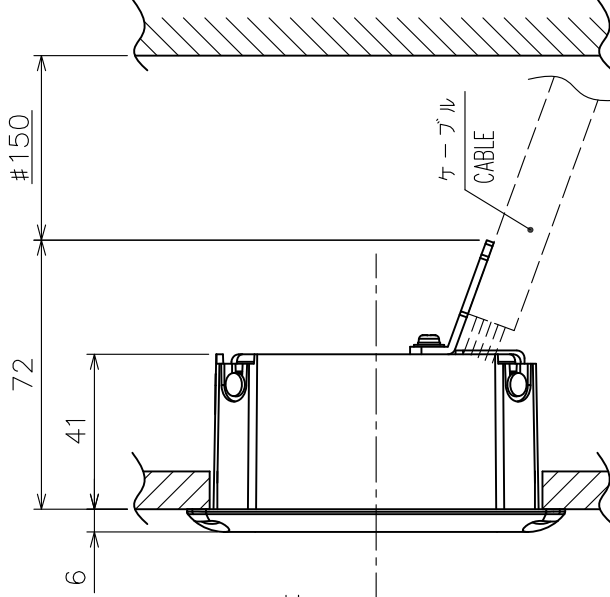
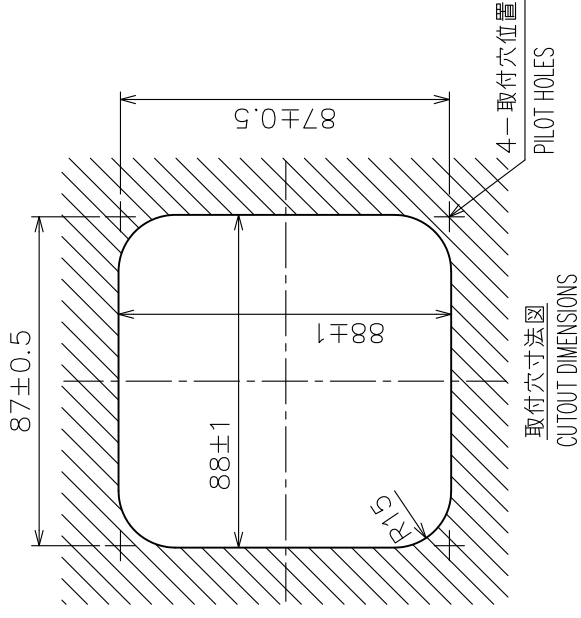
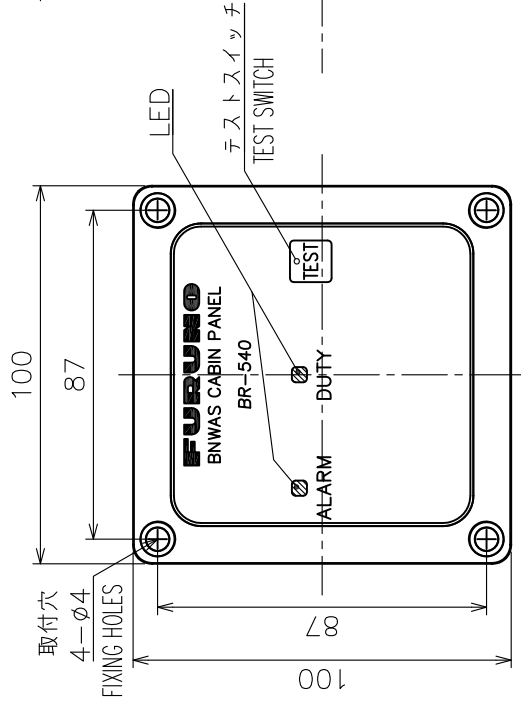
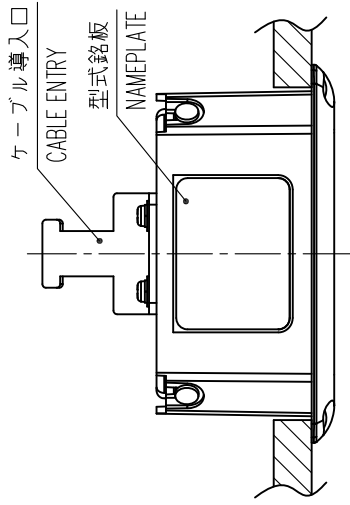

- 注記 1) 指定外の寸法公差は表 1 による。  
 2) # 印寸法は最小サービスクリアランスとする。  
 3) 取り付けは、バインドット呼びネジ呼び径 3 × 16 を使用のこと。
- NOTE 1. TABLE 1 INDICATES TOLERANCE OF DIMENSIONS WHICH IS NOT SPECIFIED.  
 2. #: MINIMUM SERVICE CLEARANCE.  
 3. USE BIND TAPPING SCREWS φ3x16 FOR FIXING THE UNIT.

DRAWN	4/Oct/2011	T.YAMASAKI	TITLE	BR-540
CHECKED	4/Oct/2011	H.MAKI	名称	キャビンパネル (埋込装備)
APPROVED	6/Oct/2011	Y.NISHIYAMA	外寸図	
SCALE	1/2	質量はケーブルを含みます。 #印寸法はケーブルを含みません。 MASS DOES NOT INCLUDE CABLE.	NAME	CABIN PANEL (FLUSH MOUNT)
DWG.No.	C4461-G08-C	REF.No.	24-012-400G-5	OUTLINE DRAWING

表 1 TABLE 1

寸法区分 (mm) DIMENSION	公差 (mm) TOLERANCE
L ≤ 50	±1.5
50 < L ≤ 100	±2.5
100 < L ≤ 500	±3

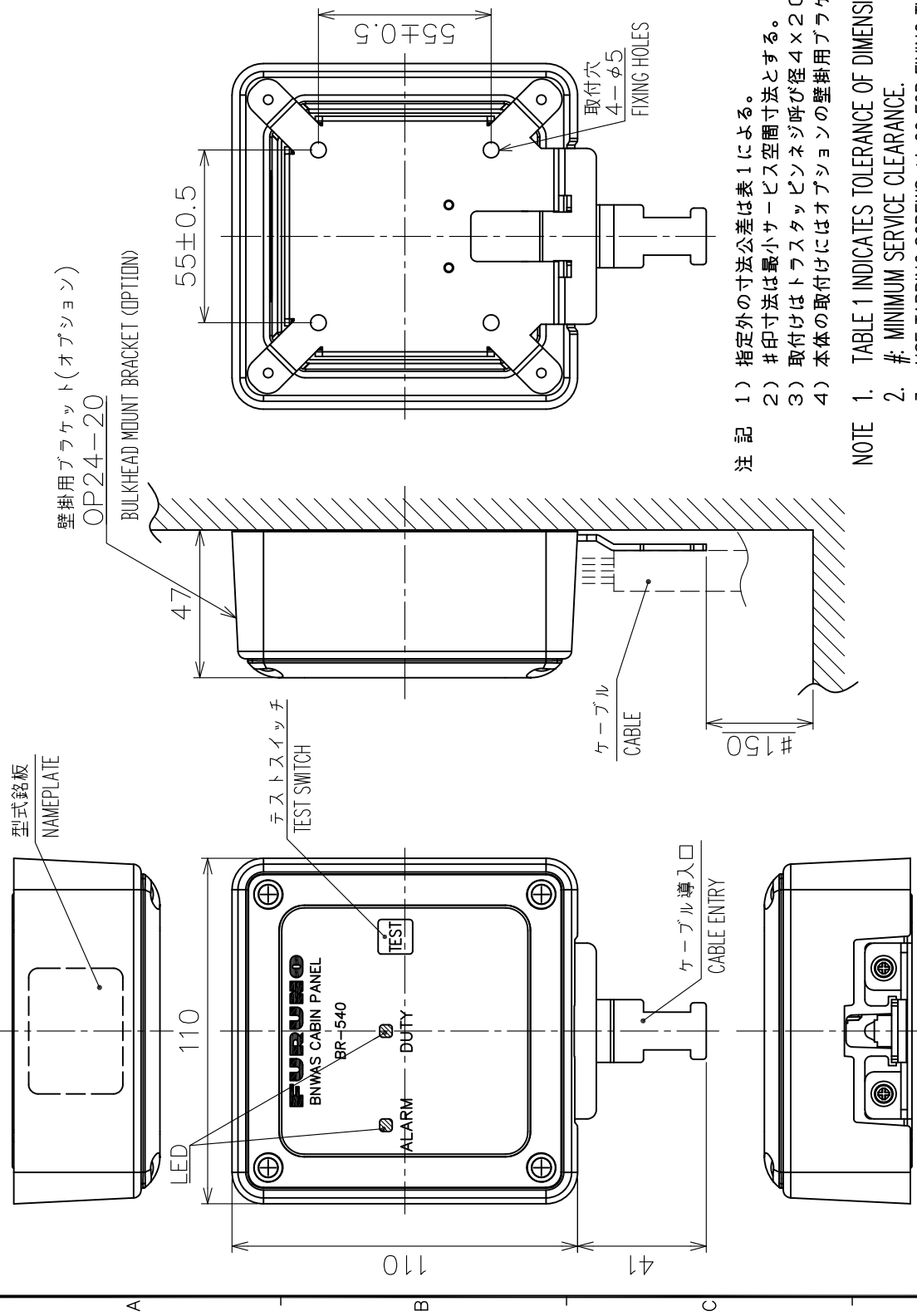

- 注 記
- 1) 指定外の寸法公差は表 1 による。
  - 2) # 印寸法は最小サービス空間寸法とする。
  - 3) 取付けはトラススタップネジ呼び径 4×20 を使用のこと。
  - 4) 本体の取付けにはオプションの壁掛用ブラケット(OP24-20)が別途必要です。

- NOTE
1. TABLE 1 INDICATES TOLERANCE OF DIMENSIONS WHICH IS NOT SPECIFIED.
  2. #: MINIMUM SERVICE CLEARANCE.
  3. USE TAPPING SCREWS  $\phi 4 \times 20$  FOR FIXING THE UNIT.
  4. AN OPTIONAL BULKHEAD MOUNT ASSY. (OP24-20) REQUIRED FOR FIXING THE UNIT.

DRAWN	24/Aug/2021 U.PODDAR	TITLE	BR-540
CHECKED	24/Aug/2021 T.YAMASAKI	名称	キャビンパネル (壁掛装備)
APPROVED	27/Aug/2021 H.MAKI	外寸図	
SCALE	1/2	質量はケーブルを含む。 MASS DOES NOT INCLUDE CABLE.	
DWG.No.	C4461-G09-D	REF.No.	24-012-410G-6
		NAME	CABIN PANEL (BULKHEAD MOUNT)
		OUTLINE DRAWING	

表 1 TABLE 1

寸法区分 (mm) DIMENSION	公差 (mm) TOLERANCE
L ≤ 50	±1.5
50 < L ≤ 100	±2.5
100 < L ≤ 500	±3

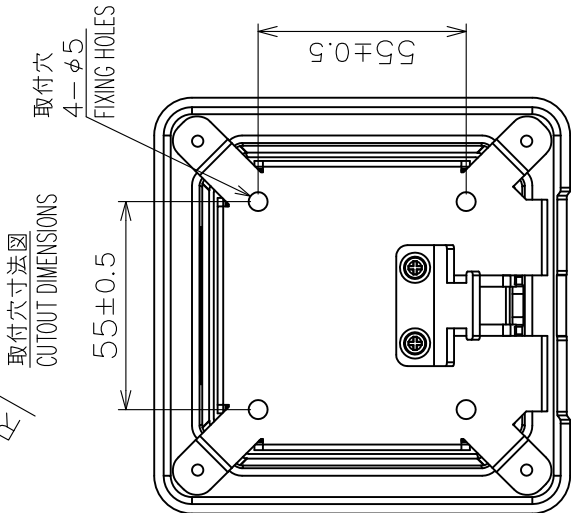
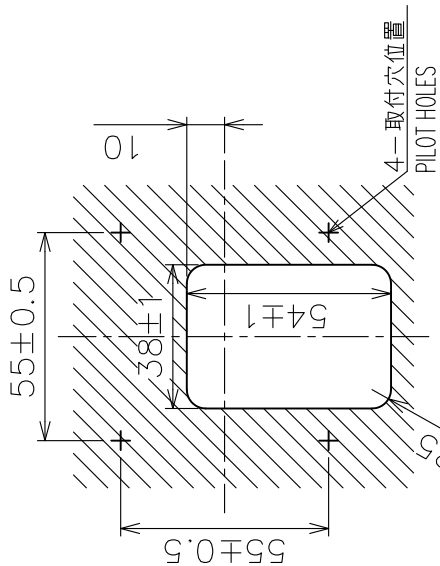
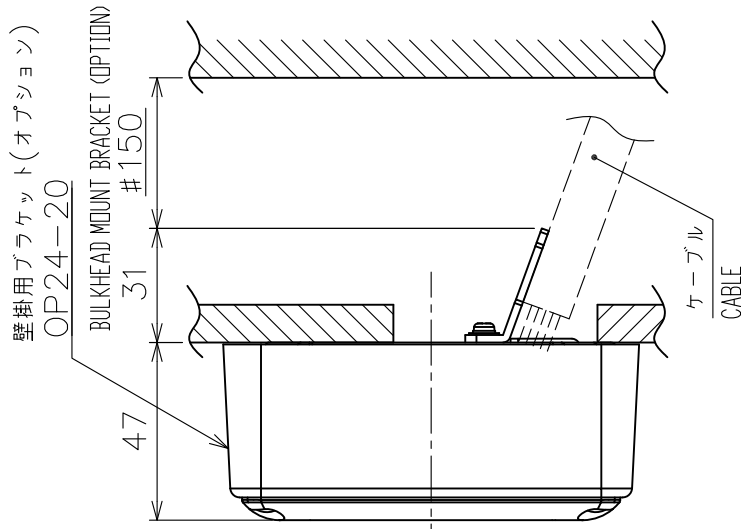
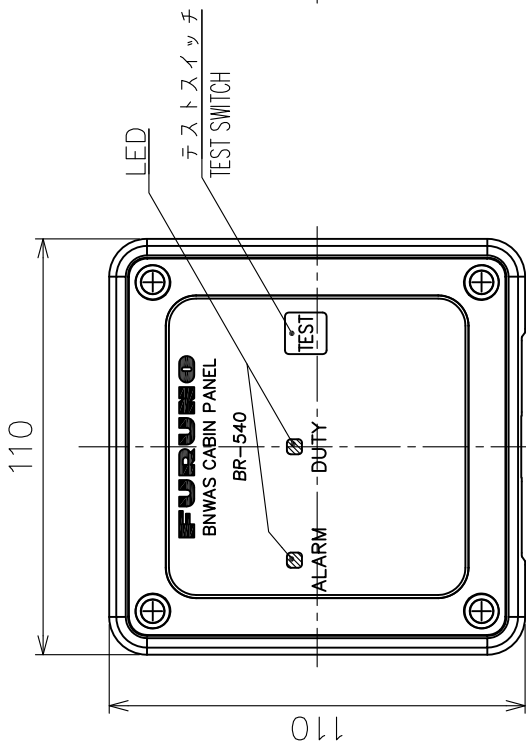
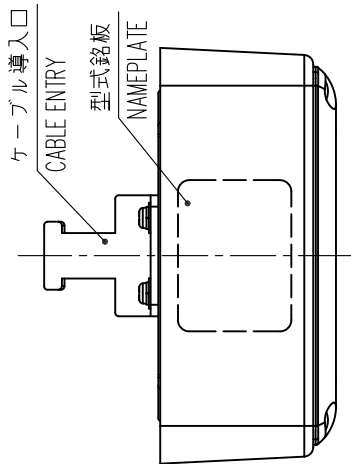

- 注記 1) 指定外の寸法公差は表 1 による。  
 2) #印寸法は最小サービスクリアランスとする。  
 3) 取付けはトラスタップピンネジ呼び径 4×2.0 を使用のこと。  
 4) 本体の取付けにはオプションの壁掛用ブラケット(OP24-20)が別途必要です。

- NOTE 1. TABLE 1 INDICATES TOLERANCE OF DIMENSIONS WHICH IS NOT SPECIFIED.  
 2. # MINIMUM SERVICE CLEARANCE.  
 3. USE TAPPING SCREWS  $\phi 4 \times 2.0$  FOR FIXING THE UNIT.  
 4. AN OPTIONAL BULKHEAD MOUNT ASSY. (OP24-20) REQUIRED FOR FIXING THE UNIT.

DRAWN	24/Aug/2021 U.PODDAR	TITLE	BR-540
CHECKED	24/Aug/2021 T.YAMASAKI	名称	キャビンパネル (壁掛装備)
APPROVED	27/Aug/2021 H.MAKI	外寸図	
SCALE	1/2	質量はケーブルを含みます。 MASS DOES NOT INCLUDE CABLE.	
FIG.No.	C4461-G10-D	REF.No.	24-012-411G-6



表 1 TABLE 1

寸法区分 (mm) DIMENSION	公差 (mm) TOLERANCE
L ≤ 50	±1.5
50 < L ≤ 100	±2.5
100 < L ≤ 500	±3

- 注 記 1) 指定外の寸法公差は表 1 による。  
 2) # 印寸法は最小サービスマン間寸法とする。  
 3) 取付けは、トラスタップピンネジ呼び径 4 × 1.6 を使用のこと。
- NOTE 1. TABLE 1 INDICATES TOLERANCE OF DIMENSIONS WHICH IS NOT SPECIFIED.  
 2. # MINIMUM SERVICE CLEARANCE.  
 3. USE TAPPING SCREWS Ø4x1.6 FOR FIXING THE UNIT.

DRAWN	20/Apr/2012	T.YAMASAKI	TITLE	BR-540
CHECKED	20/Apr/2012	H.IMAKI	名称	キャビンパネル (埋込装備)
APPROVED	20/Jun/2012	Y.NISHIYAMA	外寸図	
SCALE	1/2	質量はケーブルを含まず #印はケーブルを含まず MASS DOES NOT INCLUDE CABLE.	NAME	CABIN PANEL (FLUSH MOUNT)
DWG.No.	C4461-G18-A	REF.No.	24-012-420G-0	OUTLINE DRAWING

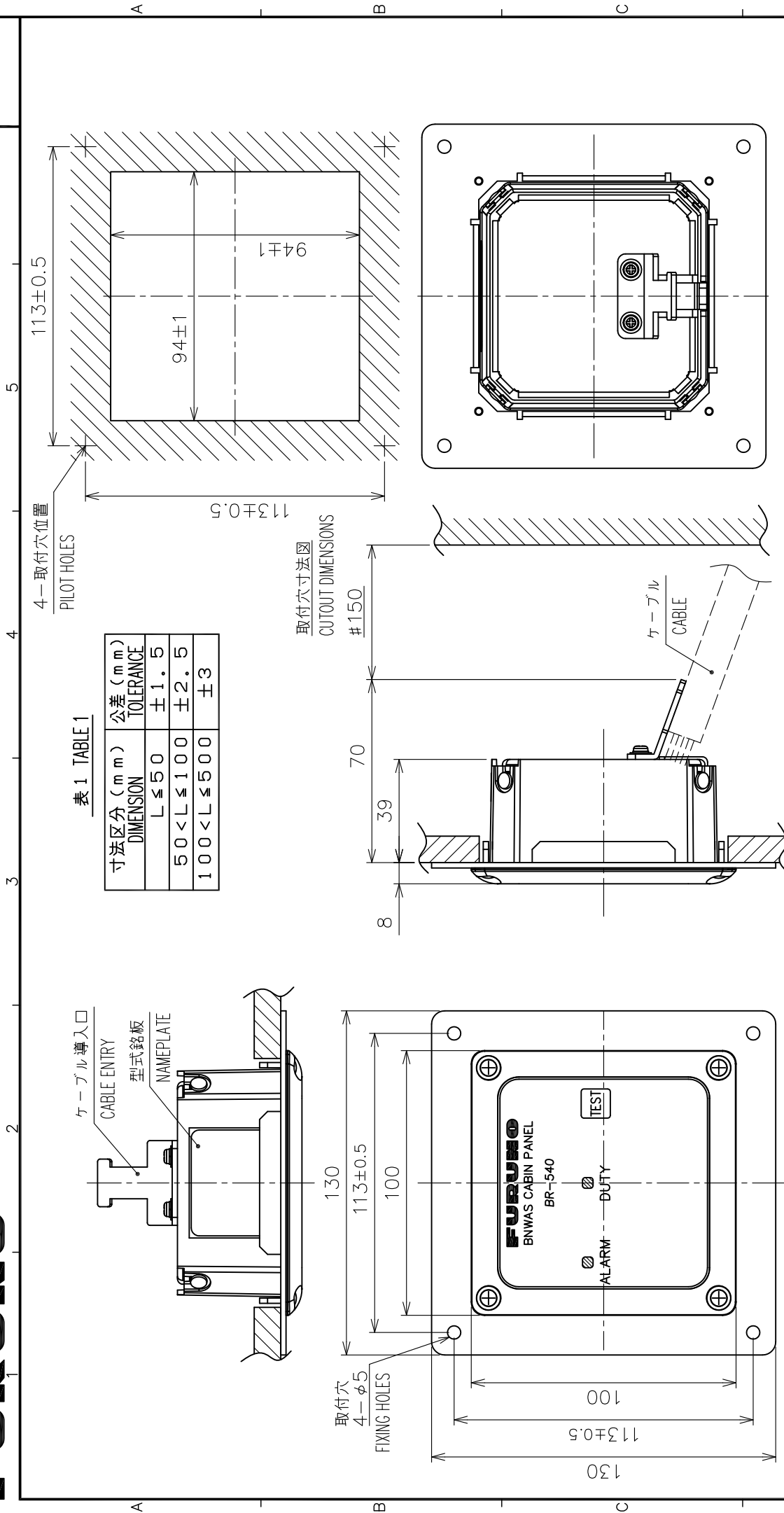

表 1 TABLE 1

寸法区分 (mm) DIMENSION	公差 (mm) TOLERANCE
L ≤ 50	±1.5
50 < L ≤ 100	±2.5
100 < L ≤ 500	±3

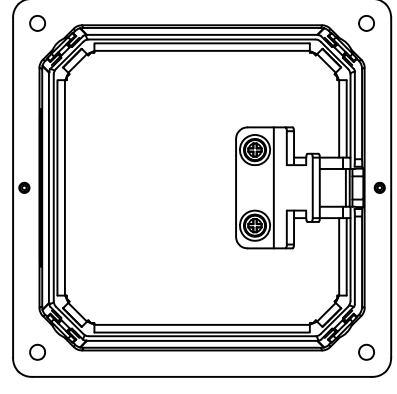
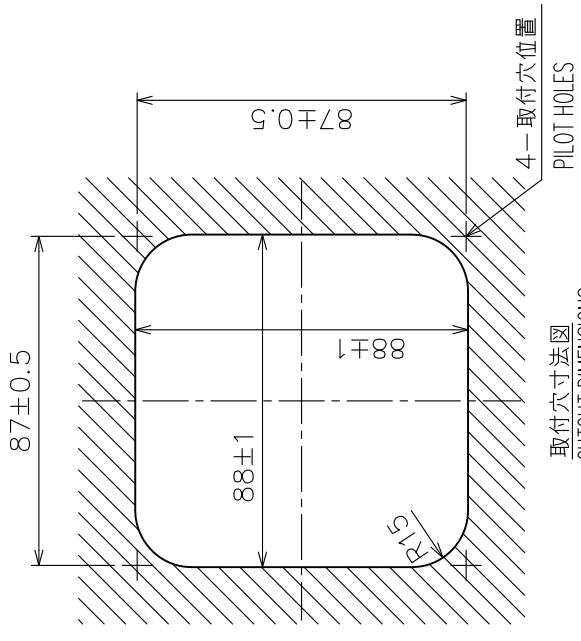
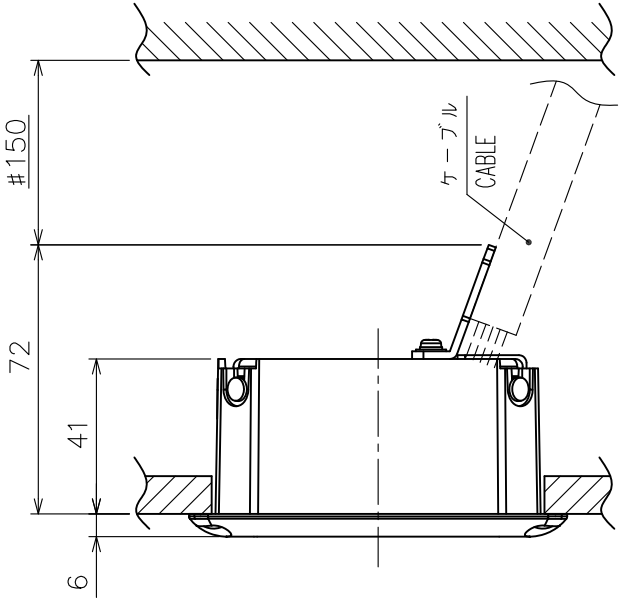
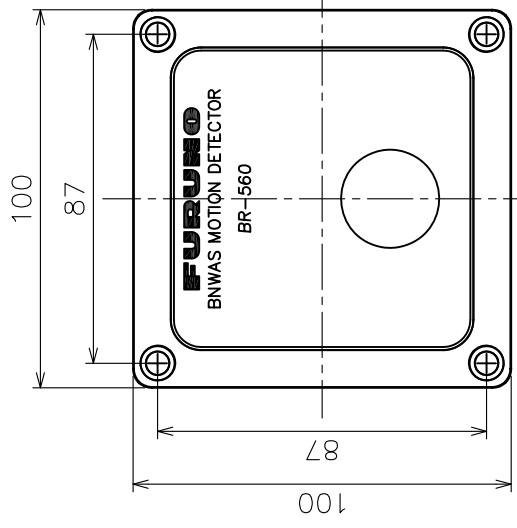
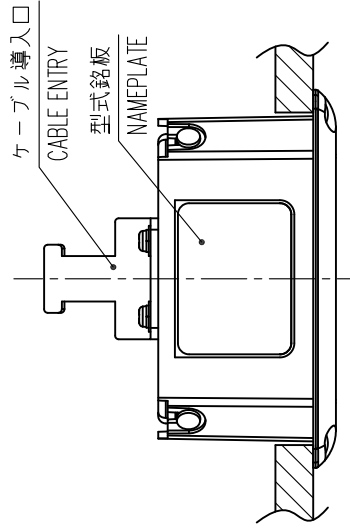

注 記

- 1) 指定外の寸法公差は表 1 による。
- 2) # 印寸法は最小サービスマン寸法とする。
- 3) 取り付けは、バイネジ呼び径 3 × 1.6 を使用のこと。

NOTE

1. TABLE 1 INDICATES TOLERANCE OF DIMENSIONS WHICH IS NOT SPECIFIED.
2. # MINIMUM SERVICE CLEARANCE.
3. USE BIND TAPPING SCREWS φ3x1.6 FOR FIXING THE UNIT.

DRAWN	4/Oct/2011	T.YAMASAKI	TITLE	BR-560
CHECKED	4/Oct/2011	H.MAKI	名称	モーション検出器 (埋込装備)
APPROVED	6/Oct/2011	Y.NISHIYAMA	外寸図	
SCALE	1/2	質量はケーブルを含みます。 ±0% 質量はケーブルを含まず。 kg MASS DOES NOT INCLUDE CABLE.	NAME	MOTION DETECTOR (FLUSH MOUNT)
DWG.No.	C4461-G11-C	REF.No.	24-012-500G-5	OUTLINE DRAWING

型式銘板  
NAMEPLATE

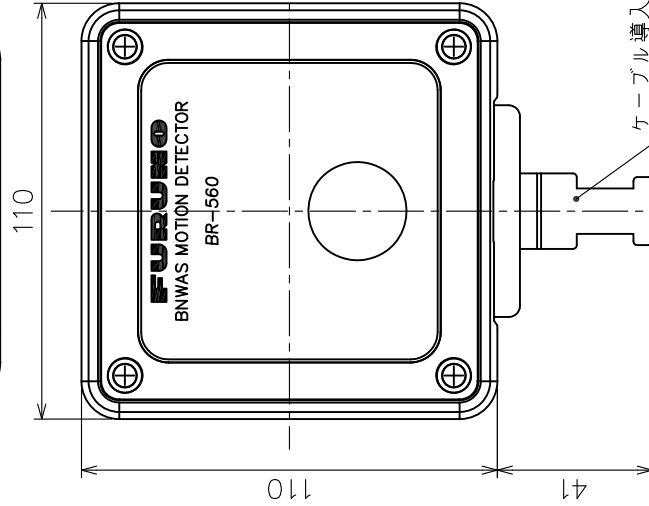
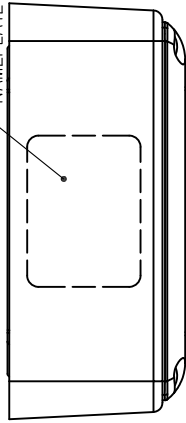

ケーブル導入口  
CABLE ENTRY



表 1 TABLE 1

寸法区分 (mm) DIMENSION	公差 (mm) TOLERANCE
L ≤ 50	±1.5
50 < L ≤ 100	±2.5
100 < L ≤ 500	±3

壁掛用ブラケット(オプション)  
OP24-20

BULKHEAD MOUNT BRACKET (OPTION)

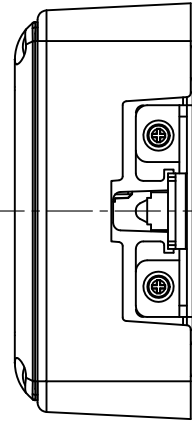
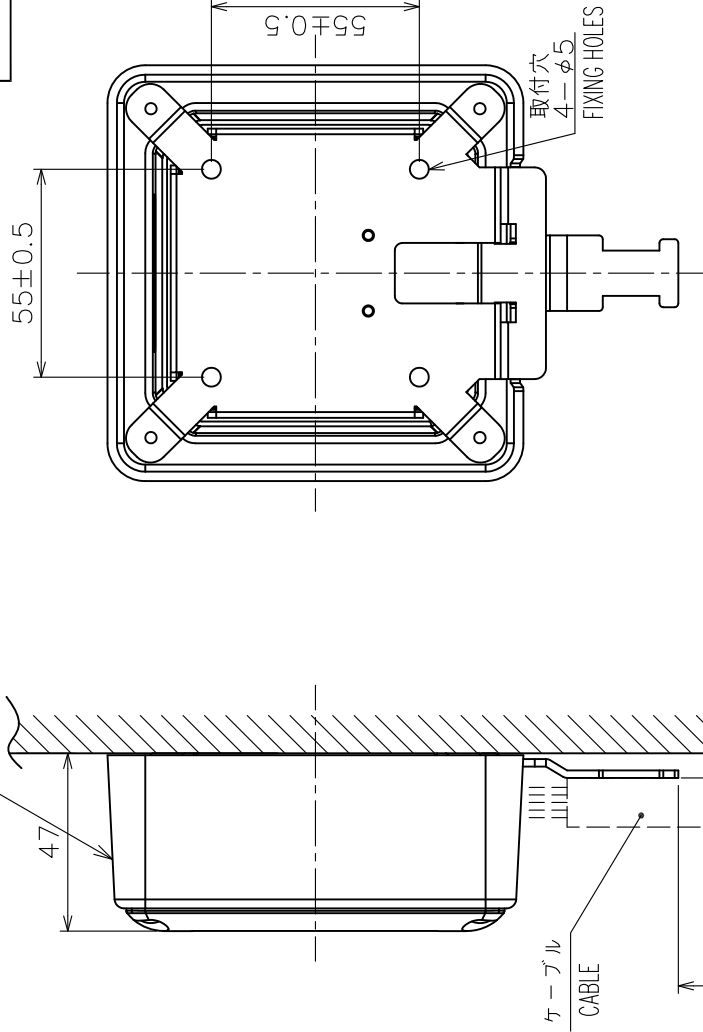

ケーブル  
CABLE

#150

NOTE

- TABLE 1 INDICATES TOLERANCE OF DIMENSIONS WHICH IS NOT SPECIFIED.
- # MINIMUM SERVICE CLEARANCE.
- USE TAPPING SCREWS  $\phi 4 \times 20$  FOR FIXING THE UNIT.
- AN OPTIONAL BULKHEAD MOUNT ASSY. (OP24-20) REQUIRED FOR FIXING THE UNIT.

注記

- 指定外の寸法公差は表 1 による。
- #印寸法は最小サービスクリアランスとする。
- 取り付けはトラスタツピンネジ呼び径  $4 \times 20$  を使用のこと。
- 本体の取り付けにはオプションの壁掛用ブラケット(OP24-20)が別途必要です。

DRAWN	24/Aug/2021	U.PODDAR	TITLE	BR-560
CHECKED	24/Aug/2021	I.YAMASAKI	各種	モーショ ン検出器 (壁掛装備)
APPROVED	27/Aug/2021	H.MAKI	外寸図	
SCALE	1/2	質量 0.31 kg #104 質量はケーブルを含みます。 MASS DOES NOT INCLUDE CABLE.	NAME	MOTION DETECTOR (BULKHEAD MOUNT)
DWG.No.	C4461-G12-D	REF.No.	24-012-510G-6	OUTLINE DRAWING



表 1 TABLE 1

寸法区分 (mm) DIMENSION	公差 (mm) TOLERANCE
L ≤ 50	±1.5
50 < L ≤ 100	±2.5
100 < L ≤ 500	±3

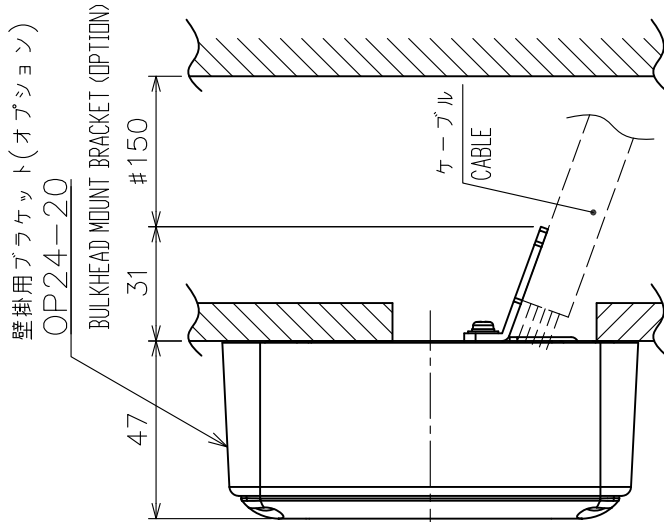
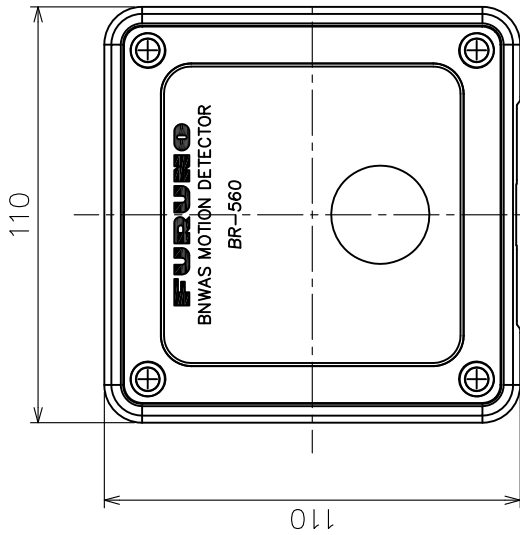
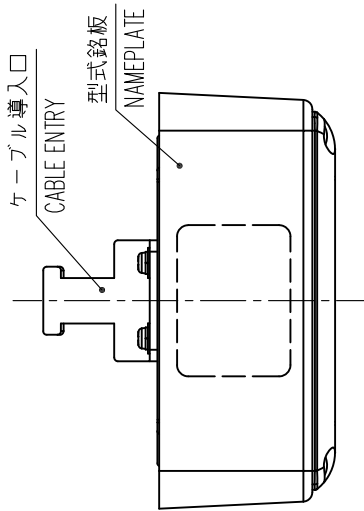
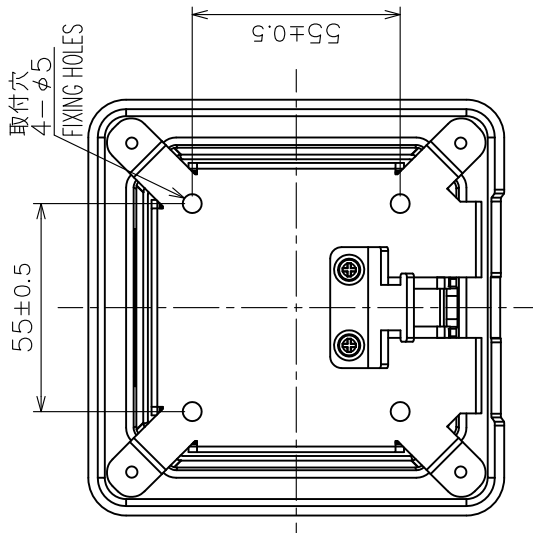
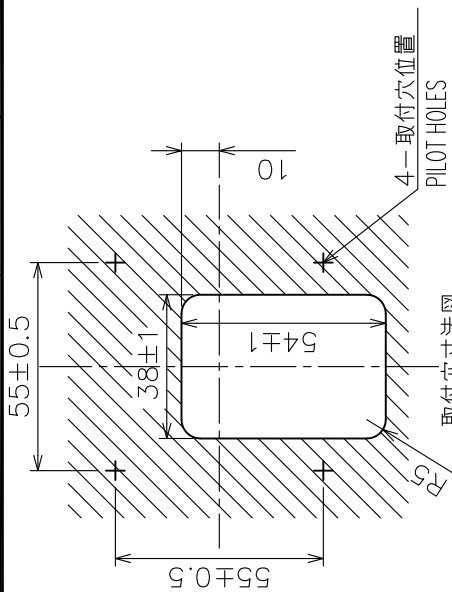

注 記

- 1) 指定外の寸法公差は表 1 による。
- 2) # 印寸法は最小サービスペース寸法とする。
- 3) 取り付けはトラスタップピンネジ呼び径 4×20 を使用のこと。
- 4) 本体の取付けにはオプションの壁掛用ブラケット(OP24-20)が別途必要です。

NOTE

1. TABLE 1 INDICATES TOLERANCE OF DIMENSIONS WHICH IS NOT SPECIFIED.
2. # MINIMUM SERVICE CLEARANCE.
3. USE TAPPING SCREWS φ4x20 FOR FIXING THE UNIT.
4. AN OPTIONAL BULKHEAD MOUNT ASSY. (OP24-20) REQUIRED FOR FIXING THE UNIT.

DRAWN	24/Aug/2021 U.PODDAR	TITLE	BR-560
CHECKED	24/Aug/2021 I.YAMASAKI	各種	モーショ ン検出器 (壁掛装備)
APPROVED	27/Aug/2021 H.MAKI	外寸図	
SCALE	1/2	質量はケーブルを含む。 #104 MASS DOES NOT INCLUDE CABLE.	MOTION DETECTOR (BULKHEAD MOUNT)
DWG.No.	C4461-G13-D	REF.No.	24-012-511G-6 OUTLINE DRAWING



表 1 TABLE 1

寸法区分 (mm) DIMENSION	公差 (mm) TOLERANCE
$L \leq 50$	$\pm 1.5$
$50 < L \leq 100$	$\pm 2.5$
$100 < L \leq 500$	$\pm 3$

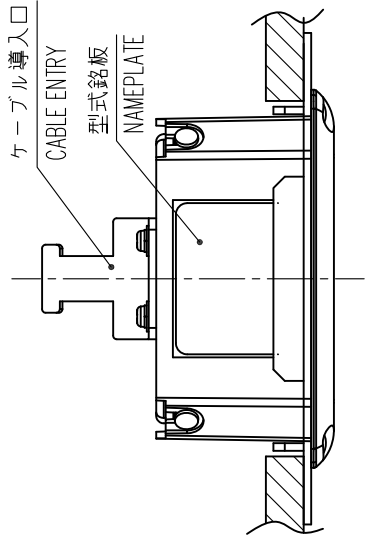
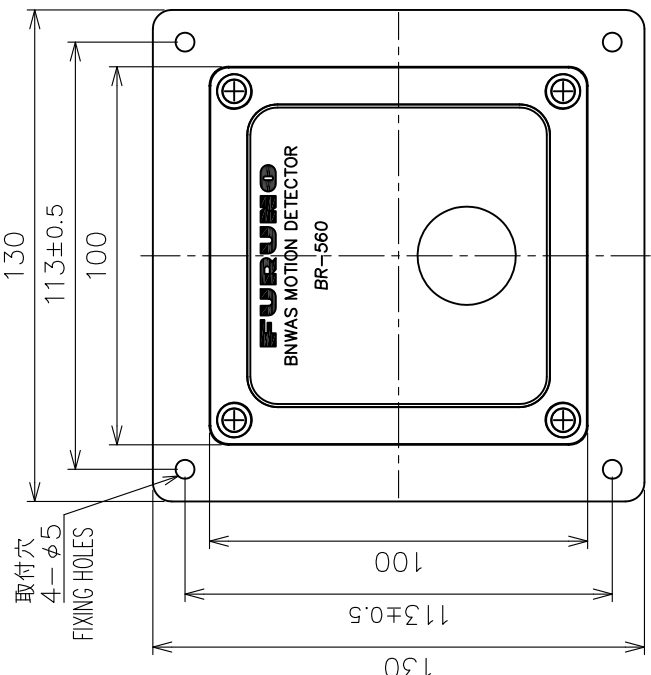
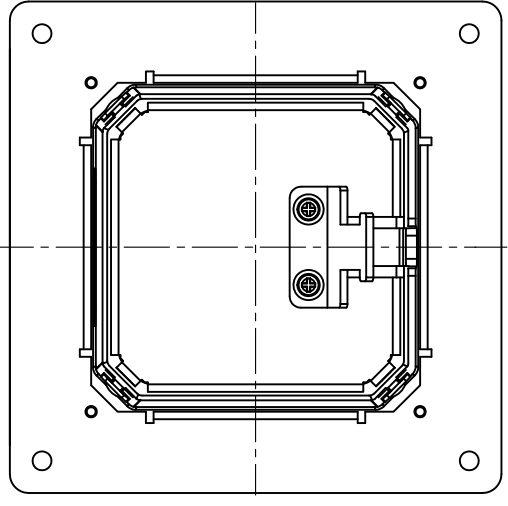
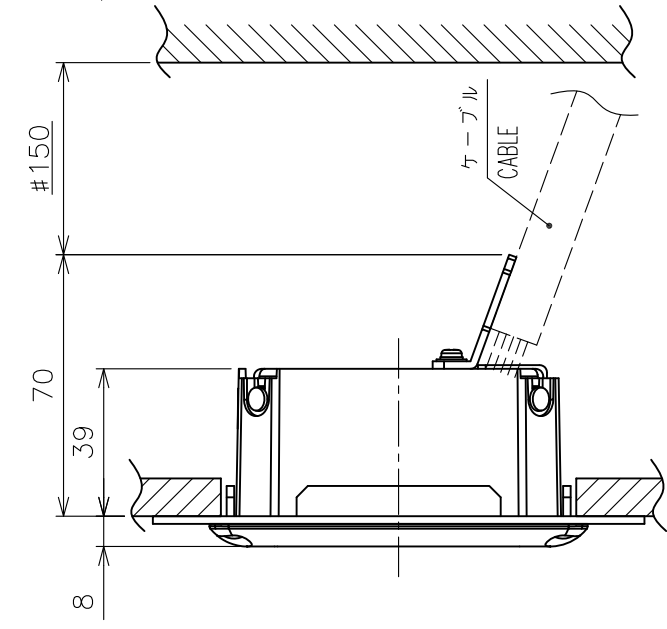
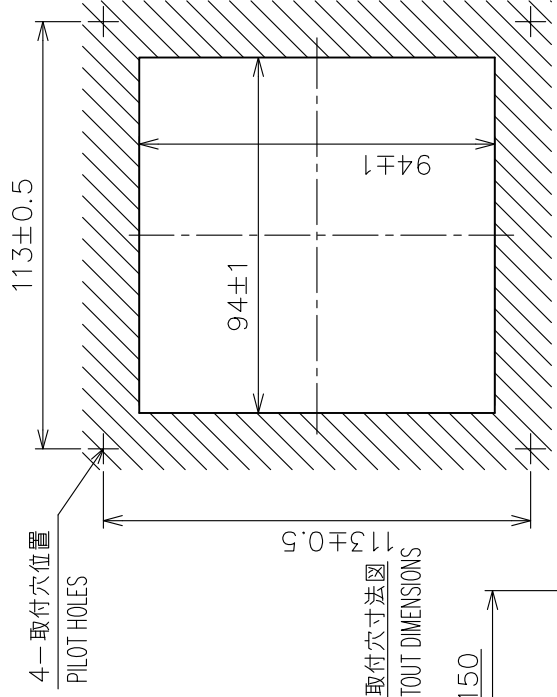

- 注 記
- 1) 指定外の寸法公差は表 1 による。
  - 2) # 印寸法は最小サービス空間寸法とする。
  - 3) 取付けは、トラスタップピンネジ呼び径 4 × 1.6 を使用のこと。
- NOTE
1. TABLE 1 INDICATES TOLERANCE OF DIMENSIONS WHICH IS NOT SPECIFIED.
  2. # MINIMUM SERVICE CLEARANCE.
  3. USE TAPPING SCREWS  $\phi 4 \times 1.6$  FOR FIXING THE UNIT.

DRAWN	20/Jun/2012	T.YAMASAKI	TITLE	BR-560
CHECKED	20/Jun/2012	H.MAKI	名称	モーション検出器 (埋込装備)
APPROVED	20/Jun/2012	Y.NISHIYAMA	外寸図	
SCALE	1/2	質量はケーブルを含みません。 MASS DOES NOT INCLUDE CABLE.	NAME	MOTION DETECTOR (FLUSH MOUNT)
DWG.No.	C4461-G19-A	REF.No.	24-012-512G-0	OUTLINE DRAWING

表 1 TABLE 1

寸法区分 (mm) DIMENSION	公差 (mm) TOLERANCE
$L \leq 50$	$\pm 1.5$
$50 < L \leq 100$	$\pm 2.5$
$100 < L \leq 500$	$\pm 3$

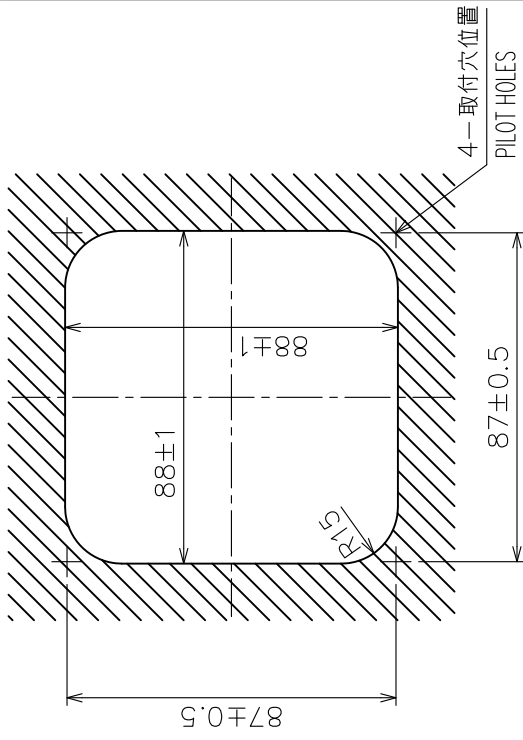
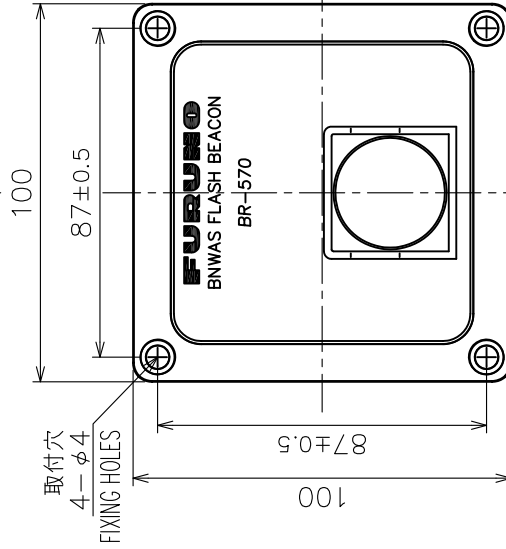
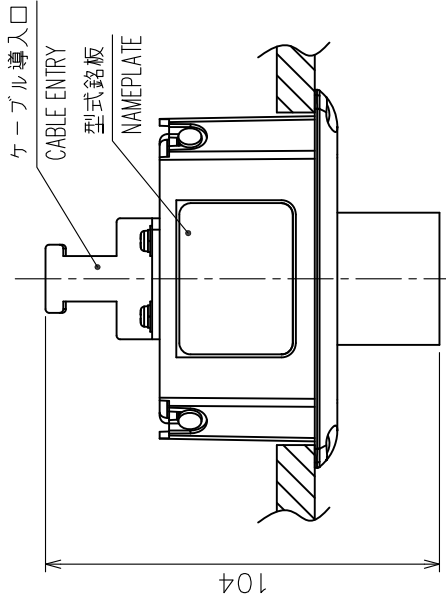

取付穴寸法図  
CUTOUT DIMENSIONS

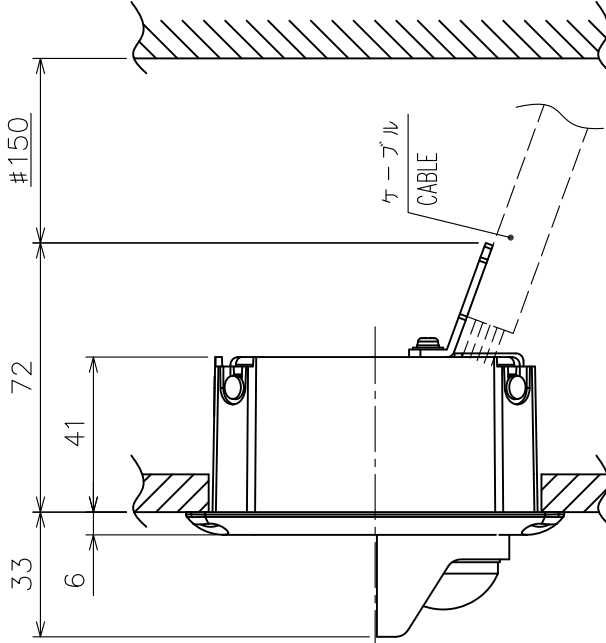
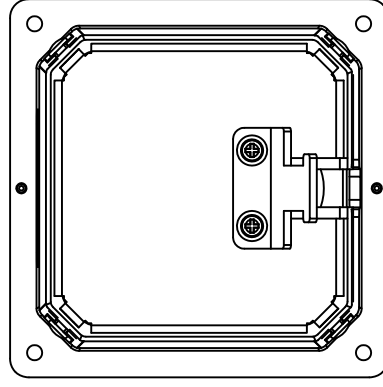

注 記

- 1) 指定外の寸法公差は表 1 による。
- 2) # 印寸法は最小サービス空間寸法とする。
- 3) 取り付けは、バインドット呼び径 3×16 を使用のこと。

NOTE

1. TABLE 1 INDICATES TOLERANCE OF DIMENSIONS WHICH IS NOT SPECIFIED.
2. # MINIMUM SERVICE CLEARANCE.
3. USE BIND TAPPING SCREWS φ3x16 FOR FIXING THE UNIT.

DRAWN	16/Feb/2011	T.YAMASAKI	TITLE	BR-570
CHECKED	16/Feb/2011	H.MAKI	名称	フラッシュビーコン (埋込装置)
APPROVED	16/Feb/2011	Y.NISHIYAMA	外寸図	
SCALE	1/2	質量はケーブルを含みます。 # 質量はケーブルを含みません。 MASS DOES NOT INCLUDE CABLE.	NAME	FLASH BEACON (FLUSH MOUNT)
DWG.No.	C4461-G14-C	REF.No.	24-012-520G-6	OUTLINE DRAWING

表 1 TABLE 1

寸法区分 (mm) DIMENSION	公差 (mm) TOLERANCE
L ≤ 50	±1.5
50 < L ≤ 100	±2.5
100 < L ≤ 500	±3

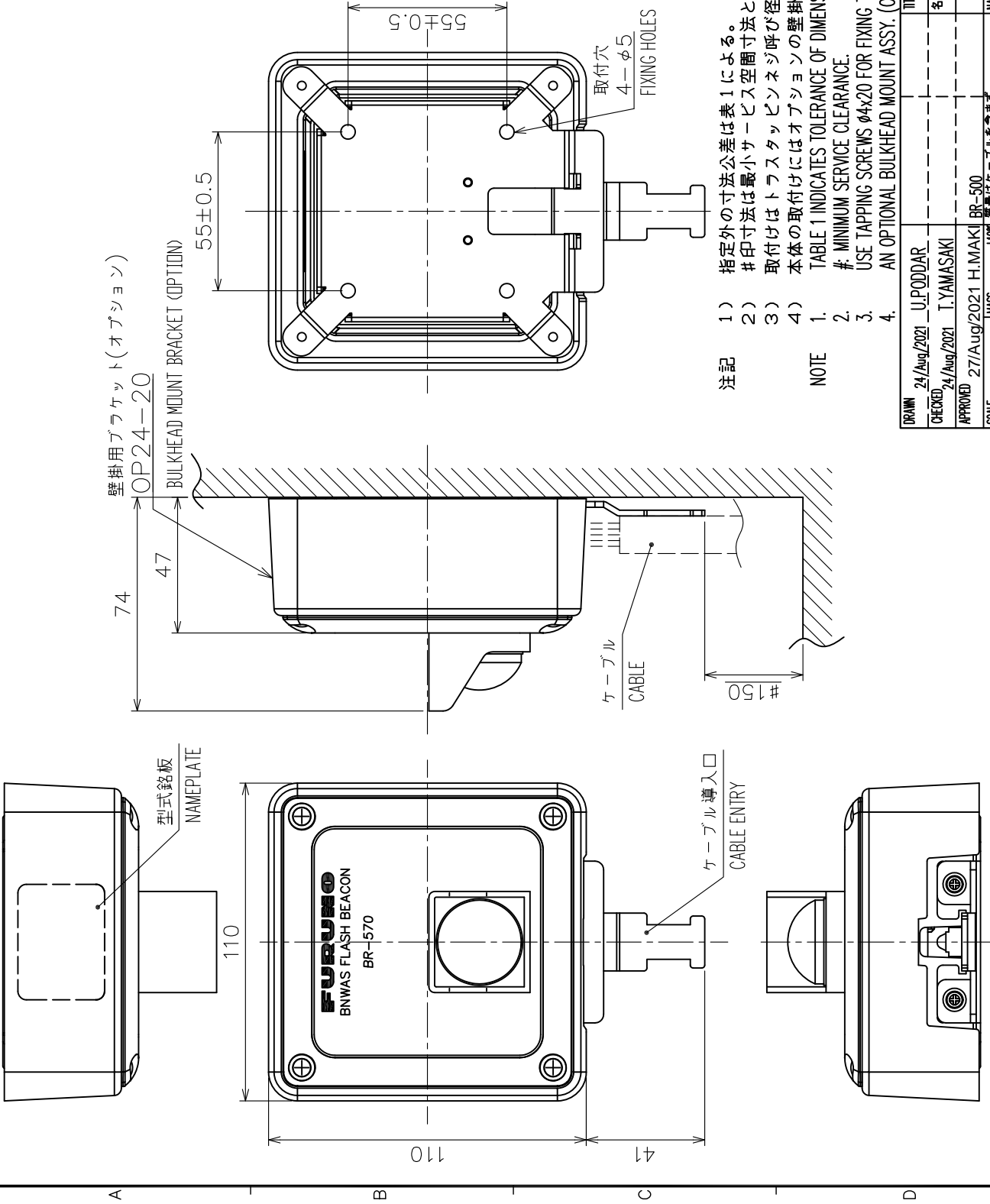

- 注記 1) 指定外の寸法公差は表 1 による。  
 2) #印寸法は最小サージス空間寸法とする。  
 3) 取付けはトラススタッピュピンネジ呼び径 4×2.0 を使用のこと。  
 4) 本体の取付けにはオプションの壁掛用ブラケット(OP24-20)が別途必要です。
- NOTE 1. TABLE 1 INDICATES TOLERANCE OF DIMENSIONS WHICH IS NOT SPECIFIED.  
 2. # MINIMUM SERVICE CLEARANCE.  
 3. USE TAPPING SCREWS φ4x2.0 FOR FIXING THE UNIT.  
 4. AN OPTIONAL BULKHEAD MOUNT ASSY. (OP24-20) REQUIRED FOR FIXING THE UNIT.

DRAWN	24/Aug/2021	U.PODDAR	TITLE	BR-570
CHECKED	24/Aug/2021	I.YAMASAKI	名称	フラッシュビーコン (壁掛装備)
APPROVED	27/Aug/2021	H.MAKI	外寸図	
SCALE	1/2	質量はケーブルを含む。 #104 MASS DOES NOT INCLUDE CABLE.	NAME	FLASH BEACON (BULKHEAD MOUNT)
DWG.No.	C4461-G15-D	REF.No.	24-012-530G-7	OUTLINE DRAWING



表 1 TABLE 1

寸法区分 (mm) DIMENSION	公差 (mm) TOLERANCE
L ≤ 50	±1.5
50 < L ≤ 100	±2.5
100 < L ≤ 500	±3

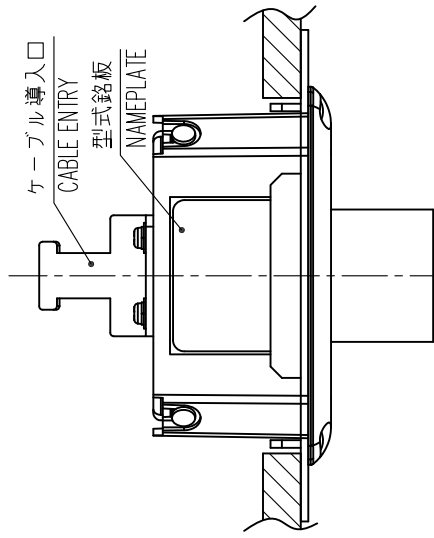
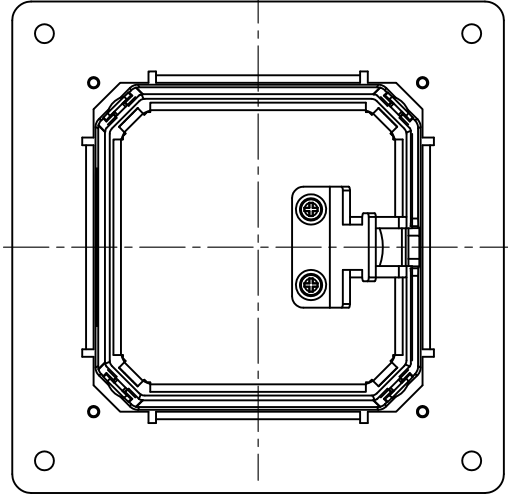
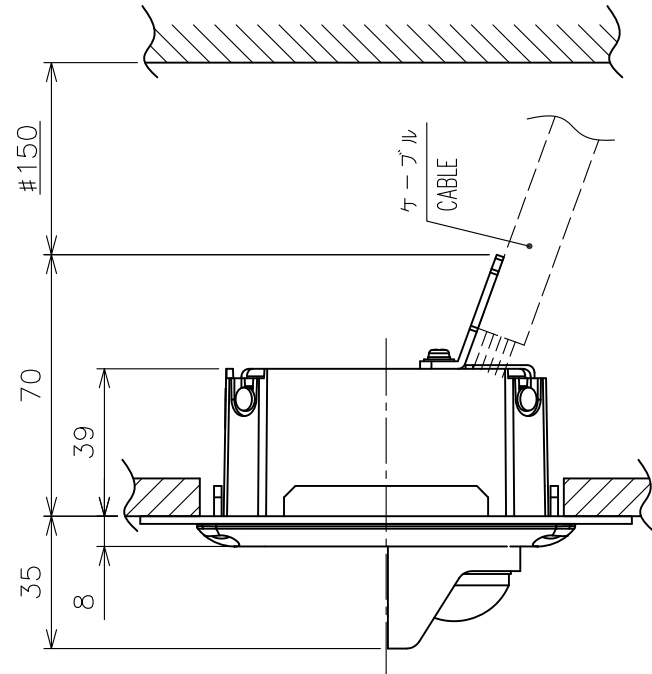
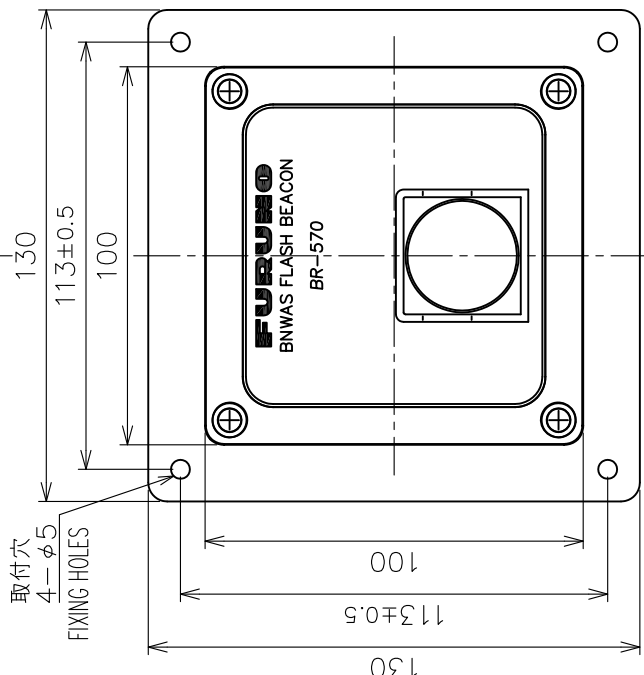
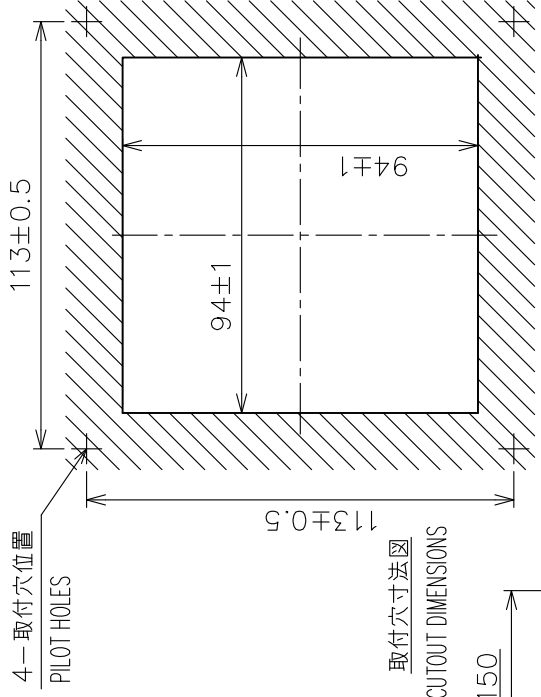

- 注 記
- 1) 指定外の寸法公差は表 1 による。
  - 2) # 印寸法は最小サービス空間寸法とする。
  - 3) 取付けは、トラスタップピンネジ呼び径 4 × 1.6 を使用のこと。
- NOTE
1. TABLE 1 INDICATES TOLERANCE OF DIMENSIONS WHICH IS NOT SPECIFIED.
  2. # MINIMUM SERVICE CLEARANCE.
  3. USE TAPPING SCREWS φ4x1.6 FOR FIXING THE UNIT.

DRAWN	20/Jun/2012	T.YAMASAKI	TITLE	BR-570
CHECKED	20/Jun/2012	H.MAKI	名称	フラッシュビーコン (埋込装備)
APPROVED	20/Jun/2012	Y.NISHIYAMA	外寸図	
SCALE	1/2	質量はケーブルを含みません。 質量はケーブルを含みません。 MASS DOES NOT INCLUDE CABLE.	NAME	FLASH BEACON (FLUSH MOUNT)
DWG.No.	C4461-G20-A	REF.No.	24-012-532G-0	OUTLINE DRAWING

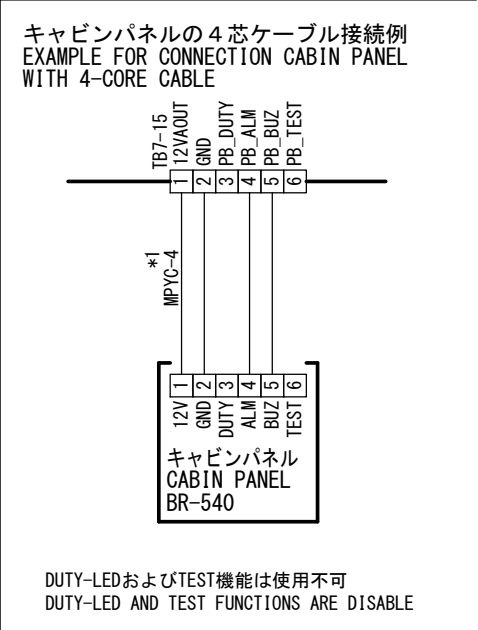
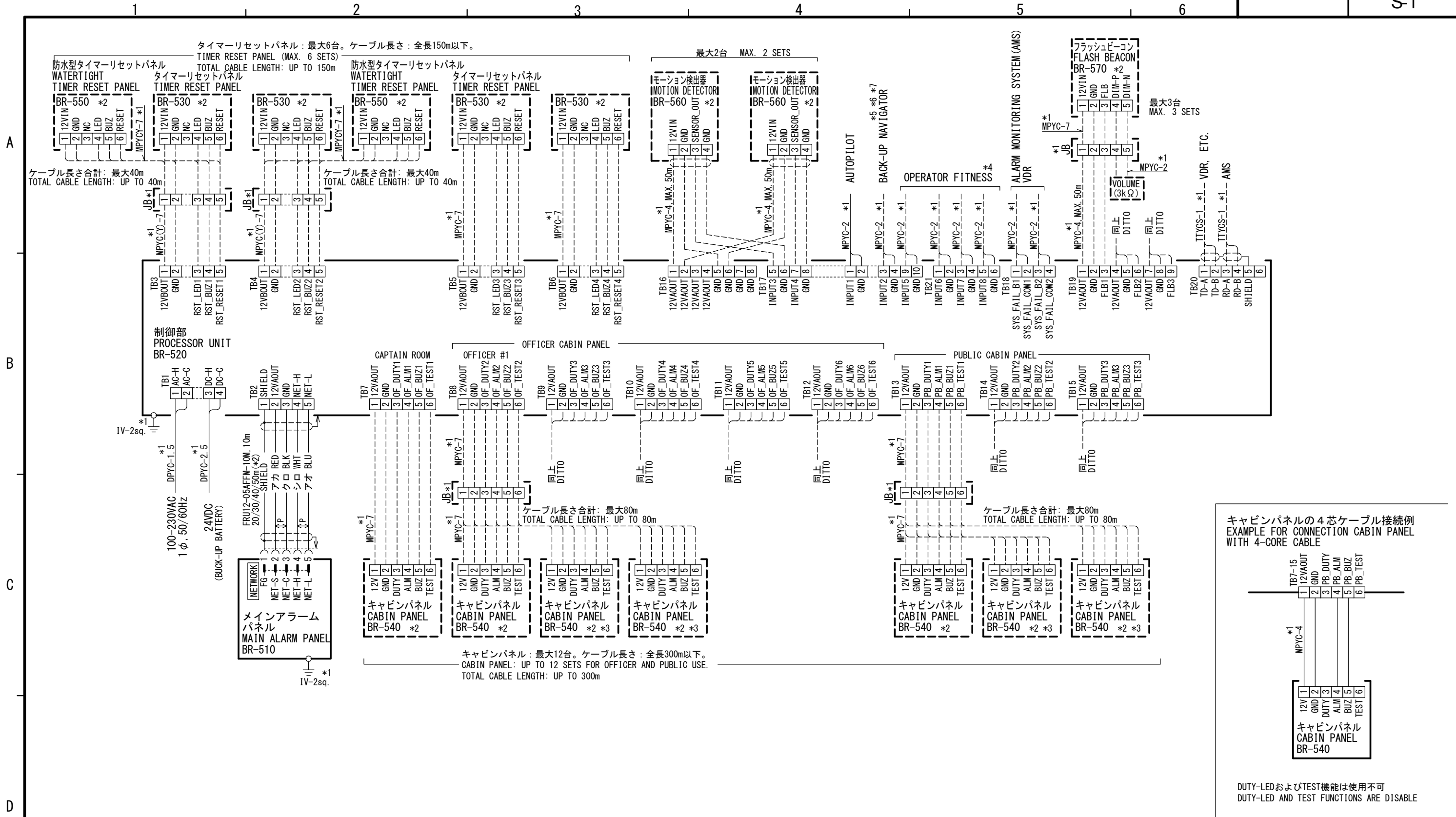

- 注記
- \* 1) 造船所手配。
  - \* 2) オプション。
  - \* 3) キャビンパネルは最大3台まで接続可能。
  - \* 4) モーション検出器に変更可能。
  - \* 5) モーション検出器・オペレータフィットネスに変更可能。
  - \* 6) BACK-UP NABIGATOR信号を入力する場合、ノーマルクローズ接点を接続してください。
  - \* 7) 外部緊急呼出しを強制リセットするには、この端子間をショートしてください。

- NOTE
- \*1: SHIPYARD SUPPLY.
  - \*2: OPTION.
  - \*3: MAX. 3 CABIN PANELS CAN BE INSTALLED.
  - \*4: CONNECTION CAN BE CHANGED TO MOTION DETECTOR.
  - \*5: CONNECTION CAN BE CHANGED TO MOTION DETECTOR OR OPERATOR FITNESS.
  - \*6: CONNECT NORMAL CLOSE CONTACT FOR BACK-UP NAVIGATOR SIGNAL INPUT.
  - \*7: SHORT THE TERMINALS TO RESET THE EXTERNAL EMERGENCY CALLING.

DRAWN	1/Jul/2016 T. YAMASAKI	TITLE	BR-500
CHECKED	1/Jul/2016 H. MAKI	名称	船橋航海当直警報装置
APPROVED	1/Jul/2016 H. MAKI		相互結線図
SCALE	MASS kg	NAME	BRIDGE NAVIGATIONAL WATCH ALARM SYSTEM
DWG No.	C4461-C01-S	REF. No.	24-012-6001-3
			INTERCONNECTION DIAGRAM



# INDEX

---

## **Numerics**

2nd stage interval ..... 4-18

## **A**

Abbreviations ..... AP-1

alarm ..... 4-14

Alarm sequence ..... 1-5

## **B**

Backlighting ..... 1-3

Backup officer ..... 4-19

BNWAS display ..... 1-2

Brilliance ..... 1-3

Buzzer type ..... 4-19

## **C**

Cabin panel

operation ..... 2-2

troubleshooting ..... 3-3

Captain backup ..... 4-19

Control description ..... 1-1

## **D**

Default settings ..... 4-23

## **E**

Emergency call ..... 1-12

EMG key ..... 1-1, 1-12

ENT/CALL key ..... 1-1, 1-13

External emergency call ..... 1-13

## **F**

Flash Beacon ..... 2-4

Fuse replacement ..... 3-2

## **H**

Help area ..... 1-9

## **I**

I/O Sentences ..... 4-24

input ..... 4-25

output ..... 4-26

## **K**

Key beep ..... 4-19

## **L**

Language ..... 4-20

## **M**

Maintenance ..... 3-1

Menu tree ..... AP-1

MENU/ESC key ..... 1-1

MODE key ..... 1-1, 1-5

Mode selection ..... 1-5

Motion detector ..... 2-3

## **N**

Navigation officer call ..... 1-13

## **O**

Operational event ..... 1-11

## **P**

Power on/off ..... 1-1

## **R**

RESET key ..... 1-1

## **S**

SEL key ..... 1-1, 1-4

Software history ..... vi

System failure ..... 1-9

## **T**

Timer reset panel ..... 2-1

Troubleshooting ..... 3-2

## **W**

Watch time interval ..... 4-18

Watertight timer reset panel ..... 2-1

## Declaration of Conformity



# 0560

We **FURUNO ELECTRIC CO., LTD.**

-----  
(Manufacturer)

9-52 Ashihara-Cho, Nishinomiya City, 662-8580, Hyogo, Japan

-----  
(Address)

declare under our sole responsibility that the product

**BRIDGE NAVIGATIONAL WATCH ALARM SYSTEM BR-500**

(Serial No. 6423/6428/6431-xxxx)

-----  
(Model name, type number)

to which this declaration relates conforms to the following standard(s) or normative document(s)

IMO Resolution A.694(17)	IEC 60945 Ed.4.0: 2002 incl. Corr. 1: 2008
IMO Resolution MSC.128(75)	IEC 61162-1 Ed. 5.0: 2016
IMO Resolution MSC.191(79)	IEC 62288 Ed. 2.0: 2014
IMO Resolution MSC.302(87)	IEC 62616 Ed. 1.0: 2010
IMO MSC.1/Circ.1474	IEC 62923-1/2 Ed.1.0: 2018

-----  
(title and/or number and date of issue of the standard(s) or other normative document(s))

For assessment, see

- EC Type Examination (Module B) certificate No. MEDB000011T Rev.2 issue by DNV AS (0575), Norway.
- Product Quality System (Module D) certificate No. P 112 (Issue 62) issued by Telefication, The Netherlands.

This declaration is issued according to the Directive 2014/90/EU of the European Parliament and of the Council on marine equipment, and the Implementing Regulation (EU) 2021/1158.

On behalf of Furuno Electric Co., Ltd.

Nishinomiya City, Japan  
23 December 2021

-----  
(Place and date of issue)

Akihiko Kanechika  
Department General Manager  
Quality Assurance Department

  
-----  
(name and signature or equivalent marking of authorized person)