

# **FURUNO**

## **OPERATOR'S MANUAL**

*COLOR SCANNING SONAR*

Model **FSV-85 MARK-2**

---

**ECF**

(Elemental Chlorine Free)

The paper used in this manual  
is elemental chlorine free.

**FURUNO ELECTRIC CO., LTD.**

9-52 Ashihara-cho,  
Nishinomiya, 662-8580, JAPAN

• FURUNO Authorized Distributor/Dealer

All rights reserved. Printed in Japan

Pub. No. OME-13670-B

(REFU ) FSV-85-MARK-2-70/80

A : JUL. 2021

B : JUN. 10, 2022



0 0 0 1 9 8 9 0 2 1 1

# IMPORTANT NOTICES

---

## General

- This manual has been authored with simplified grammar, to meet the needs of international users.
- The operator of this equipment must read and follow the instructions in this manual. Wrong operation or maintenance can void the warranty or cause injury.
- Do not copy any part of this manual without written permission from FURUNO.
- If this manual is lost or worn, contact your dealer about replacement.
- The contents of this manual and the equipment specifications can change without notice.
- The example screens (or illustrations) shown in this manual can be different from the screens you see on your display. The screens you see depend on your system configuration and equipment settings.
- Save this manual for future reference.
- Any modification of the equipment (including software) by persons not authorized by FURUNO will void the warranty.
- The following concern acts as our importer in Europe, as defined in DECISION No 768/2008/EC.
  - Name: FURUNO EUROPE B.V.
  - Address: Siriusstraat 86, 5015 BT, Tilburg, The Netherlands
- The following concern acts as our importer in UK, as defined in SI 2016/1025 as amended SI 2019/470.
  - Name: FURUNO (UK) LTD.
  - Address: West Building Penner Road Havant Hampshire PO9 1QY, U.K.
- All brand, product names, trademarks, registered trademarks, and service marks belong to their respective holders.

## How to discard this product

Discard this product according to local regulations for the disposal of industrial waste. For disposal in the USA, see the homepage of the Electronics Industries Alliance (<http://www.eiae.org/>) for the correct method of disposal.

## How to discard a used battery

Some FURUNO products have a battery(ies). To see if your product has a battery, see the chapter on Maintenance. If a battery is used, tape the + and - terminals of the battery before disposal to prevent fire, heat generation caused by short circuit.

### In the European Union

The crossed-out trash can symbol indicates that all types of batteries must not be discarded in standard trash, or at a trash site. Take the used batteries to a battery collection site according to your national legislation and the Batteries Directive 2006/66/EU.

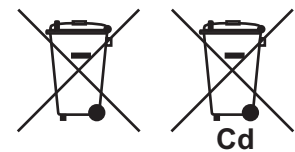

### In the USA

The Mobius loop symbol (three chasing arrows) indicates that Ni-Cd and lead-acid rechargeable batteries must be recycled. Take the used batteries to a battery collection site according to local laws.

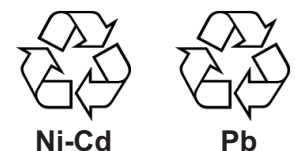



### In the other countries

There are no international standards for the battery recycle symbol. The number of symbols can increase when the other countries make their own recycle symbols in the future.



# SAFETY INSTRUCTIONS

The operator of this equipment must read the safety instructions before attempting to operate the equipment.

 <b>DANGER</b>	Indicates a hazardous situation which, if not avoided, will result in death or serious injury.
 <b>WARNING</b>	Indicates a potentially hazardous situation which, if not avoided, could result in death or serious injury.
 <b>CAUTION</b>	Indicates a potentially hazardous situation which, if not avoided, may result in minor or moderate injury.

 Warning, Caution	 Prohibitive Action	 Mandatory Action
--	--	--

 **DANGER**



**Keep away from raise/lower shaft in hull unit when it is moving.**

Gears in hull unit will cause serious injury.

 **WARNING**

 **Do not disassemble or modify the equipment.**

Fire, electrical shock or serious injury can result.

 **Do not install the equipment where it may be subject to rain or water splash.**

Fire or electrical shock can result if water leaks in the equipment.

 **Use the proper fuse.**

Use of a wrong fuse can result in damage to the equipment or cause fire.

 **Do not operate the equipment with wet hands.**

Electrical shock may result.

 **Do not place liquid-filled containers on the top of the equipment.**

Fire or electrical shock can result if a liquid spills into the equipment.

 **Turn off the power immediately if you feel the equipment is behaving abnormally.**

Turn off the power at the switchboard if the equipment becomes abnormally warm or is emitting odd noises. Contact a FURUNO dealer or agent for advice.

 **WARNING**

 **Do not open the equipment.**

Only qualified personnel should work inside the equipment.





 **Immediately turn off the power at the switchboard if water leaks into the equipment or something is dropped into the equipment.**



Continued use of the equipment can cause fire or electrical shock. Contact a FURUNO agent for service.

 **Immediately turn off the power at the switchboard if the equipment is emitting smoke or fire.**

Continued use of the equipment can cause fire or electrical shock. Contact a FURUNO agent for service.





 <b>CAUTION</b>	
 <b>Maximum speed while the transducer is projected and being raised or lowered is as below, to prevent damage to the transducer.</b>	
Projected	Raising/ Lowering
Max. 18 kn	Max. 15 kn
 <b>Replace anticorrosion zinc plate yearly.</b> Corrosion between the main shaft and transducer may result if not replaced, allowing water leakage and/or loss of transducer.	
 <b>The LCD is made of glass. Do not apply force or shock to the LCD.</b> Broken LCD glass can cause injury.	

 <b>CAUTION</b>	
 <b>Observe the following precautions when using industrial use lubricant.</b>	
<b>Precautions</b>	
<ul style="list-style-type: none"> <li>Keep lubricant away from eyes. Wear protective goggles when working with the lubricant. The lubricant can cause inflammation of the eyes.</li> <li>Do not touch the lubricant. Wear protective gloves when working with the lubricant. The lubricant can cause inflammation of the skin.</li> <li>Do not ingest the lubricant. Diarrhea and vomiting may result.</li> <li>Keep the lubricant out of reach of children.</li> </ul>	
<b>Emergency procedures</b>	
<ul style="list-style-type: none"> <li>If the lubricant enters eyes, flush with clean water about 15 minutes. Consult a physician.</li> <li>If the lubricant contacts skin, flush area with clean water.</li> <li>If the lubricant is ingested, see a physician immediately.</li> </ul>	
<b>Disposal of lubricant and its container</b>	
Dispose of the lubricant and its container in accordance with local regulations. If you are unclear about the disposal procedure, contact a FURUNO agent or dealer for advice.	



**WARNING LABELS**

Warning labels are attached to the units of the system. Do not remove the labels.

If a label is missing or damaged, contact a FURUNO agent or dealer about replacement.

	 <b>WARNING</b>
	Moving main shaft can pinch and cut. Keep hands clear while operating. Lockout power before servicing.
	 <b>警告</b>
	上下動シャフト部分は手をはさむ恐れあり。 稼働中は手を近づけないこと。 サービスを行う前は電源を切ること。

Name: Finger Warning Label  
Type: 06-021-4015  
Code No.: 100-281-590-10

	 <b>DANGER</b>
	Electrical shock hazard. Do not remove cover. No user-serviceable parts inside. Turn off power before servicing. And wait until charge lamp (green) goes off and then remove cover.
	 <b>危険</b>
	感電の恐れあり。 サービスマン以外の方は、カバーを開けないで下さい。内部には高圧部品が数多くあり、万一さわると危険です。 サービスマンがカバーを開ける場合は、電源をOFFした後、CHARGEランプ(緑)が消滅していることを確認してから開けてください。

Name: Warning Label  
Type: 10-079-6144  
Code No.: 100-310-880-10

 <b>WARNING</b> 
To avoid electrical shock, do not remove cover. No user-serviceable parts inside.
 <b>警告</b> 
感電の恐れあり。 サービスマン以外の方はカバーを開けないで下さい。内部には高圧部分が数多くあり、万一さわると危険です。

Name: Warning Label (1)  
Type: 86-003-1011-3  
Code No.: 100-236-233-10

	 <b>DANGER</b>
	Electrical shock hazard. Do not remove cover. No user-serviceable parts inside. Turn off power before servicing.
	 <b>危険</b>
	感電の恐れあり。 サービスマン以外の方はカバーを開けないで下さい。内部には高圧部分が数多くあり、万一さわると危険です。 サービスマンがサービスを行う前には、必ず電源をOFFして下さい。

Name: Danger Label  
Type: 10-089-7544-0  
Code No.: 100-394-370-10

# EMERGENCY STOP BUTTON ON HULL UNIT

---

The **EMERGENCY STOP** button on the hull unit stops the raising or lowering of the transducer in case of an emergency. The transducer stops moving when the button is operated, a warning message appears and the transducer cannot be raised or lowered. The transducer is also stopped when the ratchet wrench in the hull unit, which is used to manually raise the transducer, is removed from its holder.

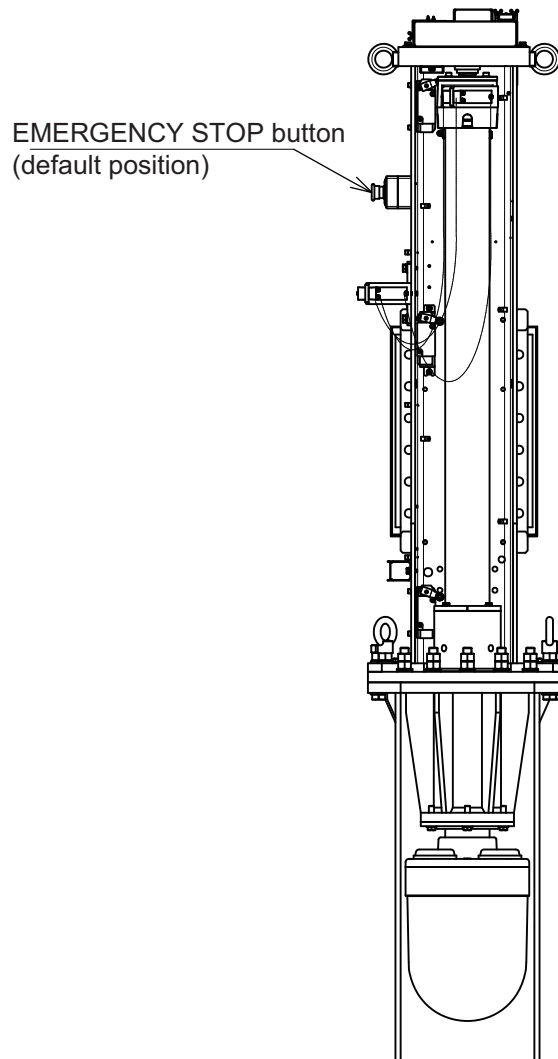

To release the emergency stop condition, first confirm that no one is near the hull unit. Then do the following:

- To release the **EMERGENCY STOP** button, turn the button in the direction of the arrow on the button.
- Return the ratchet wrench to its holder.

# TABLE OF CONTENTS

---

<b>FOREWORD</b> .....	<b>x</b>
<b>SYSTEM CONFIGURATION</b> .....	<b>xi</b>
<b>1. OPERATIONAL OVERVIEW</b> .....	<b>1-1</b>
1.1 Controls Overview .....	1-1
1.1.1 Control Unit .....	1-1
1.1.2 Sub control unit (option) .....	1-4
1.1.3 Remote controller (Option) .....	1-4
1.2 Turning the Power On/Off.....	1-5
1.3 Raising/Lowering the Transducer.....	1-5
1.3.1 Lowering the transducer .....	1-6
1.3.2 Raising the transducer .....	1-7
1.3.3 How to check transducer protrusion .....	1-7
1.4 Screen Brilliance and Panel Dimmer.....	1-8
1.5 Display Modes .....	1-10
1.5.1 How to select a display mode.....	1-11
1.5.2 Display mode pictures .....	1-12
1.6 Software Function Keys.....	1-14
1.7 How to Adjust the Gain.....	1-15
1.8 How to Use the Menu.....	1-16
<b>2. HORIZONTAL MODE</b> .....	<b>2-1</b>
2.1 Basic Operating Procedure .....	2-1
2.2 Horizontal Display Overview.....	2-2
2.2.1 Horizontal mode, full-screen display .....	2-2
2.2.2 Horizontal2 mode .....	2-3
2.3 Display Range .....	2-4
2.4 Tilt Angle.....	2-5
2.4.1 How to set the tilt angle .....	2-5
2.4.2 Automatic tilt.....	2-5
2.4.3 Relation between bottom echo and tilt angle .....	2-7
2.4.4 Tilt angle for surface fish .....	2-8
2.4.5 Suitable tilt angle .....	2-8
2.5 How to Measure Range and Bearing to a Target.....	2-9
2.6 How to Eliminate Weak Echoes .....	2-9
2.7 How to Adjust Strong and Weak Echoes.....	2-12
2.7.1 AGC.....	2-12
2.7.2 Near AGC.....	2-12
2.7.3 2nd AGC.....	2-13
2.7.4 How to shorten pulse length.....	2-14
2.8 How to Suppress Bottom and Sea Surface Reflections in Shallow Waters .....	2-15
2.9 How to Reject Sonar Interference and Noise .....	2-16
2.9.1 How to identify the noise source .....	2-16
2.9.2 Change TX interval.....	2-16
2.9.3 Interference rejector .....	2-17
2.9.4 Shift TX frequency.....	2-17
2.9.5 Noise limiter.....	2-18
2.9.6 Reverberation.....	2-18
2.9.7 Echo average .....	2-18
2.9.8 Reference bearing in frequency shift.....	2-19
2.9.9 How to suppress sidelobes .....	2-19

## TABLE OF CONTENTS

2.10	How to Adjust Beam Width .....	2-20
2.11	How to Track a School of Fish .....	2-21
2.11.1	How to select the target lock mode .....	2-21
2.11.2	Fish mode .....	2-22
2.11.3	Target mark mode.....	2-22
2.11.4	Target lock menu description .....	2-23
2.12	Presentation Mode .....	2-24
2.12.1	Presentation mode description.....	2-24
2.12.2	How to select a presentation mode.....	2-25
2.13	How to Detect Schools of Fish Aurally .....	2-25
2.13.1	How to set the bearing .....	2-25
2.13.2	How to select the audio sector .....	2-26
2.13.3	Automatic training .....	2-26
2.13.4	Reverberation for audio signal .....	2-27
2.14	Fish Alarm .....	2-27
2.15	How to Relocate a School of Fish .....	2-28
2.16	How to Compare Concentration of School of Fish .....	2-29
2.16.1	How to compare with the fish estimate mark .....	2-29
2.16.2	How to compare with the circle cursor .....	2-30
2.17	How to Measure the Speed of a School of Fish.....	2-31
2.17.1	How to measure the speed of a school of fish .....	2-31
2.17.2	How to delete fish marks.....	2-32
2.18	Event Mark, Own Ship Position Mark.....	2-33
2.18.1	How to enter an event mark.....	2-33
2.18.2	How to enter an own ship position mark .....	2-34
2.18.3	How to erase an event mark, own ship position mark.....	2-34
2.19	Select Mark Window .....	2-34
2.20	Net Course Mark .....	2-35
2.21	Net Behavior .....	2-36
2.22	Menu Items Descriptions.....	2-37
2.23	How to Interpret the Horizontal Display.....	2-40
2.23.1	Bottom and school of fish echoes .....	2-40
2.23.2	Unnecessary echoes.....	2-42
<b>3.</b>	<b>VERTICAL MODE.....</b>	<b>3-1</b>
3.1	Basic Operating Procedure .....	3-1
3.2	How the Vertical Mode Works.....	3-2
3.2.1	Overview .....	3-2
3.2.2	How to set the vertical display.....	3-2
3.3	Vertical Indications and Marks .....	3-3
3.3.1	Typical vertical display .....	3-3
3.3.2	Vertical bearing mark, tilt mark.....	3-4
3.3.3	Cursor position reference mark.....	3-5
3.4	Auto Train.....	3-5
3.5	Display Range.....	3-6
3.6	How to Measure the Range, Bearing to a Target.....	3-6
3.7	How to Eliminate Weak Echoes .....	3-7
3.8	How to Adjust Strong and Weak Echoes .....	3-9
3.8.1	AGC .....	3-9
3.8.2	Near AGC.....	3-9
3.8.3	2nd AGC .....	3-10
3.8.4	How to shorten pulse length.....	3-10
3.9	How to Reject Sonar Interference and Noise.....	3-11
3.9.1	How to identify the noise source .....	3-11
3.9.2	Interference rejector .....	3-12
3.9.3	Shift TX frequency.....	3-12

3.9.4	Noise limiter.....	3-13
3.9.5	Reverberation.....	3-14
3.9.6	Echo average.....	3-14
3.9.7	How to suppress sidelobes.....	3-14
3.10	How to Adjust Beam Width.....	3-15
3.11	Other Menu Items.....	3-16
3.12	Usage in Bonito and Tuna Fishing.....	3-17
3.12.1	Searching.....	3-17
3.12.2	Tracking.....	3-17
3.12.3	Approaching.....	3-18
3.12.4	Catching.....	3-18
<b>4.</b>	<b>SLANT MODE.....</b>	<b>4-1</b>
4.1	Basic Operating Procedure.....	4-1
4.2	Indications and Marks.....	4-2
4.2.1	Slant mode, full-screen display.....	4-2
4.2.2	Slant mode, combination display.....	4-3
4.3	Display Range.....	4-4
4.4	Tilt Angle.....	4-4
4.4.1	How to set the tilt angle.....	4-4
4.4.2	Automatic tilt.....	4-5
4.5	Auto Train.....	4-6
4.6	How to Measure Range and Bearing to a Target.....	4-6
4.7	How to Eliminate Weak Echoes.....	4-7
4.8	How to Adjust Strong and Weak Echoes.....	4-8
4.8.1	AGC.....	4-8
4.8.2	Near AGC.....	4-9
4.8.3	2nd AGC.....	4-9
4.8.4	How to shorten pulse length.....	4-10
4.9	How to Suppress Bottom and Sea Surface Reflections in Shallow Waters.....	4-11
4.10	How to Reject Sonar Interference and Noise.....	4-12
4.10.1	How to identify the noise source.....	4-12
4.10.2	Change TX interval.....	4-12
4.10.3	Interference rejector.....	4-13
4.10.4	Shift TX frequency.....	4-13
4.10.5	Noise limiter.....	4-14
4.10.6	Reverberation.....	4-14
4.10.7	Echo average.....	4-15
4.10.8	How to suppress sidelobes.....	4-15
4.11	How to Adjust Beam Width.....	4-15
4.12	How to Track a School of Fish.....	4-16
4.12.1	How to select the target lock mode.....	4-16
4.12.2	Fish mode.....	4-17
4.12.3	Target mark mode.....	4-18
4.12.4	Target lock menu description.....	4-18
4.13	How to Detect Schools of Fish Aurally.....	4-19
4.13.1	How to set the bearing.....	4-19
4.13.2	How to select the audio sector.....	4-19
4.13.3	Reverberation for audio signal.....	4-20
4.14	Fish Alarm.....	4-20
4.15	How to Relocate a School of Fish.....	4-21
4.15.1	Manual offcenter.....	4-21
4.15.2	Automatic offcenter.....	4-22
4.16	How to Compare Concentration of School of Fish.....	4-23
4.16.1	How to compare with the fish estimate mark.....	4-23
4.16.2	How to compare with the circle cursor.....	4-23

## TABLE OF CONTENTS

4.17	How to Measure the Speed of a School of Fish.....	4-25
4.17.1	How to measure the speed of a school of fish .....	4-25
4.17.2	How to delete fish marks.....	4-26
4.18	Event Mark.....	4-27
4.18.1	How to enter an event mark.....	4-27
4.18.2	How to erase an event mark.....	4-28
4.19	Net Course Mark.....	4-28
4.20	Net Data.....	4-29
4.21	Menu Items Descriptions.....	4-30
4.22	How to Interpret the Slant Display.....	4-32
4.22.1	Bottom echoes.....	4-32
4.22.2	School of fish.....	4-33
4.22.3	False echoes.....	4-34
<b>5.</b>	<b>NUMERIC/GRAPHIC DATA DISPLAY.....</b>	<b>5-1</b>
5.1	Numeric/Graphic Data Display.....	5-1
5.2	Numeric, Graphic Data Description.....	5-2
<b>6.</b>	<b>HOW TO CUSTOMIZE THE SONAR.....</b>	<b>6-1</b>
6.1	User Menu.....	6-1
6.1.1	How to program the user menu.....	6-1
6.1.2	How to delete items from the user menu .....	6-2
6.2	Function Keys (1/F1-0/F10).....	6-2
6.2.1	How to execute a program.....	6-3
6.2.2	How to program the function keys.....	6-3
6.2.3	How to erase programs.....	6-4
6.2.4	How to program the function keys of sub control unit.....	6-5
6.3	USER PROG Control.....	6-6
6.3.1	How to select a user program.....	6-6
6.3.2	How to program the USER PROG control.....	6-6
6.3.3	How to program display ranges.....	6-7
6.4	Remote Controller (option).....	6-8
<b>7.</b>	<b>OTHERS MENU.....</b>	<b>7-1</b>
7.1	Erase Marks Menu.....	7-1
7.2	Wheel Setting Menu.....	7-2
7.3	Display Setting Menu.....	7-3
7.4	Alarm & Audio Menu.....	7-5
7.5	Register Menu.....	7-6
7.6	Initial Setting Menu.....	7-7
7.6.1	Monitor Setting menu.....	7-8
7.6.2	Data Box menu.....	7-9
7.6.3	Mark Display menu.....	7-9
7.6.4	Mark Size menu.....	7-11
7.6.5	Data Display menu.....	7-12
7.6.6	Current Vec & Wind menu.....	7-13
7.6.7	Net SONDE Setting menu.....	7-14
7.6.8	Net Shooting Setting menu.....	7-15
7.6.9	Stabilization menu.....	7-15
7.6.10	Initialization menu.....	7-16
<b>8.</b>	<b>RECORD/RECALL OPERATION.....</b>	<b>8-1</b>
8.1	How to Specify Where to Save Still Images.....	8-1
8.2	How to Save Still Image.....	8-2
8.3	How to Display Saved Still Images.....	8-4
8.4	How to Save Settings.....	8-5

8.5	How to Load Files .....	8-6
8.5.1	How to load the setting information .....	8-6
8.5.2	How to replay setting information .....	8-7
8.6	How to Delete Files .....	8-8
<b>9.</b>	<b>MAINTENANCE .....</b>	<b>9-1</b>
9.1	Preventative Maintenance .....	9-1
9.2	Hull Unit Maintenance .....	9-2
9.2.1	How to grease parts .....	9-3
9.2.2	How to replace the gasket.....	9-4
9.2.3	How to replace the anti-corrosion zinc plates.....	9-5
9.3	Battery on the Motherboard.....	9-6
9.4	How to Replace Fuses .....	9-6
9.5	How to Clean and Replace the Filter.....	9-7
9.6	Trackball Maintenance .....	9-7
9.7	Troubleshooting.....	9-8
9.8	Warning Messages.....	9-10
9.9	Error Codes .....	9-12
9.10	Status Messages .....	9-12
9.11	Tests.....	9-12
9.11.1	Test menu .....	9-12
9.11.2	Board test.....	9-14
9.11.3	Panel test .....	9-15
9.11.4	Test pattern .....	9-16
9.12	How to Raise the Transducer from the Hull Unit.....	9-16
9.12.1	How to raise the transducer automatically .....	9-16
9.12.2	How to raise the transducer manually .....	9-18
9.13	How to Check the Brake in the Hull Unit .....	9-19
9.13.1	How to check the brake in the raise/lower control box .....	9-19
9.13.2	How to measure the gap in the motor brake .....	9-20
<b>APPX. 1</b>	<b>MENU TREE .....</b>	<b>AP-1</b>
<b>SPECIFICATIONS</b> .....		<b>SP-1</b>
<b>INDEX</b> .....		<b>IN-1</b>

# FOREWORD

---

## A Word the Owner of the FSV-85 MARK-2

Congratulations on your choice of the FURUNO FSV-85 MARK-2 Color Scanning Sonar. We are confident you will see why the FURUNO name has become synonymous with quality and reliability.

Since 1948, FURUNO Electric Company has enjoyed an enviable reputation for quality marine electronics equipment. This dedication to excellence is furthered by our extensive global network of agents and dealers.

This equipment is designed and constructed to meet the rigorous demands of the marine environment. However, no machine can perform its intended function unless operated and maintained properly. Please carefully read and follow the recommended procedures for operation and maintenance.

Thank you for considering and purchasing FURUNO equipment.

## Features

The FSV-85 MARK-2 is a full-circle, multibeam electronic color scanning sonar which detects and displays schools of fish on the monitor of your choice.

The main features of the FURUNO FSV-85 MARK-2 are

- Cylindrical + sphere transducer provides 90 degrees vertical detection.
- Schools of fish can be searched from horizontal (range direction), vertical (depth direction) with vertical and half-circle features.
- Function keys for direct access to desired menu item.
- Dual Display mode
- User programs for one-touch setup of equipment.
- Menu-driven operation.
- Fish histogram shows signal strength distribution of echo within estimate mark.
- Various marks and alphanumeric fishing and navigation information for intuitive operation.
- Storage and replay of picture and settings.
- Audio function for monitoring echoes along user-selected area through loudspeaker (option).
- Fish mark estimates fish speed.
- Fish estimate feature to compare the volume of two schools of fish.
- Net course mark shows probable drift of net against tidal current.
- Pitching and rolling compensation for stable picture always.

## CE/UKCA declaration

With regards to CE/UKCA declarations, please refer to our website ([www.furuno.com](http://www.furuno.com)) for further information about RoHS conformity declarations.

## Disclosure of Information about China RoHS

With regards to China RoHS information for our products, please refer to our website ([www.furuno.com](http://www.furuno.com)).



# SYSTEM CONFIGURATION

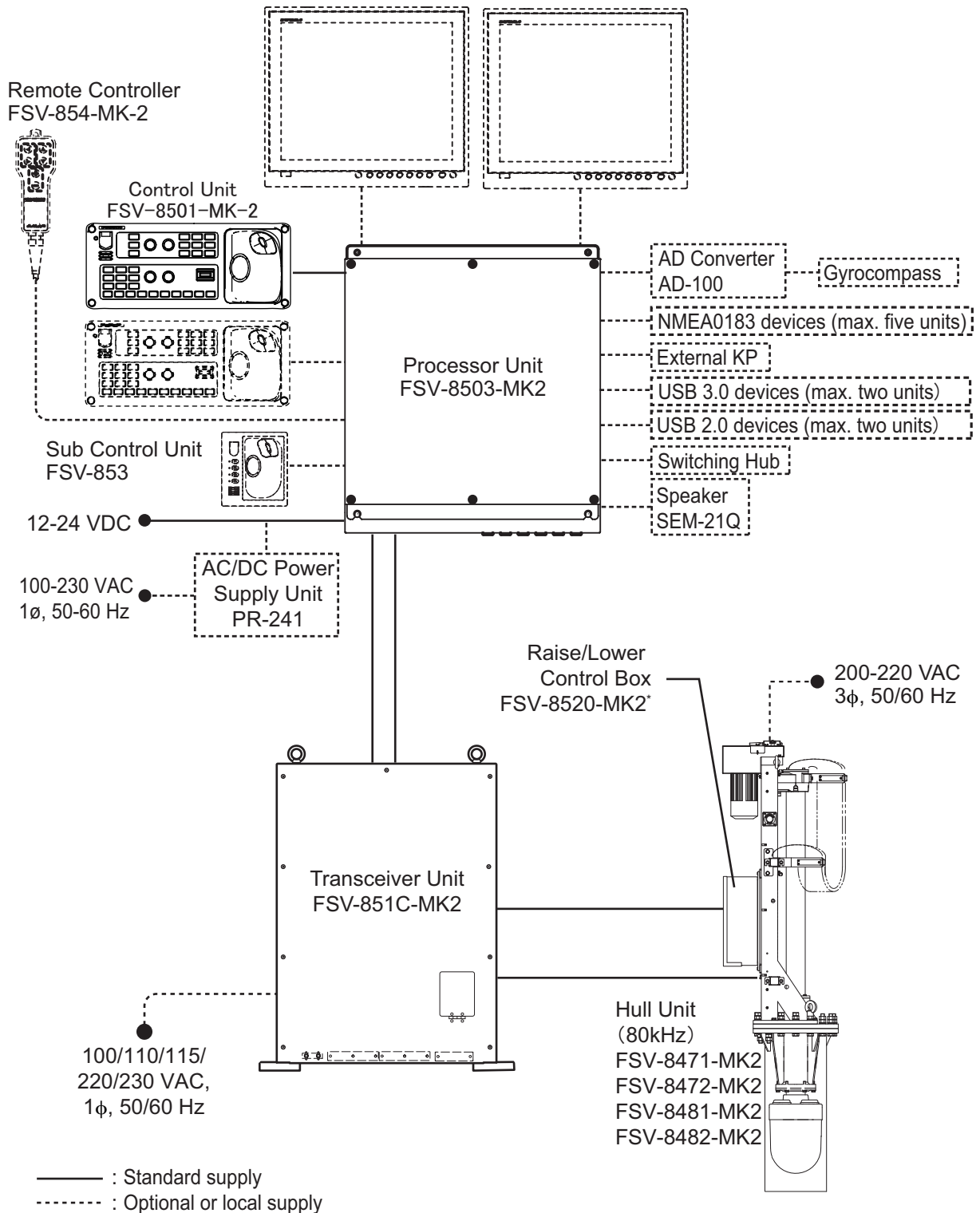

\*: Use the optional Control Box Extension Box (FSV-2560) to extend the distance between the raise/lower control box and the hull unit.





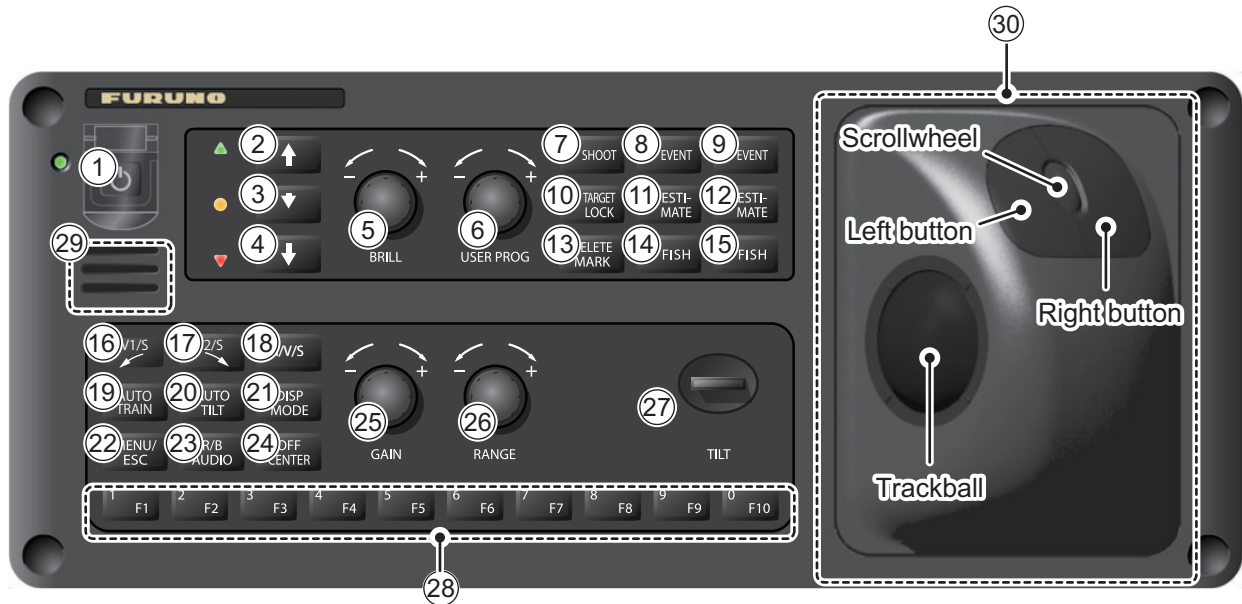

This page is intentionally left blank.

# 1. OPERATIONAL OVERVIEW



















## 1.1 Controls Overview



### 1.1.1 Control Unit



No.	Key/Control	Description
①		Press to turn the power on or off.
②		Raises the transducer.
③		<b>If the mid protrusion key is programmed to [Fixed Position]:</b> Lowers the transducer to half protrusion. <b>If the mid protrusion key is programmed to [Any Position]:</b> The transducer stops at desired position.
④		Lowers the transducer (full protrusion).
⑤	 BRILL	Adjusts the screen brilliance. <b>Note:</b> Monitor must be a compatible monitor and must be connected via USB to the Processor Unit.
⑥	 USER PROG	Selects user-programmed (P1 to P10) settings.
⑦		Enters the net shooting mark or own ship mark.

1. OPERATIONAL OVERVIEW

No.	Key/Control	Description
⑧		Enters an event mark 1 or own ship mark (horizontal mode).
⑨		Enters an event mark 2 or own ship mark (horizontal mode).
⑩		Enters a target lock mark. Shows/hides the estimate mark.
⑪		Shows/hides the estimate mark 1.
⑫		Shows/hides the estimate mark 2.
⑬		Deletes the mark highlight with the cursor.
⑭		Enters a fish mark 1.
⑮		Enters a fish mark 2.
⑯		Sets vertical cross section bearing.
⑰		
⑱		<ul style="list-style-type: none"> <li>• Selects the mode tab on the menu.</li> <li>• Selects mode (horizontal/vertical, horizontal/half-circle, horizontal/horizontal 2) to adjust sensitivity, select range, set tilt, and user program number.</li> </ul>
⑲		Automatic transducer train width on audio bearing mark (horizontal mode), vertical bearing mark (vertical mode).
⑳		Sets auto tilt angle.
㉑		Selects the display mode.
㉒		<p><b>Short press:</b> Opens the menu; goes back one layer in the menu.</p> <p><b>Long press:</b> Closes the menu.</p>
㉓		<ul style="list-style-type: none"> <li>• Shows the range/bearing audio marker.</li> <li>• Sets the audio bearing.</li> </ul>
㉔		Off centers (moves) the own ship symbol to the cursor location.
㉕		Adjusts the gain (sensitivity).
㉖		Changes the display range.

No.	Key/Control	Description
②7	 TILT	Sets the transducer tilt angle (based on sea surface).
②8		Perform assigned program/function.
②9	Speaker	Outputs audio for key operation, alerts and raise/lower completion.
③0	Trackball	<p><u>Trackball</u></p> <ul style="list-style-type: none"> <li>• Moves the cursor.</li> <li>• Highlights a menu item.</li> </ul> <p><u>Right button (short press)*<sup>1</sup></u></p> <ul style="list-style-type: none"> <li>• Opens the right-click pop-up menu.</li> <li>• Cancels the selected operation.</li> <li>• Goes back one layer in the menu.</li> <li>• Inserts an event mark (factory default settings)*<sup>3</sup>.</li> </ul> <p><u>Right button (long press)</u></p> <ul style="list-style-type: none"> <li>• Return the own ship mark to the center of the screen.</li> </ul> <p><u>Scrollwheel</u></p> <ul style="list-style-type: none"> <li>• <b>Spin</b>: Changes the value for settings.</li> <li>• <b>Spin</b>: Selects a menu item.</li> <li>• <b>Spin</b>: Adjusts tilt, range, gain and bearing.</li> <li>• <b>Spin</b>: Changes the selected User Program.</li> <li>• <b>Short press</b>: Confirms the selected item.</li> <li>• <b>Long press</b>: Opens the [Select Mark] window.</li> </ul> <p><u>Left button (short press)*<sup>1</sup></u></p> <ul style="list-style-type: none"> <li>• Confirms your selection.</li> <li>• Used with drag &amp; drop feature*<sup>2</sup>.</li> <li>• Inserts a fish mark (factory default settings)*<sup>3</sup>.</li> </ul> <p><u>Left button (long press)</u></p> <ul style="list-style-type: none"> <li>• Moves the cursor to the own ship location.</li> </ul>

\*1. This manual abbreviates the operation of the **left/right buttons** as follows:  
 “Press the **left button**” → “Left-click”; “Press the **right button**” → “Right-click”.

\*2. The operation of holding down the **left button** while moving the trackball is referred to as “drag & drop” in this manual

\*3. The following marks can be assigned to the **left/right buttons** as a shortcut. To change the default settings and assign a mark to either button, contact your local dealer for advice.

- Event marks 1 and 2
- Fish marks 1 and 2
- Estimate marks 1 and 2

1. OPERATIONAL OVERVIEW

1.1.2 Sub control unit (option)

The sub control unit lets you control the sonar from a remote location.

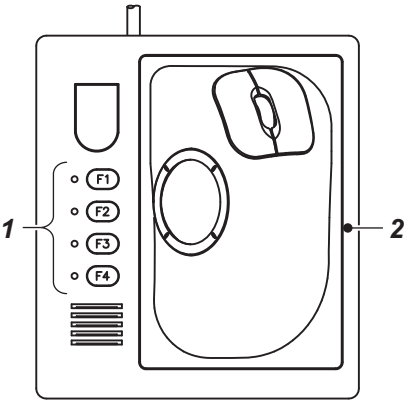
No.	Function (on control unit)	
1	Same as 1/F1 to 4/F4 key. (The program can be changed. See section 6.2.4.)	
2	Same as trackball unit on control unit.	

1.1.3 Remote controller (Option)

The optional remote controller can be used for the following operations (default settings shown) when you are away from the control unit.

**Note 1:** Do not leave the remote controller in an area subject to water splash and spray. When the remote controller is not in use, return it to its designated hanging location.

**Note 2:** Each key on the remote controller can be re-assigned with a different function (see section 6.4).

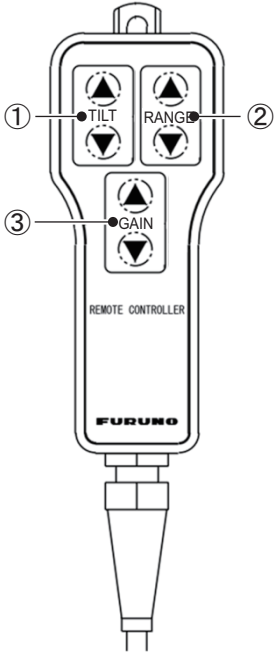
No.	Function (default)	
①	Same function as the TILT control on the control unit.	
②	Same function as the RANGE control on the control unit.	
③	Same function as the GAIN knob on the control unit.	

## 1.2 Turning the Power On/Off

### Turning the power on

Press the power switch (⏻). The lamp to the left of the power switch lights up. A beep sounds, and the display changes in the following sequence: FURUNO display → model display → board test display (see section 9.11.2). Then the lamp beside the switch changes as below. The last-used mode is activated in approximately 140 seconds after turning the power on.

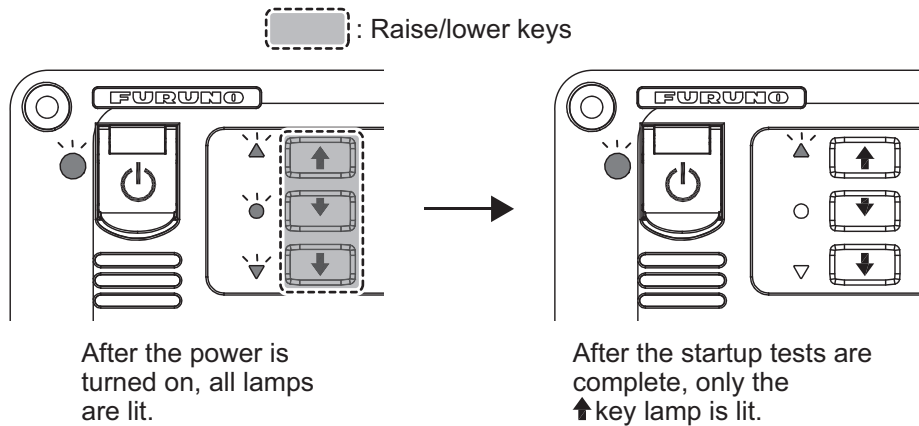

### Turning the power off

1. First retract the transducer with the ↑ key. The lamp to the left of the ↑ key flashes while the transducer is being raised and lights steadily when it is fully raised.  
**Note:** While raising the transducer, the ship speed must not exceed 15 knots, to prevent damage to the transducer and hull unit.
2. After the ↑ key lights steadily, press the power switch (⏻) until the screen goes blank.

If the power switch (⏻) is pressed before retracting the transducer, the message "Raising ↑" appears and the transducer is retracted. However, for safety purposes, make it a practice to retract the transducer before turning off the power.

## 1.3 Raising/Lowering the Transducer

**⚠ CAUTION**

**Maximum speed while the transducer is projected and being raised or lowered is as below, to prevent damage to the transducer.**

Transducer stopped	Raising / Lowering
18 knots	15 knots

**⚠ CAUTION**

**The transducer is stopped whenever the emergency stop button on the hull is operated or the ratchet (for manual raising) is removed from its holder in the hull unit.**

A message appears and the transducer cannot be raised or lowered. Re-set the emergency stop button or return the ratchet to its holder to release the emergency stop condition.

### 1.3.1 Lowering the transducer

With the boat at the fishing ground and the power on, press the ↓ key to lower the transducer. The lamp to the left of the key flashes during lowering and the message "Lowering ↓" appears at the bottom of the screen. When the transducer reaches the water, the message "TX Start" appears and transmission begins automatically. After the transducer is fully lowered the lamp the left of the key lights steadily. You can see the position of the transducer by watching the transducer mark at the top left corner on the screen. See section 1.3.3.

In normal use, fully lower the transducer. The time required to fully lower the transducer is indicated in the following table.

Stroke	Time (seconds)
800 mm	8
1100 mm	11

If the transducer becomes entangled in the net for some reason, partially raise the transducer with the ↕ key. The function of the ↕ key depends the menu setting (main menu → [Others] → [Mid Key Setting]).

**[Fixed Position]:** The transducer stops at the selected position. If the ↕ key is operated while the transducer is being raised or lowered, the transducer stops at the fixed position. The fixed position can be set by clicking the transducer position marker. See the next page.

**[Any Position]:** The transducer starts lowering when the ↕ key is operated. The lowering is stopped when the ↕ key is operated. To raise or lower the transducer from the current position, use the ↑ or ↓ key. The ↕ key does not control lowering or raising of the transducer.

You can see the approximate position of the transducer with the transducer position marker (see section 1.3.3). When the transducer is stopped before it reaches full protrusion, the lamp to the left of the ↕ key lights steadily.



### 1.3.2 Raising the transducer

Press the **↑** key to raise the transducer. The lamp to the left of the switch flashes and the message "Raising **↑** (back color: green)\*" flashes on the screen while the transducer is being raised. When retraction begins, the transmission is stopped and the message "TX STOPPED" appears on the screen. When the transducer is completely retracted, the message "RETRACTED" appears and the lamp to the left of the **↑** key lights steadily.

\*: When raising the transducer automatically by pressing power switch (**⏻**), the back color is red.

**Note:** If the transducer is not raised within approx. 16 seconds (800 stroke) or 22 seconds (1100 mm stroke) the message "TRANSDUCER NOT RETRACTED" appears. If this occurs, see "How to raise the transducer manually" on page 9-18 for how to retract the transducer manually.

### 1.3.3 How to check transducer protrusion

The [Transducer Position Mark], which appears at the top left corner, lets you check how far the transducer is protruding. You can show or hide the marker by doing the following operation: Main menu → [Others] → [Initial Settings] → [Mark Display] → [TD Position Mark].

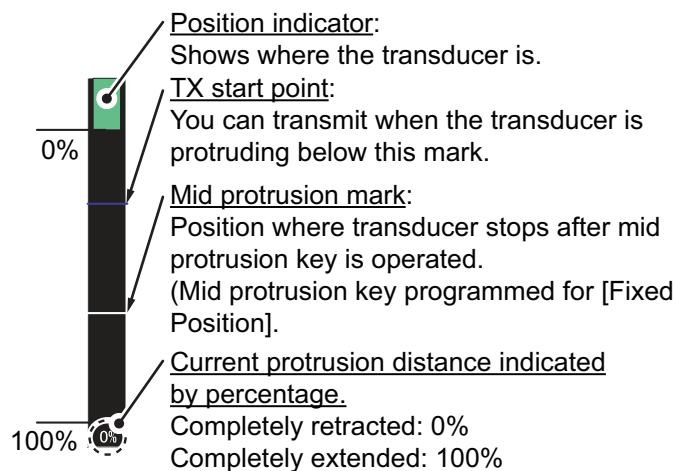

The color of the indicator changes according to transducer position and operation state.

- Green: The transducer is fully retracted.
- Brown-yellow: Transducer stopped at position other than "retracted".
- Red: The transducer is being raised or lowered.

**Note:** If the transducer position cannot be detected the transducer mark flashes. Further, the bar is not displayed, and the amount of protrusion is indicated as "\*\*%".

### How to set mid position

With [Mid Key Setting] in the [Others] menu set to [Fixed Position], click the transducer position mark to show the window shown in the right figure. Click ▲ or ▼ to change the setting. Click [Quit] to close the window.

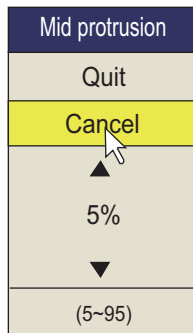

## 1.4 Screen Brilliance and Panel Dimmer

### How to adjust the screen brilliance

If your monitor is FURUNO and the monitor is connected to the processor unit via USB, you can adjust the screen brilliance from the control unit. Turn the **BRILL** knob clockwise to increase, or counter-clockwise to decrease, the brilliance.

**Note:** If your monitor is not FURUNO, brilliance cannot be adjusted from the control unit. Adjust the brilliance at the monitor.

### How to adjust the panel dimmer

You can change the brightness of the panel and keys with the following procedure.

1. Press the **MENU/ESC** key to open the menu.

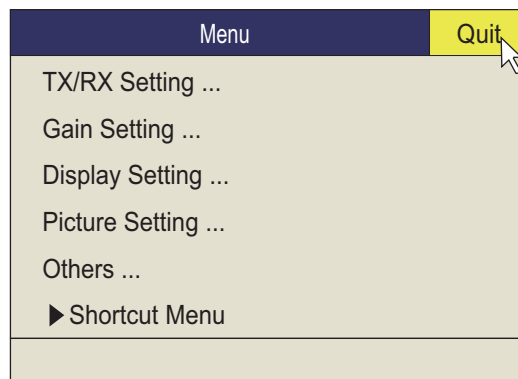

2. Roll the trackball to select [Others] then push the left button.

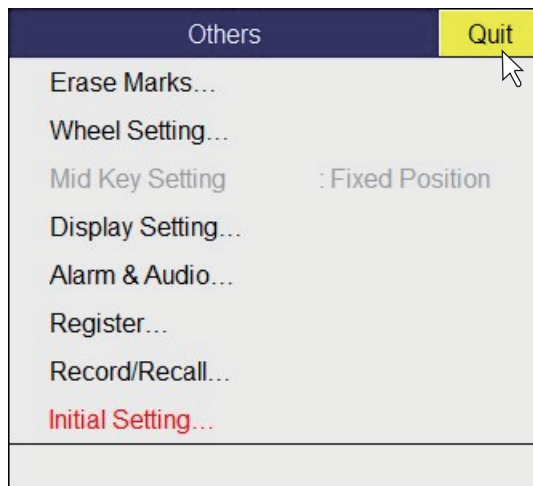

3. Click [Display Setting].

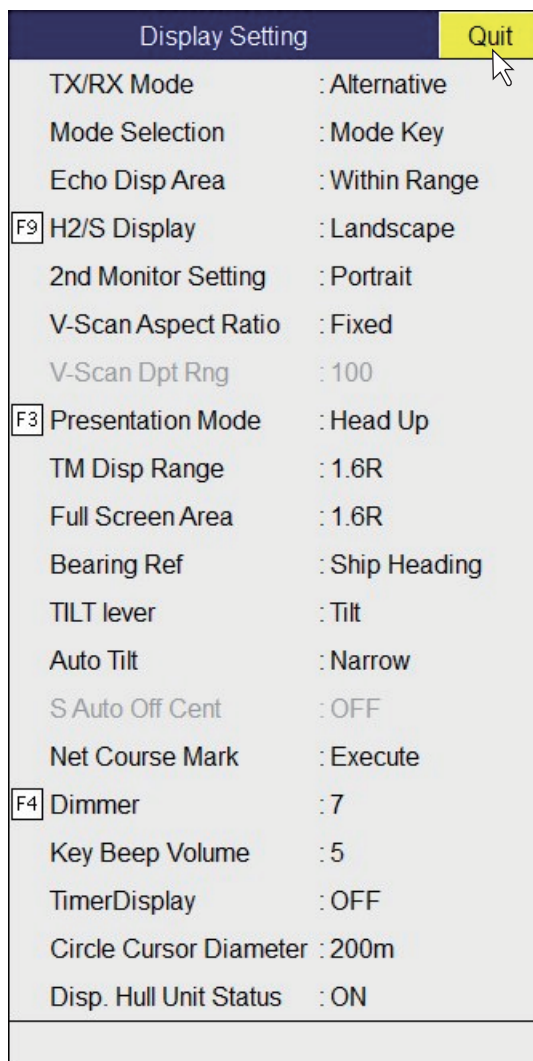

## 1. OPERATIONAL OVERVIEW

- Click [Dimmer] to show the setting box.

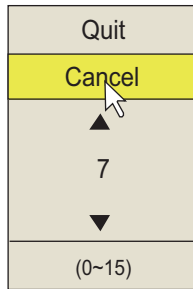

- Click ▲ (increase) or ▼ (decrease) to select a value.
- Left-click several times to change the settings.
- Long-press the **MENU/ESC** key to close all menus.
- Press and hold the **MENU/ESC** key until the menu closes.  
**Note:** With factory default settings, you can use the shortcut keys 8/F8 to adjust the panel dimmer.

## 1.5 Display Modes

There are six display modes; Horizontal, Horizontal1 + Horizontal2\*, Slant (single display), Horizontal + Slant\*, Vertical1\* and Vertical 1 + Vertical 2\*.

\*: If the FSV-85 MARK-2 is fitted with dual monitors, you can select how the picture data is shown on two displays; Dual Display or Sub Display. For details, see "2nd Monitor Setting" on page 7-8.

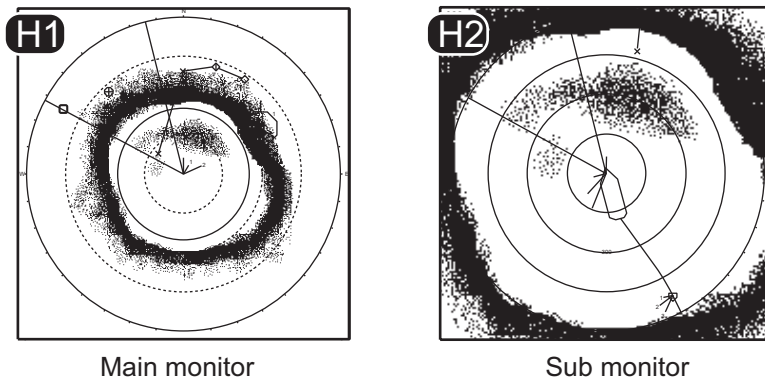

*Ex; Dual Display (H1 + H2 mode)*

## Display format

The on-screen display area is comprised of a data display area and an echo display area. You can select one of two display formats, as indicated below. One shows the echoes with the outermost range ring as the boundary, the other shows echoes in a full-screen display. The full-screen format allows you to view echoes which would otherwise require a change in range. For more information about the data display area, see chapter 6.

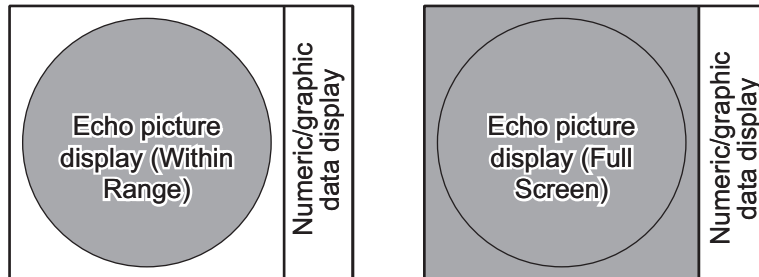

### 1.5.1 How to select a display mode

Press the **MODE** key several times until the desired display appears. The default modes are Horizontal, Horizontal1 + Horizontal2, Vertical1 and Vertical1 + Vertical2. You can program the **MODE** key to show any or all of the modes mentioned above. For further details, see "Display Mode" on page 7-6.

The **MODE** key may be programmed to show a pull-down menu instead of a conventional menu.

1. Push the right-click button on the numeric/graphic data display.

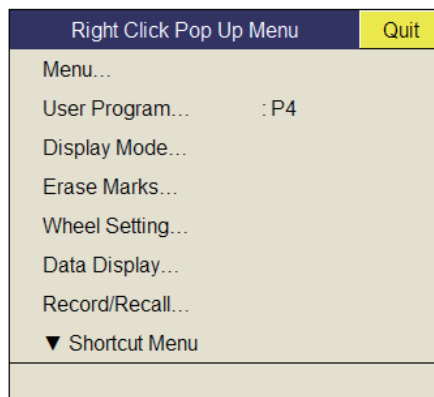

2. Select [Display Mode] then push the left-click button.

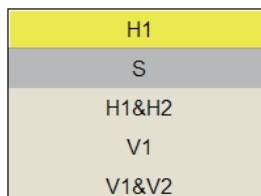

3. Select the mode to display then push the left-click button.

## 1.5.2 Display mode pictures

Below are typical pictures. For sake of brevity, indications and marks are not shown.

### Horizontal mode

This mode provides 360-degree coverage around the vessel and it is useful for general search. For further details, see chapter 2.

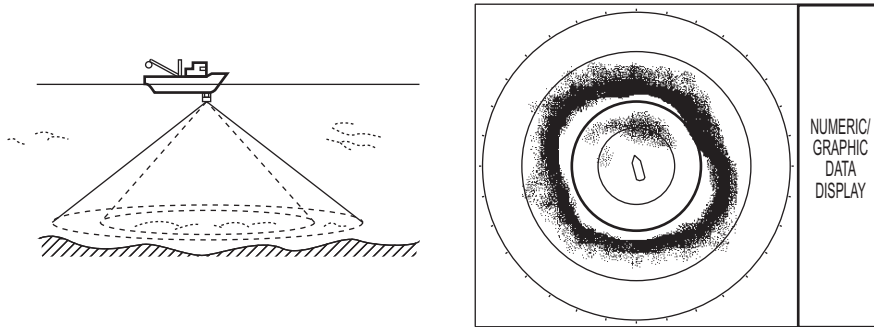

*Horizontal mode*

### H2 mode

This mode provides two horizontal screens (H1 and H2) in one of the configurations shown below. The default configuration, Landscape, shows two horizontal displays, one up and one down. Other configurations available are as shown below. Desired configuration may be chosen with H2/S2 Display in the [Display Setting] menu. For further details, see chapter 2.

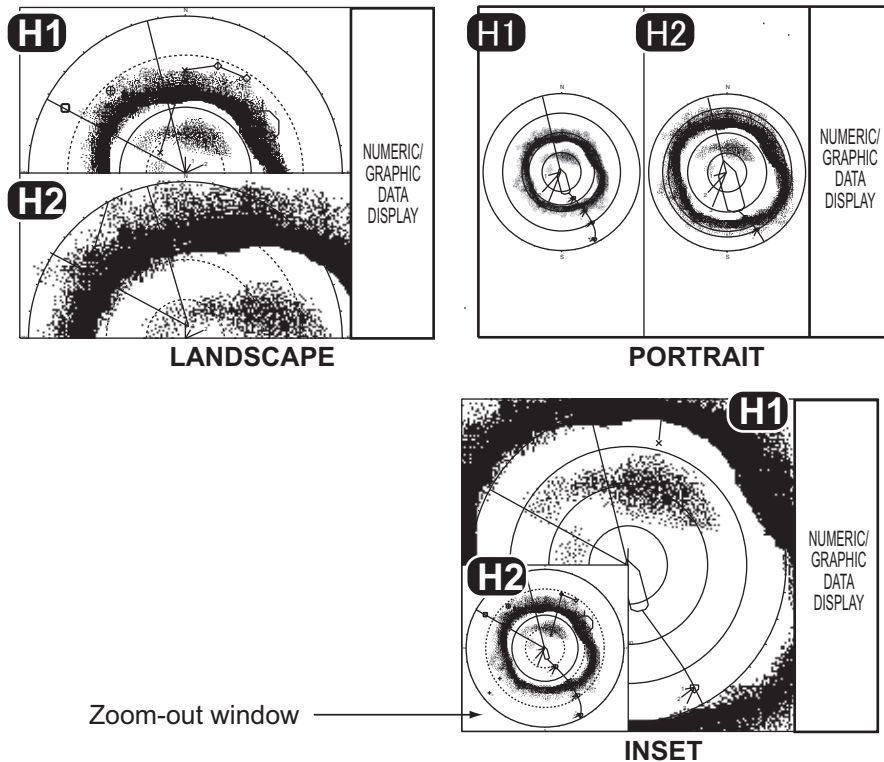

*H2 mode*

**Slant mode, single display**

The Slant mode shows a 180-degree cross section, using chosen tilt angle and train setting. For further details, see chapter 4.

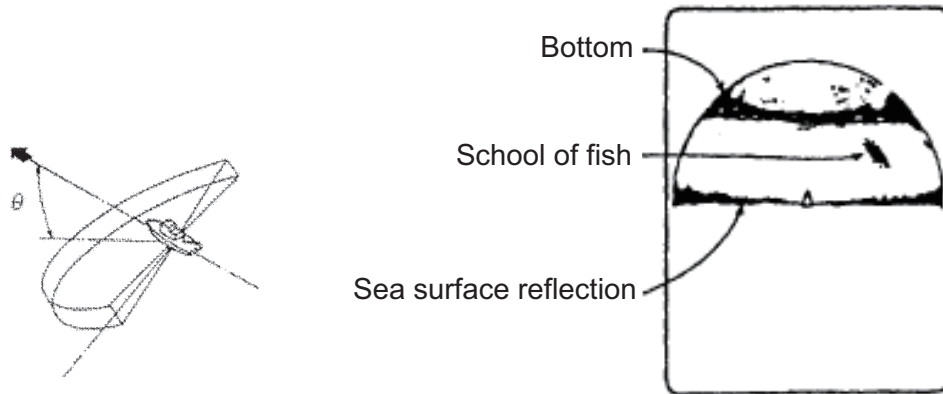

*Slant mode (single display)*

**H and S mode**

This mode provides horizontal and slant modes in one of the configurations shown below. The default configuration, Landscape, shows two horizontal displays, one up and one down. Other configurations available are as shown below. The desired configuration can be chosen with H2/S Display in the [Display Setting] menu. For further details, see chapter 4.

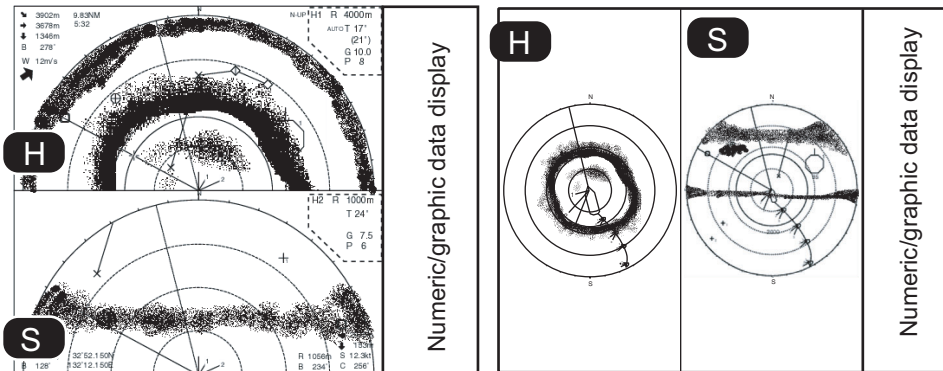

Landscape display (Slant mode on bottom half) Portrait display (Slant mode at right half)

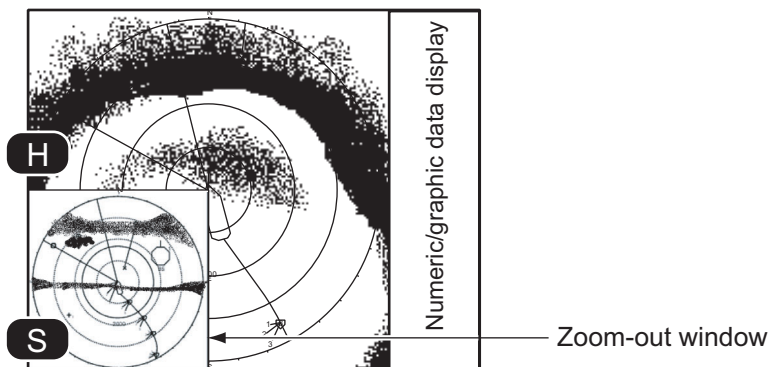

Slant mode in inset

# 1. OPERATIONAL OVERVIEW

## V1 and V2 modes

The V1 and V2 modes show a vertical slice of the bearing selected by the vertical bearing mark on the horizontal display. The vertical 2 mode provides two vertical slices. For further details, see chapter 3.

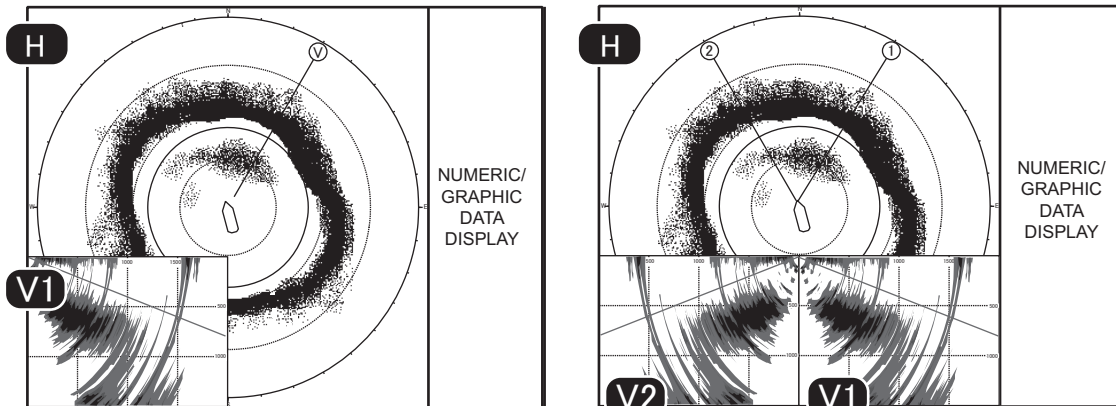

V1 mode

V1 & V2 mode

## 1.6 Software Function Keys

You can see the current setting for each software function key. Put the cursor at the bottom of the screen for approx. two seconds to show the settings. Left click a function to get the corresponding action. See subsection 6.2.2.

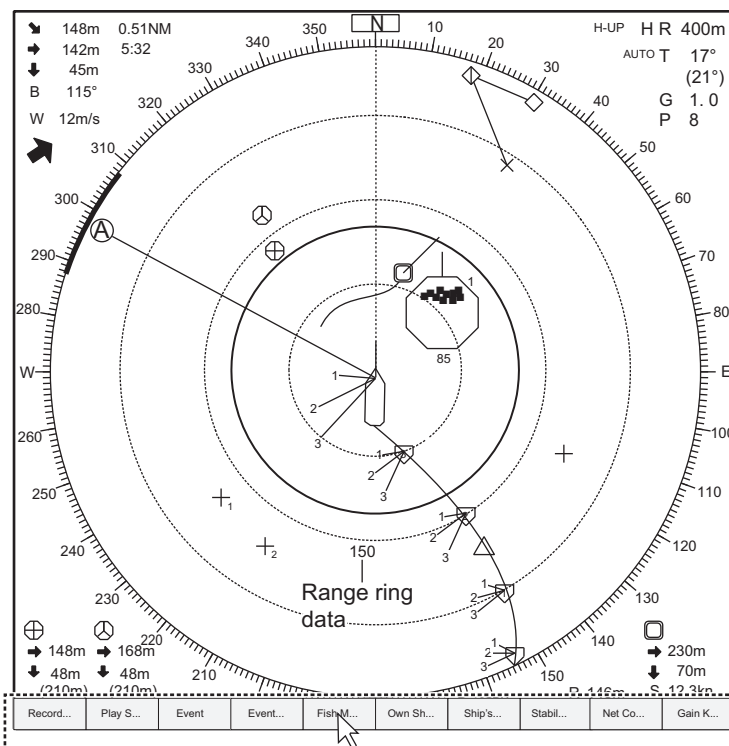

Software function key

You can do the functions assigned to function keys 1/F1 to 0/F10 (from left).

Shortcuts are display in numerical order. **1/F1** key's function appears at the left end and **0/F10** key's function appears at the right end.

Left click a function to get the corresponding action. See section 6.2.2 for how to change the function assigned to each key.



## 1.7 How to Adjust the Gain

The **GAIN** knob adjusts receiver gain (sensitivity). Adjust it so fish echoes are clearly displayed with minimal noise on the screen. Too high a gain setting not only displays excess noise and makes it difficult to discriminate wanted echoes but also causes bottom echoes to be painted in strong colors, resulting in echoes being masked by bottom reflections. Normally, set the control somewhere between positions 3 and 7.

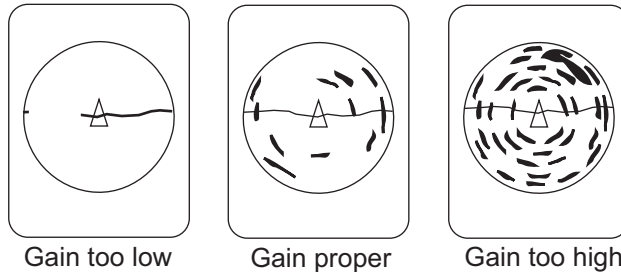

1. If the horizontal and vertical modes are active, press the **H/V/S** key to show the range and gain indications of the mode you wish to adjust. Pressing the **H/V/S** key changes the color of the range and gain indications to orange.
  - H1/H2: Horizontal1 or horizontal2
  - V1/V2: H or V display
2. Adjust the **GAIN** control.

New gain setting is momentarily displayed in large characters at the top of each display. The setting value is always displayed next to "G". (For the vertical display, the gain indication is shown at the bottom of the display.)

**Note:** The gain can also be adjusted from the gain indication. Put the cursor on the gain indication to highlight it in yellow then roll the scrollwheel.

# 1.8 How to Use the Menu

Most operations are carried out from the menu. This section provides basic menu operating information.

1. Press the **MENU/ESC** key to open the main menu.

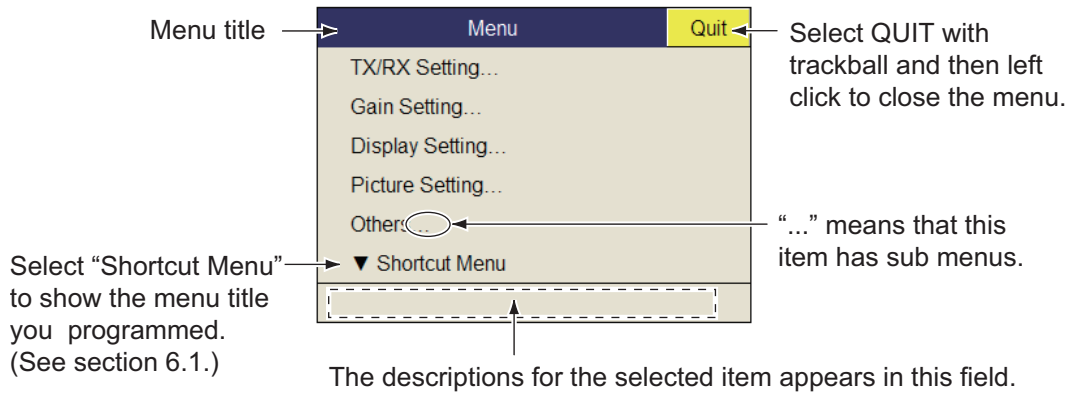

**Note:** You can also show the main menu by pushing the right-click button to show the pop-up menu. See "Pop-up menu operation" on page 18.

2. Operate the trackball to place the arrow cursor on the item you want to select. The yellow cursor marks the current selection. You can also use the scrollwheel to select a menu item.
3. Left-click or press the scrollwheel button when selected with the scrollwheel. If you selected [TX/RX Setting] at step 2 for example, the following menu appears.

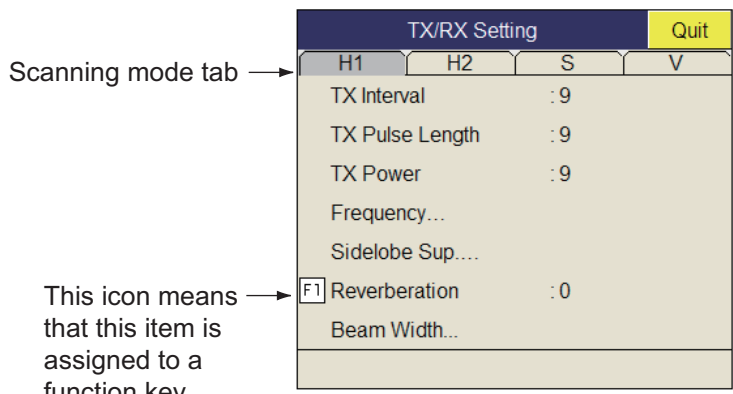

4. Press the **H/S/V** key to select the display mode.
  - H1, H2 tab: Items for horizontal display setting
  - S tab: Items for the slant display setting
  - V tab: Items for the vertical display setting

Items which you cannot set are shown in gray.
5. Select the item then push the left-click button.

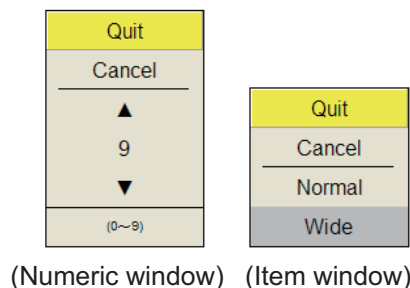

6. Select the setting.
  - (Numeric) Select ▲ to increase the value then push the left-click button (or roll the scrollwheel upward). To decrease the value, select ▼ and push the left-click button (or roll the cursor scrollwheel downward).
  - (Items) Select an item then push the left-click button.
7. Select [Quit] on the setting box then push the left-click button to close the box. If you want to cancel the setting, select [Cancel].
8. Long-press the **MENU/ESC** key to close all menus.  
You can also close all menus by selecting [Quit] on the active menu and Long-pressing the left-click button.

**Note 1:** You can relocate menu windows. Use the trackball to put the arrow cursor on the menu is title (blue when menu is active), push the left-click button, drag window to new location then release the left-click button. The position of the menu windows is saved.

**Note 2:** In the default setting, the sub menu item [Initial Setting] in the [Others] menu and some items in the [Initialization] menu are shown in red. This means these items are locked to prevent accidental change of setting. When you open

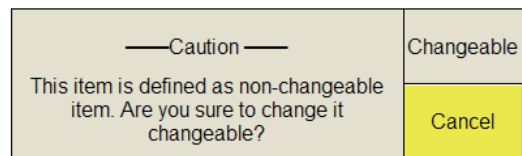

one of these sub menus and select an item, the confirmation message shown above-right appears. To change the setting of the selected item, select [Changeable] and push the left-click button to show the dialog box for the item. To escape, select [Cancel] then press the left button.

If you do not want to show the confirmation message above, see "Initialization menu" on page 16.

**Note 3:** If two menu items are functionally related, the setting of one menu item causes restriction to another menu item. In this case, the equipment ignores both settings to use different ones or invalidates the setting of the item encountering restriction. The invalid setting value or menu item is shown in gray.

**Note 4:** When displaying multi-layered menus, the echo screen may become covered by the menu boxes. You can adjust the menu transparency using the [Menu Box Transp.] options in the [Initial Setting] menu. (Refer to section 7.6.)

**Note 5:** When a lower layer menu is closed, the pointer position will return to the position it was in when the lower layered menu was opened.

**Note 6:** If the cursor location becomes hard to find, you can reset it to the same location as the own ship mark by opening then closing the menu. Press the **MENU/ESC** key twice.

## 1. OPERATIONAL OVERVIEW

### **Pop-up menu operation**

Push the right-click button on the numeric/graphic data display to show the pop-up menu. These items can be accessed from the main menu.



# 2. HORIZONTAL MODE

## 2.1 Basic Operating Procedure

**1** Turn the power on.

**2** Lower the transducer.

- **If the mid protrusion key is programmed to [Fixed Position]:**  
Lowers the transducer to half protrusion.
- **If the mid protrusion key is programmed to [Any Position]:**  
The transducer stops at desired position.

↓ Lowers the transducer to full protrusion.

**3** Select horizontal display.

**4** Press to choose the screen (horizontal or vertical or horizontal1 or horizontal2) to adjust gain and range.

**5** Set the display range.

**6** Adjust the gain.

**7** Set the tilt angle.

## 2.2 Horizontal Display Overview

### 2.2.1 Horizontal mode, full-screen display

The full-screen horizontal display provides a 360° picture around the boat. To display the full-screen horizontal picture, press the **DISP MODE** key.

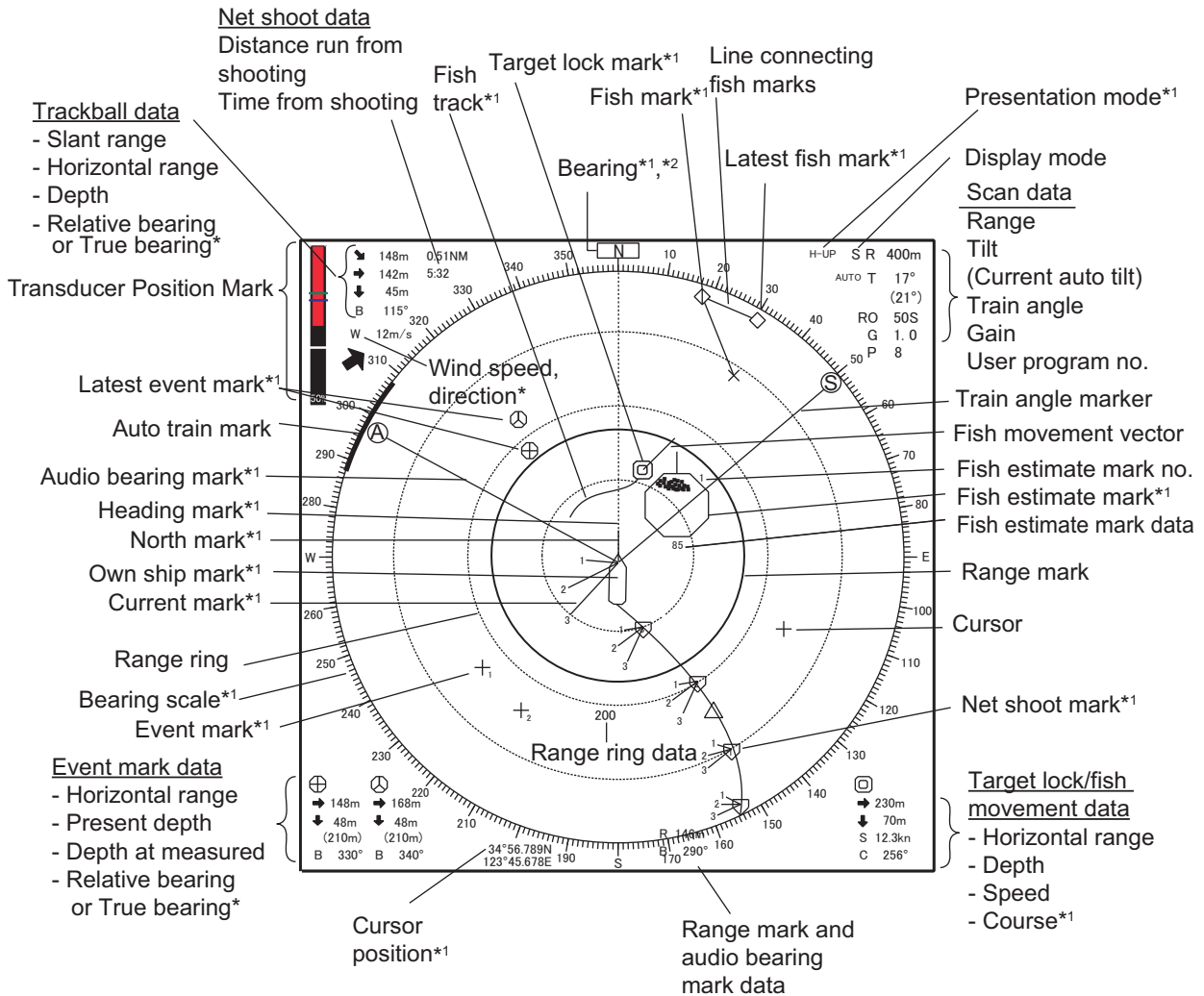

**Note 1:** When the settings listed below are changed, the setting value is shown at the top of the display for five seconds.

- Gain (See section 1.7.)
- Tilt angle (See section 2.4.)
- Automatic training (See section 2.13.3.)
- Display range (See section 2.3.)
- Automatic tilt (See section 2.4.2.)
- User program (See section 6.3.1.)

**Note 2:** The color of the event mark, fish mark, and fish estimate mark can be changed on the menu: main menu → [Others] → [Initial Setting] → (Change confirmation window) → [Mark Display] → [Mark Color].

## 2.2.2 Horizontal2 mode

The H2 mode shows one of three kinds of horizontal display combinations: Landscape, Portrait or Inset as shown on page 12. Follow the procedure shown below to select a combination display. The zoom-out display (shown on the inset mode) can be moved by drag and drop operation and its size changed from the menu. To show the horizontal2 mode display, press the **MODE** key and select [H2].

1. Press the **MENU/ESC** key to show the main menu.
2. Click [Others].
3. Click [Display Setting].

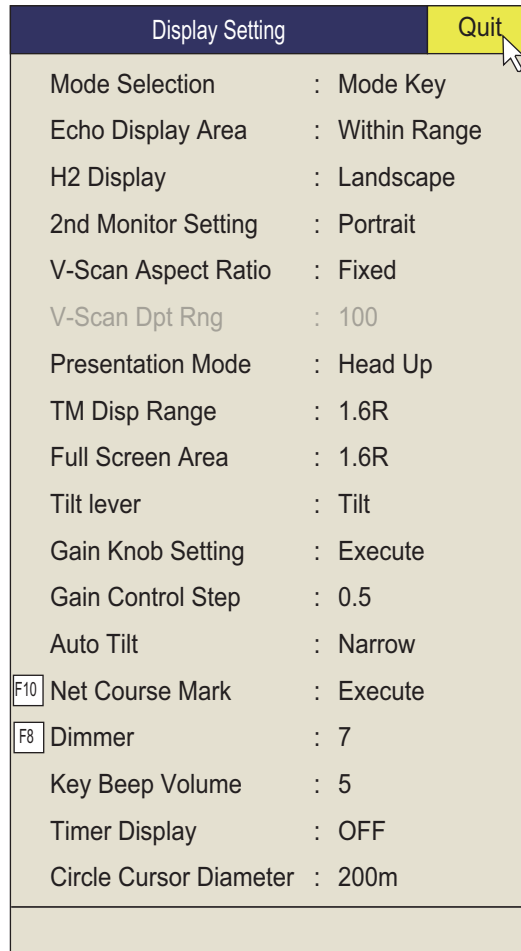

4. Click [H2 Display].

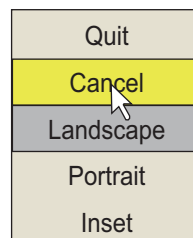

5. Click the desired option.
6. Click [Quit] on the setting box to close the box.
7. Long-press the **MENU/ESC** key to close all menus.

**Note:** Range, tilt angle, gain and program keys can be adjusted separately for each horizontal display.

## 2.3 Display Range

The **RANGE** control selects the detection range and six ranges are preset at the factory. The range selected is momentarily displayed in large characters at the top of the screen. Range is always displayed next to “R” at the top right of the screen.

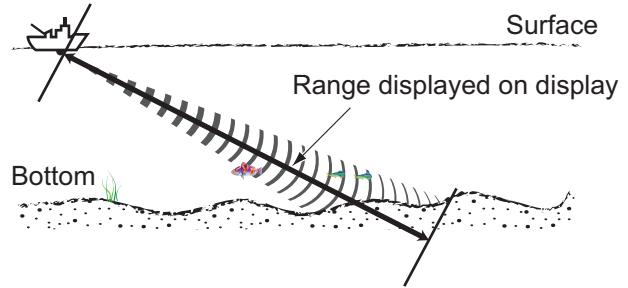

*Default settings for the display range (unit: m)*

Range No.	1	2	3	4	5	6
Detection range	100	200	400	600	800	1000

**Note:** Ranges can be preset at the [H-Scan Range] on the [Others] - [Register] menu. See page 7-6.

1. If the vertical or slant display is active, press the **H/V/S** key to select the horizontal display. If the two horizontal displays are active, press the **H/V/S** key to select H1 or H2 to change the range. The range and gain indications of the horizontal mode must be in orange to change the range (and gain).
2. Operate the **RANGE** control to select a range.

**Note 1:** The range can also be adjusted from the range indication. Put the cursor on the range indication to highlight it in yellow then roll the scrollwheel.

**Note 2:** In the target lock function, the range is automatically changed according to target position if [Tilt Interlock] on the [Target Lock] menu is selected to [Tilt & Range].



## 2.4 Tilt Angle

The tilt angle shows the direction to which the sound wave is emitted. When the sound wave is emitted horizontally, the tilt angle is said to be 0° and when vertically, 90°. The tilt angle can be set between -5° (upward) to 60° (downward), in increments of 1°. The tilt angles for horizontal 1 and horizontal 2 modes can be set independently of one another.

### 2.4.1 How to set the tilt angle

To set a tilt angle manually, operate the **TILT** control. Watch the tilt angle indication and tilt angle indicator at the top right corner of the screen. The tilt angle is shown next to "T" at the top right corner of the screen.

Select tilt angle depending on target fish. For surface fish select a shallow angle (about 5°) and for bottom fish, a deep angle.

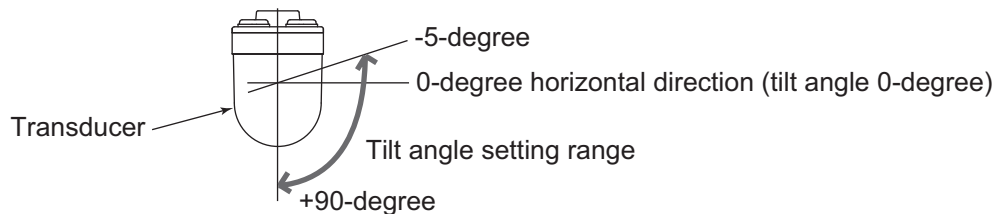

**Note 1:** In the factory default condition, the tilt angle can also be adjusted by rolling the scrollwheel.

**Note 2:** The tilt angle can also be adjusted from the tilt angle indication. Put the cursor on the tilt angle indication to highlight it in yellow then roll the scrollwheel.

**Note 3:** The **TILT** control functions as a bearing setting lever when the following conditions are met: [Tilt Lever] in the [Display Setting] menu is selected to [Tilt & V1], and the vertical display is chosen in the vertical mode.

### 2.4.2 Automatic tilt

The **AUTO TILT** key automatically scans the tilt angle within the selected width. This is useful when you want to find the center depth of a school of fish. Wide tilt angle is activated from the [Auto Tilt] on the [Others] - [Display Setting] menu.

1. Press the **AUTO TILT** key to select auto tilt angle desired. Each time the key is pressed the auto tilt angle changes in the following sequence.

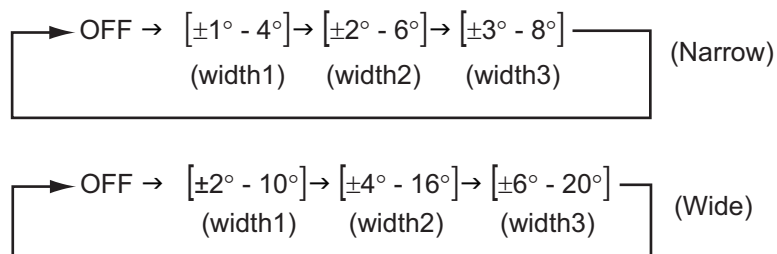

## 2. HORIZONTAL MODE

- If necessary operate the **TILT** control to change center tilt angle.  
In automatic tilt, "AUTO" is displayed at the top right corner. To disable automatic tilt, select OFF at step 1.

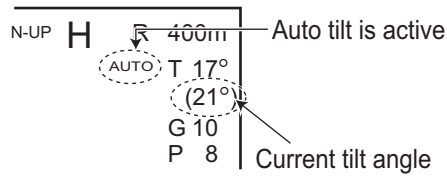

*Automatic tilt angle (narrow) with **AUTO TILT** key*

Range (m)	Width 1	Width2	Width3	Period
60, 100	±4°*	±6°*	±8°*	Period: One transmission <b>Note:</b> Tilt angle changes in 2° increments for asterisk-marked width; 1° increments for all other widths.
150, 200	±2°	±4°	±6°*	
300, 400	±1°	±2°	±4°*	
500, 600	±1°	±2°	±3°	
700, 800	±1°	±2°	±3°	
900, 1000	±1°	±2°	±3°	
Over 1100	±1°	±2°	±3°	

*Automatic tilt angle (wide) with **AUTO TILT** key*

Range (m)	Width 1	Width2	Width3	Period
60, 100, 150	±10°	±16°	±20°	Period: One transmission
200	±10°	±16°	±20°	
300, 400	±10°	±16°	±20°	
500, 600	±8°	±16°	±20°	
700, 800	±6°	±12°	±16°	
900, 1000	±4°	±8°	±12°	
Over 1100	±2°	±4°	±6°	

For example, when the **RANGE** control, **TILT** control and **AUTO TILT** key are set to 800 m, 8° and width (1) respectively, the tilt angle changes at each transmission as follows: 8° → 9° → 8° → 7° → 8°.

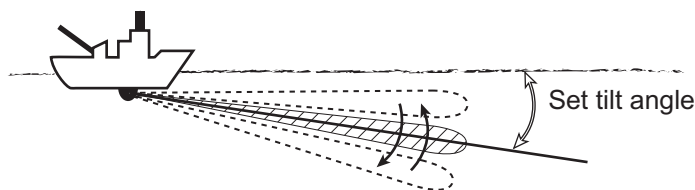

**Note 1:** The **AUTO TILT** key is inoperative when the target lock function is active or is made active. Auto tilt is available when the target lock is OFF.

**Note 2:** If the picture set with auto tilt is not visible, disable auto tilt and try again.

### 2.4.3 Relation between bottom echo and tilt angle

The figure below illustrates how two schools of fish "a" and "b" are displayed on the screen using three different tilt angles.

**Case 1: Tilt angle 30° to 40°:** This tilt angle will display the entire bottom since it is captured by the full width of the beam. The school of fish is obscured by the bottom.

**Case 2: Tilt angle 10° to 20°:** This tilt angle will only display half the bottom since it is captured by only the lower half of the beam. The school of fish is located above the bottom.

**Case 3: Tilt angle 0° to 5°:** This tilt angle may or may not capture the bottom since the returning bottom echo is weak. The school of fish is located close to the bottom.

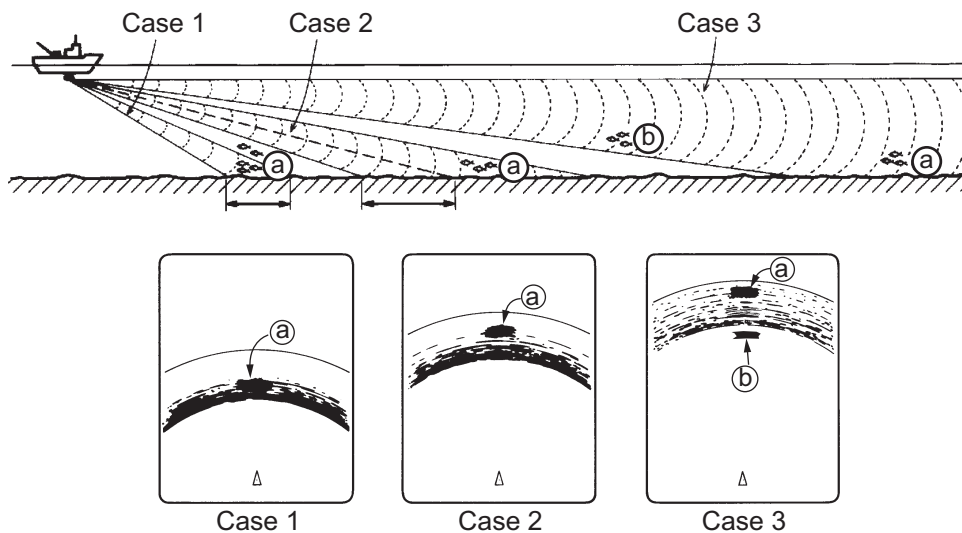

#### Points to consider

- Normally, a vertically distributed school of fish is a better sonar target than the bottom, because it reflects the transmitted pulse back toward the transducer.
- In case 3, both schools of fish "a" and "b" are presented. Generally speaking, however, midwater schools of fish tend to be larger than schools of fish on the bottom and they are often displayed near the bottom on the display.
- It is difficult to detect bottom fish when they are not distributed vertically.

### 2.4.4 Tilt angle for surface fish

The sound emitted from the sonar transducer forms a beam with a width of approximately  $10^\circ$  in the vertical direction (vertical beam width at -6 dB). The tilt angle indicates the angle between the centerline of the beam and the horizontal plane. Then, if the tilt angle is set to  $0^\circ$ , the centerline is parallel with the sea surface and one half of the emitted sound goes upward, toward the sea surface.

This causes one half of the emitted sound to be reflected toward the transducer and displayed on the screen as sea surface reflections. When the sea is calm, since the sound is reflected just like a light hitting a mirror at a low incident angle, it propagates away and the sea surface reflections become negligible.

However if the sea is not calm enough, they will become dominant and interfere with observation of wanted echoes. To minimize these sea surface reflections and to search for schools of fish on the surface effectively, the tilt angle is usually set between  $4^\circ$  and  $5^\circ$  so the upper portion of the beam becomes almost parallel with the sea surface. When the sea is rough, the tilt angle is slightly increased to lessen the affect of sea surface reflections.

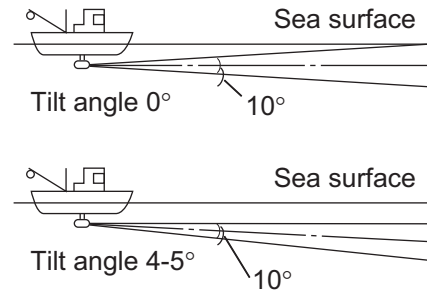

### 2.4.5 Suitable tilt angle

The figure below illustrates the relationship among tilt angle, depth and detection range. Refer to it to find out the suitable tilt angle for a given depth/detection range.

Tilt angle setting: relationship between tilt angle and detection range

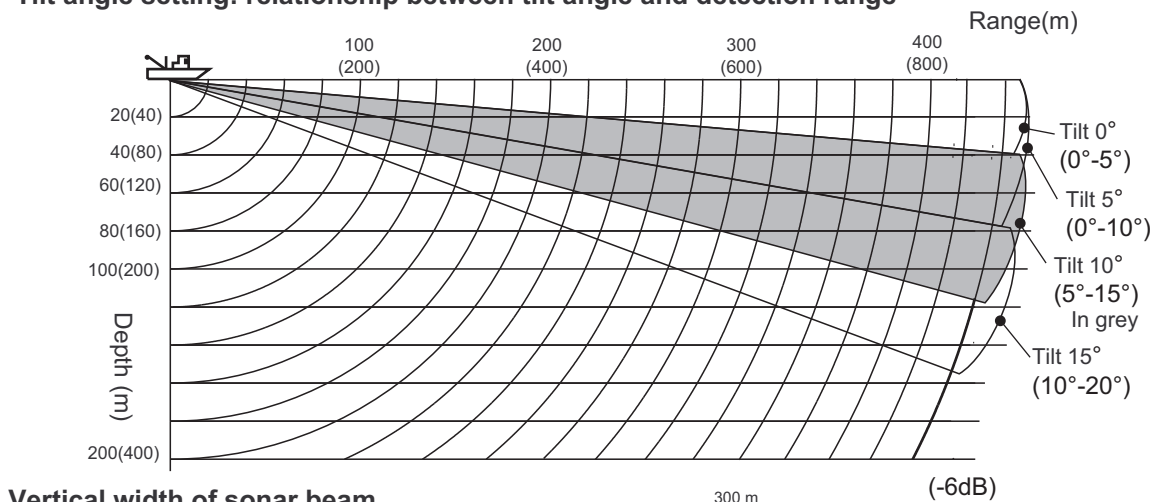

Vertical width of sonar beam

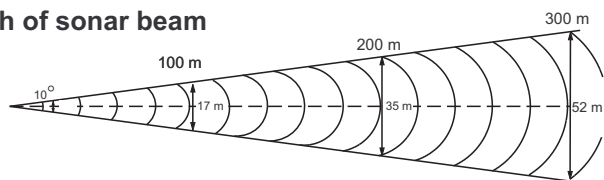

Tilt angle and beamwidth (80kHz)

## 2.5 How to Measure Range and Bearing to a Target

Operate the trackball to place the cursor on the target you want to measure the range and bearing. The range, bearing and depth to the target appear at the upper left corner of the screen.

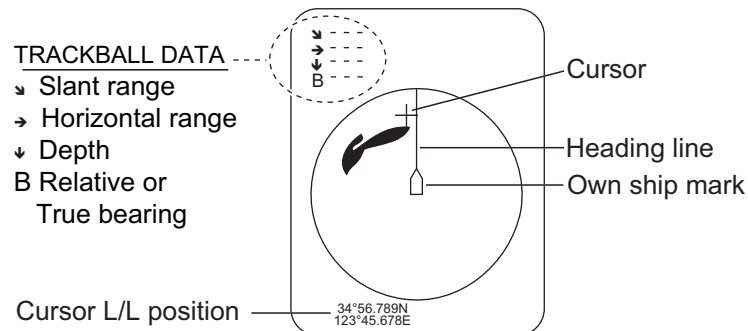

**Note 1:** Trackball position may also be shown in latitude and longitude. For further details, see page 7-9.

**Note 2:** The bearing display is available in four formats. See page 7-9.

## 2.6 How to Eliminate Weak Echoes

Echoes from targets such as bottom and fish return to the transducer in order of distance to them, and when we compare their intensities at the transducer face, those from nearer targets are generally stronger due to little propagation attenuation and little absorption. If these echoes are displayed directly on the screen, the size of the displayed echo from the same school of fish may change with distance, making it difficult to judge the actual size of the school of fish. To overcome this inconvenience use the TVG curve function. This function compensates for propagation loss of sound in water; amplification of echoes on short range is suppressed and gradually increased as range increases so that similar targets are displayed in the similar intensities irrespective of the ranges to them.

### TVG curve

Four TVG curves are available and they vary the gain from large to small.

1. Press the **MENU/ESC** key to open the main menu.
2. Select [Gain Setting] then push the left-click button.

## 2. HORIZONTAL MODE

- Press the **H/V/S** key to select the [S] tab.

Gain Setting			Quit
H1	H2	S	V
TVG-Near		: 5	
TVG-Medium		: 5	
TVG-Far		: 2	
TVG Distance...			
Sel. TVG Curve		: TVG 3	
AGC		: 0	
Near AGC...			
2nd AGC...			
Absorption Coeff.		: 26.5dB	
Gain Control		: Wide	

- Select [Sel. TVG Curve] then push the left-click button.

Quit
Cancel
TVG 1
TVG 2
TVG 3
TVG 4

- Select a curve then push the left-click button.  
The smaller the number, the gentler the gain change over distance.
- Select [Quit] on the setting window then push the left-click button to close the box.
- Long-press the **MENU/ESC** key to close all menus.  
The TVG is also used to suppress unwanted echoes (sea surface reflections, cruising noise, etc.) on near ranges. If the selected curve does not provide satisfactory results, try to adjust [TVG-Near], [TVG-Medium] or [TVG-Far], as shown below.

### **TVG distance and setting**

This sonar has three TVG functions, NEAR, MEDIUM and FAR, and they mainly compensate for propagation loss on short, middle and long ranges respectively, centered at the ranges shown below. The higher the TVG setting, the greater the amplification of echoes.

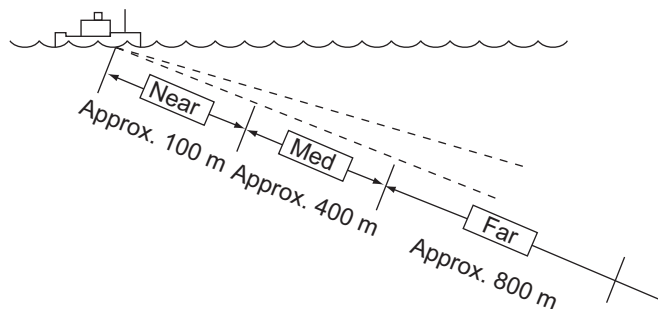

- Press the **MENU/ESC** key then push the left-click button to open the main menu.
- Select [Gain Setting] then push the left-click button.
- Press the **H/V/S** key to select [H1] or [H2] tab.
- Select [TVG Distance] then push the left-click button.

5. Select [Changeable] then push the left-click button.

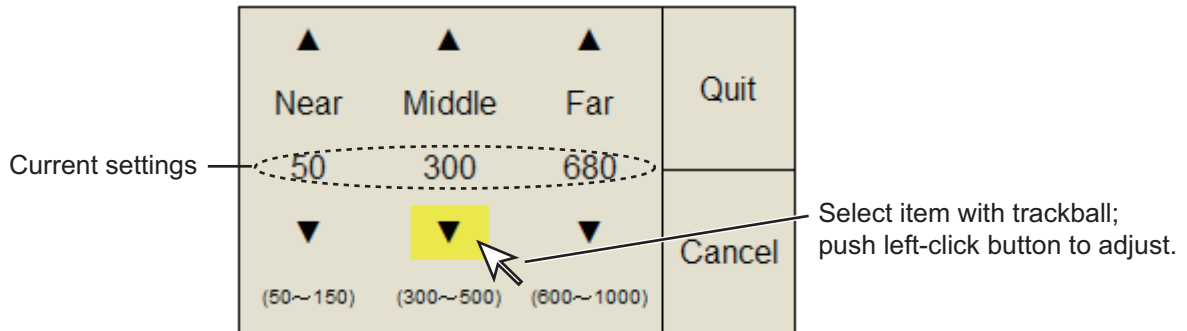

6. Select [Near], [Middle] or [Far] as appropriate then push the left-click button to change the setting.  
Near: Setting range, 50 - 150 m, 10 m increments. Middle: Setting range, 300 - 500 m, 20 m increments Far: Setting range, 600 - 1000 m, 40 m increments
7. Select [Quit] on the setting box then push the left-click button.  
Adjust the TVG level for selected TVG distance as follows.
8. Select [TVG-Near], [TVG-Medium] or [TVG-Far] as appropriate then push the left-click button.
9. Select ▲ or ▼ as appropriate then push the left-click button to change the setting.  
The setting range is -5 to 5. The higher the setting value, the higher the gain. For strong echoes, such as sea surface reflections or plankton, lower the setting by 1 or 2.
10. Select [Quit] on the setting box then push the left-click button.
11. Long-press the **MENU/ESC** key to close all menus.  
**Note:** When a school of fish is located on a long-range setting (about 800 meters) and is approaching own ship do as follows:
- 1) Adjust the tilt to keep the school of fish in the center of the sonar beam, namely, the school of fish is displayed in strongest colors possible.
  - 2) Confirm that the fish echo is displayed in the same color as it approaches.
  - 3) If the color suddenly changes to weaker colors as the fish enters MEDIUM and NEAR areas, the TVG is improperly set. Adjust the TVG.
  - 4) If this setting produces sea surface reflections and noise, try to remove them with the AGC (section 2.7.1) and noise limiter (section 2.9.5).

### **Absorption coefficient**

Attenuation of the acoustic pulse underwater varies with sea area and water temperature. This absorption can be compensated by adjusting the absorption coefficient. In most cases, no adjustment is necessary. If sensitivity decreases with distance, increase the absorption coefficient setting. And if it increases with distance decrease this setting.

## 2.7 How to Adjust Strong and Weak Echoes

### 2.7.1 AGC

The AGC function automatically reduces the receiver gain only against strong echoes such as the bottom or a large school of fish. Since the AGC function does not affect weak echoes, a small school of fish becomes easier to detect. Adjust it so that the AGC works only on bottom reflections. Do not set it too high; weak echoes may be missed.

1. Press the **MENU/ESC** key to show the main menu.
2. Select the [Gain Setting] then push the left-click button.
3. Press the **H/V/S** key to select [H1] or [H2].
4. Select [AGC] then push the left-click button to show the setting box.
5. Select ▲ or ▼ then push the left-click box to change the setting.  
The setting range is -20 to 20. The higher the setting, the higher the degree of suppression.
6. Select [Quit] on the setting box then push the left-click button to close the box.
7. Long-press the **MENU/ESC** key to close all menus.

### 2.7.2 Near AGC

When the water is shallow or heavily sedimented, the unwanted and scattered echoes from close-in may be excessively strong. In this case, a school of fish which is displayed at between 300 and 500 m may disappear gradually when the ship starts approaching the school of fish.

Use the Near AGC feature to suppress this strong echo. Normally set it between 3 and 4, however, this setting depends on the sea condition. Do not set it too high; all echoes (including noise) from near distance may be painted in red.

1. Press the **MENU/ESC** key to show the main menu.
2. Select the [Gain Setting] then push the left-click button.
3. Press the **H/V/S** key to select [H1] or [H2] tab.
4. Select [Near AGC] then push the left-click button to show the setting box.
5. Select ▲ or ▼ then push the left-click button to change the setting.  
The setting range is -20 to 20. The higher the setting, the stronger the echo level on near range.
6. Select [Quit] on the setting box then push the left-click button to close the box.
7. Long-press the **MENU/ESC** key to close all menus.

Near AGC		Quit
Near AGC	: 0	
Near AGC Distance	: 100m	

**Note:** The range which Near AGC covers is set at [Near AGC Distance] in the [Near AGC] menu. The setting range is 20 to 2000 m (20 m step). The setting range can be changed. For details, contact your dealer.



### 2.7.3 2nd AGC

While it is ideal to suppress bottom echoes with the AGC alone there are some fishing grounds where this is not possible. (The high power sonar has the advantage of long-range detection but this can also be a disadvantage, since weaker echoes may be hidden in strong, unwanted echoes such as the bottom.) If you cannot suppress bottom echoes or sea surface reflections by the AGC function alone, use the 2ND AGC feature. Normally a setting of 1 or 2 is suitable. For especially strong echoes, use a setting of 3 or 4.

1. Press the **MENU/ESC** key to show the main menu.
2. Select [Gain Setting] then push the left-click box.
3. Press the **H/V/S** key to select the [H1] or [H2] tab.
4. Select [2nd AGC] then push left-click button.
5. Select [2nd AGC] again then push the left-click button.

2nd AGC		Quit
2nd AGC	: 14	
Distance	: 20m	
Type	: Normal	
Post2nd AGC-Near	: 5	
Post2nd AGC-Far	: 5	
Post2nd AGC Dist	: 100m	
Exclusive Rng S	: ±20°	

6. Select ▲ or ▼ then push the left-click button to change the setting.  
The setting range is 0 to 20. The higher the setting, the stronger the suppression on long range.
7. Select [Quit] on the setting box then push the left-click button to close the box.
8. Long-press the **MENU/ESC** key to close all menus.

#### Other AGC-related items on the [2ND AGC] menu

**Distance:** Set the start range for the 2nd AGC. The setting range is 0 - 2000 m, in 20 m increments. 2nd AGC is inoperative if the display range is lower than the 2nd AGC start range.

**Type:** Select the TVG type for 2nd AGC. Select [Normal] for everyday use.

**Post 2nd AGC-Near\*:** Set the near range threshold for [Post 2nd AGC]. The larger the figure, the greater the suppression.

**Post 2nd AGC-Far\*:** Set the far range threshold for [Post 2nd AGC]. The larger the figure, the greater the suppression.

**Post 2nd AGC-Dist\*:** Switch between Far and Near Post 2nd AGC.

## 2. HORIZONTAL MODE

**Exclusive Rng S:** This feature prevents use of the 2nd AGC, Post 2nd AGC in a certain area at the stern, where unwanted echoes (such as screw noise) can interfere with the 2ND AGC or Post 2nd AGC feature. Set the area of exclusion on the setting dialog box. In the example at right the area of exclusion is  $\pm 45^\circ$ .

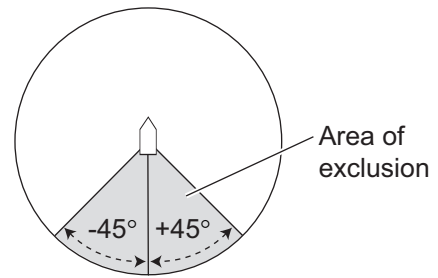

\*The [Post 2nd AGC] functions independently of [2nd AGC]. If the [2nd AGC] cannot suppress the bottom echo or sea surface reflections, try to suppress them with the [Post 2nd AGC]. For particularly strong echoes raise the AGC setting.

### 2.7.4 How to shorten pulse length

The pulse length determines the length of the transmission pulse emitted into the water. While a longer pulse is advantageous for long-range sounding, it has the disadvantage of being poor in discrimination of targets, that is, the ability to separate several closely located targets. When searching bottom fish, therefore, it is useful to shorten the pulse length in order to separate fish echoes from bottom reflections.

**Note:** When searching for surface or midwater fish in which bottom reflections are not so strong, use the longest pulse length "9".

1. Press the **MENU/ESC** key to show the main menu.
2. Select [TX/RX Setting] then push the left-click button.
3. Press the **H/V/S** key to select [H1] or [H2] tab.
4. Select [TX Pulse Length] then push the left-click button.
5. Select **▲** or **▼** then push the left-click button to change the setting. The setting range is 0-9. The higher the setting, the longer the pulse length.
6. Select [Quit] on the setting box then push the left-click button to close the box.
7. Long-press the **MENU/ESC** key to close all menus.

TX/RX Setting			Quit
H1	H2	S	V
TX Interval		: 9	
TX Pulse Length		: 9	
TX Power		: 9	
Frequency...			
Sidelobe Sup....			
Reverberation		: 0	
Beam Width...			

## 2.8 How to Suppress Bottom and Sea Surface Reflections in Shallow Waters

In shallow fishing grounds with hard or rocky bottom, bottom reflections often interfere with wanted fish echoes and they can not be eliminated sufficiently with the aforementioned TVG and AGC functions, especially when the Tilt is set to a larger angle in order to track schools of fish approaching within 400 m. In such cases try to reduce the output power by adjusting the Tx power instead of turning down the gain. The picture becomes clearer when the output power is reduced rather than when the GAIN is decreased as illustrated below.

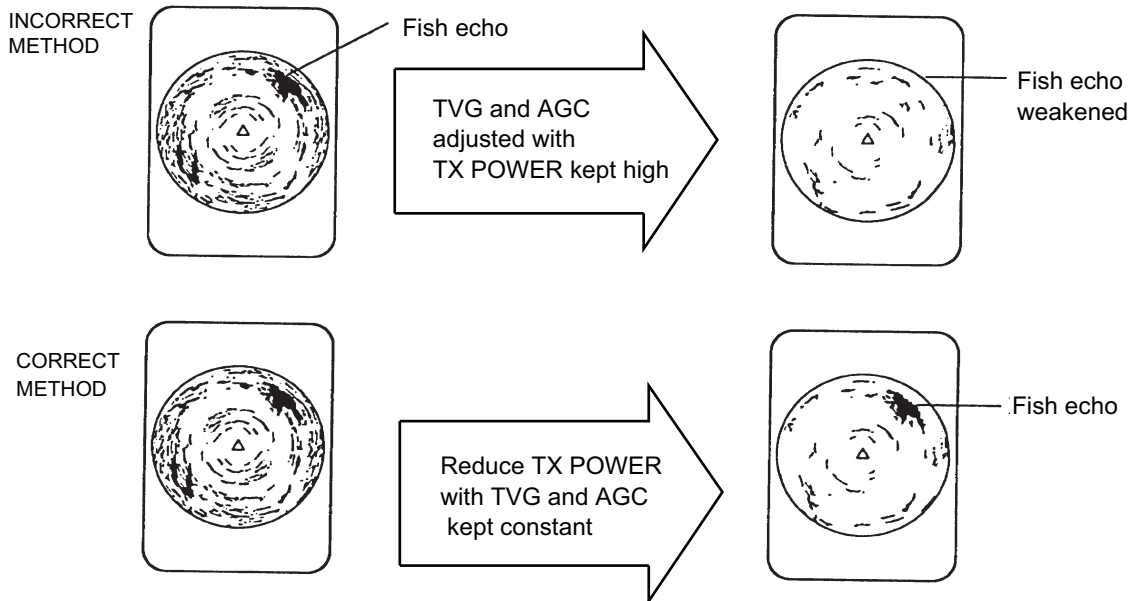

1. Press the **MENU/ESC** key to show the main menu.
2. Select [TX/RX Setting] then push the left-click button.
3. Press the **H/V/S** key to select [H1] or [H2] tab.
4. Select [TX Power] then push the left-click button.
5. Select ▲ or ▼ then push the left-click button to change the setting. The setting range is 0-9. The higher the setting the greater the TX power.
6. Select [Quit] on the setting box then push the left-click button to close the box.
7. Long-press the **MENU/ESC** key to close all menus.

## 2.9 How to Reject Sonar Interference and Noise

While observing the sonar picture, you may encounter occasional or intermittent noise and interference. These are mostly caused by on-board electronic equipment, engine or propeller noise, or electrical noise from other sonars being operated nearby.

### 2.9.1 How to identify the noise source

To eliminate noise effectively, you should first identify the noise source as follows:

1. Press the **MENU/ESC** key to show the main menu.
2. Left-click [Others], then left-click [Initial Settings]. Left-click [Changeable] in the pop-up window.
3. Left-click [Test].
4. Stop transmission on the [Test] menu; turn on [TX]. Turn on the power of all on-board equipment one by one while observing the picture. If noise appears on the sonar display, that equipment is emitting noise. Check the offending equipment's ground and installation.
5. Run the boat at various speeds to check if the noise is speed dependent.

If neither of the above two steps has effect on the picture, adjust one of the following:

### 2.9.2 Change TX interval

When other sonars nearby are operating the same transmission interval as that of own ship's sonar, rings of interference appears on the display.

To remove the rings from the screen, do the following:

1. Press the **MENU/ESC** key to show the main menu.
2. Select [TX/RX Setting] then push the left-click button.
3. Press the **H/V/S** key to select [H1] or [H2] tab.
4. Select [TX Interval] then left-click.
5. Select ▲ or ▼ then push the left-click button to change the setting. The setting range is 0-9. The higher the setting, the longer the TX interval. [EXT KP] is for external KP synchronization; however, adjustment on the System menu is required. See the installation manual.
6. Select [Quit] on the setting box then push the left-click button to close the box.
7. Long-press the **MENU/ESC** key to close all menus.

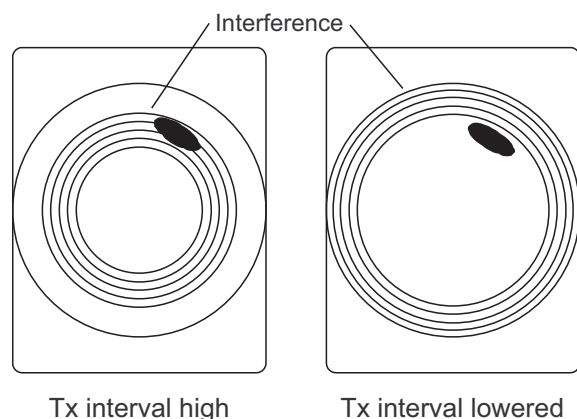

**Note:** When you operate the sonar with the following settings in shallow water, the sea clutter from the previous transmission may appear in near range. To suppress this clutter, reduce the [TX Interval] by 2 or 3.

- Range: 60 to 200 m
- TX Pulse setting: 9

### 2.9.3 Interference rejector

This control is similar to the interference rejector on echo sounders and radars. It is effective for rejecting random noise and sea surface reflections in rough sea conditions. Set it so that noise is just eliminated. Do not use an unnecessarily high setting since it may also reject small, wanted echoes.

1. Press the **MENU/ESC** key to show the main menu.
2. Select [Picture Setting] then push the left-click button.
3. Press the **H/V/S** key to select the [H1] or [H2] tab.
4. Select [Int Reject] then push the left-click button.
5. Select ▲ or ▼ then push the left-click button to change the setting. The setting range is [0] to [3]. The degree of rejection, in ascending strength, is [2], [1], [3]. [0] disables the interference rejector.
6. Select [Quit] on the setting box then push the left-click button to close the box.
7. Long-press the **MENU/ESC** key to close all menus.

Picture Setting		Quit	
H1	H2	S	V
Echo Average	:	2	
Int Reject	:	0	
Smooth Echo RNG	:	3	
Smooth Echo CIR	:	1	
A-Train Echo Average	:	2	
A-Train Int Reject	:	0	

### 2.9.4 Shift TX frequency

If the interference cannot be suppressed by the interference rejector or changed in TX interval, shift the TX frequency from the [Frequency] menu.

1. Press the **MENU/ESC** key to show the main menu.
2. Select [TX/RX Setting] then push the left-click button.
3. Press the **H/V/S** key to select the [H1] or [H2] tab.
4. Select [Frequency] then push the left-click button.

Frequency		Quit
Freq Shift1	:	0
Freq Shift2	:	-65
Freq/Bearing Set	:	0°

5. Select [Freq Shift1] then push the left-click button.
6. Select ▲ or ▼ then push the left-click button to change the setting. The setting range is -65 to 65.
7. Select the [Quit] on the setting box then push the left-click button to close the box.
8. Long-press the **MENU/ESC** key to close all menus.

**Note 1:** In some cases the frequency cannot be changed because of operating bandwidth. In this case the frequency setting is grayed.

**Note 2:** The setting for [Freq Shift2] is valid when [Sidelobe Sup. A] (see section 2.9.9.) is set between -3 and -1. Set [Freq Shift1] well apart from [Freq Shift2] to better suppress sidelobes.

## 2.9.5 Noise limiter

Weak, unwanted reflections, colored light-blue or green, are often caused by dirty water, plankton layers, or ship's noise. The noise limiter can reduce the effects of these unwanted reflections. Raising the setting causes unwanted reflections to be displayed in colors of blue to background color.

1. Press the **MENU/ESC** key to show the main menu.
2. Select [Display Setting] then push the left-click button.
3. Press **H/V/S** key to select the [H1] or [H2] tab.

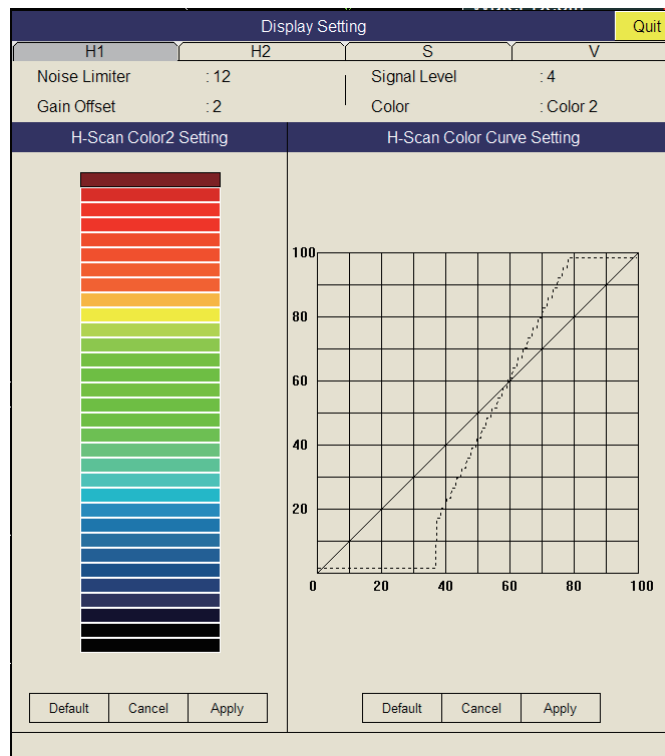

4. Select [Noise Limiter] then push the left-click button.
5. Select ▲ or ▼ then push left-click button to change setting. The setting range is 0 to 15. The higher the setting, the higher the degree of the suppression.
6. Select [Quit] then push the left-click button to close the box.
7. Long-press the **MENU/ESC** key to close all menus.

## 2.9.6 Reverberation

You may select the length of reverberation for the echo signal, with [Reverberation] on the [TX/RX Setting] (H1 or H2 tab). The setting range is 0-3. The larger the value, the lower the reverberation effects. Set the length of reverberation appropriately to make it easier to see the echo signal.

## 2.9.7 Echo average

[Echo Average] ([H1] or [H2] tab) on the [Picture Setting] menu adjusts echo afterglow - the amount of time an echo signal remains on the screen. This feature can be useful for watching echo movement. The setting range is 0 to 11.

**Setting between 1 and 3:** Echoes are gradually displayed and afterglow remains on the screen longer as the setting is increased.

**Setting between 4 and 7:** Echoes are quickly displayed and afterglow remains on the screen longer as the setting is increased.

## 2.9.8 Reference bearing in frequency shift

The reference bearing in frequency shift can be changed to avoid sonar interference and noise. If noise or interference appears at a specific bearing, change the value of the [Freq/Bearing Set] in the [TX/RX Setting] (H1 or H2 tab) - [Frequency] menu. The setting range is 0°-358° and the default setting is 0°.

**Note:** [Freq/Bearing Set] is valid when [Sidelobe Sup. A] (see subsection 2.9.9) is selected to other than 0°.

## 2.9.9 How to suppress sidelobes

False echoes produced by sidelobes may appear on the display depending on the distribution pattern of a school of fish and the positional relationship between it and a marine object (reef, etc.) and wake reverberation. To reduce these sidelobes, use [Sidelobe Suppress] in the [TX/RX Setting] menu (H1 or H2 tab).

Sidelobe Sup.		Quit
Sidelobe Sup.A	: 3	
Sidelobe Sup.B	: 2	
Sidelobe Dir1	: 60°	
Sidelobe Dir2	: 120°	

### Sidelobe suppression A

Watch the echoes while adjusting the suppression. The setting range is -3 to 4 (0 is OFF). The larger the setting, the more the sidelobe is suppressed. For greatest suppression, use a negative setting (-3 to -1).

**Note:** When a negative value is used, [TX/RX Mode] in the [Display Setting] menu is automatically selected to [Alternative]. See "Display Setting Menu" on page 7-3 for details.

### Sidelobe suppression B

For greater sidelobe suppression, use [Sidelobe Sup. B]. The setting range is 1 to 5. The larger the setting value, the more the sidelobe is suppressed; however, the width of the beam increases thus resolution is lower. The negative value setting (-5 to -1) is effective for reducing the effects of screw noise.

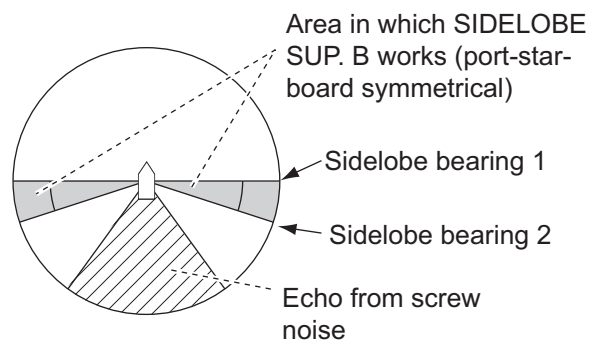

The area in which to suppress sidelobes with [Sidelobe Sup. B] can be set with [Sidelobe Dir1] and [Sidelobe Dir2]. The setting range is  $0^\circ \leq [\text{Sidelobe Dir1}] \leq [\text{Sidelobe Dir2}] \leq 180^\circ$ , symmetrical in port-starboard directions. An area can be set when [Sidelobe Sup. B] is 0 - 5. In this case the settings of Dir1 and Dir2 are gray.

## 2.10 How to Adjust Beam Width

The width of the horizontal beam can be adjusted from the [Beam Width] menu.

1. Press the **MENU/ESC** key to show the main menu.
2. Select [TX/RX Setting] then push the left-click button.
3. Press the **H/V/S** key to select the [H1] or [H2] tab.
4. Select [Beam Width] then push the left-click button.
5. Select the item to adjust then push the left-click button.

Beam Width		Quit
Beam Control	: Manual	
TX Beam Width	: 1	
Hor. RX Beam Wid	: 1	
Ver. RX Beam Wid	: 1	
RX Beam Control	: 0	

### Description of Beam Width menu

**Beam Control:** Control the beamwidth according to option selected. **Manual:** Select this item to enable adjustment of the other items in this menu. **Range:** The beamwidth is automatically controlled with the range setting. **Tilt:** The beamwidth is automatically widened as tilt goes deep. This is convenient for keeping a watch on fish that ascend and descend.

**TX Beam Width\*:** Increase the value to display close-range echoes clearly.

**Hor. RX Beam Width\*:** Increase the value to improve horizontal resolution.

**Ver. RX Beam Width\*:** Increase the value to improve vertical resolution to distinguish fish echoes from bottom echoes.

**RX Beam Control:** Increase the value to improve horizontal resolution.

**Note:** When [RX Beam Control] is set to 1 - 3 and [Sidelobe Sup. B] is set to other than 0, [TX/RX Mode] on the [Display Setting] menu is automatically selected to [Alternative]. See "Display Setting Menu" on page 7-3.

\*: Available only when [Beam Control] is set to [Manual].

6. Select [Quit] on the setting box then push the left-click button to close the box.
7. Long-press the **MENU/ESC** key to close all menus.



## 2.11 How to Track a School of Fish

The target lock function automatically tracks a school of fish so you will not lose sight of it on the display. Two types of target lock are available: position tracking and tracking of school of fish. Select one from the menu as shown in the procedure that follows. The default setting is tracking of school of fish. Speed and bearing data are required. The FSV-85 MARK-2 cannot track a school of fish if the level of the echo is too weak.

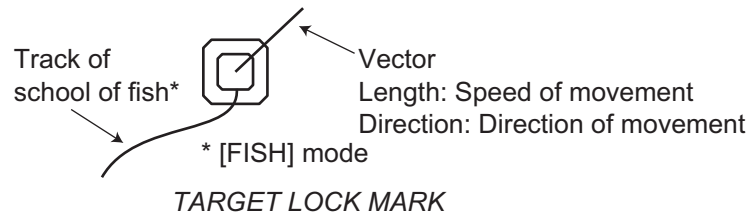

One target lock mark is shown. For the Horizontal 2 and Slant combination displays, the mark is shown on the applicable display. The target lock mark does not appear on the displays where it can not be inscribed.

### 2.11.1 How to select the target lock mode

**Note:** Target lock mode is unavailable when there is a displayed target lock mark.

1. Press the **MENU/ESC** key to show the main menu.
2. Select [Others] then push the left-click button.
3. Select [Initial Setting] then push the left-click button.
4. Select [Changeable] then push the left-click button.
5. Select [Target Lock] then push the left-click button.

Target Lock		Quit
Tracking Method	: Fish	
Tilt Interlock	: Tilt&Range	
Mark Interlock	: Estimate Mark	
Tracking Data	: H & V	
Threshold	: 16	
Bottom Threshold	: 3	
Target Speed Limit	: 5kn	
Smoothing	: 0.5	
Target SPD Update	: 60Sec	
Target Lock Window	: Small	
Dimension Setup	: 25t/1000m <sup>2</sup>	
Volume Setup	: 25t/1000m <sup>3</sup>	

6. Select [Tracking Method] then push the left-click button.
7. Select [Fish] or [Target Mark] then push the left-click button. See subsection 2.11.2 and subsection 2.11.3.
8. Select [Quit] on the setting box then push the left-click button to close the box.
9. Long-press the **MENU/ESC** key to close all menus.

Quit
Cancel
Target Mark
Fish

### 2.11.2 Fish mode

The automatic echo target lock function automatically tracks the operator-selected school of fish. When [TILT INTERLOCK] on the [TARGET LOCK] menu (previous page) is set to [TILT & RANGE], and the tracked school of fish goes out of the zone in the range direction, the range and tilt are automatically changed according to the position of the school of fish.

1. Select [Fish] in the procedure in subsection 2.11.1.
2. On the horizontal display, use the trackball to select the school of fish to track.
3. Press the **TARGET LOCK** key.

The target lock mark (red) is put on the fish school echo. The target lock mark changes to white, with vector, when the school of fish is locked. The vector shows the speed and direction of movement of the school of fish. The tip of the vector is the estimated position of the school of fish when the vector time elapses. The target lock mark also appears on the vertical display, however the vector is not shown.

If the target is lost, the target lock mark changes to red color and the tracking mode changes to position mode (see next section) at that position. When the sonar detects and tracks the target again, the FISH mode is restored.

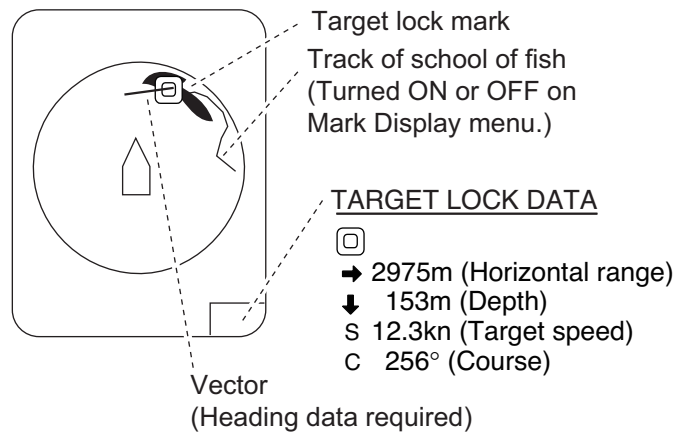

4. To disable the target lock, press the **TARGET LOCK** key.  
**Note:** Target lock may be disengaged if the range control is operated while a locked target is displayed.

### 2.11.3 Target mark mode

This mode tracks a stationary position (such as a reef) using position data fed from a navigator.

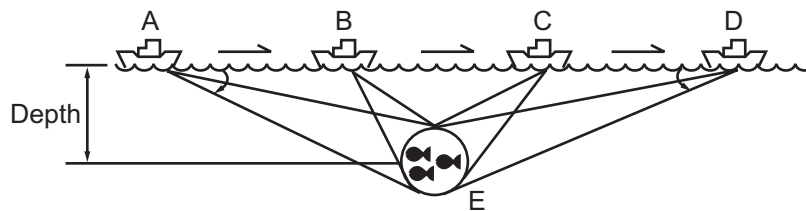

1. Select [Target Mark] in the procedure in subsection 2.11.1.
2. On the horizontal display, use the trackball to select the location to track.

3. Press the **TARGET LOCK** key.  
Tilt, range and vertical bearing are automatically adjusted to track the location. Using the figure above as an example, the target lock mark is placed on location E. Then, the equipment remembers the location of E and automatically changes the tilt angle as the ship moves from position A through D. As long as the school of fish E is stationary its echo is kept displayed on the screen.
4. To disable the target lock, press the **TARGET LOCK** key.

#### 2.11.4 Target lock menu description

Target lock functions not previously mentioned are described below.

**Tilt Interlock:** Provides automatic change of tilt angle and range or tilt angle in target lock. (Setting options: [OFF], [Tilt], [Tilt & Range])

**Mark Interlock:** Turns numeric/graphic data displays ON/OFF in target lock. [Off] turns off both the estimate mark 1, 2 histogram and data display. [Estimate Mark] enables the estimate mark 1, 2 histogram. [Est & Fish Info] enables the both the estimate mark 1, 2 histogram and data display.

**Tracking Data:** Selects which target lock tracking data to use, horizontal or slant, or both horizontal and vertical.

**Threshold:** Selects the minimum signal level to use in target lock tracking. The setting range is 1 to 30. Target lock tracks a target whose signal level is greater than set here.

**Bottom Threshold:** When a target is judged as a bottom echo, raise this setting to differentiate bottom from target. The setting range is 0 to 5.

**Target Speed Limit:** Sets maximum fish speed to track. The setting range is 1kn to 15kn.

**Smoothing:** Sets smoothing rate for fish speed data. The higher the figure, the smoother the position of the target lock target. Avoid oversmoothing, to prevent delay in tracking when own ship or target moves suddenly. The setting range is 0.0 to 1.0.

**Target SPD Update:** Sets the interval at which fish speed data is updated. The intervals are 15, 30, 45 and 60 seconds.

**Target Lock Window:** Selects the size of target lock detection area; normal, large, largest. (The area is not indicated on the screen.)

**Dimension Setup:** Sets dimension constant for calculation of weight (ton) of school of fish from the dimension of the school of fish.

**Volume Setup:** Sets volume constant for calculation of weight (ton) of school of fish volume.

## 2.12 Presentation Mode

### 2.12.1 Presentation mode description

This sonar has four presentation modes, head-up, north-up, course-up and true motion. Select one with [Presentation Mode] in the [Others] - [Display Setting] menu.

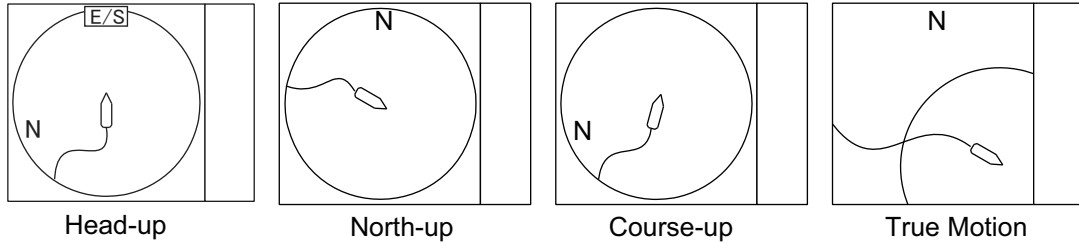

**Head-up:** The display is oriented toward ship's heading. The heading direction appears at the top of the display. Own ship position is fixed at the screen center. Echoes from fish and the bottom move on the screen relative to own ship's movement. This mode is useful for general use.

**North-up:** The display is oriented so North is at the top of the screen. Own ship position is fixed at the screen center and own ship mark pivots with ship's movement. Echoes from fish and the bottom move on the screen relative to own ship's movement.

**Course-up:** The display is oriented according to course. Own ship position is fixed at the screen center. Echoes from fish and the bottom move on the screen relative to own ship's movement. Targets are displayed at ship's bow.

**True Motion:** Stationary objects are fixed and own ship and fish echoes move on the display in accordance with their true courses and speeds. Thus you can observe own ship and fish echo movement with respect to the bottom. This mode requires speed and heading data. When own ship mark reaches an edge of the off-center effective area it is automatically returned to the screen center as below.

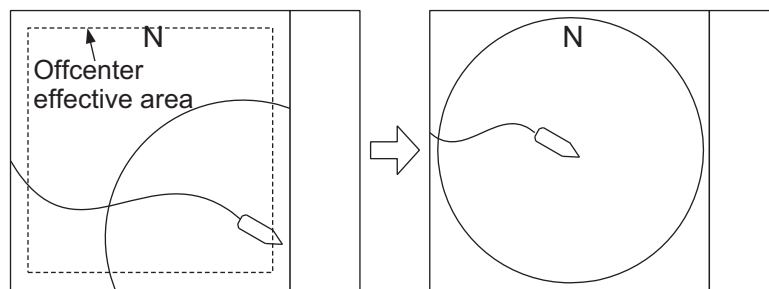

(a) Own ship mark reaches an edge of offcenter effective area

(b) Own ship mark is automatically returned to screen center

*Automatic return of own ship mark in true motion*

### 2.12.2 How to select a presentation mode

1. Press the **MENU/ESC** key to show the main menu.
2. Click [Others].
3. Click [Display Setting].
4. Click [Presentation Mode].
5. Click desired mode.
6. Click [Quit] on the setting box to close the box.
7. Long-press the **MENU/ESC** key to close all menus.

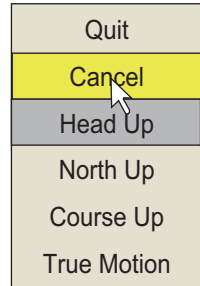

**Note:** The true motion display range may be set to 1.3 to 1.6 times the range with [TM Disp Range] on the [Display Setting] menu.

## 2.13 How to Detect Schools of Fish Aurally

Sometimes you may be preoccupied with other tasks and unable to concentrate on watching the sonar picture. In such cases it would be a good choice to use the audio function. This function enables you to monitor echoes from schools of fish and bottom through the external speaker.

### 2.13.1 How to set the bearing

In the default setting, the audio function is on and the audio sector is 30°.

1. Operate the trackball to place the cursor on the direction you want to monitor through the speaker.
2. Press the **R/B AUDIO** key.

The monitoring section is set on the bearing selected, in a 30°, 60°, 90°, 180° or 330° sector centering the audio bearing mark. Echoes are monitored through the speaker.

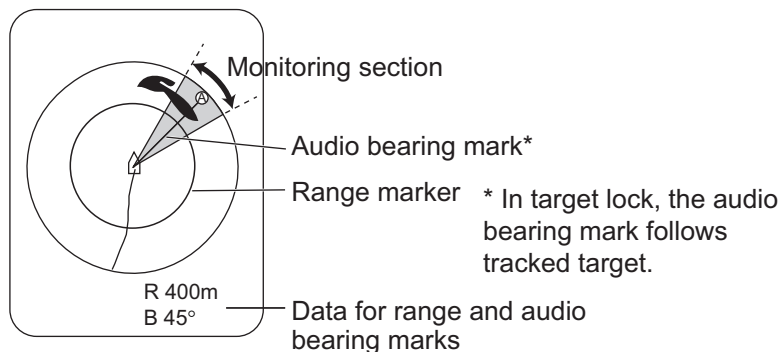

**Note:** To erase the range mark and its data (at the bottom of the screen), put the cursor near own ship mark (transducer position) and press the **R/B AUDIO** key. Note that the audio bearing is erased when [Audio] on the [Alarm & Audio] menu is turned off.

### 2.13.2 How to select the audio sector

Select the audio sector as follows. Note that you cannot see this sector on the display.

1. Press the **MENU/ESC** key to show the main menu.
2. Select [Others] then push the left-click button.
3. Select [Alarm & Audio] then push the left-click button.

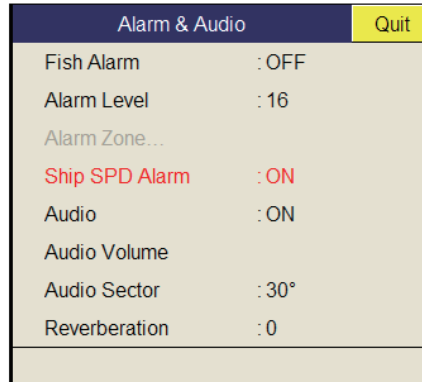

4. Select [Audio Sector] then push the left click button.
5. Select desired sector then push the left-click.
6. Select [Quit] on the setting box then push the left-click button to close the box.
7. Long-press the **MENU/ESC** key to close all menus.

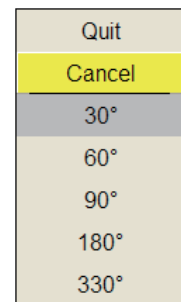

### 2.13.3 Automatic training

You may automatically scan the audio sector and audio bearing mark in the sector of 12°, 24° or 36° as shown below.

1. First activate the range and audio bearing marks with the **R/B AUDIO** key.
2. While pressing and holding down the **AUTO TRAIN** key, press the **R/B AUDIO** key to select desired auto train sector among ±12°, ±24° or ±36°, or OFF to disable automatic training.

Watch the auto train mark to know the currently selected sector. The chosen sector appears in large characters for five seconds at the top of the screen.

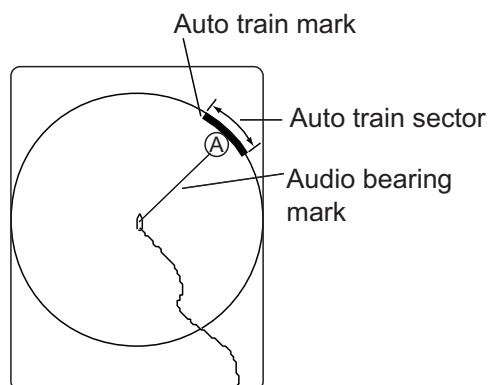

**Note 1:** The automatic training is inoperative when the target lock function is active. Turn off the target lock function to use automatic training.

**Note 2:** Select [Off] at step 2 to stop the training.

### 2.13.4 Reverberation for audio signal

You may select the length of reverberation of the audio signal, with [Reverberation] on the [Alarm & Audio] menu. The larger the value the longer the reverberation, which makes it easier to hear the audio signal. The setting range is 0 to 9 and the default setting is 0.

## 2.14 Fish Alarm

The fish alarm sounds the buzzer when a fish echo above a preset strength enters the operator-set alarm zone.

1. Press the **MENU/ESC** key to show the main menu.
2. Select [Others] then push the left-click button.
3. Select [Alarm & Audio] then push the left-click button.
4. Select [Fish Alarm] then push the left-click button.
5. Select [ON] then push the left-click button.
6. Select [Quit] on the setting box then push the left-click button.
7. Select [Alarm Zone] then push the left-click button.
8. Operate the trackball to place the cursor on the starting point of the alarm zone.
9. Push the left-click button.
10. Operate the trackball to select the ending point. The display paints a fan-shaped alarm zone.

The alarm range appears on the display as shown below.

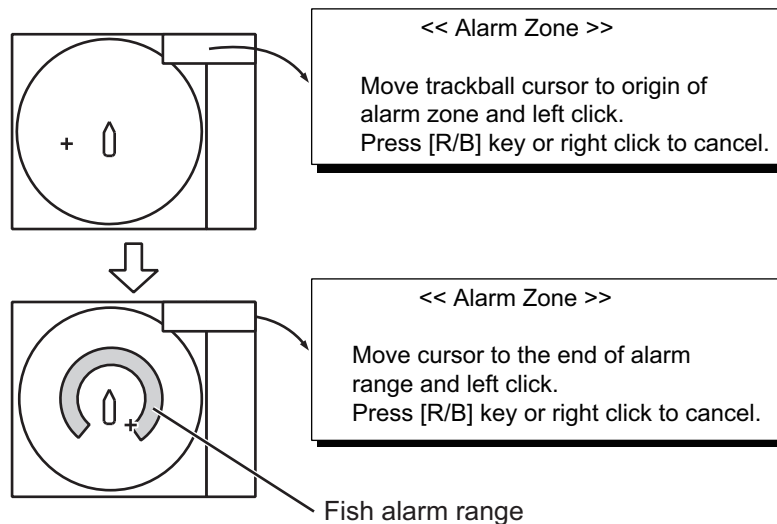

11. Push the left-click button.
12. Long-press the **MENU/ESC** key to close all menus.

When a fish echo enters the alarm area the buzzer sounds.

**Note 1:** There must be at least three degrees difference between the starting and ending points to get a fan-shaped alarm zone as shown in (a) and (b) below. Otherwise, the unit paints a 360-degree alarm zone as in (c) where there is less than 3 degrees between the starting and ending points.

## 2. HORIZONTAL MODE

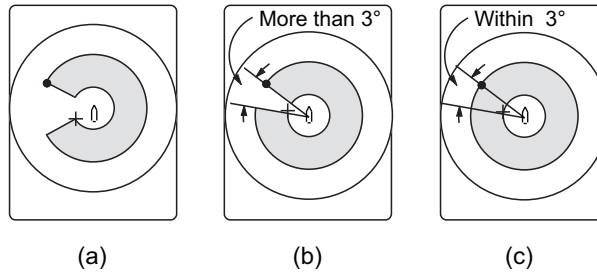

**Note 2:** The echo strength which triggers the alarm can be set with [ALARM LEVEL] on the [Alarm & Audio] menu. The setting range is 0-30. This value corresponds with the 32-echo colors.

To disable the alarm, select [OFF] in the procedure on the previous page.

## 2.15 How to Relocate a School of Fish

The offcenter feature relocates a school of fish.

1. Operate the trackball to place the cursor on the position where you want to relocate the own ship mark.
2. Press the **OFF CENTER** key.
3. To move the own ship mark back to the screen center, press the **OFF CENTER** key again.

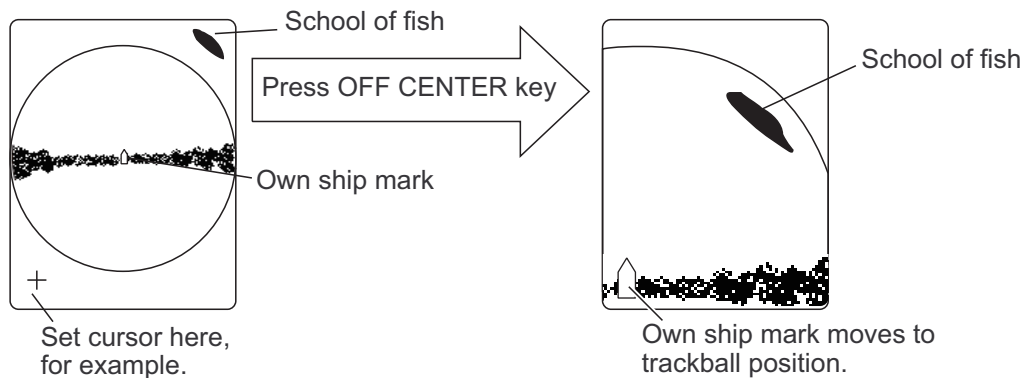

**Note 1:** The offcenter feature cannot be canceled in the true motion mode. Switch the mode to cancel the offcenter. When the **OFF CENTER** key is pressed, the own ship mark moves to the cursor position.

**Note 2:** You can also activate the offcenter feature by Long-pressing the left button with the cursor in the echo display area. To restore the normal display, Long-press the right button.



## 2.16 How to Compare Concentration of School of Fish

### 2.16.1 How to compare with the fish estimate mark

You can get an estimate of the volume of two schools of fish by using the two **ESTIMATE** keys as follows:

1. Operate the trackball to place the cursor on a school of fish, and then press the **ESTIMATE 1** key.  
The estimate mark 1 appears on the school of fish. Relative volume is shown by a figure between 0 and 100, below the estimate mark. When the area inside the mark is filled in reddish brown, volume figure is said to be 100. When the estimate mark is entered, a graph is shown at the histogram on the numeric/graphic data display.
2. Operate the trackball to place the cursor on another school of fish, and then press the **ESTIMATE 2** key.  
Compare estimate figures for each school of fish by observing estimate mark data and the fish histogram.
3. To turn off the estimate marks press their respective keys.

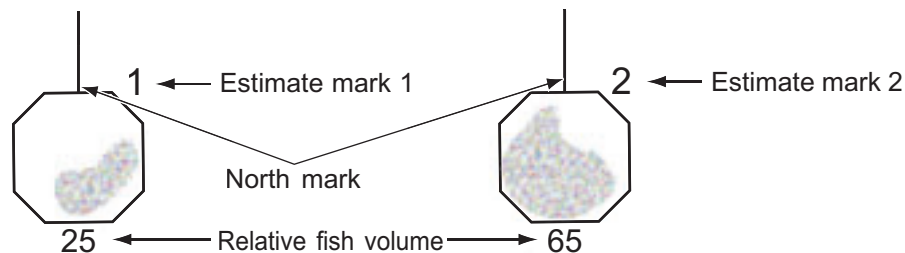

**Note:** The fish school mark and event mark 1 can be entered with the fish estimate mark. For details, contact your dealer.

#### **Fish histogram**

The fish histogram shows, in graph form, signal strength distribution for the school(s) of fish marked with an estimate mark on the horizontal/slant displays. The histogram display for each of those displays will be different since the calculation method is different. This data appears only when an estimate mark is active. When two estimate marks are active, histograms are displayed one on top of the other as below.

The horizontal axis shows signal strength in 16 colors, and the vertical axis shows the concentration of a school of fish inside the fish estimate mark. For the fish estimate mark inscribed on the horizontal display (or slant display) the graph shows the average movement in five scans, to increase accuracy.

## 2. HORIZONTAL MODE

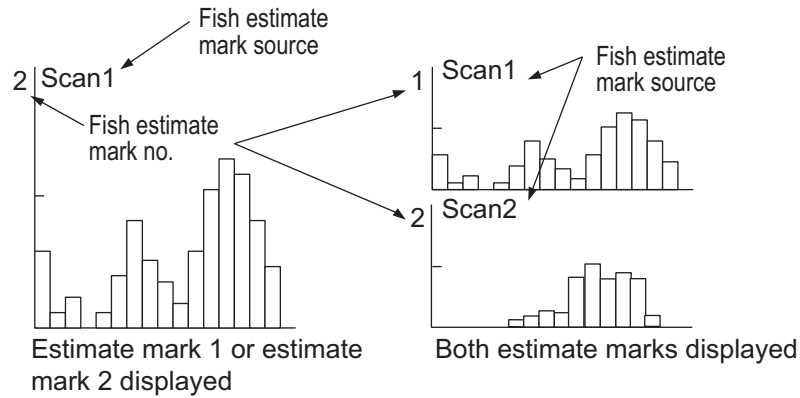

**Note:** The histogram display is redrawn five transmissions after a fish estimate mark is erased and another mark of the same number is entered soon after.

### 2.16.2 How to compare with the circle cursor

You can get an estimate of the volume of two schools of fish with the circle cursor as follows:

1. Push the scrollwheel to show the circle cursor.  
The cross cursor changes to the circle cursor (dotted line).

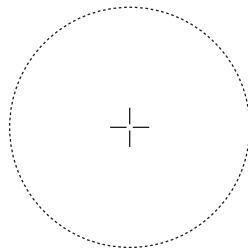

83 m ← Diameter of the circle cursor

2. Place the circle cursor on a school of fish.
3. Rotate the scrollwheel to adjust the size of the circle cursor.  
Set the school of fish in the circle cursor to estimate correctly. The diameter of the circle cursor is displayed below the circle cursor.  
**Note:** The last digit is rounded of when the diameter is greater than 100 m.
4. Place the circle cursor on another school of fish to estimate the volume.  
You can compare the volume of two schools of fish with the diameter of the school of fish.
5. Right click to quit the measurement.  
The circle cursor is changed to the normal cursor.

**Note:** Set the diameter of the circle cursor at [Circle Cursor Diameter] in the [Display Setting] menu (default: 200 m). See section 7.3.

## 2.17 How to Measure the Speed of a School of Fish

To ensure a good haul, it is important to estimate the direction and speed of the school of fish before shooting the net. You can do this with the **FISH** key. With tidal current data and fish speed data, you can determine the timing of the net shooting more efficiently. Fish mark has a two types (□ fish mark 1/◇ fish mark 2) and a maximum of 20 fish marks can be entered per mark type. This function requires speed and heading data.

### 2.17.1 How to measure the speed of a school of fish

1. Place the cursor on the center of a school of fish then press the **FISH** key or push the left button. The latest fish mark (□ or ◇) appears on the school of fish.
2. Wait until the target fish moves a reasonable distance from the latest fish mark.
3. Place the cursor on the same school of fish selected in step 1 then press the **FISH** key.

The latest fish mark (□ or ◇) appears on the target, the 2nd latest fish mark (□ or ◇) appears on the location selected at step 1 and any earlier fish marks are shown with an X. The distance between the two fish marks and speed, course, and bearing of the school of fish appear at the bottom right-hand corner of the horizontal display area.

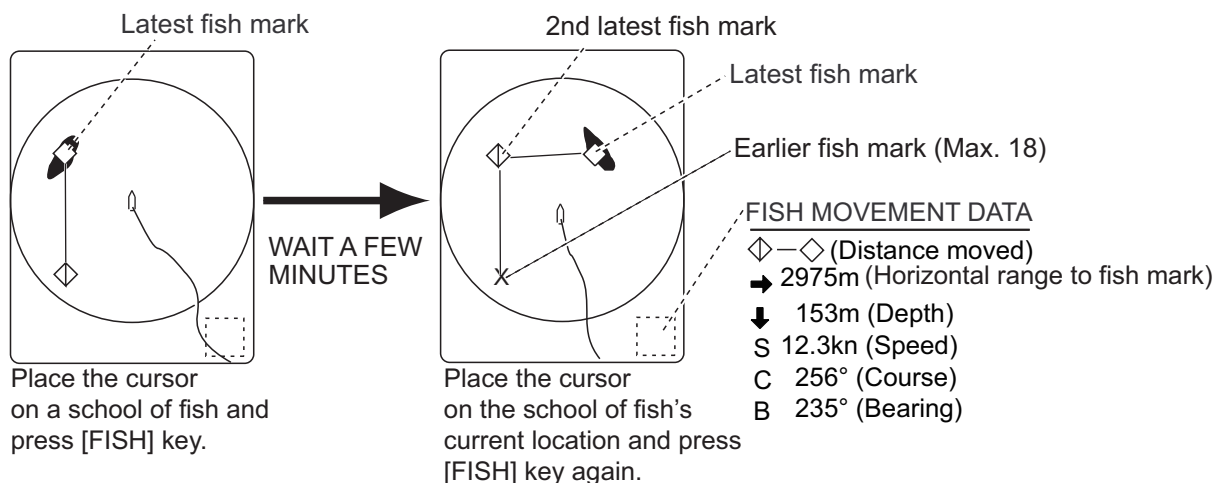

**Note 1:** The time and distance between each press of the **FISH** key should be as long as possible to increase accuracy of measurement. For best results, repeat the procedure two or three times.

**Note 2:** In the default arrangement, a mark can be entered by left clicking in the display area.

**Note 3:** Each time the **FISH** key is pressed the latest fish mark and ship's speed mark change in the sequence shown below. A maximum of 20 fish marks can be entered. When you enter more than 20, the earliest fish mark is erased.

**Fish Mark 1**

[FISH] key pressed once  
 // // twice  
 // // three times  
 // // four times

This data is the latest fish mark data.

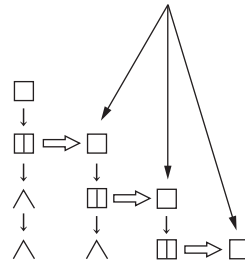

**Fish Mark 2**

[FISH] key pressed once  
 // // twice  
 // // three times  
 // // four times

This data is the latest fish mark data.

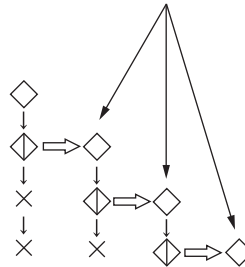

**2.17.2 How to delete fish marks**

Fish marks can be deleted individually with the **DELETE MARK** key or by earliest entry from the menu.

**How to delete fish marks with the DELETE MARK key**

Use the trackball to place the cursor on the fish mark you want to erase. The color of the fish mark changes from white to red when the fish mark is correctly selected. Press the **DELETE MARK** key to delete the fish mark.

**How to delete fish marks from the menu**

1. Push the right button on the numeric/graphic data display to show the pop-up menu.
2. Click [Erase Marks].

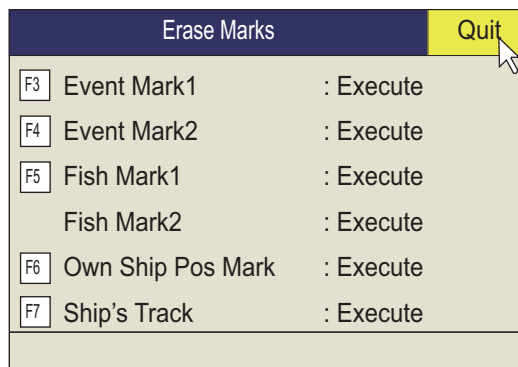

3. Click [Fish Mark1] or [Fish Mark2]. Each click deletes the earliest fish mark.
4. Long-press the **MENU/ESC** key to close all menus.

**Note:** The default function of the **5/F5** key (for fish mark 1) deletes the earliest fish mark.

## 2.18 Event Mark, Own Ship Position Mark

The event mark is useful for finding the horizontal range, depth and bearing to a location some distance from current position. 20 such marks may be inscribed on the horizontal display. This function requires speed and heading data.

There are two types of event marks, latest event mark 1 and event mark 2. Each time an event mark is entered the latest event mark appears at the cursor position and all other event marks are shown by marks and numbered in sequential order. When the memory capacity for event marks is reached the earliest event mark is automatically erased to make room for the latest.

### 2.18.1 How to enter an event mark

1. Set the cursor where you want to enter an event mark.
2. Press an **EVENT** key. The horizontal range, depth and bearing to the event mark appear at the bottom left corner of the horizontal display area. The event mark 1 can also be entered by pushing the right button.

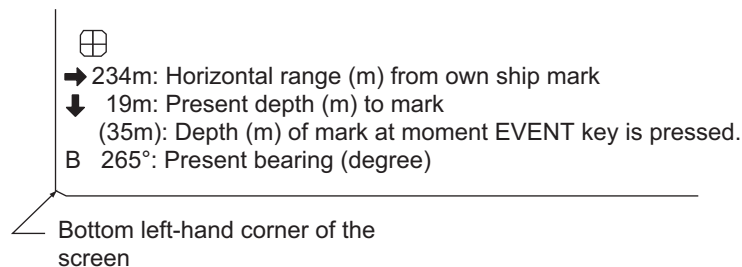

*Ex. Indications when the **EVENT** ⊕ key is pressed*

With speed and heading data the mark follows own ship's movements. In the True Motion mode, the event mark is stationary. When the tilt angle is changed, the present depth to event mark changes. Note however that the mark's position does not change when automatic tilt is active; the tilt center angle is used to position the mark.

Plotting an event mark on the display is equivalent to dropping a buoy with an anchoring chain that extends from surface to bottom. The buoy is fixed at its geographical location, but the marker on the display moves to a point where the present beam plane intersects the anchor chain of the buoy as the ship moves or the tilt angle is changed. This can be said about marks as well such as fish mark and cursor.

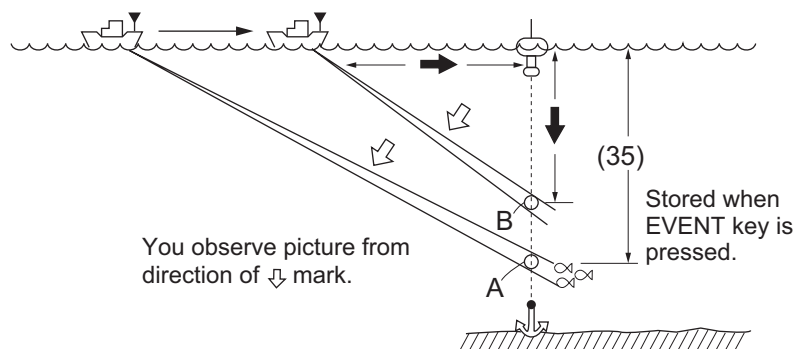

### 2.18.2 How to enter an own ship position mark

Place the cursor close to the center of the own ship mark (transducer position) and press the **EVENT** key. Ten own ship position marks may be inscribed. When the capacity for own ship position marks is reached the earliest own ship position mark is automatically erased.

**Note:** The **SHOOT** key can enter the own ship position mark. Set [Event Key] to [Shoot] on the [Mark Display] menu.

### 2.18.3 How to erase an event mark, own ship position mark

Event marks and own ship position marks can be deleted individually with the **DELETE MARK** key or by earliest entry from the menu.

#### Delete an event mark, own ship position mark with MARK DELETE key

Use the trackball to place the cursor on the event mark or own ship position mark you want to erase. The color of the mark changes from white to red when the mark is correctly selected. Press the **DELETE MARK** key to delete the mark.

#### Delete an event mark, own ship position mark from the menu

1. Push the right-click button on the numeric/graphic data display to show the pop-up menu.
2. Select [Erase Marks] then push the left-click button.
3. Select [Event Mark1], [Event Mark2] or [Own Ship Pos Mark] then push the left-click button.  
Each push of the left-click button deletes the oldest event mark or own ship mark.
4. Long-press the **MENU/ESC** key to close all menus.

**Note:** The default function of the **3/F3** (for event mark 1), **4/F4** (for event mark 2) and **6/F6** (own ship position) keys delete the oldest event mark or own ship mark.

## 2.19 Select Mark Window

From the [Select Mark] window, you can enter event mark 1, event mark 2, fish mark, target lock mark, fish abundance mark 1, and fish abundance mark 2. Additionally, you can switch between the cross cursor and the circle cursor.

To open the [Select Mark] window, Long-press the scrollwheel. To enter a mark, left or right click a mark on the window, then left click where you want to enter a mark. For the circle cursor, left or right click the circle cursor on the window, and the cross cursor changes to the circle cursor (dashed line).

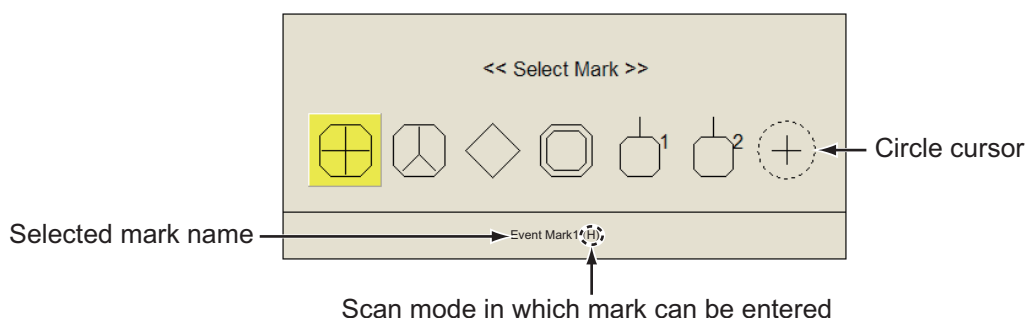

## 2.20 Net Course Mark

Before shooting the net, decide the shoot timing considering tide direction, distance to the school of fish and moving direction of the school of fish. Use the net course mark as a guide to decide the timing. This function requires speed and heading data.

### How to enter the net course mark

1. Press the **MENU/ESC** key to show the main menu.
2. Click [Others].
3. Click the [Display Setting].
4. Click the [Net Course Mark].

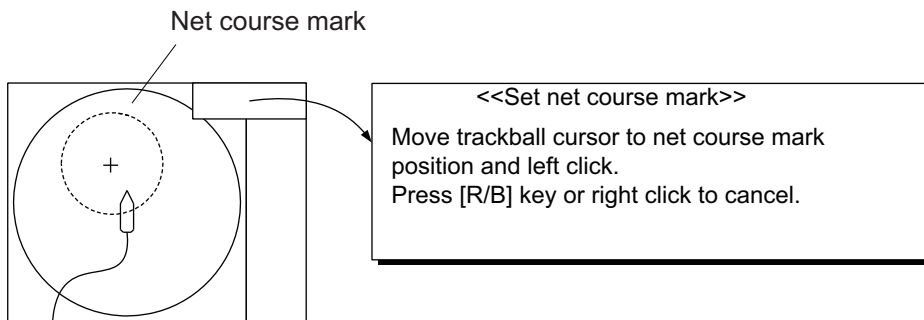

5. Use the trackball to position the net course mark, which is shown by a dashed circle.
6. Push the left button to set, and the dashed circle changes to a solid one.
7. Long-press the **MENU/ESC** key to close all menus.

**Note 1:** To delete the net course mark select [Delete] at step 4.

**Note 2:** The default function of the **0/F10** key deletes the oldest net course mark.

## 2.21 Net Behavior

With connection of a net sonde, you can observe net behavior after the throwing of the net. Accurate depiction of net sonde position depends on proper setting of the distances between net sonde transmitters. You can set those distances on the main menu-[Others] - [Initial Setting] - (Change confirmation window) - [Net Sonde Setting] menu. This function requires speed and heading data.

**Note:** To enable this feature, set [Event Key] to [Event] in the [Mark Display] menu, then do the following:

1. Press the **SHOOT** key just upon throwing the net into the water. The following actions occur:
  - Net shoot mark appears at own ship position.
  - Net shoot data appears at top of the display.
  - Net sonde mark is inscribed.
  - Net depth data is displayed.
  
2. To erase the net sonde mark and associated data, press the **SHOOT** key again.

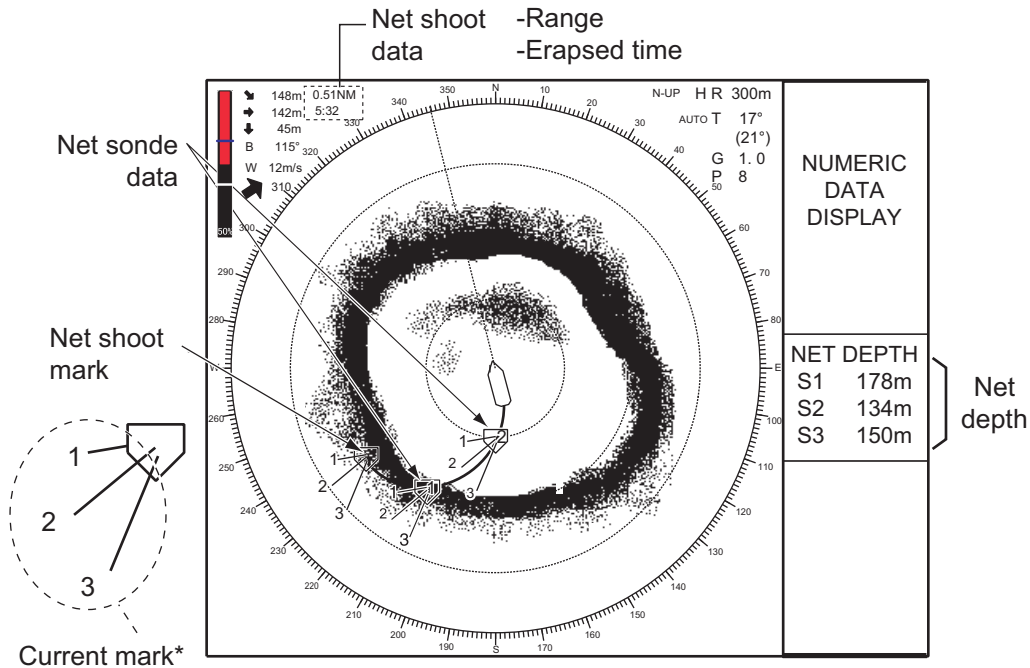

**Note:** To turn the current mark on/off, see page 7-13.



## 2.22 Menu Items Descriptions

This section presents an overview of the horizontal display related menus not previously described.

### Gain Setting menu

Gain Setting			Quit
H1	H2	S	V
TVG-Near		:5	
TVG-Medium		:5	
TVG-Far		:2	
TVG Distance...			
Sel. TVG Curve		:TVG 3	
AGC		:0	
Near AGC...			
2nd AGC...			
Absorption Coeff.		:26.5dB	
Gain Control		:Wide	

**Gain Control:** If the amount of gain change affected with the **GAIN** control on the front panel is too low, change the setting to [Wide], to double the range of the control.

### Display Setting menu

Display Setting				Quit
H1	H2	S	V	
Noise Limiter	:6	Color		:Color 2
Gain Offset	:1	Color Response		:Color Curve 1
Signal Level	:4			

**Gain Offset:** Adjusts gain level. If the **GAIN** control on the front panel does not provide satisfactory gain adjustment, enter an offset here. The setting range is 0 to 12.

**Signal Level:** Contaminated water or reflections from plankton may be painted on the screen in green or light-blue. These echoes may be erased in order of strength. The setting range is 0 to 15; 0 corresponds to the weakest color.

**Color:** Selects color arrangement to use. The default setting is Color 1 to 4.

**H-Scan Color1 (or 2 to 4) Setting:** Customizes colors. See the procedure on the next page.

## 2. HORIZONTAL MODE

1. Operate the trackball to select color then push the left-click button to show the color bar.

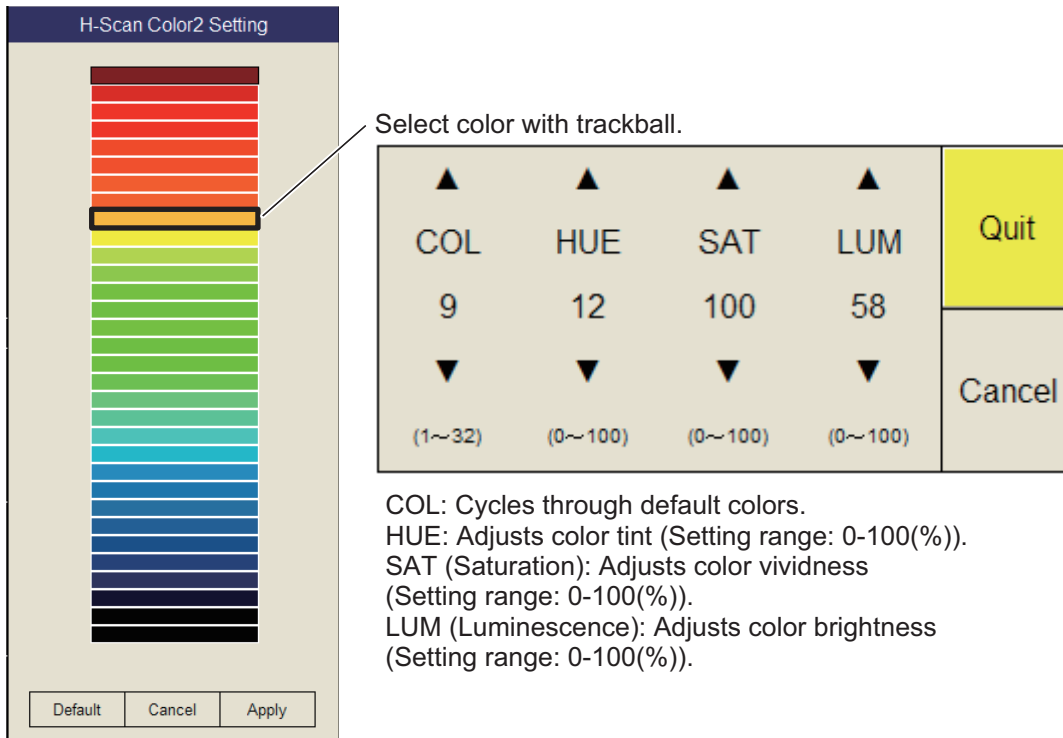

2. Select ▲ or ▼ for COL, HUE, SAT or LUM.
3. Push the left-click button several times to set.
4. Repeat steps 2 and 3 to complete other items.
5. Select [Quit] then push the left-click button.
6. Repeat steps 1 through 5 to set other colors.
7. Select [Apply] then push the left-click button.

**Note:** To restore default color setting, select [Default] on the window push the left-click button then click the [Apply] button.

**H-Scan Color Curve Setting:** Adjusts reflected echo strength versus echo color level for currently selected color response number. To adjust the curve, place the trackball at the point desired then push the left-click button. On the horizontal axis input level relative value is shown in the range from 0 to 100%. The setting range for input level is 0-100% in increments of 10% and output level is 0-100% in any value. Select [Apply] then push the left-click button.

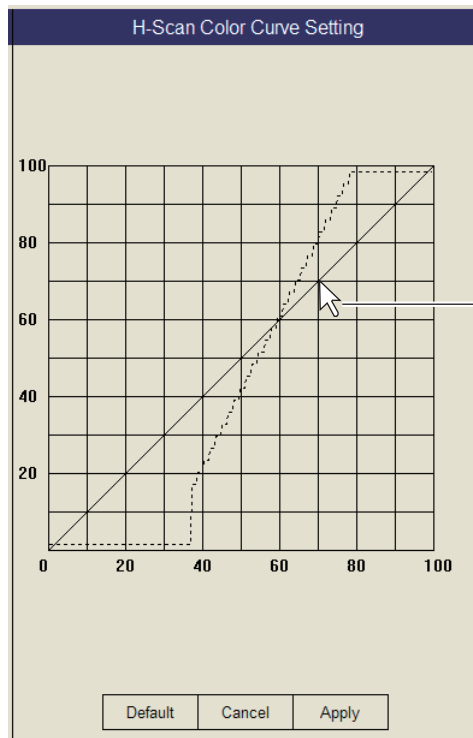

To set input level versus output level, use the trackball to place the cursor on location desired and push the left-click button.

**Note:** To restore default color setting, select [Default] on the window push the left-click button then click the [Apply] button.

### Picture Setting menu

Picture Setting		Quit
H1	H2	V
Echo Average	:	1
Int Reject	:	2
Smooth Echo RNG	:	3
Smooth Echo CIR	:	0

**Smooth Echo RNG:** Selects echo smoothing level in the range direction. The setting range is 0 to 7. The higher the setting, the greater the smoothing.

**Smooth Echo CIR:** Selects echo smoothing level in the circular direction. The setting range is 0 to 5. The higher the setting, the greater the smoothing.

## 2.23 How to Interpret the Horizontal Display

### 2.23.1 Bottom and school of fish echoes

#### Bottom echoes

When the tilt angle is changed, the bottom echo illustrated below will appear on the display. When the tilt is decreased (toward 0°), the bottom trace becomes wider and weaker. By observing the bottom condition on the display, the skipper can prevent net damage.

(A) Flat bottom

Tilt angle: 10° to 15°

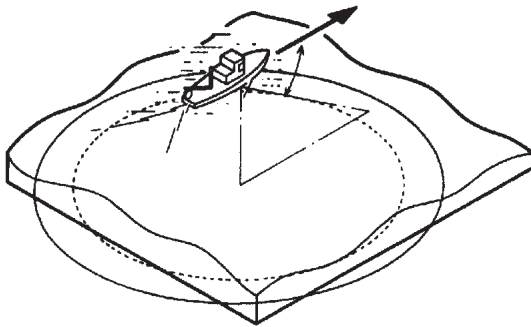

Bottom echo

The bottom echo is captured by the entire beam. The bottom echo in the foreground is strong; weak on the periphery.

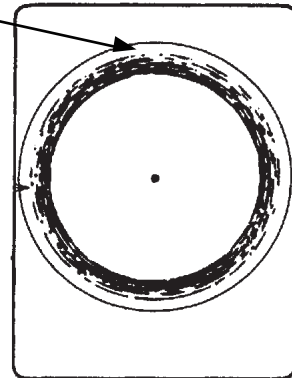

(B) Flat bottom

Tilt angle: 20° or more

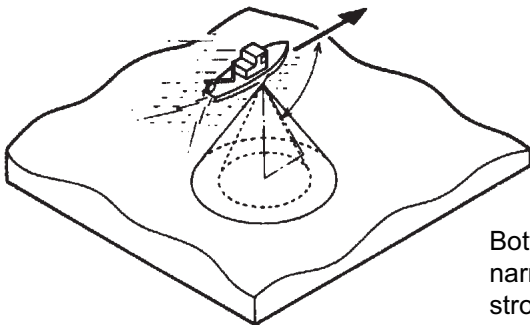

Bottom is displayed narrower and in stronger colors when compared to (A).

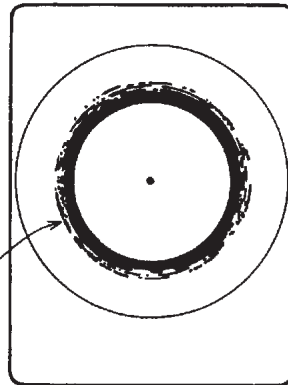

(C) Sloping bottom

Tilt angle: 20° or more

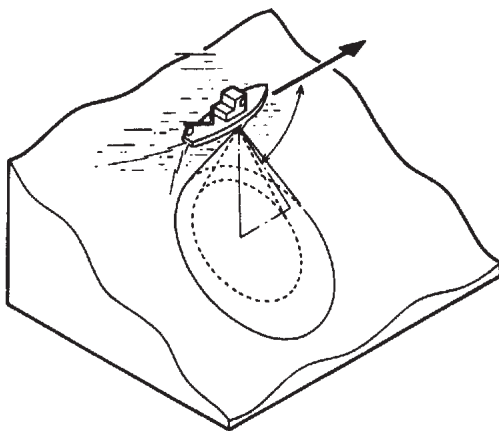

Shallow bottom is displayed in a strong color and with a short tail

Bottom

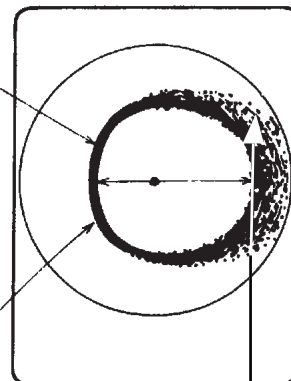

The deeper, sloping bottom echo is displayed in a weak color and with a long tail.

**School of fish**

A school of fish appear as a mass of echoes on the screen. By this display pattern, the density of the school on the sonar beam can be found. To find distribution and center point of a school of fish, try several different tilt angles.

(A) Sea surface fish  
Tilt angle: 0° to 10°

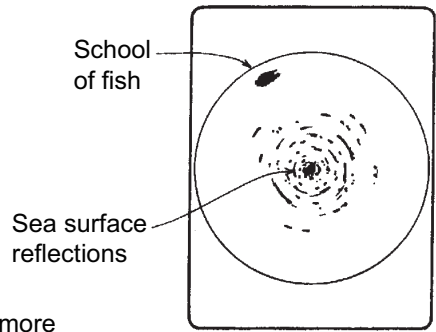
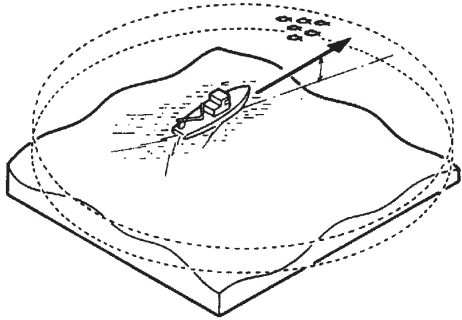

Bottom echo not displayed because of decreased tilt angle. Sea surface reflections are present.

(B) Midwater, bottom fish Tilt angle: 30° or more  
Fish echo which appears before bottom can be detected.

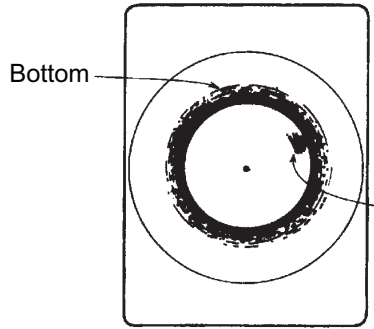
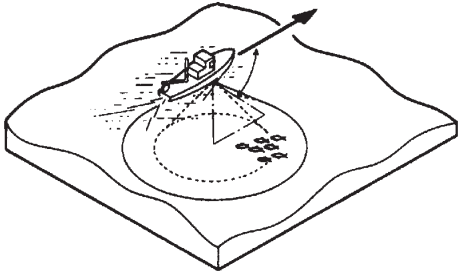

School of fish  
Bottom echo clearly displayed.

Tilt angle: 0° to 20°  
Fish echo which appears together with or after bottom can be detected.

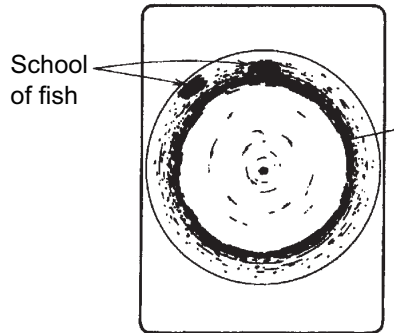
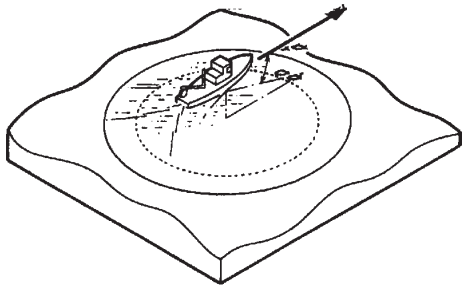

When the tilt angle is shallow, the reflection echo from bottom is weak and the fish echo that appears from bottom is easy to find.

### 2.23.2 Unnecessary echoes

#### Sea surface reflections

To reduce sea surface reflections, set the tilt angle to 4° or higher, so the upper edge of the sonar beam does not hit the sea surface, or adjust near gain. When a decreased tilt is used, sea surface reflections cover a large area as illustrated below.

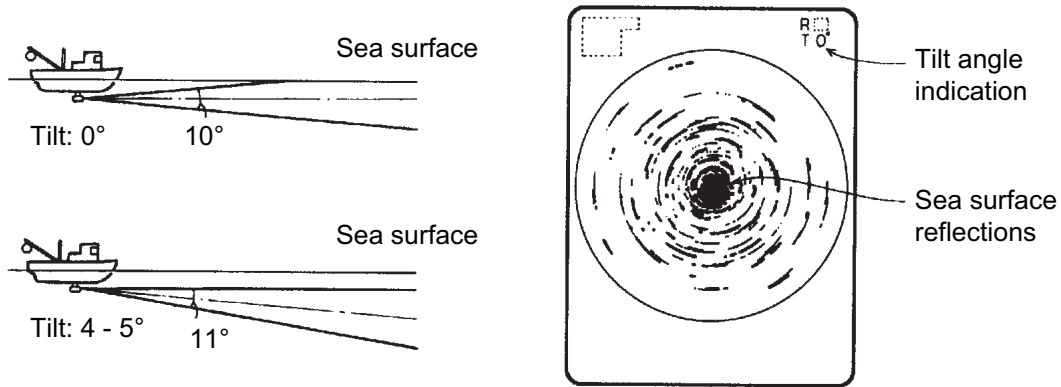

#### Wake

A wake produced by own ship or another ship can be a strong reflecting object when a decreased tilt angle is used. As the wake appears as a thick continuous line, it can be easily distinguished from a school of fish. A wake contains many air bubbles which attenuate ultrasonic energy, making it difficult to sound beyond the wake.

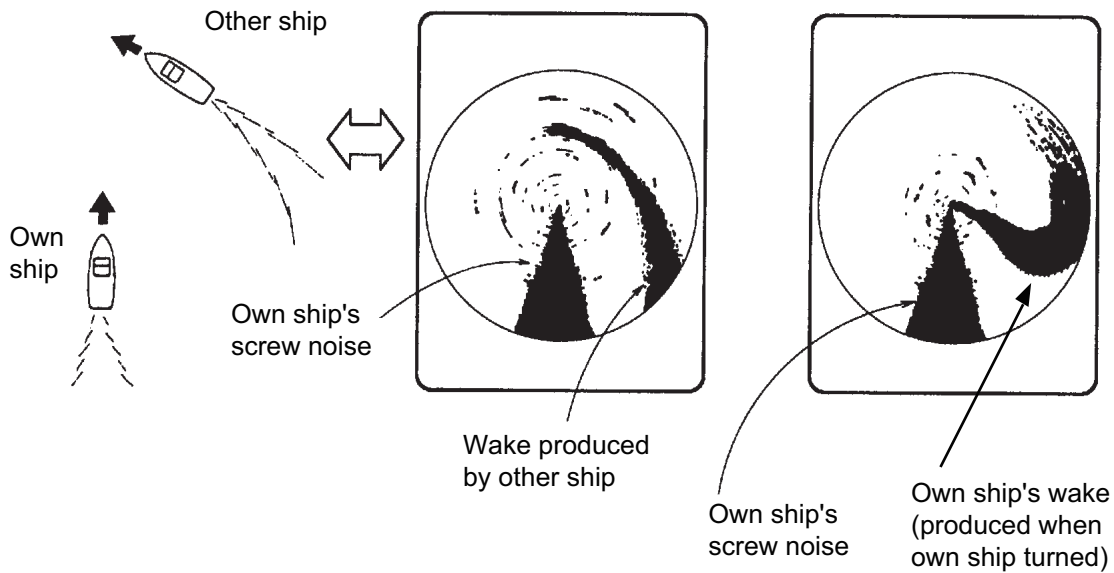

**Sidelobe echoes (false echoes)**

An ultrasonic wave is emitted only in the direction set by the **TILT** control, however there are some emissions outside the main beam. These are called sidelobes. The energy of the sidelobe is fairly weak but when the water is comparatively shallow and the bottom is rocky and hard, strong signals are detected by the sidelobe. These are represented on the display as a false echo as shown below.

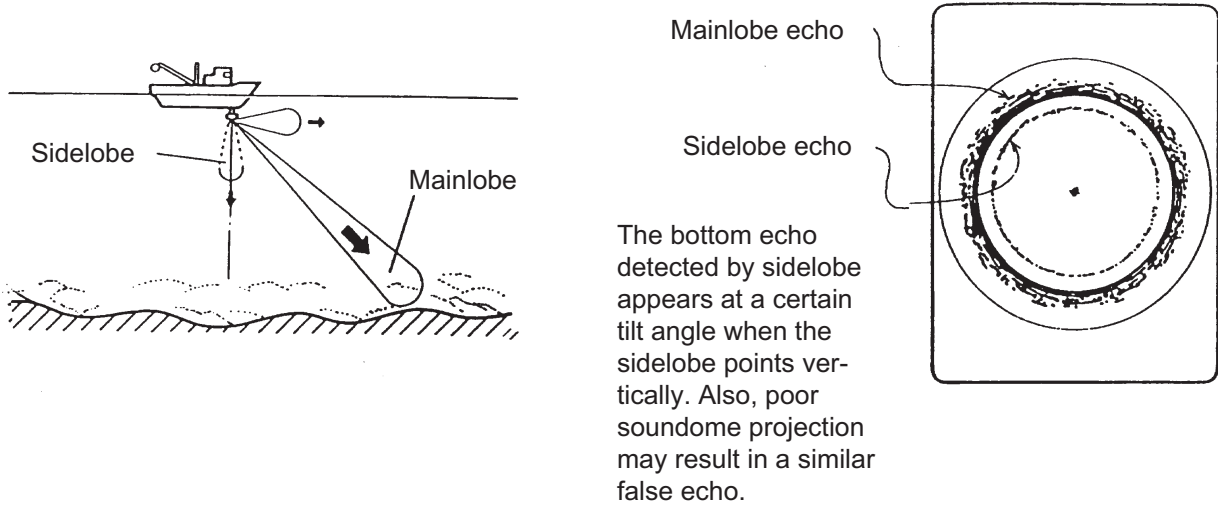

**Noise and interference**

When the fishing ground is crowded with many fishing boats, the sonar is subject to interference from ultrasonic equipment (echo sounder or sonar) on other boats as well as those on own ship.

For instance, interference from the sonar operated on other boats will show itself on the display as in (A) in the figure below. This interference can be suppressed by changing the TX interval, with [TX Interval] on the [H-Scan Setting] menu. Noise from marine life shows itself on the displays as in (B) in the figure below. This type of noise can be suppressed with the interference rejector on the [Picture Setting] menu.

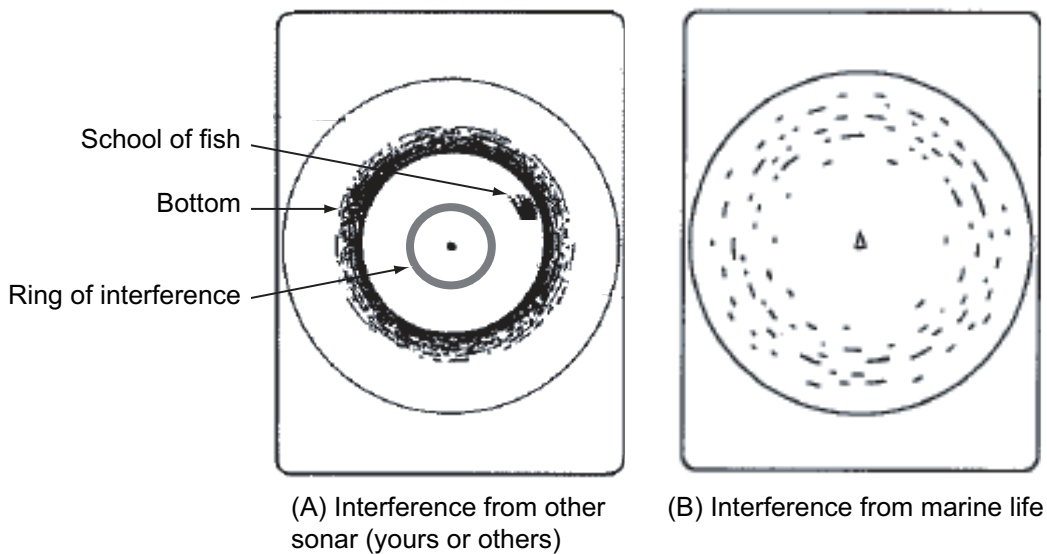

## 2. HORIZONTAL MODE

This page is intentionally left blank.



# 3. VERTICAL MODE

## 3.1 Basic Operating Procedure

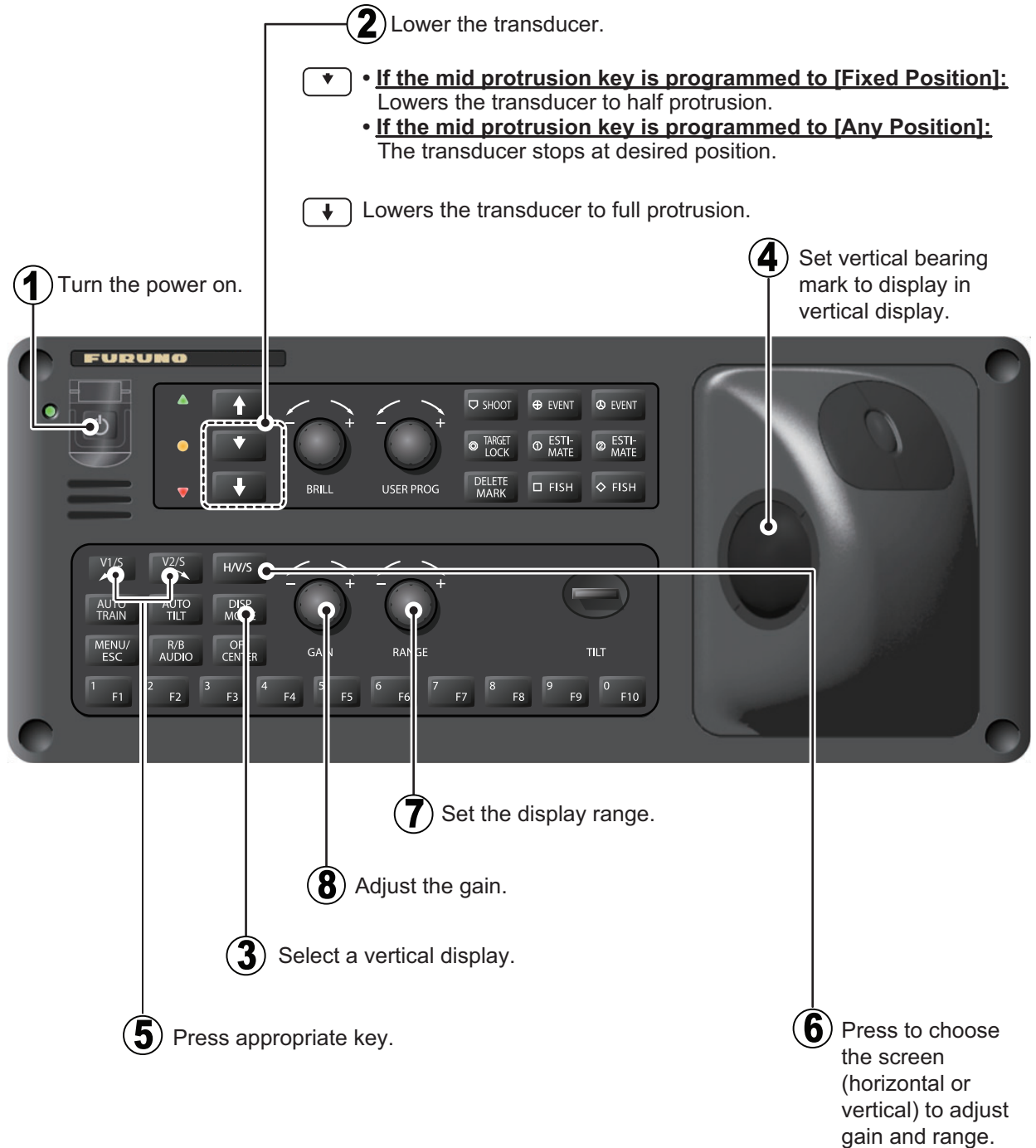

## 3.2 How the Vertical Mode Works

### 3.2.1 Overview

The vertical mode shows a vertical section of the horizontal display selected with the vertical bearing mark. The figure below illustrates the concept of the vertical mode, in comparison with the horizontal mode. The vertical mode helps you keep fast moving fish such as bonito and tuna within the sonar beam.

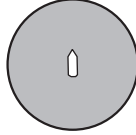
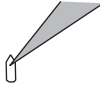
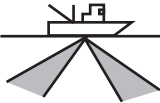
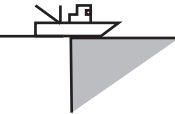
	Horizontal Mode	Vertical Mode
Detection aspect, view from top		
Detection aspect, view from side		

### 3.2.2 How to set the vertical display

1. Press the **DISP MODE** key to select [V1] or [V1 & V2].
2. Use the trackball to place the cursor at the desired location in the horizontal display.
3. Press the **V1/S** or **V2** key.

For example, press the **V1/S** key. Then, the Vertical 1 display appears, and the vertical bearing marker is displayed in the horizontal display, with V at the tip of the marker as shown on page 3-3. If both vertical displays are activated 1 or 2 is inscribed at the tip of a vertical bearing marker.

**Note:** The **TILT** control functions as a bearing setting lever for the vertical display1 in the conditions mentioned below. The bearing of the vertical display1 changes clockwise when the **TILT** control is pressed upward and counterclockwise when pressed downward, changing in increments of two degrees.

- The item [Tilt Lever] in the [Display Setting] menu is set to [TILT & V1].
- The vertical screen is chosen with the **H/V/S** key in the vertical dual display mode.

### 3.3 Vertical Indications and Marks

#### 3.3.1 Typical vertical display

The vertical mode provides a vertical section of the horizontal picture. You may show the display on the right or left side of the screen in case of the vertical 1 mode. An expansion mode is available to enlarge the picture. To display the vertical mode, press the **DISP MODE** key and choose V1 or V1 & V2. The example below shows the V1 mode. You can move and change the window size of the vertical display 1 by drag and drop.

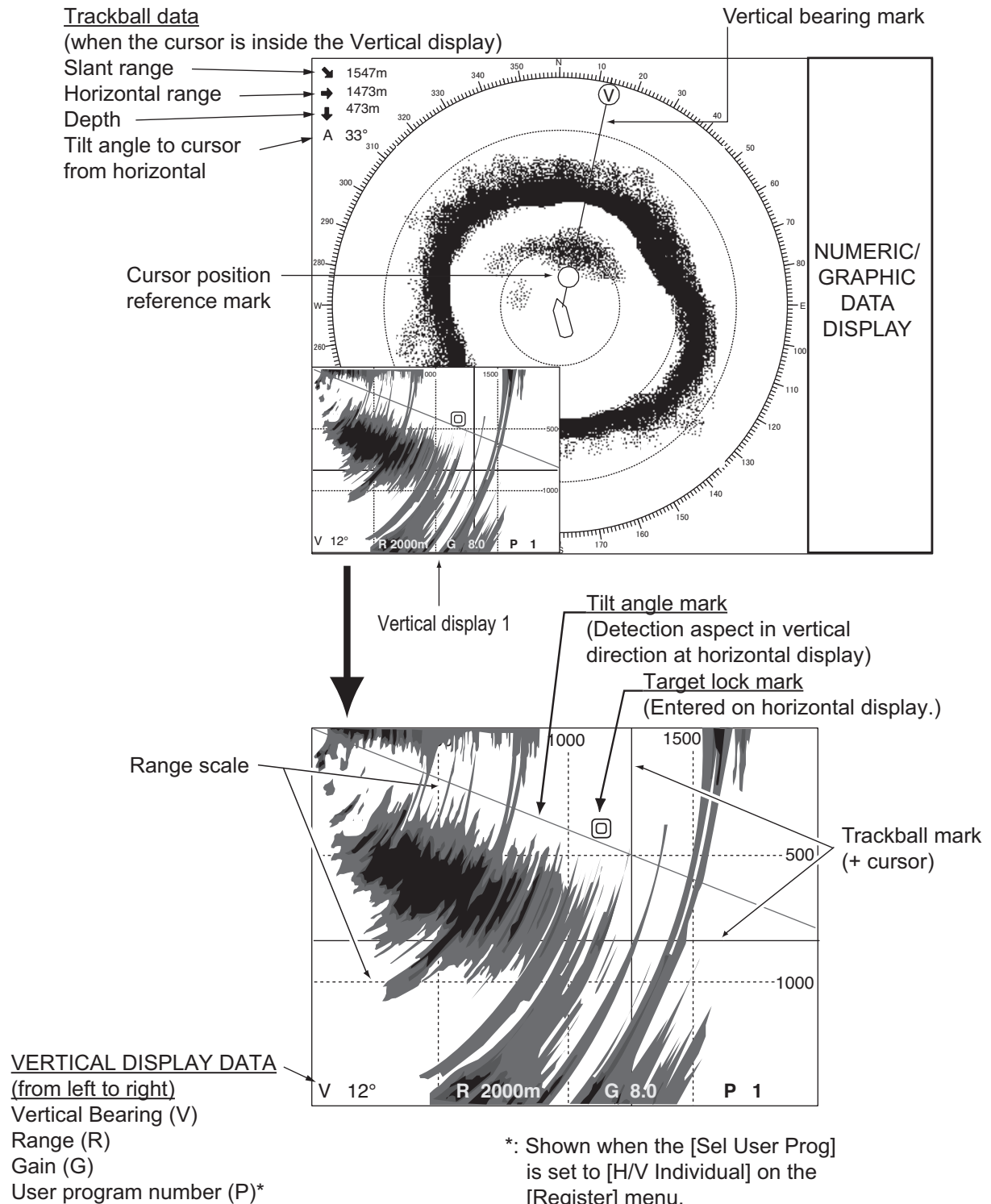

### 3. VERTICAL MODE

**Note:** When the settings listed below are changed, the setting value is shown at the top of the display for five seconds. The location of the setting value can be changed. Contact your dealer for details.

- Gain (See section 1.7.)
- Vertical bearing (See subsection 3.2.2.)
- User program (See section 6.3.)
- Display range (See section 3.5.)
- Auto train (See section 3.4.)

#### 3.3.2 Vertical bearing mark, tilt mark

The vertical bearing mark is displayed with solid and dashed lines and it shows the bearing selected on the horizontal display. The circle at the top of the vertical bearing mark has a V inside of it in the vertical 1 mode, or 1 and 2 as appropriate when both the vertical 1 and vertical 2 modes are active. Its bearing may be referenced to North (true) or ship's heading (relative, default setting) on the menu. (See "Monitor Setting menu" on page 7-8.)

The tilt mark is a solid and dashed line which shows in the vertical display the tilt angle set on the horizontal display.

The meaning of the solid and dashed lines are as shown in the table below.

	Solid line	Dash
Vertical bearing mark	Range from own ship to vertical scan range	Range further than vertical scan range
Tilt mark	Range from own ship to horizontal scan range	Range further than horizontal scan range

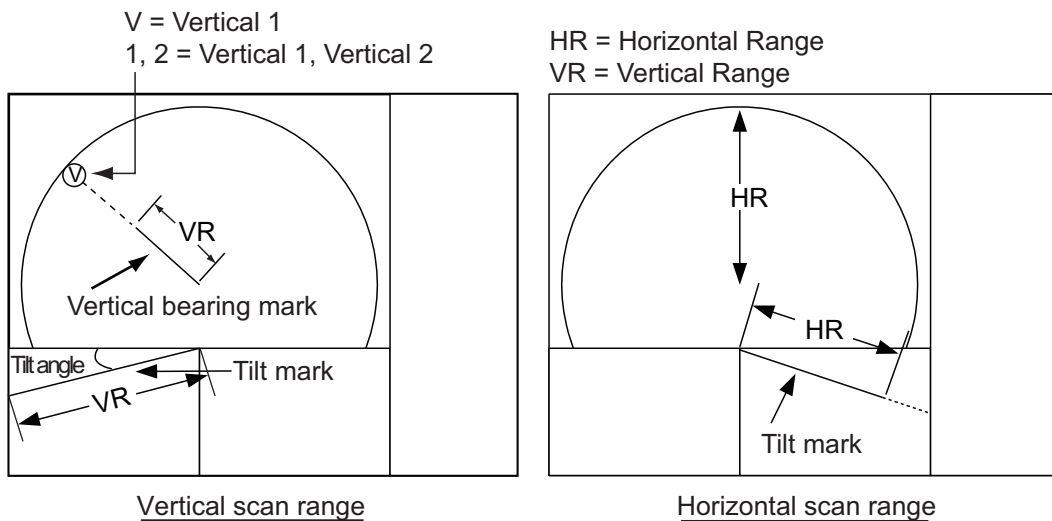

### 3.3.3 Cursor position reference mark

The cursor position reference mark, a solid circle, is inscribed on the vertical bearing mark when the cursor is placed in the vertical display. Its purpose is to show the corresponding cursor position on the horizontal display. It changes position with cursor position, tilt and range, and disappears when its position is no longer within the range of the horizontal display.

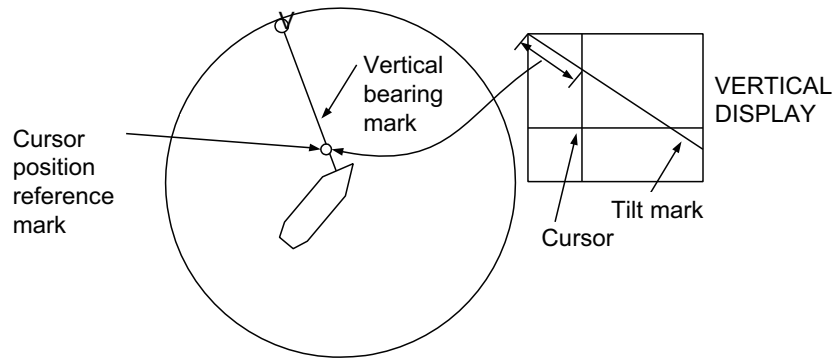

## 3.4 Auto Train

You may scan the vertical bearing mark in the sector of  $\pm 12^\circ$ ,  $\pm 24^\circ$  and  $\pm 36^\circ$ . Press and hold down the **AUTO TRAIN** key, then press the **V1/S** or **V2** key to select the auto train sector desired. Selected sector appears in large characters for five seconds for your confirmation. To cancel auto train, repeat the above procedure to select [OFF].

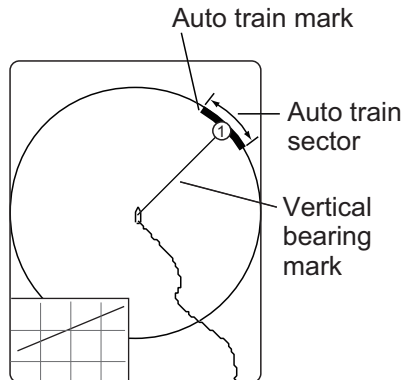

**Note:** When the target lock function is active in vertical mode, the following limitations apply to the auto train function:

- V1/S mode: Auto train is unavailable.
- V2 mode: Auto train is unavailable for vertical bearing mark 1.

Turn the target lock function off to re-enable the auto train function in these cases.

### 3.5 Display Range

The **RANGE** control selects the detection range. The range selected is momentarily displayed in large characters at the top of the vertical 1 display. Range is always displayed next to “R” at the lower part of the vertical 1 display.

The default ranges are as shown below (unit: m). In the vertical 2 combination display, the range for V1 and V2 are same.

Range No.	1	2	3	4	5	6
Detection range	100	200	400	600	800	1000

**Note:** Ranges can be preset. See page 7-6 for details.

1. Press the **H/V/S** key to show the range and gain indications of the horizontal mode to change the range (and gain).
2. Operate the **RANGE** control to select a range.

**Note:** The range can also be adjusted from the range indication. Put the cursor on the range indication to highlight it in yellow then roll the scrollwheel.

### 3.6 How to Measure the Range, Bearing to a Target

Operate the trackball to place the cursor on the vertical 1 (or vertical 2) display. The range to the location selected is shown at the top left corner.

Cursor data

(when the cursor is inside the Vertical display)

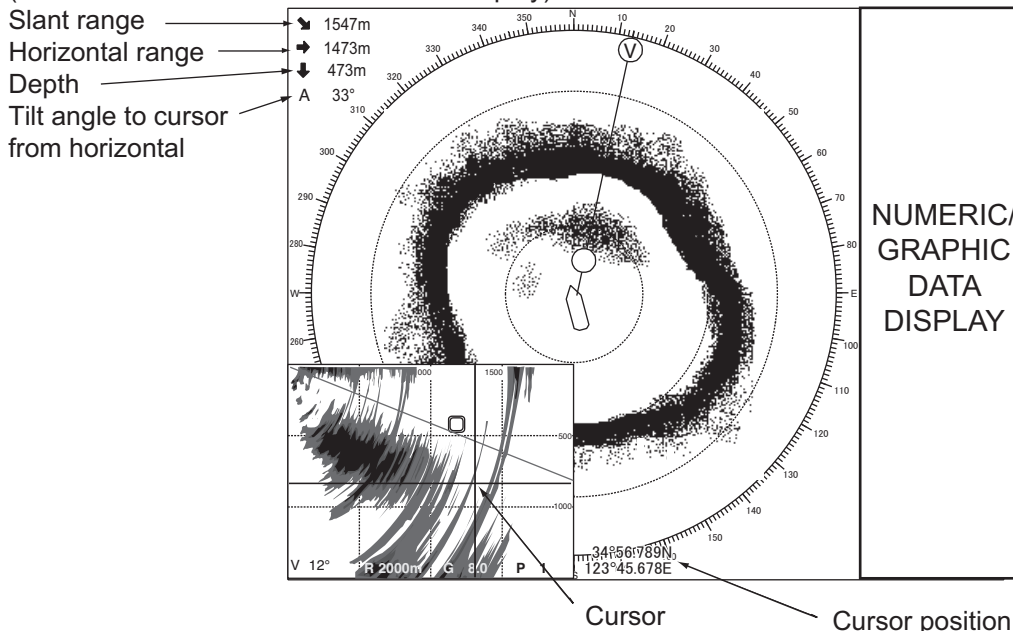

**Note:** To show the cursor position in L/L, see page 7-12.

## 3.7 How to Eliminate Weak Echoes

Echoes from targets such as bottom and fish return to the transducer in order of distance to them, and when we compare their intensities at the transducer face, those from nearer targets are generally stronger due to little propagation attenuation and little absorption. If these echoes are displayed directly on the screen, the size of the displayed echo from the same school of fish may change with distance, making it difficult to judge the actual size of the school of fish. To overcome this inconvenience use the TVG curve function. It compensates for propagation loss of sound in water; amplification of echoes on short range is suppressed and gradually increased as range increases so that similar targets are displayed in the similar intensities irrespective of the ranges to them.

### TVG curve

Four TVG curves are available and they vary the gain from large to small.

1. Press the **MENU/ESC** key to show the main menu.
2. Select [Gain Setting] then push the left-click button.
3. Press the **H/V/S** key to select [V] tab.

Gain Setting		Quit
H1	H2	S
TVG-Near		:5
TVG-Medium		:4
TVG-Far		:2
TVG Distance...		
Sel. TVG Curve		:TVG 3
AGC		:0
Near AGC...		
2nd AGC...		
Absorption Coeff.		:AUTO
Gain Control		:Wide

4. Select [Sel. TVG Curve] then push the left-click button.

Quit
Cancel
TVG 1
TVG 2
TVG 3
TVG 4

5. Select a curve then push the left-click button. The smaller the number the gentler the gain change over distance.
6. Select [Quit] on the setting box then push the left-click button.
7. Long-press the **MENU/ESC** key to close all menus.  
The TVG is also used to suppress unwanted echoes (sea surface reflections, cruising noise, etc.) on near ranges. If the selected curve does not provide satisfactory results, try to adjust TVG-Near, TVG-Medium or TVG-Far, as shown below.

### 3. VERTICAL MODE

#### **TVG distance and setting**

This sonar has three TVG functions, Near, Medium and Far, and they mainly compensate for propagation loss on short, middle and long ranges respectively, centered at the ranges shown below. The higher the TVG setting the greater the amplification of echoes.

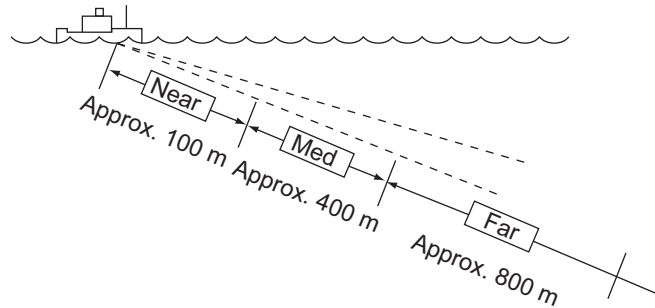

1. Press the **MENU/ESC** key to show the main menu.
2. Select [Gain Setting] then push the left-click button.
3. Press the **H/V/S** key to select the [V] tab.
4. Select [TVG Distance] then push the left-click button.
5. Select [Changeable] then push the left-click button.

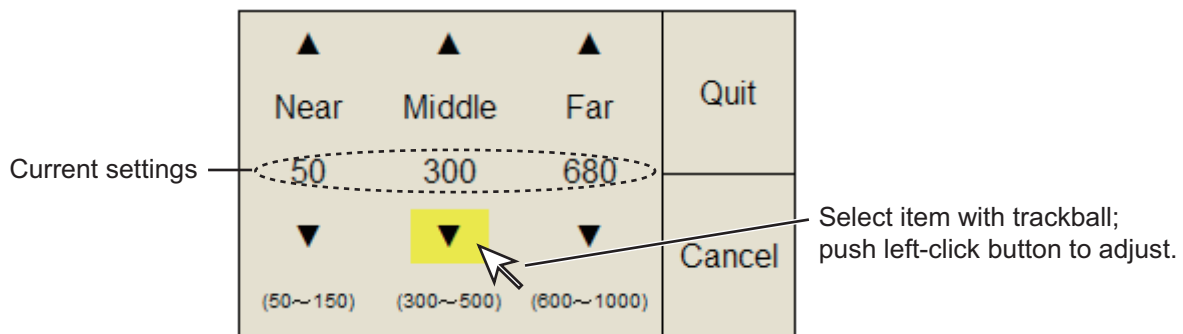

6. Select [Near], [Middle] or [Far] as appropriate then push the left-click button to change the setting.  
Near: Setting range, 50 - 150 m, 10 m increments. Middle: Setting range, 300 - 500 m, 20 m increments Far: Setting range, 600 - 1000 m, 40 m increments
7. Select [Quit] on the setting box then push the left-click button.  
Adjust the TVG level for selected TVG distance as follows.
8. Select [TVG-Near], [TVG-Medium] or [TVG-Far] as appropriate then push the left-click button.
9. Select ▲ or ▼ as appropriate then push the left-click button to change the setting. The setting range is -5 to 5. The higher the setting, the higher the gain. For strong echoes such as sea surface reflections or plankton layer lower the setting by 1 or 2.
10. Select [Quit] on the setting box then push the left-click button to close the box.
11. Long-press the **MENU/ESC** key to close all menus.



## 3.8 How to Adjust Strong and Weak Echoes

### 3.8.1 AGC

The AGC functions to automatically reduce the receiver gain only against strong echoes such as the bottom or a large school of fish. Since weak echoes remain unaffected, a small school of fish becomes easier to detect. Adjust it so that the AGC works only on bottom reflections. Do not set it too high; weak echoes may be missed.

1. Press the **MENU/ESC** key to show the main menu.
2. Select [Gain Setting] then push the left-click button.
3. Press the **H/V/S** key to select the [V] tab.
4. Select [AGC] then push the left-click button.
5. Select ▲ or ▼ then push the left-click button to change the setting.  
The setting range is -20 to 20. The higher the setting, the higher the degree of suppression.
6. Select [Quit] on the setting box then push the left-click to close the box.
7. Long-press the **MENU/ESC** key to close all menus.

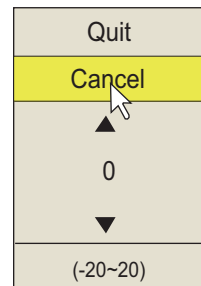

### 3.8.2 Near AGC

When the water is shallow or heavily sedimented, the reflected echoes from close-in and unwanted echoes may be excessively strong. In this case, a school of fish which is displayed at between 300 m to 500 m and beyond may disappear gradually when the ship starts approaching the school of fish.

Use the Near AGC feature to suppress this strong echo. Normally set it between 3 and 4, however, this setting depends on the sea area. Do not set it too high; all echoes (including noise) from near distance may be painted in red.

1. Press the **MENU/ESC** key to show the main menu.
2. Select [Gain Setting] then push the left-click button.
3. Press the **H/V/S** key to select the [V] tab.
4. Select [Near AGC] then push the left-click button to show the setting dialog box.
5. Select [Near AGC] again then push the left-click button.

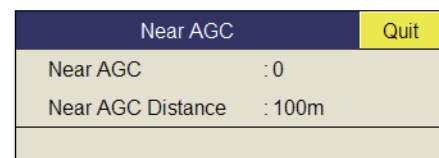

6. Select ▲ or ▼ then left-click to change the setting.  
The setting range is -20 to 20. The higher the setting, the stronger the echo level on near range.
7. Select [Quit] on the setting box then push the left-click button to close the box.
8. Long-press the **MENU/ESC** key to close all menus.

**Note:** Set the effective range of [Near AGC] with [Near AGC Distance]. The setting range is 20 - 2000 m, in 20 m increments. The setting range can be changed in the system menu. For details, contact your dealer.

### 3.8.3 2nd AGC

While it is ideal to suppress bottom echoes with the AGC alone there are some fishing grounds where this is not possible. (The high power sonar has the advantage of long-range detection but this can also be a disadvantage, since weaker echoes may be hidden in strong, unwanted echoes such as the bottom.) If you cannot suppress bottom echoes or sea surface reflections by the AGC function alone, use the 2ND AGC feature. Normally a setting of 1 or 2 is suitable. For especially strong echoes, use a setting of 3 or 4.

1. Press the **MENU/ESC** key to show the main menu.
2. Select [Gain Setting] then push the left-click button.
3. Press the **H/V/S** key to select the [V] tab.
4. Select [2nd AGC] then left-click to show the setting box.
5. Select [2nd AGC] again then push the left-click button.
6. Select ▲ or ▼ then push the left-click button to change the setting.  
The setting range is 0 to 20. The higher the setting, the stronger the suppression on long range.
7. Select [Quit] on the setting box then push the left-click button to close the box.
8. Long-press the **MENU/ESC** key to close all menus.

2nd AGC		Quit
2nd AGC	: 14	
Distance	: 20m	
Type	: Normal	
Post2nd AGC-Near	: 5	
Post2nd AGC-Far	: 5	
Post2nd AGC Dist	: 100m	
Exclusive Rng S	: ±20°	

#### **Other AGC-related items on the [2ND AGC] menu**

**Distance:** Set the start range for the 2nd AGC. The setting range is 0 - 2000 m, in 20 m increments. 2nd AGC is inoperative if the display range is lower than the 2nd AGC start range.

**Type:** Select the TVG type for 2nd AGC. Select [Normal] for everyday use.

### 3.8.4 How to shorten pulse length

The pulse length determines the length of the transmission pulse emitted into the water. While a longer pulse is advantageous for long-range sounding, it has the disadvantage of being poor in discrimination of targets, that is, the ability to separate several closely located targets. When searching bottom fish, therefore, it is useful to shorten the pulse length in order to separate fish echoes from bottom reflections. Decrease the pulse length setting to shorten the pulse length.

**Note:** When searching for surface or midwater fish in which bottom reflections are not so strong, use the longest pulse length 9.

1. Press the **MENU/ESC** key to show the main menu.

2. Select [TX/RX Setting] then push the left-click button.

TX/RX Setting			Quit
H1	H2	S	V
TX Interval		:9	
TX Pulse Length		:9	
TX Power		:9	
Frequency...			
Sidelobe Sup...			
Reverberation		:0	
Beam Width...			

3. Press the **H/V/S** key to select the [V] tab.
4. Select [TX Pulse Length] then push the left-click button.
5. Select ▲ or ▼ then push the left-click button to change the setting. The setting range is 0-9. The higher the setting, the longer the pulse length.
6. Select [Quit] on the setting box then push the left-click button to close the box.
7. Long-press the **MENU/ESC** key to close all menus.

## 3.9 How to Reject Sonar Interference and Noise

While observing the sonar picture, you may encounter occasional or intermittent noise and interference. These are mostly caused by on-board electronic equipment, engine or propeller noise, or electrical noise from other sonars being operated nearby.

### 3.9.1 How to identify the noise source

To eliminate noise effectively, you should first identify the noise source as follows:

1. Stop transmission on the [Test] menu; turn on [TX]. Turn on the power of all on-board equipment one by one while observing the picture. If noise appears on the sonar display, that equipment is emitting noise. Check the offending equipment's ground and installation.
2. Run the boat at various speeds to check if the noise is speed dependent.

If neither of the above two steps has effect on the picture, adjust one of the following:

### 3.9.2 Interference rejector

This control is similar to the interference rejector on echo sounders and radars. It is effective for rejecting random noise and sea surface reflections in rough sea conditions. Set it so that noise is just eliminated. Do not use an unnecessarily high setting since it may also reject small wanted echoes.

1. Press the **MENU/ESC** key to show the main menu.
2. Select [Picture Setting] then push the left-click button.
3. Press the **H/V/S** key to select the [V] tab.
4. Select [Int Reject] then push the left-click button.
5. Select ▲ or ▼ then push the left-click button to change the setting. The setting range is [0] to [3]. The degree of rejection, in ascending strength, is [2], [1], [3]. [0] disables the interference rejector.
6. Select [Quit] on the setting box to close the box.
7. Long-press the **MENU/ESC** key to close all menus.

Picture Setting		Quit	
H1	H2	S	V
Echo Average	:	2	
Int Reject	:	0	
Smooth Echo RNG	:	3	
Smooth Echo CIR	:	1	
A-Train Echo Average	:	2	
A-Train Int Reject	:	0	

### 3.9.3 Shift TX frequency

If the interference cannot be suppressed by the interference rejector or change in TX interval, shift the Tx frequency with the [Frequency] menu.

1. Press the **MENU/ESC** key to show the main menu.
2. Select [TX/RX Setting] then push the left-click button.
3. Press the **H/V/S** key to select the [V] tab.
4. Select [Frequency] then push the left-click button.
5. Select [Freq Shift1] then push the left-click button.

Frequency		Quit
Freq Shift1	:	0
Freq Shift2	:	-65
Freq/Bearing Set	:	0°

6. Select ▲ or ▼ then push the left-click button to change the setting. The setting range is -65 to 65.
7. Select [Quit] on the setting box then push the left-click button.
8. Long-press the **MENU/ESC** key to close all menus.

**Note 1:** In some cases the frequency cannot be changed because of operating bandwidth. In this case the frequency setting is grayed.

**Note 2:** The setting for [Freq Shift2] is valid when [Sidelobe Sup. A] is set between -3 and -1 (see subsection 3.9.7 for information on sidelobe suppression). Set [Freq Shift1] well apart from [Freq Shift2] to better suppress sidelobes.

### 3.9.4 Noise limiter

Weak, unwanted reflections, colored light-blue or green, are caused by dirty water, plankton layers, or ship's noise. The noise limiter can reduce the effects of these unwanted reflections. Raising the setting causes unwanted reflections to be displayed in colors of blue to background color.

1. Press the **MENU/ESC** key to show the main menu.
2. Select [Display Setting] then push the left-click button.
3. Press the **H/S/V** key to select the [V] tab.

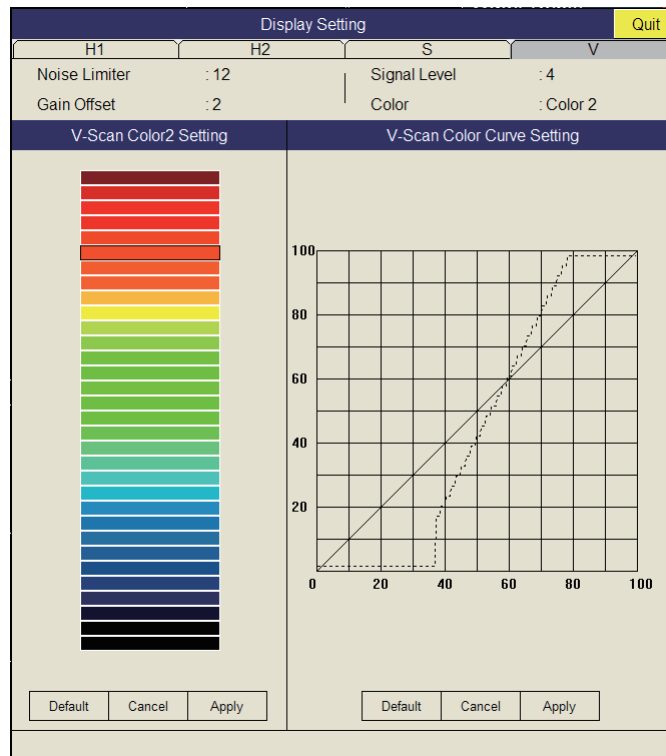

4. Select [Noise Limiter] then push the left-click button.
5. Select ▲ or ▼ then push the left-click button to set the value (setting range: 0 to 15).
6. Select [Quit] on the setting box then push the left-click button to close the box.
7. Long-press the **MENU/ESC** key to close all menus.

### 3.9.5 Reverberation

You may choose the length of reverberation for the echo signal, with [Reverberation] in the [TX/RX Setting] menu on the [V] tab. The larger the value, the lower the reverberation effect, which makes it easier to see the echo signal. The setting range is 0-3.

### 3.9.6 Echo average

[Echo Average] on the [Picture Setting] menu in the [V] tab adjusts echo afterglow - the amount of time an echo signal remains on the screen. This feature can be useful for watching echo movement. The setting range is 0-7. **Setting between 1 and 3:** Echoes are gradually displayed and afterglow remains on the screen longer as the setting is increased. **Setting between 4 and 7:** Echoes are quickly displayed and afterglow remains on the screen longer as the setting is increased.

### 3.9.7 How to suppress sidelobes

False echoes produced by sidelobes may appear on the display depending on the distribution pattern of a school of fish and the positional relationship between it and a marine object (reef, etc.) and wake reverberation. To reduce these sidelobes, use [Sidelobe Sup.] on the [TX/RX Setting] menu on the [V] tab.

Sidelobe Sup.		Quit
Sidelobe Sup.A	: 3	
Sidelobe Sup.B	: 2	
Sidelobe Dir1	: 60°	
Sidelobe Dir2	: 120°	

Watch the echoes while adjusting the suppression. Under normal conditions, [Sidelobe A] is adjusted. The setting range is -3 to 3 (0 is OFF). The larger the setting, the more the sidelobe is suppressed. For greatest suppression, use a negative setting (-3 to -1).

**Note:** When a negative value is used, [TX/RX Mode] in the [Display Setting] menu is automatically selected to [Alternative]. See "Display Setting Menu" on page 7-3 for details.

For greater sidelobe suppression, use [Sidelobe Sup. B]. See "Sidelobe suppression B" on page 2-19 for more information. Note that You cannot operate [Sidelobe Direction 1] and [Sidelobe Direction 2].

## 3.10 How to Adjust Beam Width

The width of the horizontal beam can be adjusted from the [Beam Width] menu.

1. Press the **MENU/ESC** key to show the main menu.
2. Select [TX/RX Setting] then push the left-click button.

Beam Width		Quit
Beam Control	: Manual	
TX Beam Width	: 1	
Hor. RX Beam Wid	: 1	
Ver. RX Beam Wid	: 1	
RX Beam Control	: 0	

3. Press the **H/V/S** key to select the [V] tab.
4. Select [Beam Width] then push the left-click button.
5. Select the item to set then push the left-click button.

### Description of Beam Width menu

**Beam Control:** Control the beamwidth according to option selected. Manual: Select this item to enable adjustment of the other items in this menu. Range: The beamwidth is automatically controlled with the range setting.

**TX Beam Width\*:** Increase the value to display close-range echoes clearly.

**Hor. RX Beam Width\*:** Increase the value to improve horizontal resolution.

**Ver. RX Beam Width\*:** Increase the value to improve vertical resolution to distinguish fish echoes from bottom echoes.

**RX Beam Control:** Increase the value to improve horizontal resolution.

**Note:** When [RX Beam Control] is set to 1 - 3 and [Sidelobe Sup.B ] is set to other than 0, [TX/RX Mode] on the [Display Setting] menu is automatically selected to [Alternative]. See "Display Setting Menu" on page 7-3 for details.

\*: Available only when [Beam Control] is set to [Manual].

6. Select [Quit] on the setting box then push the left-click button to close the box.
7. Long-press the **MENU/ESC** key to close all menus.

### 3.11 Other Menu Items

This section describes menu items which have not been explained yet.

#### Gain Setting menu

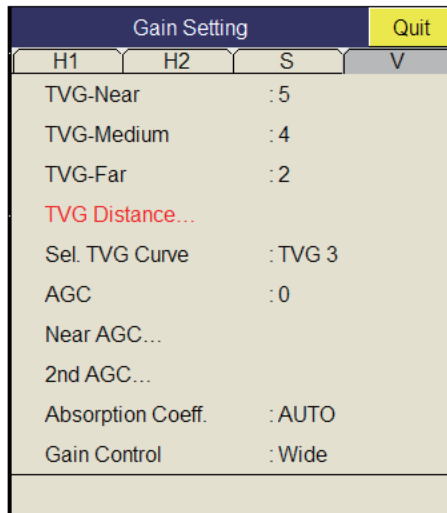

**Gain Control:** If the amount of gain change affected with the **GAIN** control on the front panel is too low, change the setting to [Wide], to double the range of the control.

#### Display Setting menu

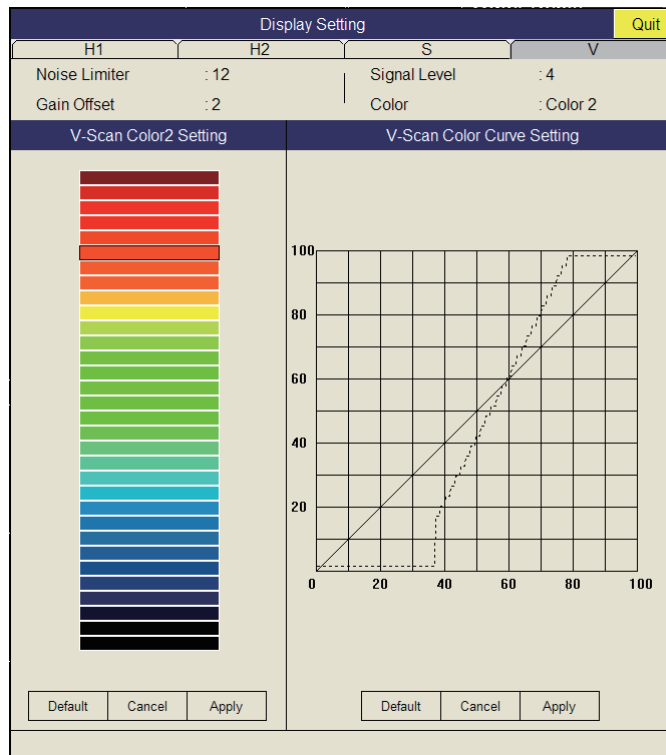

**Gain Offset:** Adjusts gain level. If the **GAIN** control on the front panel does not provide satisfactory gain adjustment, enter an offset here. The setting range is 0-12.

**Signal Level:** Contaminated water or reflections from plankton may be painted on the screen in green or light-blue. These echoes may be erased in order of strength. The setting range is 0-15; 0 corresponds to the weakest color.



**Color:** Select color arrangement to use. The default setting is Color 1.

**V-Scan Color 1 (2 to 4) Setting:** Customizes colors.

**V-Scan Color Curve Setting:** Adjusts reflected echo strength versus echo color level for currently selected color response number.

### Picture Setting menu

Picture Setting		Quit	
H1	H2	S	V
Echo Average		: 2	
Int Reject		: 0	
Smooth Echo RNG		: 3	
Smooth Echo CIR		: 1	
A-Train Echo Average		: 2	
A-Train Int Reject		: 0	

**Smooth Echo RNG:** Selects echo smoothing level in the range direction. The setting range is 0-7. The higher the setting, the greater the smoothing.

**Smooth Echo CIR:** Selects echo smoothing level in the circular direction. The setting range is 0-5. The higher the setting, the greater the smoothing.

## 3.12 Usage in Bonito and Tuna Fishing

Tracking of bonito and tuna presents a special challenge to the sonar operator: He must try to keep them within the sonar beam, a formidable task considering their high speed and penchant for leaping and diving. However, the vertical display, with its wide range in the vertical direction, makes this task easier.

### 3.12.1 Searching

Neither the naked eye nor binoculars can continually track schools of fish which make lightning quick runs between the surface and midwater. A sonar, however, provides a continuous view of several hundred meters of sea area around the boat, both at the surface and below it.

### 3.12.2 Tracking

If you are visually tracking a school of fish which characteristically leaps and dives regularly, or a school with a flock of birds hovering over it, the school will scatter once the vessel approaches, thus you will lose sight of the school. This sonar provides continuous pictures of underwater conditions, so you can always know where a school of fish is. For tracking the schools which leap and dive often the vertical mode is especially effective.

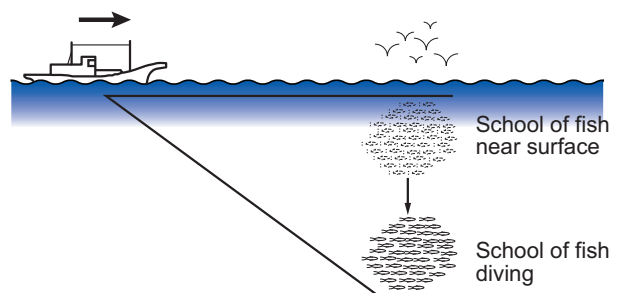

### 3.12.3 Approaching

The sonar lets you view the movement of a school of fish continuously, thus you can approach a school confident of a good catch.

While a flock of birds hovering over the sea surface is usually a good indication of the presence of a school of fish, the sonar can better verify the size of a school of fish.

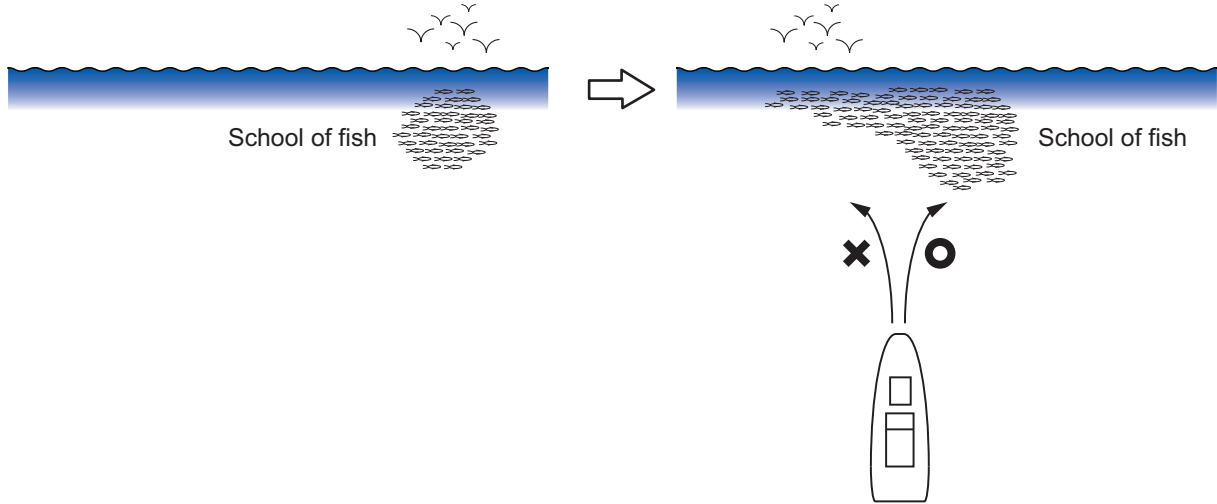

### 3.12.4 Catching

While the sonar operator monitors the sonar for other schools of fish, the crew can scatter bait and water to attract fish to the boat.

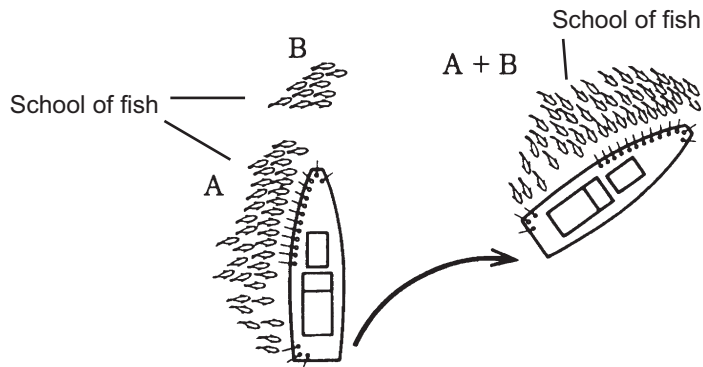

# 4. SLANT MODE

## 4.1 Basic Operating Procedure

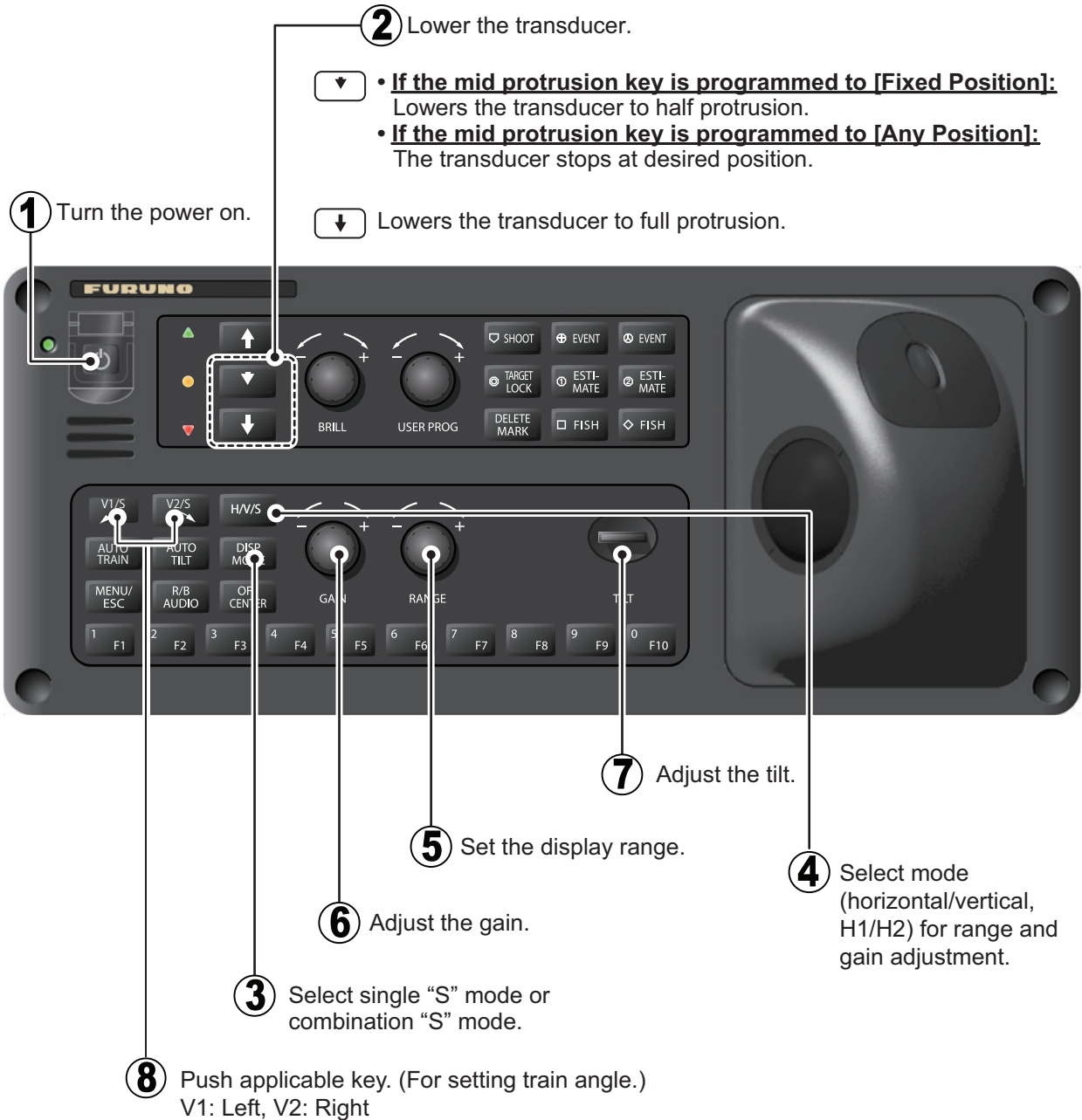

## 4.2 Indications and Marks

The picture produced by the slant mode is the same as that of the half-circle sonar picture. The slant mode provides a half-circle (180°) picture, with own ship at the center

### 4.2.1 Slant mode, full-screen display

To select the full-screen slant mode display, press the **MODE** key and select [S]. (To use the slant mode, presetting of the mode is required. **MENU/ESC** key - [Others] menu - [Register] - [Display Mode] - [S].)

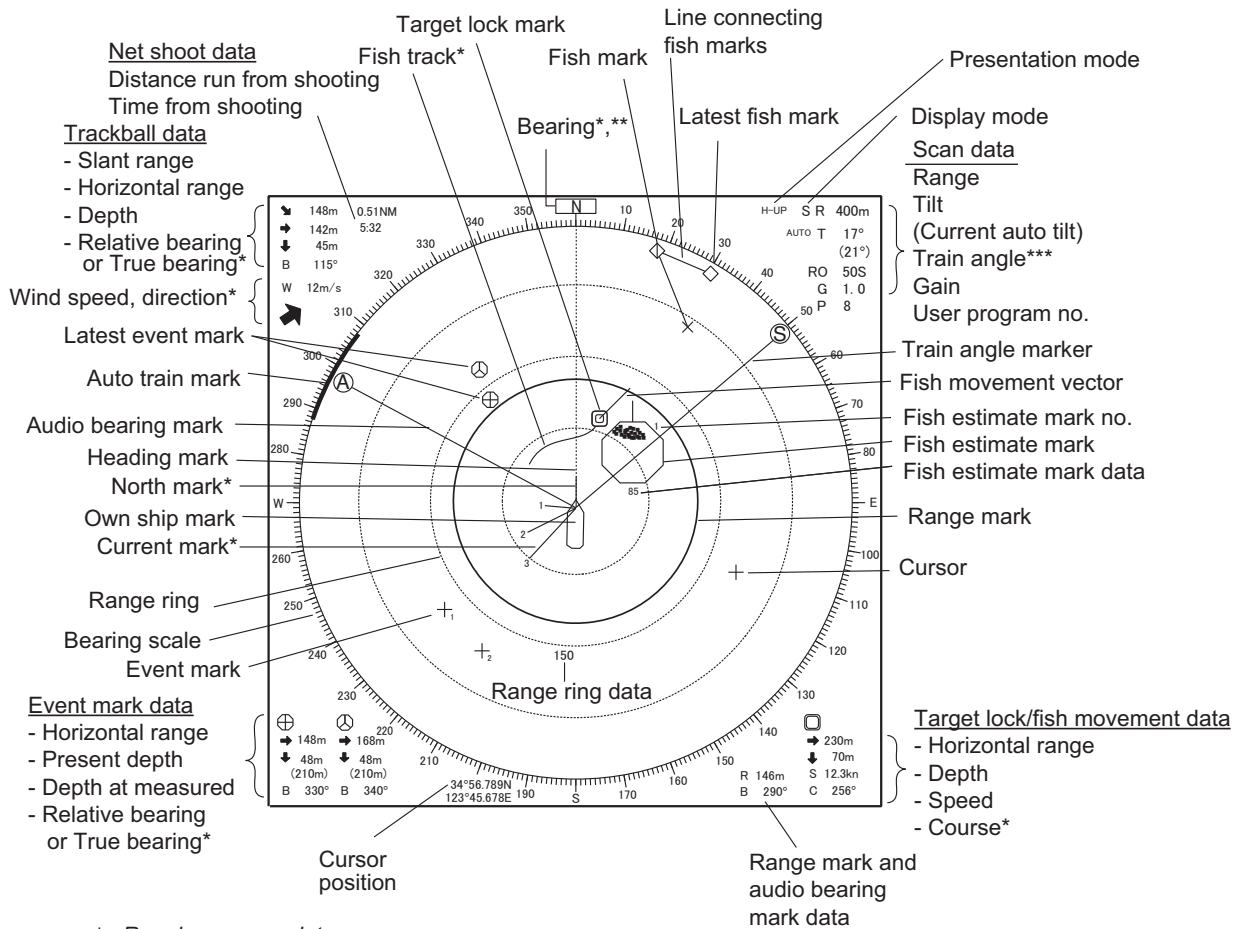

\*: Requires appropriate sensor.

\*\* : Shown with head-up mode.

\*\*\*: The Slant mode presents a half-circle picture. The data display is mostly the same as the horizontal mode except the train angle is shown. Appropriate sensors are required to display navigation data.

## 4.2.2 Slant mode, combination display

The slant mode combination display provides the slant and horizontal pictures. The pictures can be arranged in landscape, portrait and inset. The zoom-out display shown on the inset display can be moved or you can change the size with the drag and drop operation.

To select desired combination display do the following:

1. Press the **MENU/ESC** key to show the main menu.
2. Select [Others] then push the left-click button.
3. Select [Display Setting] then push the left-click button.

Display Setting		Quit
TX/RX Mode	: Alternative	
Mode Selection	: Mode Key	
Echo Disp Area	: Within Range	
<b>F9</b> H2/S Display	: Landscape	
2nd Monitor Setting	: Portrait	
V-Scan Aspect Ratio	: Fixed	
V-Scan Dpt Rng	: 100	
<b>F3</b> Presentation Mode	: Head Up	
TM Disp Range	: 1.6R	
Full Screen Area	: 1.6R	
Bearing Ref	: Ship Heading	
TILT lever	: Tilt	
Auto Tilt	: Narrow	
S Auto Off Cent	: OFF	
Net Course Mark	: Execute	
<b>F4</b> Dimmer	: 7	
Key Beep Volume	: 5	
TimerDisplay	: OFF	
Circle Cursor Diameter	: 200m	
Disp. Hull Unit Status	: ON	

4. Select [H2/S Display] then push the left-click button.



5. Select the item desired then push the left-click button.
6. Select [Quit] on the setting box then push the left-click button to close the box.
7. Long-press the **MENU/ESC** key to close all menus.

## 4.3 Display Range

The **RANGE** control selects the detection range and six ranges are preset at the factory. The range selected is momentarily displayed in large characters at the top of the screen. Range is always displayed next to "R" at the top right hand corner of the screen.

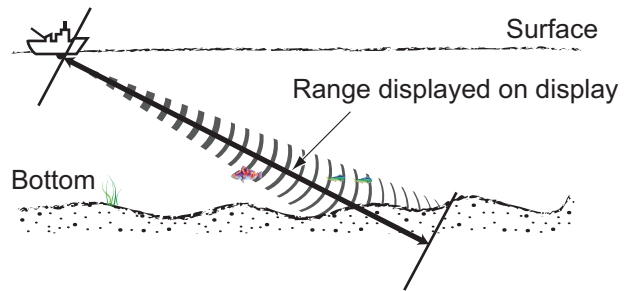

Range No.	1	2	3	4	5	6
Detection range	100 m	200 m	400 m	600 m	800 m	1000 m

**Note:** Ranges can be preset on the [Register] menu. See page 7-6.

1. Press the **H/V/S** key to select the slant mode.  
Range and user program no. are shown in orange.
2. Operate the **RANGE** control to select a range.

**Note 1:** The range can also be adjusted from the range indication. Put the cursor on the range indication to highlight it in yellow then roll the scrollwheel.

**Note 2:** In the target lock function, the range is automatically changed according to target position if [Tilt Interlock] ([Target Lock] menu) is selected to [Tilt & Range].

## 4.4 Tilt Angle

The tilt angle shows the direction to which the sound wave is emitted. When the sound wave is emitted horizontally, the tilt angle is said to be 0° and when vertically, 90°. The tilt angle can be set between -5° (upward) to 90° (downward), in increments of 1°.

### 4.4.1 How to set the tilt angle

To manually set a tilt angle, operate the **TILT** control. Watch the tilt angle indication and tilt angle indicator is momentarily displayed in large characters at the top of the screen. The tilt angle is always displayed next to "T" at the top right hand corner of the screen.

Select tilt angle depending on target fish. For surface fish select a shallow angle (about 5°) and for bottom fish, a deep angle.

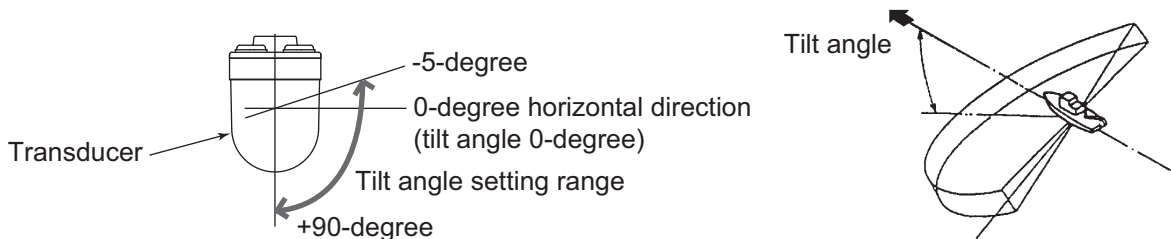

**Note 1:** The default function of the scrollwheel sets the tilt angle.

**Note 2:** The tilt angle can also be adjusted from the tilt angle indication. Put the cursor on the tilt angle indication to highlight it in yellow then roll the scrollwheel.

## 4.4.2 Automatic tilt

The **AUTO TILT** key automatically scans the tilt angle within the selected width. This is useful when you want to find the center depth of a school of fish. Wide tilt angle is activated from the [Auto Tilt] in the [Others] - [Display Setting] menu.

1. Press the **AUTO TILT** key to select auto tilt angle desired. Each time the key is pressed the auto tilt angle changes in the following sequence.

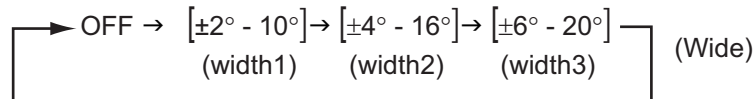
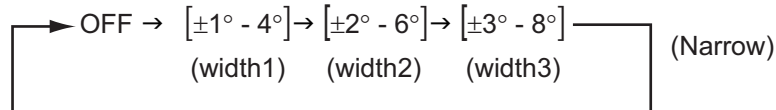

2. If necessary operate the **TILT** control to change center tilt angle.

### *Automatic tilt angle (narrow) with **AUTO TILT** key*

Range (m)	Width 1	Width2	Width3	Period
60, 100	$\pm 4^\circ$	$\pm 6^\circ$	$\pm 8^\circ$	Period: One transmission <b>Note:</b> Tilt angle changes in $2^\circ$ increments for asterisk-marked width; $1^\circ$ increments for all other widths.
150, 200	$\pm 2^\circ$	$\pm 4^\circ$	$\pm 6^\circ$	
300, 400	$\pm 1^\circ$	$\pm 2^\circ$	$\pm 4^\circ$	
500, 600	$\pm 1^\circ$	$\pm 2^\circ$	$\pm 3^\circ$	
700, 800	$\pm 1^\circ$	$\pm 2^\circ$	$\pm 3^\circ$	
900, 1000	$\pm 1^\circ$	$\pm 2^\circ$	$\pm 3^\circ$	
Over 1100	$\pm 1^\circ$	$\pm 2^\circ$	$\pm 3^\circ$	

### *Automatic tilt angle (wide) with **AUTO TILT** key*

Range (m)	Width 1	Width2	Width3	Period
60, 100, 150	$\pm 10^\circ$	$\pm 16^\circ$	$\pm 20^\circ$	Period: One transmission
200	$\pm 10^\circ$	$\pm 16^\circ$	$\pm 20^\circ$	
300, 400	$\pm 10^\circ$	$\pm 16^\circ$	$\pm 20^\circ$	
500, 600	$\pm 8^\circ$	$\pm 16^\circ$	$\pm 20^\circ$	
700, 800	$\pm 6^\circ$	$\pm 12^\circ$	$\pm 16^\circ$	
900, 1000	$\pm 4^\circ$	$\pm 8^\circ$	$\pm 12^\circ$	
Over 1100	$\pm 2^\circ$	$\pm 4^\circ$	$\pm 6^\circ$	

3. Auto tilt begins, with the tilt angle set with the **TILT** control as the center tilt angle.

For example, when the **RANGE** control, **TILT** control and **AUTO TILT** key are set to 800 m,  $8^\circ$  and width (1) respectively, the tilt angle changes at each transmission as follows:  $8^\circ \rightarrow 9^\circ \rightarrow 8^\circ \rightarrow 7^\circ \rightarrow 8^\circ$ .

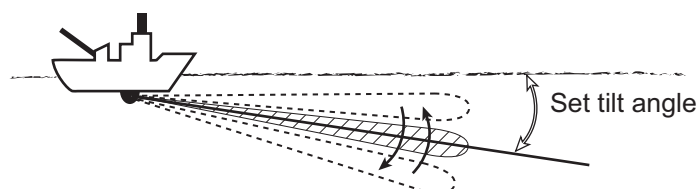

**Note 1:** The **AUTO TILT** key is inoperative when the target lock function is active or is made active. Auto tilt is resumed once target lock is disabled.

**Note 2:** If the picture set with auto tilt is not visible, disable auto tilt and try again.

## 4.5 Auto Train

This feature provide automatic training of the Tx and Rx beams in left and right directions to enable search over a wide area. This feature is inoperative when target lock is active.

1. Press the **V1/S** or **V2** key to set center angle for automatic training. Operate **V1/S** to change training leftward; **V2** to change training rightward.
2. While pressing the **AUTO TRAIN** key press the **V1/S** key to set train angle. The choices are [ $\pm 30^\circ$ ], [ $\pm 60^\circ$ ], [ $\pm 90^\circ$ ], [ $\pm 120^\circ$ ], [ $\pm 150^\circ$ ], [ $\pm 180^\circ$ ], [ $360^\circ$ ] and OFF. The [ $360^\circ$ ] setting will cause a clockwise  $360^\circ$  turn.

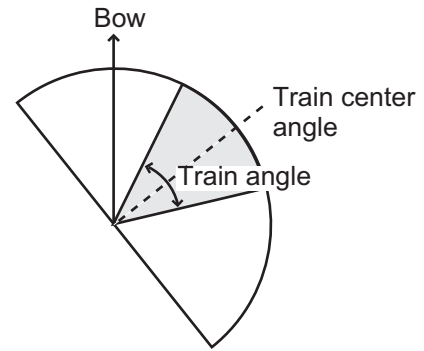

Auto train is automatically cancelled when target lock is activated, and the train angle is set where the target lock mark is entered. When target lock is disabled, auto train resumes from the bearing in use at the time of deactivation of target lock.

**Note:** When using the auto train function in slant mode, the train angle size is smaller than normal.

## 4.6 How to Measure Range and Bearing to a Target

Operate the trackball to place the cursor on the target you want to measure the range and bearing. The range, bearing and depth to the target appear at the upper left corner of the screen.

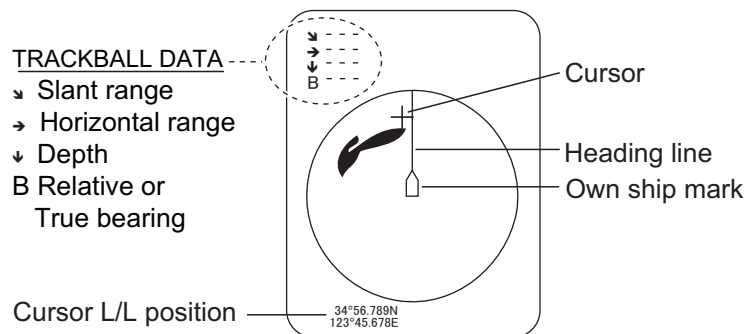

**Note 1:** Cursor position may also be shown in latitude and longitude. For further details, see page 7-12.

**Note 2:** The bearing display is available in four formats. See page 7-12.



## 4.7 How to Eliminate Weak Echoes

Echoes from targets such as bottom and fish return to the transducer in order of distance to them, and when we compare their intensities at the transducer face, those from nearer targets are generally stronger due to little propagation attenuation and little absorption. If these echoes are displayed directly on the screen, the size of the displayed echo from the same school of fish may change with distance, making it difficult to judge the actual size of the school of fish. To overcome this inconvenience use the TVG curve function. It compensates for propagation loss of sound in water; amplification of echoes on short range is suppressed and gradually increased as range increases so that similar targets are displayed in the similar intensities irrespective of the ranges to them.

### TVG curve

Four TVG curves are available and they vary the gain from large to small.

1. Press the **MENU/ESC** key to open the main menu.
2. Select [Gain Setting] then push the left-click button.
3. Press the **H/V/S** key to select the [S] tab.

Gain Setting		Quit
H1	H2	S
TVG-Near		:5
TVG-Medium		:5
TVG-Far		:2
TVG Distance...		
Sel. TVG Curve		:TVG 3
AGC		:0
Near AGC...		
2nd AGC...		
Absorption Coeff.		:26.5dB
Gain Control		:Wide

4. Select [Sel. TVG Curve] then push the left-click button.

Quit
Cancel
TVG 1
TVG 2
TVG 3
TVG 4

5. Select a curve then push the left-click button.  
The smaller the number, the gentler the gain change over distance.
6. Select [Quit] on the setting window then push the left-click button to close the box.
7. Long-press the **MENU/ESC** key to close all menus.  
The TVG is also used to suppress unwanted echoes (sea surface reflections, cruising noise, etc.) on near ranges. If the selected curve does not provide satisfactory results, try to adjust [TVG-Near], [TVG-Medium] or [TVG-Far], as shown below.

### **TVG distance and setting**

This sonar has three TVG functions, Near, Medium and Far, and they mainly compensate for propagation loss on short, middle and long ranges respectively, centered at the ranges shown below. The higher the TVG setting the greater the amplification of echoes. For details, see chapter 2.

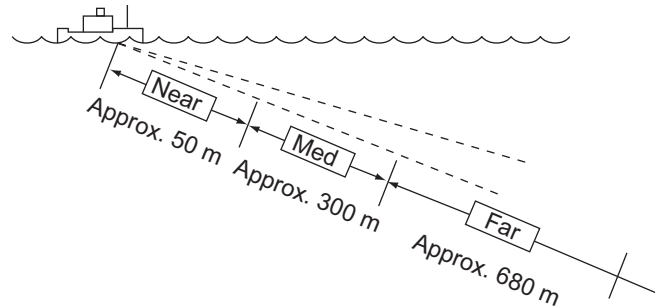

## **4.8 How to Adjust Strong and Weak Echoes**

### **4.8.1 AGC**

The AGC functions to automatically reduce the receiver gain only against strong echoes such as the bottom or a large school of fish. Since weak echoes remain unaffected, a small school of fish becomes easier to detect. Adjust it so that the AGC works only on bottom reflections. Do not set it too high; weak echoes may be missed.

1. Press the **MENU/ESC** key to show the main menu.
2. Select [Gain Setting] then push the left-click button.
3. Press the **H/V/S** key to select the [S] tab.
4. Select [AGC] then push the left-click button.

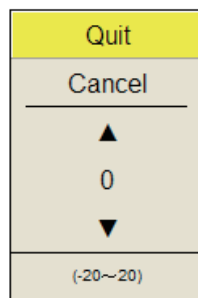

5. Select ▲ or ▼ then push the left-click button to change the setting. The setting range is -20 to 20. The higher the setting, the higher the degree of suppression.
6. Select [Quit] on the setting box then push the left-click button to close the box.
7. Long-press the **MENU/ESC** key to close all menus.

## 4.8.2 Near AGC

When the water is shallow or heavily sedimented, the reflected echoes from close-in, unwanted echoes may be excessively strong. In this case, a school of fish which is displayed at between 300 m to 500 m and beyond may disappear gradually when the ship starts approaching the school of fish.

Use the Near AGC feature to suppress this strong echo. Normally set it between 3 and 4, however, this setting depends on the sea area. Do not set it too high; all echoes (including noise) from near distance may be painted in red.

1. Press the **MENU/ESC** key to show the main menu.
2. Select [Gain Setting] then push the left-click button.
3. Press the **H/V/S** key to select the [S] tab.
4. Select [Near AGC] then push the left-click button.

Near AGC		Quit
Near AGC	: 0	
Near AGC Distance	: 100m	

5. Select [Near AGC] again then push the left-click button.
6. Select ▲ or ▼ then push the left-click button to change the setting.  
The setting range is -20 to 20. The higher the setting, the stronger the echo level on near range.
7. Select [Quit] on the setting box then push the left-click button to close the box.
8. Long-press the **MENU/ESC** key to close all menus.

**Note:** The effective range is set at [Near AGC Distance] on the [Near AGC] menu (20 m to 2000 m, 20 m step).

## 4.8.3 2nd AGC

While it is ideal to suppress bottom echoes with the AGC alone there are some fishing grounds where this is not possible. (The high power sonar has the advantage of long-range detection but this can also be a disadvantage, since weaker echoes may be hidden in strong, unwanted echoes such as the bottom.) If you can not suppress bottom echoes or sea surface reflections by the AGC function alone, use the 2ND AGC feature. Normally a setting of 1 or 2 is suitable. For especially strong echoes, use a setting of 3 or 4.

1. Press the **MENU/ESC** key to show the main menu.
2. Select [Gain Setting] then push the left-click button.
3. Press the **H/V/S** key to select the [S] tab.

## 4. SLANT MODE

4. Select [2nd AGC] then push the left-click button.

2nd AGC		Quit
2nd AGC	: 12	
Distance	: 0m	
Type	: Normal	
Post2nd AGC-Near	: 0	
Post2nd AGC-Far	: 0	
Post2nd AGC Dist	: 0m	
Exclusive Rng S	: ±0°	

5. Select [2nd AGC] again then push the left-click button
6. Select ▲ or ▼ then push the left-click button to change the setting.  
The setting range is 0 to 20. The higher the setting, the stronger the suppression on long range.
7. Select [Quit] on the setting box then push the left-click button to close the box.
8. Long-press the **MENU/ESC** key to close all menus.

### **Other AGC-related items on the [2nd AGC] menu**

**Distance:** Set the start range for the [2nd AGC]. The setting range is 0 - 2000 m, in 20 m increments. [2nd AGC] is inoperative if the display range is lower than the [2nd AGC] start range.

**Type:** Select the TVG type for [2nd AGC]. Select [Normal] for everyday use.

**Post2nd AGC-Near\*:** Set the near range threshold for [Post 2nd AGC]. The larger the figure, the greater the suppression.

**Post2nd AGC-Far\*:** Set the far range threshold for [Post 2nd AGC]. The larger the figure, the greater the suppression.

**Post2nd AGC-Distance\*:** Switch between Far and Near Post 2nd AGC.

\*The [Post 2nd AGC] functions independently of [2nd AGC]. If the [2nd AGC] cannot suppress the bottom echo or sea surface reflections, try to suppress them with the [Post 2nd AGC]. For particularly strong echoes raise the AGC setting.

### **4.8.4 How to shorten pulse length**

The pulse length determines the length of the transmission pulse emitted into the water. While a longer pulse is advantageous for long-range sounding, it has the disadvantage of being poor in discrimination of targets, that is, the ability to separate several closely located targets. When searching bottom fish, therefore, it is useful to shorten the pulse length in order to separate fish echoes from bottom reflections. Decrease the pulse length setting to shorten the pulse length.

**Note:** For search of surface and midwater fish in which bottom reflections are not so strong, use the longest pulse length [9].

1. Press the **MENU/ESC** key to show the main menu.
2. Select [TX/RX Setting] then push the left-click button.

- Press the **H/V/S** key to select the [S] tab.

TX/RX Setting			Quit
H1	H2	S	V
TX Interval		:9	
TX Pulse Length		:9	
TX Power		:9	
Frequency...			
Sidelobe Sup...			
Reverberation		:0	
Beam Width...			

- Select [TX Pulse Length] then push the left-click button.
- Select ▲ or ▼ then push the left-click button to adjust the setting. The setting range is 0-9. The higher the setting, the longer the pulse length.
- Select [Quit] on the setting box then push the left-click button to close the box.
- Long-press the **MENU/ESC** key to close all menus.

## 4.9 How to Suppress Bottom and Sea Surface Reflections in Shallow Waters

In shallow fishing grounds with hard or rocky bottom, bottom reflections often interfere with wanted fish echoes and they can not be eliminated sufficiently with the aforementioned TVG and AGC functions, especially when the TILT is set to a larger angle in order to track schools of fish approaching within 400 m. In such cases try to reduce the output power by adjusting the Tx output instead of turning down the gain. The picture becomes clearer when output power is reduced rather than when the GAIN is decreased as illustrated below.

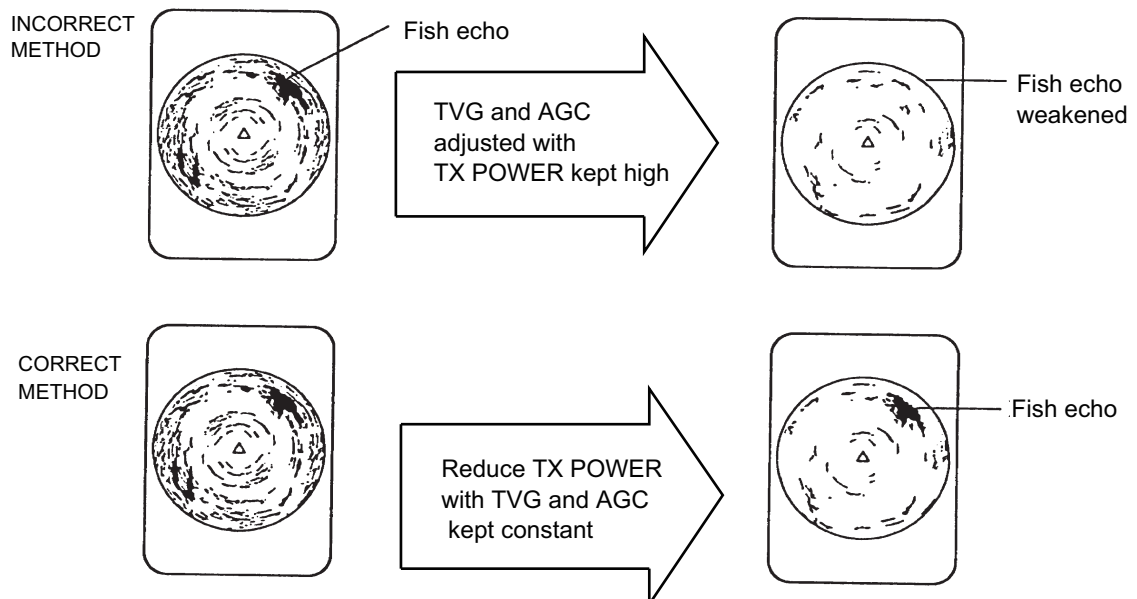

- Press the **MENU/ESC** key to show the main menu.
- Select [TX/RX Setting] then push the left-click button.
- Press the **H/V/S** key to select the [S] tab.

## 4. SLANT MODE

4. Select [TX/RX Power] then push the left-click button.
5. Select ▲ or ▼ then push the left-click button to adjust the setting. The setting range is 0-9. The higher the setting, the greater the TX power.
6. Select [Quit] on the setting box then push the left-click button to close the box.
7. Long-press the **MENU/ESC** key to close all menus.

## 4.10 How to Reject Sonar Interference and Noise

While observing the sonar picture, you may encounter occasional or intermittent noise and interference. These are mostly caused by on-board electronic equipment, engine or propeller noise, or electrical noise from other sonars being operated nearby.

### 4.10.1 How to identify the noise source

To eliminate noise effectively, you should first identify the noise source as follows:

- 1) Stop transmission on the [Test] menu; turn on [TX]. Turn on the power of all on-board equipment one by one while observing the picture. If noise appears on the sonar display, that equipment is emitting noise. Check the offending equipment's ground and installation.
- 2) Run the boat at various speeds to check if the noise is speed dependent.

If neither of the above two steps has effect on the picture, adjust one of the following:

### 4.10.2 Change TX interval

When other sonars nearby are operating the same transmission interval as that of own ship's sonar, rings of interference appears on the display.

To remove the rings from the screen, do the following:

1. Press the **MENU/ESC** key to show the main menu.
2. Select [TX/RX Setting] then push the left-click button.
3. Press the **H/V/S** key to select the [S] tab.
4. Select [TX Interval] then push the left-click button.
5. Select ▲ or ▼ then push the left-click button to change the setting. The setting range is 0-9. The higher the setting, the longer the TX interval. [EXT KP] is for external KP synchronization; however, adjustment on the System menu is required. See the installation manual.
6. Select [Quit] for the setting box then push the left-click button to close the box.
7. Long-press the **MENU/ESC** key to close all menus.

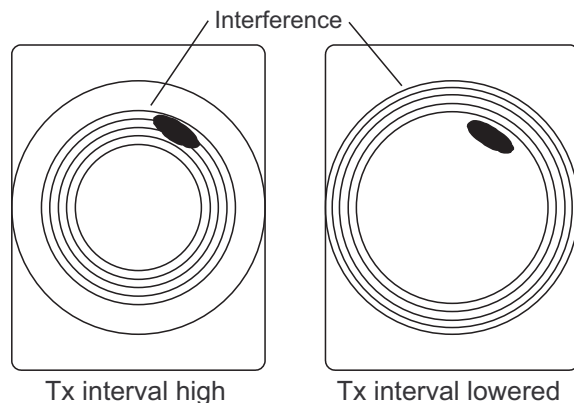

**Note:** When you operate the sonar with the following settings in shallow water, the sea clutter from the previous transmission may appear in near range. To suppress the clutter, reduce [TX Interval] by 2 or 3.

- Range: 60 to 200 m
- TX Pulse setting: 9

### 4.10.3 Interference rejector

This control is similar to the interference rejector on echo sounders and radars. It is effective for rejecting random noise and sea surface reflections in rough sea conditions. Set it so that noise is just eliminated. Do not use an unnecessarily high setting since it may also reject small, wanted echoes.

1. Press the **MENU/ESC** key to show the main menu.
2. Select [Picture Setting] then push the left-click button.
3. Press the **H/V/S** key to select the [S] tab.

Picture Setting		Quit
H1	H2	S
Echo Average	:	2
Int Reject	:	0
Smooth Echo RNG	:	3
Smooth Echo CIR	:	1
A-Train Echo Average	:	2
A-Train Int Reject	:	0

4. Select [Int Reject] then push the left-click button.
5. Select ▲ or ▼ then push the left-click button to adjust the setting. The setting range is 0-3. (Strong: 3→1→2:Weak)
6. Select [Quit] on the setting box then push the left-click button to close the box.
7. Long-press the **MENU/ESC** key to close all menus.

### 4.10.4 Shift TX frequency

If the interference can not be suppressed by the interference rejector or change in TX interval, shift the Tx frequency with the [Frequency] menu.

1. Press the **MENU/ESC** key to show the main menu.
2. Select [TX/RX Setting] then push the left-click button.
3. Press the **H/V/S** key to select the [S] tab.
4. Select [Frequency] then push the left-click button.

Frequency		Quit
Freq Shift1	:	0
Freq Shift2	:	-65
Freq/Bearing Set	:	0°

5. Select [Freq Shift1] then push the left-click button.
6. Select ▲ or ▼ then push the left-click button to adjust the setting from the dialog box. The setting range is -65 to 65.
7. Select [Quit] on the setting box then push the left-click button to close the box.

## 4. SLANT MODE

8. Long-press the **MENU/ESC** key to close all menus.

**Note 1:** In some cases the frequency can not be changed because of operating bandwidth. In this case the frequency setting is grayed.

**Note 2:** The setting for [Freq Shift2] is valid when [Sidelobe Sup.A] is set between -3 and -1. Set [Freq Shift1] well apart from [Freq Shift2] to better suppress sidelobes.

### 4.10.5 Noise limiter

Weak, unwanted reflections, colored light-blue or green, are caused by dirty water, plankton layers, or ship's noise. The noise limiter can reduce the effects of these unwanted reflections. Raising the setting causes unwanted reflections to be displayed in colors of blue to background color.

1. Press the **MENU/ESC** key to show the main menu.
2. Select [Display Setting] then push the left-click button.
3. Press the **H/V/S** key to select the [S] tab.

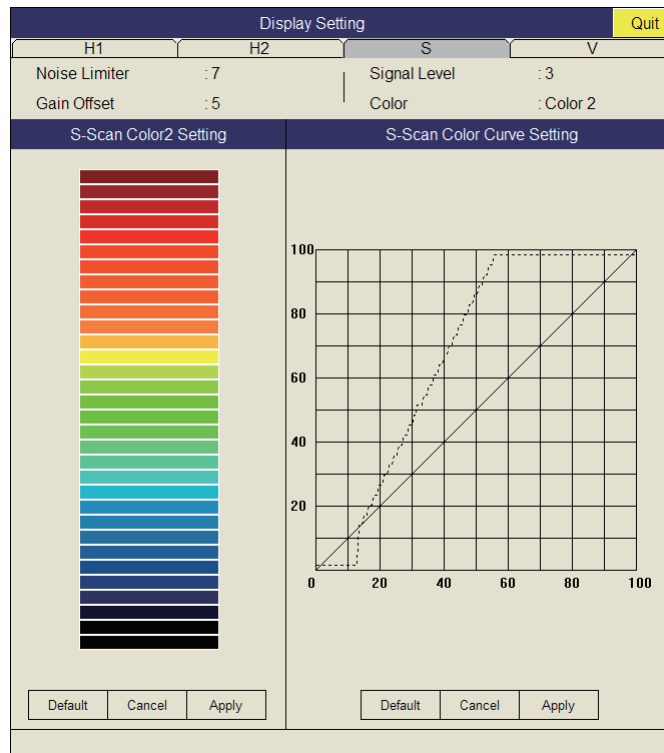

4. Select [Noise Limiter] then push the left-click button.
5. Select ▲ or ▼ then push the left-click button to adjust the setting. The setting range is 0 to 15.
6. Select [Quit] on the setting box then push the left-click button to close the box.
7. Long-press the **MENU/ESC** key to close all menus.

### 4.10.6 Reverberation

You may choose the length of reverberation for the echo signal, with [Reverberation] in the [TX/RX Setting] menu ([S] tab). The larger the value, the lower the reverberation effect, which makes it easier to see the echo signal. The setting range is 0-3.



### 4.10.7 Echo average

When using the Auto Train function, [Auto Train Afterglow] on the [Picture Setting] menu ([S] tab) adjusts echo afterglow - the amount of time an echo signal remains on the screen.

When not using the Auto Train function, [Echo Average] on the [Picture Setting] menu ([S]tab) adjusts echo afterglow.

This feature can be useful for watching echo movement. The setting range is 0-7.

**Setting between 1 and 3:** Echoes are gradually displayed and afterglow remains on the screen longer as the setting is increased.

**Setting between 4 and 7:** Echoes are quickly displayed and afterglow remains on the screen longer as the setting is increased.

### 4.10.8 How to suppress sidelobes

False echoes produced by sidelobes may appear on the display depending on the distribution pattern of a school of fish and the positional relationship between it and a marine object (reef, etc.) and wake reverberation. To reduce these sidelobes, use [Sidelobe Sup.] on the [TX/RX Setting] menu ([S] tab).

Sidelobe Sup.		Quit
Sidelobe Sup.A	: 3	
Sidelobe Sup.B	: 2	
Sidelobe Dir1	: 60°	
Sidelobe Dir2	: 120°	

For normal suppression, use [Sidelobe Sup.A]. The setting range is -3 to 4 and 0 is the default setting. The higher the value the greater the suppression. A minus value (-3 to -1) provides increased suppression.

**Note:** When the setting for [Sidelobe Sup.A] is a negative value, [TX/RX Mode] is automatically selected to [Alternative]. See "Display Setting Menu" on page 7-3 for details. For greater sidelobe suppression, use [Sidelobe Sup.B]. For details see page 2-19.

## 4.11 How to Adjust Beam Width

The width of the horizontal beam on the S-display can be adjusted from the [Beam Width] menu.

1. Press the **MENU/ESC** key to show the main menu.
2. Select [TX/RX Setting] then push the left-click button.
3. Press the **H/V/S** key to select the [S] tab.
4. Select [Beam Width] then push the left-click button.
5. Select an item then push the left-click button.  
Adjust the item as appropriate, referring to the description on the following page.

Beam Width		Quit
Beam Control	: Manual	
TX Beam Width	: 0	
Hor. RX Beam Wid	: 3	
Ver. RX Beam Wid	: 0	
RX Beam Control	: 0	

**Description of Beam Width menu**

**Beam Control:** Control the beamwidth according to option selected. Manual: Select this item to enable adjustment of the other items in this menu. Range: The beamwidth is automatically controlled with the range setting. Tilt: The beamwidth is automatically widened as tilt goes deep. This is convenient for keeping a watch on fish that ascend and descend.

**TX Beam Width\*:** Increase the value to display close-range echoes clearly.

**Hor. RX Beam Width\*:** Increase the value to improve horizontal resolution.

**Ver. RX Beam Width\*:** Increase the value to improve vertical resolution to distinguish fish echoes from bottom echoes.

**RX Beam Control:** Increase the value to improve horizontal resolution.

**Note:** When [RX Beam Control] is set to 1 - 3 and [Sidelobe Sup.B] is set to other than 0, [TX/RX Mode] is automatically selected to [Alternative]. See "Display Setting Menu" on page 7-3.

\*: Available only when [Beam Control] is set to [Manual].

6. Select [Quit] on the setting box then push the left-click button to close the box.
7. Long-press the **MENU/ESC** key to close all menus.

## 4.12 How to Track a School of Fish

The target lock function automatically tracks a school of fish so you will not lose sight of it on the display. Two types of target lock are available: position tracking and tracking of school of fish. Select one from the menu as shown in the procedure that follows. The default setting is tracking of school of fish. Speed and bearing data are required. The FSV-85 MARK-2 cannot track a school of fish if the level of the echo is too weak.

### 4.12.1 How to select the target lock mode

1. Press the **MENU/ESC** key to show the main menu.
2. Select [Others] then push the left-click button.
3. Select [Initial Setting] then push the left-click button.
4. Select [Changeable] then push the left-click button.
5. Select [Target Lock] then push the left-click button.

Target Lock		Quit
Tracking Method	: Fish	
Tilt Interlock	: Tilt&Range	
Mark Interlock	: Estimate Mark	
Tracking Data	: H & V	
Threshold	: 16	
Bottom Threshold	: 3	
Target Speed Limit	: 5kn	
Smoothing	: 0.5	
Target SPD Update	: 60Sec	
Target Lock Window	: Small	
Dimension Setup	: 25t/1000m <sup>2</sup>	
Volume Setup	: 25t/1000m <sup>3</sup>	

6. Select [Tracking Method] then push the left-click button.
7. Select [Target Mark] or [Fish] then push the left-click button.
8. Select [Quit] on the setting box then push the left-click button to close the box.
9. Long-press the **MENU/ESC** key to close all menus.

## 4.12.2 Fish mode

The automatic echo target lock function automatically tracks the operator-selected school of fish. When [Tilt Interlock] on the [Target Lock] menu (previous page) is set to [Tilt & Range], and the tracked school of fish goes out of the zone in the range direction, the range and tilt are automatically controlled according to the position of the school of fish.

1. Select [Fish] in the procedure in subsection 4.12.1.
2. On the slant display, use the trackball to select the school of fish to track.
3. Press the **TARGET LOCK** key.

The target lock mark (red) is put on the fish school echo. The target lock mark changes to white, with vector, when the school of fish is locked. The vector shows the speed and direction of movement of the school of fish. The tip of the vector is the estimated position of the school of fish when the vector time elapses. The target lock mark also appears on the vertical display, however the vector is not shown.

If the target is lost, the target lock mark changes to red color and the tracking mode changes to position mode (see next section) at that position. When the sonar detects and tracks the target again, the Fish mode is restored.

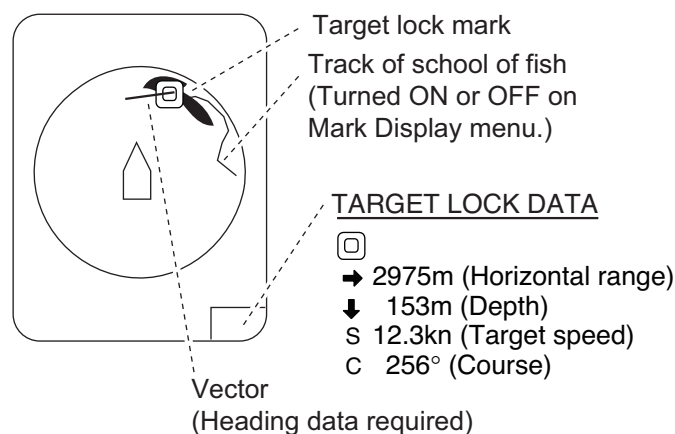

4. To disable the target lock, press the **TARGET LOCK** key.
 

**Note:** Target lock may be disengaged if:

  - The range control is operated.
  - The V1/S or V2 key is pressed while a locked target is displayed.

### 4.12.3 Target mark mode

This mode tracks a stationary position (such as a reef) using position data fed from a navigator.

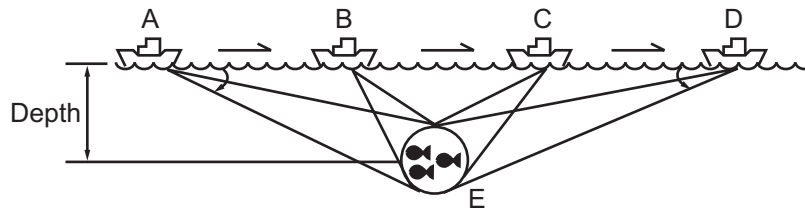

1. Select [Target Mark] in the procedure in section 4.12.1.
2. On the slant display, use the trackball to select the location to track.
3. Press the **TARGET LOCK** key.  
Tilt, range and vertical bearing are automatically adjusted to track the location. Using the figure above as an example, the target lock mark is placed on location E. Then, the equipment remembers the location of E and automatically changes the tilt angle as the ship moves from position A through D. As long as the school of fish E is stationary its echo is kept displayed on the screen.
4. To disable the target lock, press the **TARGET LOCK** key.

### 4.12.4 Target lock menu description

Target lock functions not previously mentioned are described below.

<b>Tilt Interlock</b>	Provides automatic change of tilt angle and range or tilt angle in target lock. Setting range: [OFF] (no automatic change), [Tilt ] (tilt angle), [Tilt & Range] (tilt angle and range)
<b>Mark Inter-lock</b>	Turns numeric/graphic data displays On/Off in target lock. [OFF] turns off both the estimate mark 1, 2 histogram and data display. [Estimate Mark] enables the estimate mark 1, 2 histogram. [Est & Fish Info] enables the both the estimate mark 1, 2 histogram and data display.
<b>Tracking Data</b>	During the slant mode, H/S display is adopted for all functions.
<b>Threshold</b>	Selects the minimum signal level to use in target lock tracking. The setting range is 1 to 30. Target lock tracks a target whose signal level is greater than set here.
<b>Bottom Threshold</b>	When a target is judged as a bottom echo, raise this setting to differentiate bottom from target. The setting range is 0 to 5.
<b>Target Speed Limit</b>	Sets maximum fish speed to track. The setting range is 1kn to 15kn.
<b>Smoothing</b>	Sets smoothing rate for fish speed data. The higher the figure, the smoother the position of the target lock target. Avoid oversmoothing, to prevent delay in tracking when own ship or target moves suddenly. The setting range is 0.0 to 1.0.
<b>Target SPD Update</b>	Sets the interval at which fish speed data is updated. The intervals are 15, 30, 45 and 60 seconds.
<b>Target Lock Window</b>	Selects the size of target lock detection area; normal, large, largest. (The area is not indicated on the screen.)
<b>Dimension Setup</b>	Sets dimension constant for calculation of weight (ton) of school of fish from the dimension of the school of fish.
<b>Volume Setup</b>	Sets volume constant for calculation of weight (ton) of school of fish volume.

## 4.13 How to Detect Schools of Fish Aurally

Sometimes you may be preoccupied with other tasks and unable to concentrate on watching the sonar picture. In such cases it would be a good choice to use the audio function. This function enables you to monitor echoes from schools of fish and bottom through the external speaker.

### 4.13.1 How to set the bearing

In the default setting, the audio function is on and the audio sector is 30°.

1. Operate the trackball to place the cursor on the direction you want to monitor through the speaker.
2. Press the **R/B AUDIO** key.

The audio bearing mark appears on the bearing selected, in a 30°, 60°, 90°, 180° or 330° sector centering the audio bearing mark. Echoes are monitored through the speaker.

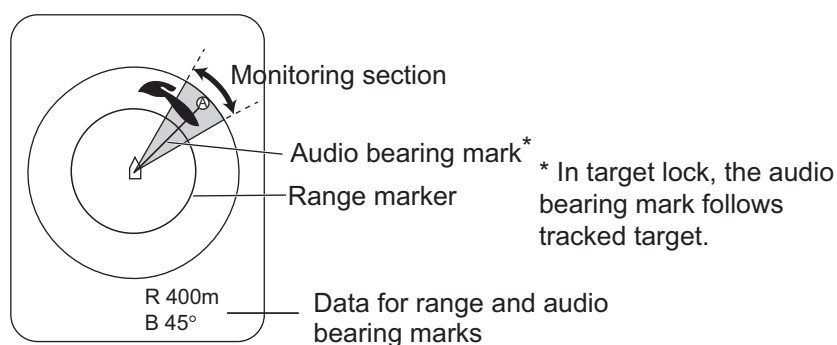

**Note:** To erase the range mark and the data at the bottom of the screen, put the cursor near own ship mark and press the **R/B AUDIO** key. Note that the audio bearing is erased when [Audio] on the [Alarm & Audio] menu is turned off.

### 4.13.2 How to select the audio sector

Select the audio sector as follows. Note that you cannot watch this sequence on the display.

1. Press the **MENU/ESC** key to show the main menus.
2. Select [Others] then push the left-click button.
3. Select [Alarm & Audio] then push the left-click button.

Alarm & Audio		Quit
Fish Alarm	: OFF	
Alarm Level	: 16	
Alarm Zone...		
Ship SPD Alarm	: ON	
Audio	: ON	
Audio Volume		
Audio Sector	: 30°	
Reverberation	: 0	

## 4. SLANT MODE

4. Select [Audio Sector] then push the left-click button.

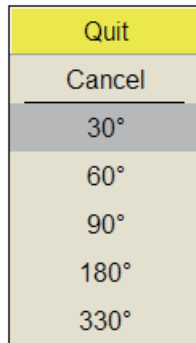

5. Select the desired sector then push the left-click button.
6. Select [Quit] on the setting box then push the left-click button.
7. Long-press the **MENU/ESC** key to close all menus.

### 4.13.3 Reverberation for audio signal

You may choose the length of reverberation of the audio signal, with [Reverberation] on the [Alarm & Audio] menu. The larger the value the longer the reverberation, which makes it easier to hear the audio signal. The setting range is 0-9 and the default setting is 0.

## 4.14 Fish Alarm

The fish alarm sounds the buzzer when a fish echo above a preset strength enters the operator-set alarm zone.

1. Press the **MENU/ESC** key to show the main menu.
2. Select [Others] then push the left-click button.
3. Select [Alarm & Audio] then push the left-click button.
4. Select [Fish Alarm] then push the left-click button.
5. Select [ON] then push the left-click button.
6. Select [Quit] on the setting box then push the left-click button.
7. Select [Alarm Zone] then push the left-click button.
8. Operate the trackball to place the cursor on the starting point of the alarm zone.
9. Push the left-click button.

10. Operate the trackball to select the ending point. The display paints a fan-shaped alarm zone.

The alarm range appears on the display as shown below.

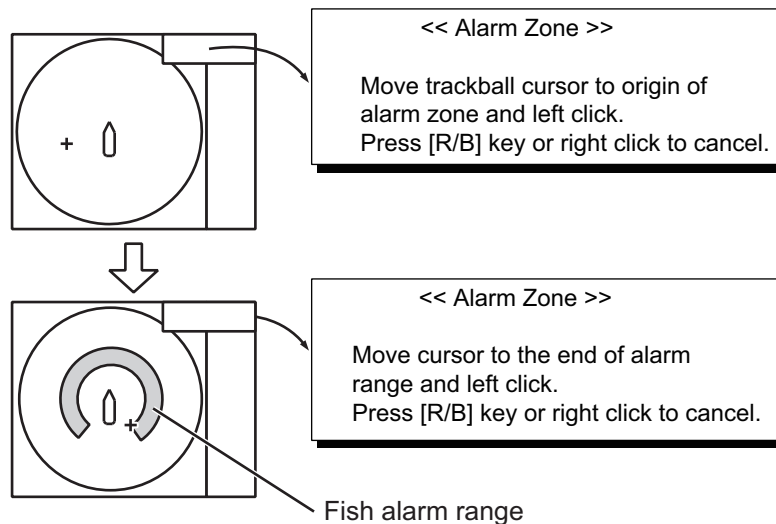

11. Push the left-click button.

12. Long-press the **MENU/ESC** key to close all menus.

When a fish echo enters the alarm area the buzzer sounds.

**Note 1:** There must be at least three degrees difference between the starting and ending points to get a fan-shaped alarm zone as shown in (a) and (b) below. Otherwise, the unit paints a 360-degree alarm zone as in (c) where there is less than 3 degrees between the starting and ending points.

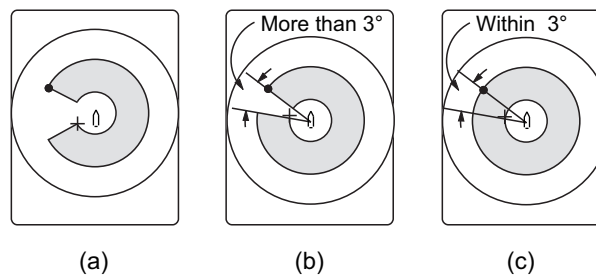

**Note 2:** The echo strength which triggers the alarm can be set with [ALARM LEVEL] on the [Alarm & Audio] menu. The setting range is 0-30. This value corresponds with the 32-echo colors.

To disable the alarm, select [OFF] in the procedure on the previous page.

## 4.15 How to Relocate a School of Fish

The offcenter features functions to relocate a school of fish.

### 4.15.1 Manual offcenter

1. Operate the trackball to place the cursor on the position where you want to relocate the own ship mark.
2. Press the **OFF CENTER** key.

## 4. SLANT MODE

3. To move the own ship mark back to the screen center, press the key again.

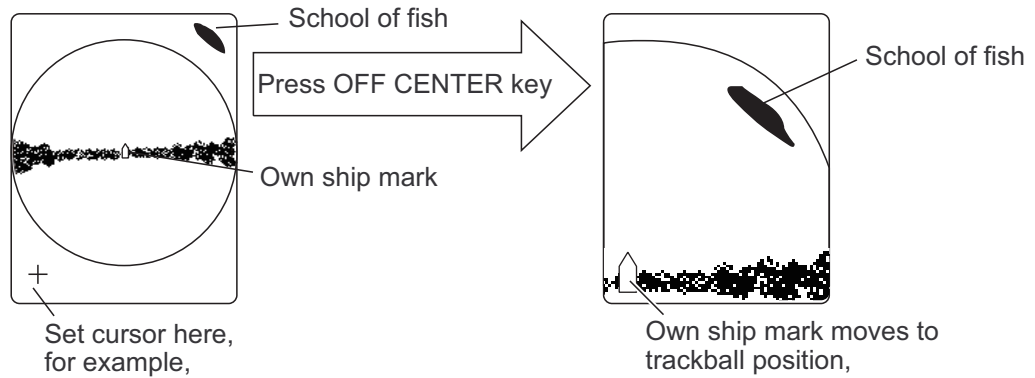

**Note:** You can also move the display by long-pressing the left-click button. To restore the normal display, long-press the right-click button.

### 4.15.2 Automatic offcenter

The slant mode in the slant mode combination display (landscape) can be automatically off centered when the train is changed while using auto train or target lock or the user changes the train angle manually. This is useful to maintain effective range at 1.0. To activate this feature it is necessary to activate automatic offcenter from the menu.

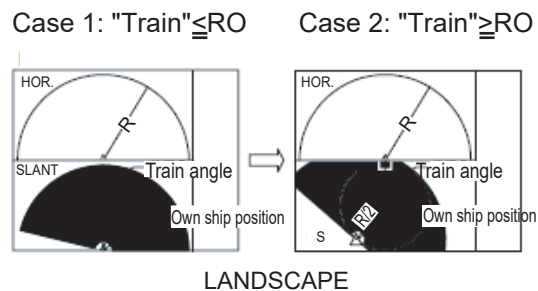

\* Numeric/graphic display area

Train angle: Angle in automatic training, set with the **V1/S** or **V2** key

R0: Train angle (30°, 45°, 60°) set on menu.

Automatic offcentering is available regardless whether the train angle setting value is the same or larger than actual train angle.

1. Open the [Others] menu from the main menu.
2. Select [Display Setting] then push the left-click button.
3. Select [S Auto Off Cent] then push the left-click button. This function is only operative when the slant combination display is active in horizontal split at the sub display mode.
4. Select an option then push the left-click button.
5. Select [Quit] on the setting window then push the left-click button.
6. Long-press the **MENU/ESC** key to close all menus.



## 4.16 How to Compare Concentration of School of Fish

### 4.16.1 How to compare with the fish estimate mark

You can get an estimate of the volume of two schools of fish by using the two ESTIMATE keys as follows:

1. Operate the trackball to place the cursor on a school of fish, and then press the **ESTIMATE 1** key.  
The estimate mark appears on the school of fish. Relative volume is shown by a figure between 0 and 100, below the estimate mark. When the area inside the mark is filled in reddish brown, volume figure is said to be 100. When the estimate mark is entered, a graph is shown at the histogram on the numeric/graphic data display.
2. Operate the trackball to place the cursor on a school of fish, and then press the **ESTIMATE 2** key.  
Compare estimate figures for each school of fish by observing estimate mark data and the fish histogram.
3. To turn off the estimate marks press their respective keys.

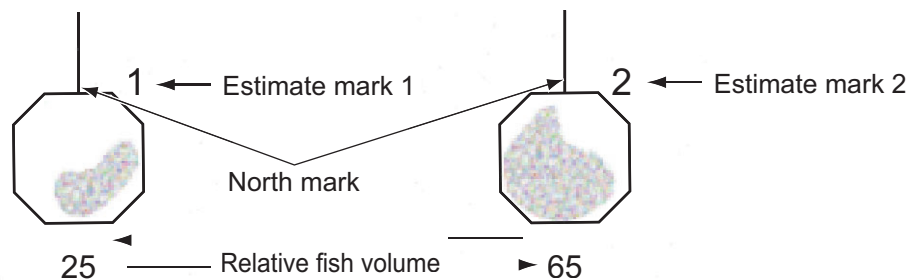

**Note:** The fish school mark and event mark 1 can be entered with the fish estimate mark. For details, contact your dealer.

### 4.16.2 How to compare with the circle cursor

You can get an estimate of the volume of two schools of fish with the diameter of the school of fish as follows:

1. Push the scrollwheel to show the circle cursor.  
The cross cursor changes to the circle cursor (dotted line).

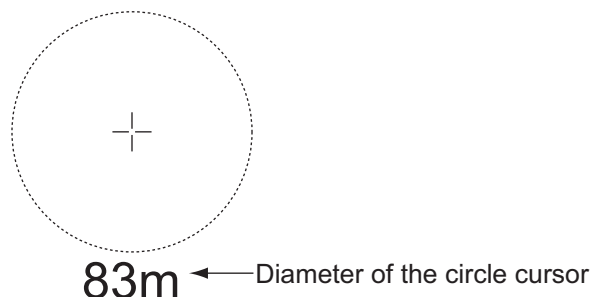

2. Place the circle cursor on the school of fish.

#### 4. SLANT MODE

3. Rotate the wheel to adjust the size of the circle cursor.  
Set the school of fish in the circle cursor to estimate correctly. The diameter of the circle cursor is displayed below the circle cursor.
4. Place the circle cursor on another school of fish to estimate the volume.  
You can compare the volume of two schools of fish with the diameter of the school of fish.
5. Push the right-click to quit the measurement.  
The circle cursor is changed to the normal cursor.

**Note 1:** Select the event mark 1, event mark 2, fish mark, target lock mark, estimate mark 1, or estimate mark 2 from the [Select Mark] window. Push the left-click to enter the mark.

**Note 2:** Set the diameter of the circle cursor in [Circle Cursor Diameter] of the [Display Setting] menu (default: 200 m). See section 7.3.

## 4.17 How to Measure the Speed of a School of Fish

To ensure a good haul, it is important to estimate the direction and speed of the school of fish before shooting the net. You can do this with the **FISH** key. With tidal current data and fish speed data, you can determine the timing of the net shooting more efficiently. Fish mark has a two types (□ fish mark 1/◇ fish mark 2) and a maximum of 20 fish marks can be entered per mark type. This function requires speed and heading data.

### 4.17.1 How to measure the speed of a school of fish

1. Place the cursor on the center of a school of fish then press the **FISH** key or push the left button. The latest fish mark (□ or ◇) appears on the school of fish.
2. Wait until the target fish moves a reasonable distance from the latest fish mark.
3. Place the cursor on the same school of fish selected in step 1 then press the **FISH** key.

The latest fish mark (□ or ◇) appears on the target, the 2nd latest fish mark (□ or ◇) appears on the location selected at step 1 and any earlier fish marks are shown with an X. The distance between the two fish marks and speed, course, and bearing of the school of fish appear at the bottom right-hand corner of the slant mode display area.

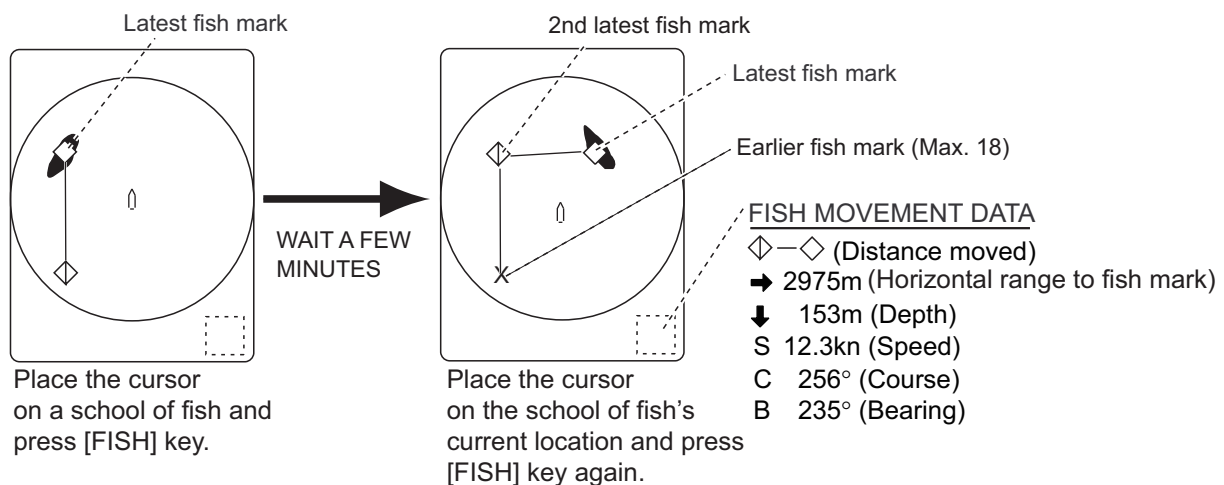

**Note 1:** The time and distance between each press of the **FISH** key should be as long as possible to increase accuracy of measurement. For best results, repeat the procedure two or three times.

**Note 2:** Each time the **FISH** key is pressed the latest fish mark and ship's speed mark change in the sequence shown below. A maximum of 20 fish marks can be entered. When you enter more than 20, the earliest fish mark is erased.

**Fish Mark 1**

[FISH] key pressed once  
 // // twice  
 // // three times  
 // // four times

This data is the latest fish mark data.

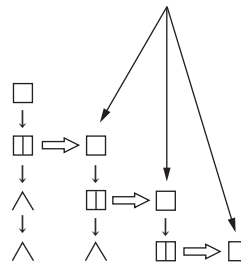

**Fish Mark 2**

[FISH] key pressed once  
 // // twice  
 // // three times  
 // // four times

This data is the latest fish mark data.

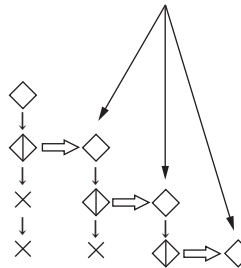

**4.17.2 How to delete fish marks**

Fish marks can be deleted individually with the **DELETE MARK** key or by earliest entry from the menu.

**How to delete fish marks with the DELETE MARK key**

1. Use the trackball to place the cursor on the fish mark you want to erase. The color of the fish mark changes from white to red when the fish mark is correctly selected.
2. Press the **DELETE MARK** key to delete the fish mark.

**How to delete fish marks from the menu**

Use the trackball to place the cursor on the fish mark you want to erase. The color of the fish mark changes from white to red when the fish mark is correctly selected. Press the **DELETE MARK** key to delete the fish mark.

1. Push the right-click button on the numeric/graphic data display to show the pop-up menu.
2. Click [Erase Marks].

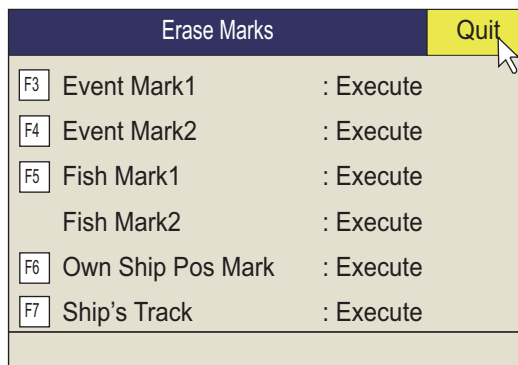

3. Click [Fish Mark1] or [Fish Mark2]. Each click deletes the earliest fish mark.
4. Long-press the **MENU/ESC** key to close all menus.

**Note:** The default function of the 5/F5 key (for fish mark 1) deletes the earliest fish mark.

## 4.18 Event Mark

The event mark is useful for finding the horizontal range, depth and bearing to a location some distance from current position. There are two types of the event marks: event mark 1 and event mark 2. Each marks can be inscribed on the slant mode display up to 20 marks. This function requires speed and heading data.

When the event mark is entered, latest event mark is displayed. Each time an event mark is entered the latest event mark appears at the cursor position and all other event marks are shown by mark and numbered in sequential order. When the memory capacity for event marks is reached the earliest event mark is automatically erased to make room for the latest.

### 4.18.1 How to enter an event mark

1. Set the cursor where you want to place an event mark.
2. Press the **EVENT** key. The horizontal range, depth and bearing to the event mark appear at the bottom left corner of the slant mode display area.  
The event mark 1 can be entered by pushing the right-click button.

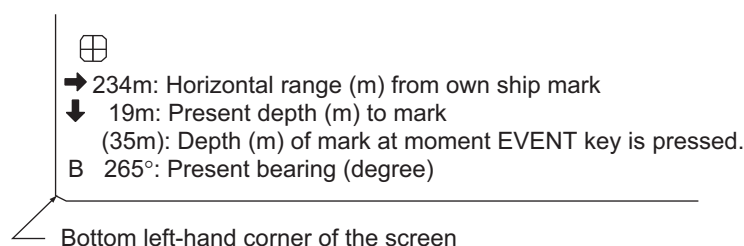

*Ex. Indications when the **EVENT** ⊕ key is pressed*

With speed and heading data the mark follows own ship movements. In the True Motion mode, the event mark is stationary. When the tilt angle is changed mark position changes with slant range. Note however that the mark position does not change when automatic tilt is active; the tilt center angle is used to position the mark.

Plotting an event mark on the display is equivalent to dropping a buoy with an anchoring chain that extends from surface to bottom. The buoy is fixed at its geographical location, but the marker on the display moves to a point where the present beam plane intersects the anchor chain of the buoy as the ship moves or the tilt angle is changed. This can be said about marks as well such as fish mark and cursor.

## 4. SLANT MODE

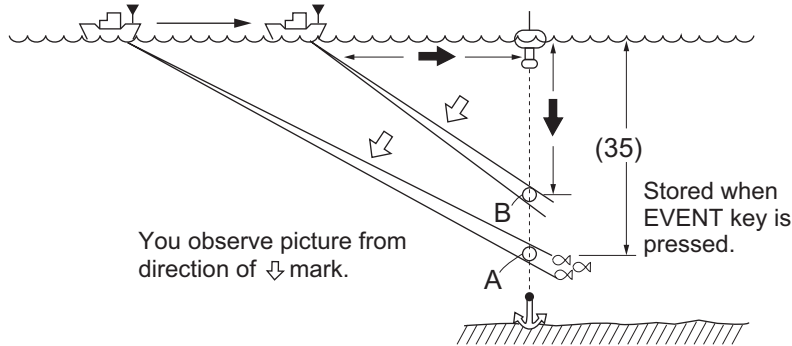

### 4.18.2 How to erase an event mark

Event marks can be deleted individually with the **DELETE MARK** key or by earliest entry from the menu.

#### Delete an event mark with MARK DELETE key

1. Use the trackball to place the cursor on the event mark you want to erase. The color of the mark changes from white to red when the mark is correctly selected.
2. Press the **DELETE MARK** key to delete the mark.

#### Delete an event mark from the menu

1. Push the right-click button on the numeric/graphic data display to show the pop-up menu.
2. Select [Erase Marks] then push the left-click button.
3. Select [Event Mark1 (2)] then push the left-click button. Push the left-click button again to delete the earliest mark.
4. Long-press the **MENU/ESC** key to close all menus.

**Note:** The default function of the **3/F3** (for event mark 1) and **4/F4** (for event mark 2) keys delete the oldest event mark or own ship mark.

## 4.19 Net Course Mark

Before shooting the net, decide the shoot timing considering tide direction, distance to the school of fish and moving direction of the school of fish. Use the net course mark as a guide to decide the timing. This function requires speed and heading data.

#### How to enter the net course mark

1. Press the **MENU/ESC** key to show the main menu.
2. Select [Others] then push the left-click button.
3. Select [Display Setting] then push the left-click button.

4. Select [Net Course Mark] then push the left-click button. Instructions for how to set the net course mark appear on the display.

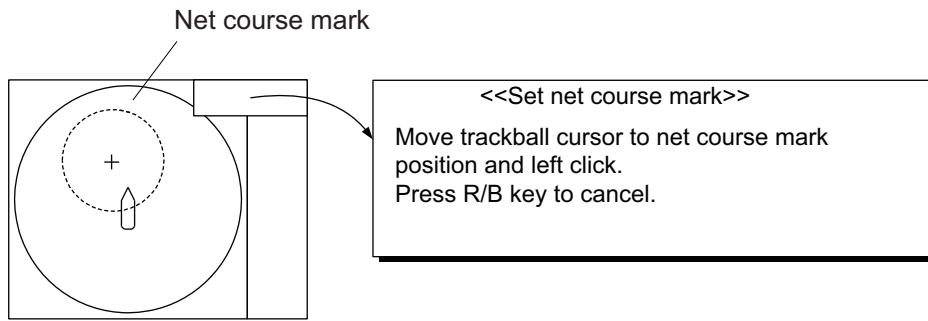

5. Use the trackball to position the net course mark, which is shown by a dashed circle.
6. Push the left-click button to set, and the dashed circle changes to a solid one.
7. Long-press the **MENU/ESC** key to close all menus.

**Note 1:** To delete the net course mark select [Delete] at step 4.

**Note 2:** The default function of the 0/F10 key deletes the oldest net course mark.

## 4.20 Net Data

With net sonde connection you can observe net data after the throwing of the net. Press the **SHOOT** key just upon throwing the net into the water to display the net shoot data and net depth data. To erase the data, press the key again.

**Note:** To enable this feature, set Event Key to Event in the Mark Display menu.

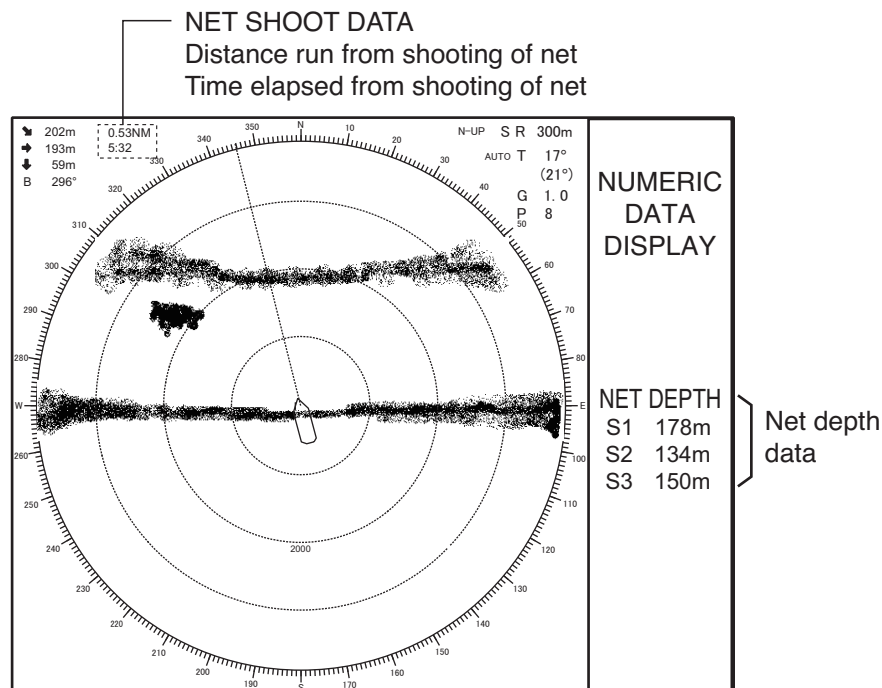

## 4.21 Menu Items Descriptions

This section presents menu items which have been not mentioned previously.

### Gain Setting menu

Gain Setting		Quit	
H1	H2	S	V
TVG-Near		: 5	
TVG-Medium		: 5	
TVG-Far		: 2	
TVG Distance...			
Sel. TVG Curve		: TVG 3	
AGC		: 0	
Near AGC...			
2nd AGC...			
Absorption Coeff.		: 26.5dB	
Gain Control		: Wide	

**Gain Control:** If the amount of gain change affected with the **GAIN** control on the front panel is too low, change the setting to [Wide], to double the range of the control.

### Display Setting menu

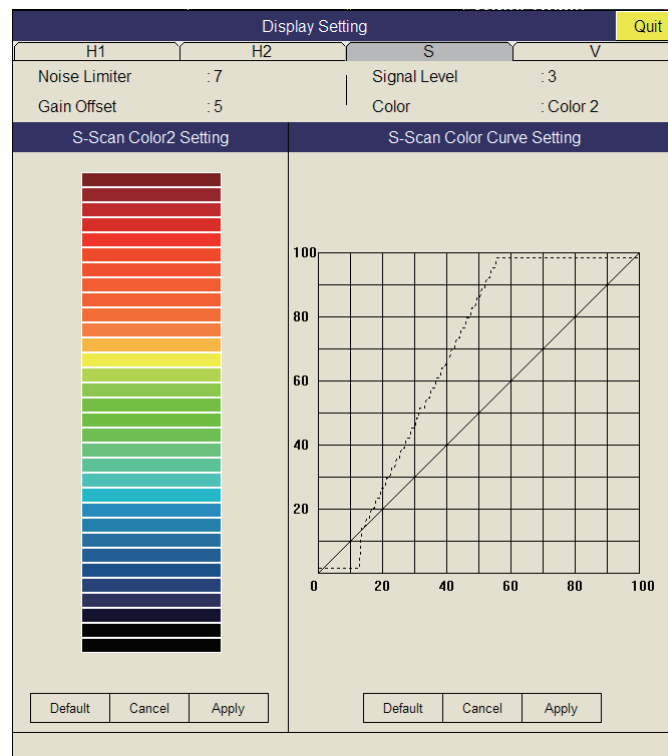

**Gain Offset:** Adjusts gain level. If the **GAIN** control on the front panel does not provide satisfactory gain adjustment, enter an offset here. The setting range is -24 to 12.

**Signal Level:** Contaminated water or reflections from plankton may be painted on the screen in green or light-blue. These echoes may be erased in order of strength. The setting range is 0-15; 0 corresponds to the weakest color.



**Color:** Select color arrangement to use.

**S-Scan Color1 (2 to 4) Setting:** Customizes colors.

**S-Scan Color Curve Setting:** Adjusts reflected echo strength versus echo color level for currently selected color response number.

### Picture Setting menu

Picture Setting			Quit
H1	H2	S	V
Echo Average		: 2	
Int Reject		: 0	
Smooth Echo RNG		: 3	
Smooth Echo CIR		: 1	
A-Train Echo Average		: 2	
A-Train Int Reject		: 0	

**Smooth Echo RNG:** Selects echo smoothing level in the range direction. The setting range is 0-7. The higher the setting, the greater the smoothing.

**Smooth Echo CIR:** Selects echo smoothing level in the circular direction. The setting range is 0-5. The higher the setting, the greater the smoothing.

## 4.22 How to Interpret the Slant Display

### 4.22.1 Bottom echoes

When the tilt angle is set at 90 degrees with the sector center faced dead ahead, the pictures illustrated below will appear on the screen. The bottom echo is represented on the screen as a thick line which realistically shows the bottom contour. When the tilt angle is decreased, the bottom trace becomes wider and weaker. By observing bottom condition on the screen, you may prevent the net from being damaged by a reef or a shipwreck.

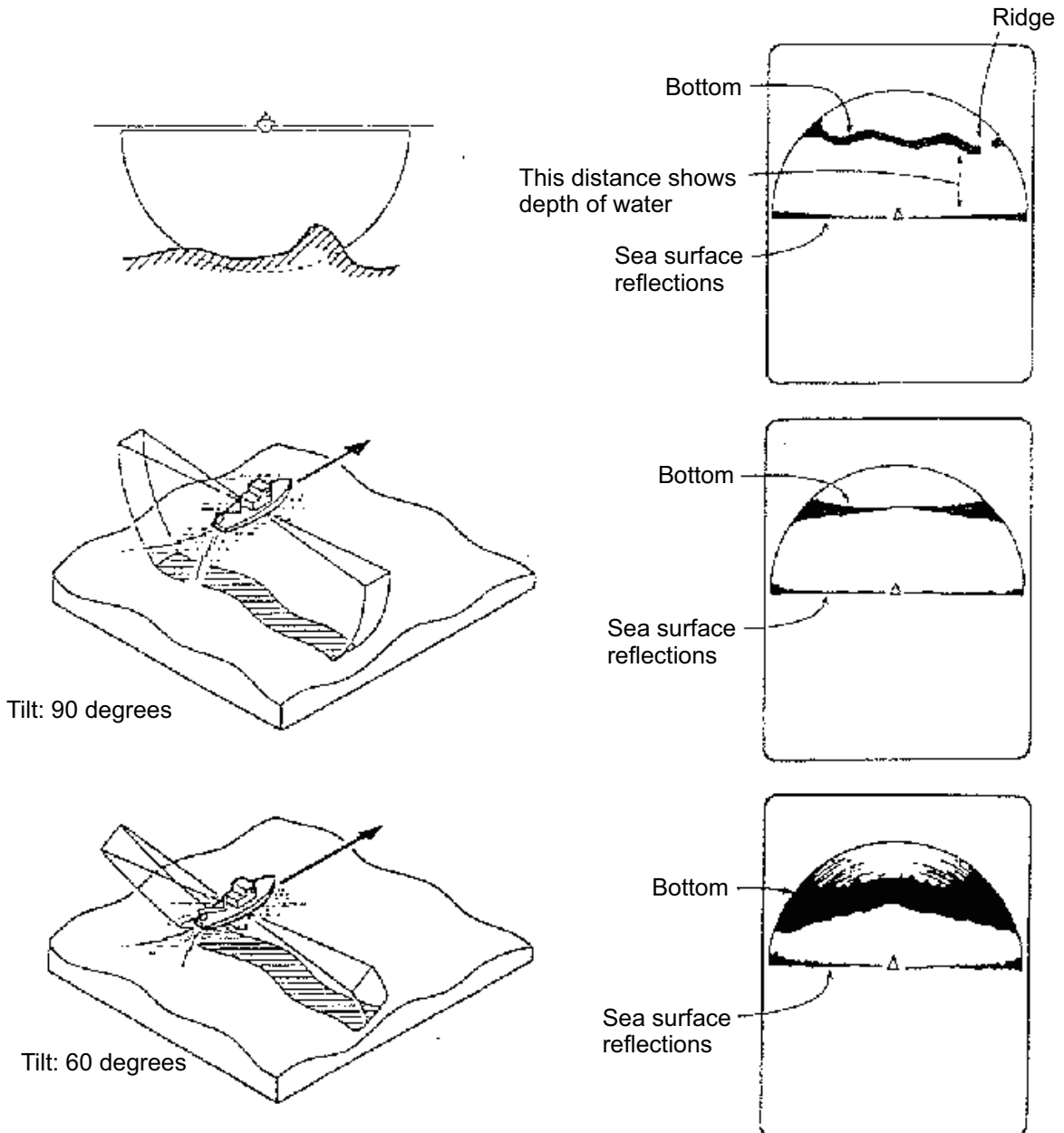

### 4.22.2 School of fish

A school of fish appears as a mass of echoes on the screen. The color of the mass shows the density of the fishes and the size of the mass how they are distributed. In the following figures, the same school of fish is observed with two different tilt angles. From the left figure, the operator can know the horizontal distribution of the school of fish and from the right figure the vertical distribution.

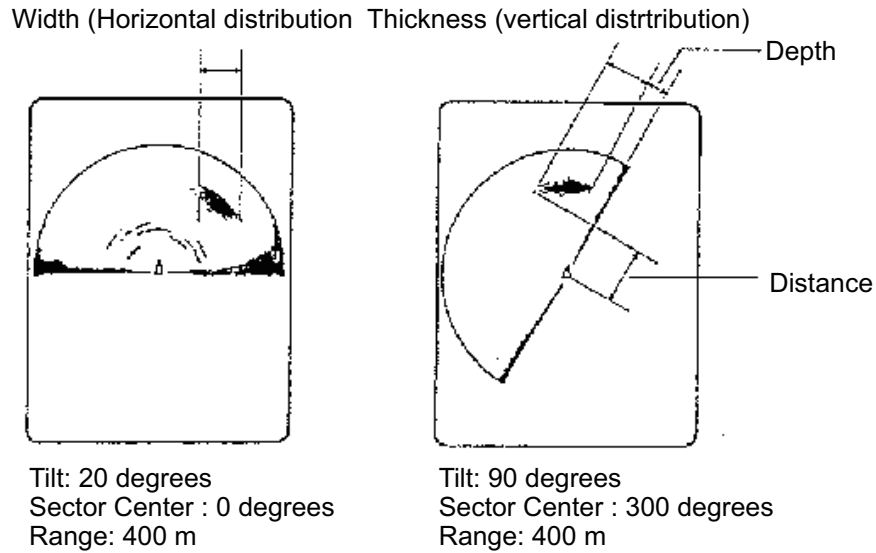

### School of fish on surface

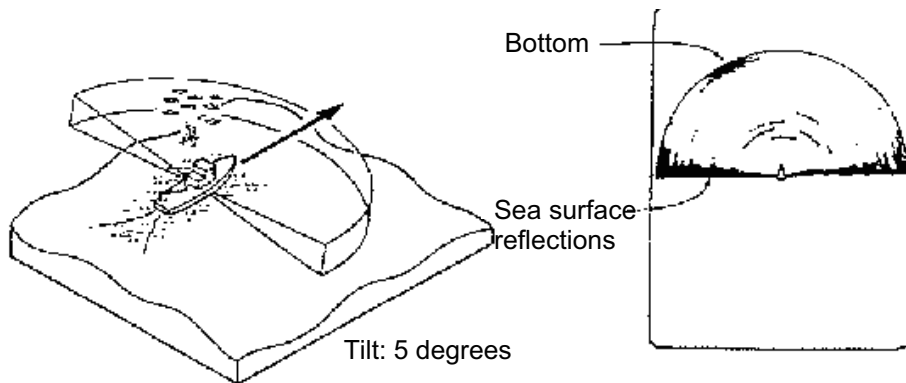

### School of fish on bottom

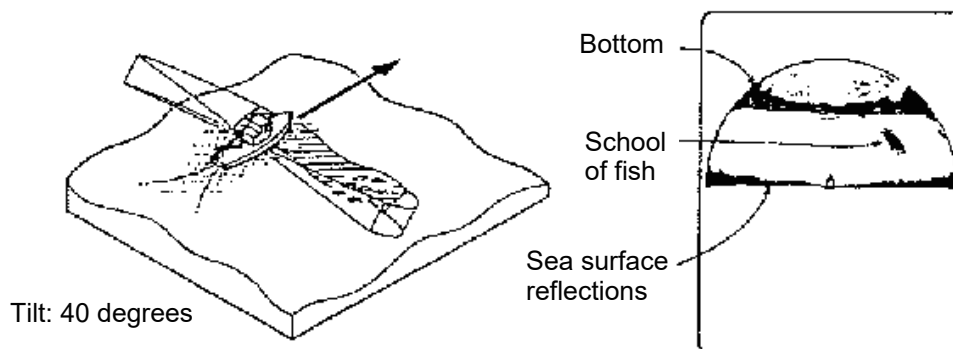

### 4.22.3 False echoes

#### Sea surface reflections

In the half-circle display, sea surface reflections appear as a thick line extending across the own ship mark regardless of tilt angle. When the sonar is used with a narrow tilt angle, the sea surface reflections cover an extended area as illustrated below.

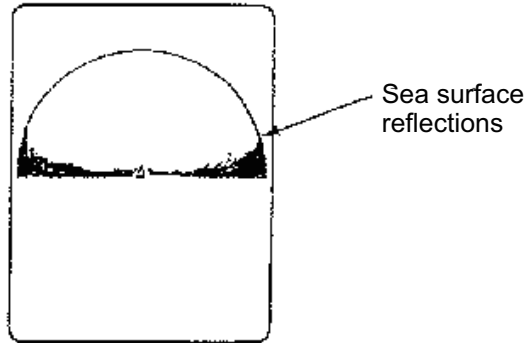

#### Wake

A wake produced by own ship or another ship can be a strong reflecting object when a narrow tilt angle is used. As the wake appears as a thick continuous line, it can be easily distinguished from a school of fish. A wake contains many air bubbles which attenuate ultrasonic energy, making it difficult to sound beyond the wake.

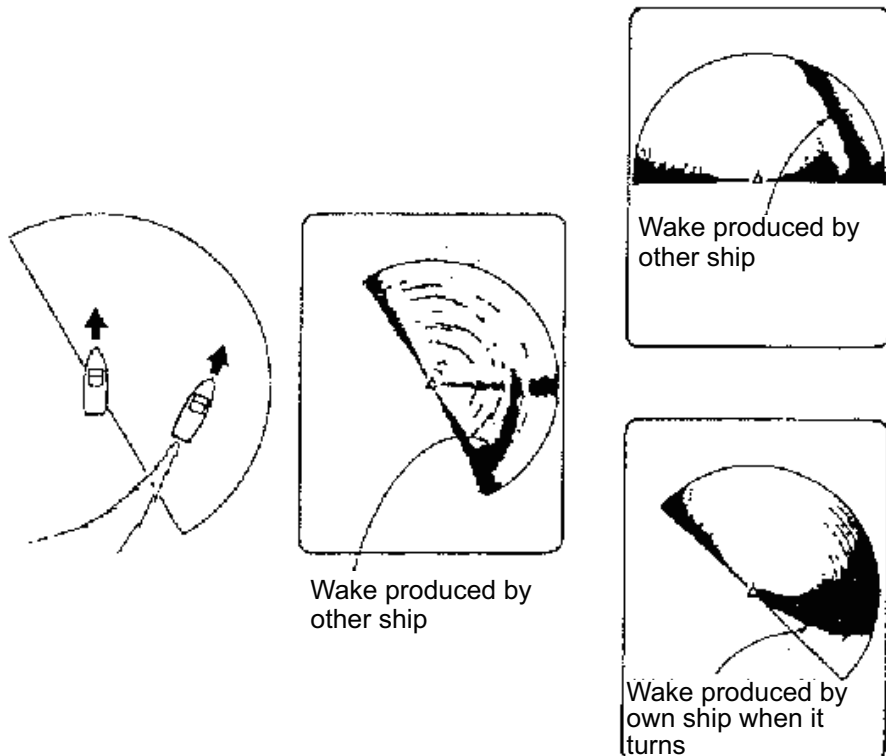

### False echo by sidelobe

An ultrasonic wave is emitted only in the direction set by the **TILT** control, however there are some emissions outside the main beam. These are called sidelobes. The energy of the sidelobe is fairly weak but when the water is comparatively shallow and the bottom is rocky and hard, strong signals are detected by the sidelobe. These are represented on the display as a false echo as shown below.

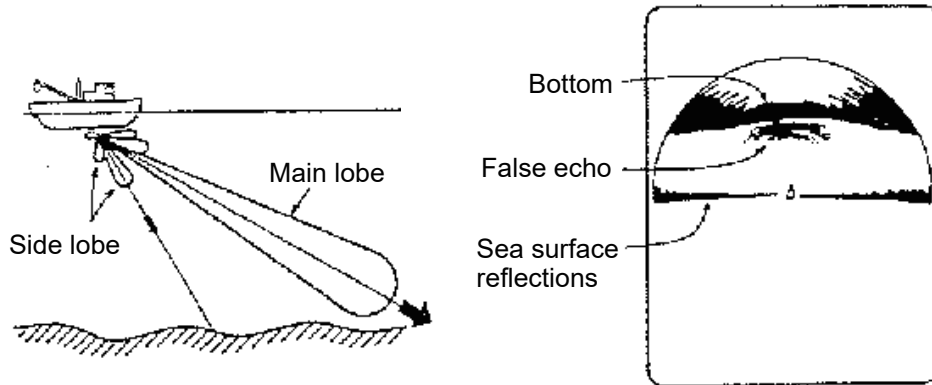

### Noise and interference

Interference from a sonar on another ship appears on the screen as shown in (A). (B) shows Interference from electrical equipment on board own ship. Noise from marine life appears on the display as shown in (C).

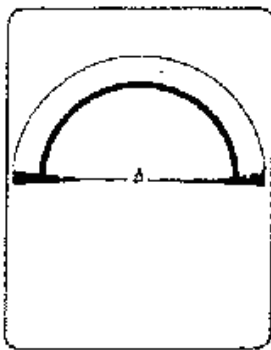

(A) Interference from other sonar

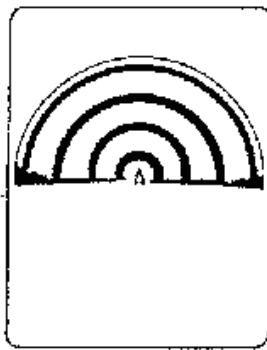

(B) Electrical interference

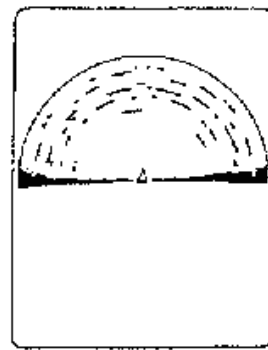

(C) Noise from marine life

#### 4. SLANT MODE

This page is intentionally left blank.

# 5. NUMERIC/GRAPHIC DATA DISPLAY

## 5.1 Numeric/Graphic Data Display

This display provides comprehensive numeric/graphic data and appears with the horizontal and vertical displays, at the right side of the display.

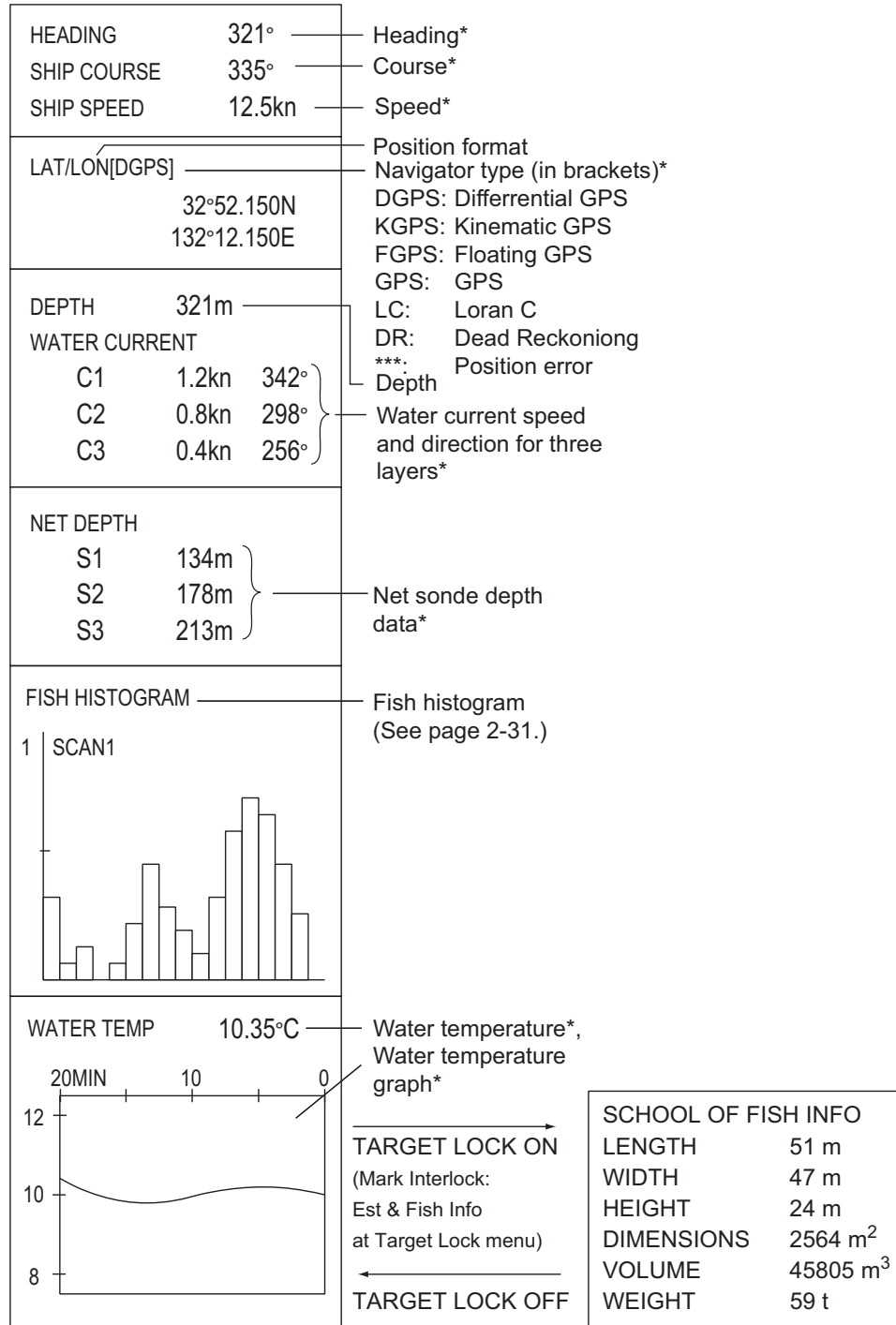

\* Requires appropriate sensor.

## 5.2 Numeric, Graphic Data Description

When a data is lost its last-entered value is shown in red. Data displays can be turned on or off through the [DATA DISPLAY] menu.

Numeric/ Graphic item	Description	Display range	Available formats	Where to change format
Heading	Shows heading input from heading sensor.	32 comp. pts, 0°-359° 0°-359°	32 comp. pts. 360° True 360° Rel 180° Rel	[Data Display] menu
Course	Shows ship course fed from numeric/graphic indication.	1°-179° P/S, 0°, 180°		
Speed	Shows ship speed fed from a Numeric/graphic indication.	0-40 kn <b>Note:</b> Fore-aft/port-stbd speed data (VBW) required.	Fixed at knots	
Position of the ship	Ship position in latitude and longitude. If position data is lost the last-entered position is shown in red.	Lat: 90°00.000S- 90°00.000N Lon: 179°59.999W- 179°59.999E, 180°00.00 0°00.000	Lat/Lon	
Position sensor	The position sensor type is displayed in brackets (“[ ]”). When the position sensor is not connected, the brackets are left blank.	DGPS, KGPS, FGPS, GPS, LC, DR, <b>***Note: “****”</b> is displayed when the positioning error occurs.	GPS Loran-C DR AUTO	System menu
Depth	Shows depth from transducer to bottom.	0-9999 m	Meters	
Current	Shows tide speed and direction for three layers or tide and speed for two layers against a reference layer fed from a current indication.	Cur. Speed: 0-9.9 kn Direction: 0°-359°	Direction shown as flow from or flow to	[Current Vec & Wind] menu
Net depth	Depth of net sonde transmitter. Shown only at shooting of net.	0-999 m	Depth of up to 3 pts can be displayed.	[Net Sonde Setting] menu



Numeric/ Graphic item	Description	Display range	Available formats	Where to change format
Fish histo- gram	Shows signal strength concentration of fish estimate mark inscribed on horizontal display, slant display	Two marks	On/Off on the [Mark Display]- [Histogram Disp.] menu	
Water temp.	Shows water temperature input from a temperature sensor.	-10.00°C to +40.00°C 14.00°F to 104.00°F	°C, °F	[Data Display] menu
Water temp. graph	Shows water temperature over time. Horizontal axis: time, Vertical axis: °C(°F)	Horizontal axis: Time 20 min./1h/6h/12h/24h, Vertical axis: Temp. 4°C, 8°F, fixed width, auto shift)	°C, °F	[Data Display] menu
Info on school of fish	Shows information about school of fish during target lock operation.	<b>Length:</b> Distance to school of fish in range direction <b>Width:</b> Distance to school of fish in bearing direction <b>Height:</b> Vertical distance <b>Dimensions:</b> Horizontal dimension of school of fish <b>Volume:</b> Estimated volume of school of fish <b>Weight:</b> Estimated tonnage of school of fish, calculated from dimension or volume above		

5. NUMERIC/GRAPHIC DATA DISPLAY

This page is intentionally left blank.

# 6. HOW TO CUSTOMIZE THE SONAR

## 6.1 User Menu

You may program 20 often-used menu items to the user menu area in the menu. The default user menu contains, for the horizontal display, pulse length, TX power, TVG near, TVG medium, TVG far, AGC, 2nd AGC, echo average, color and echo average.

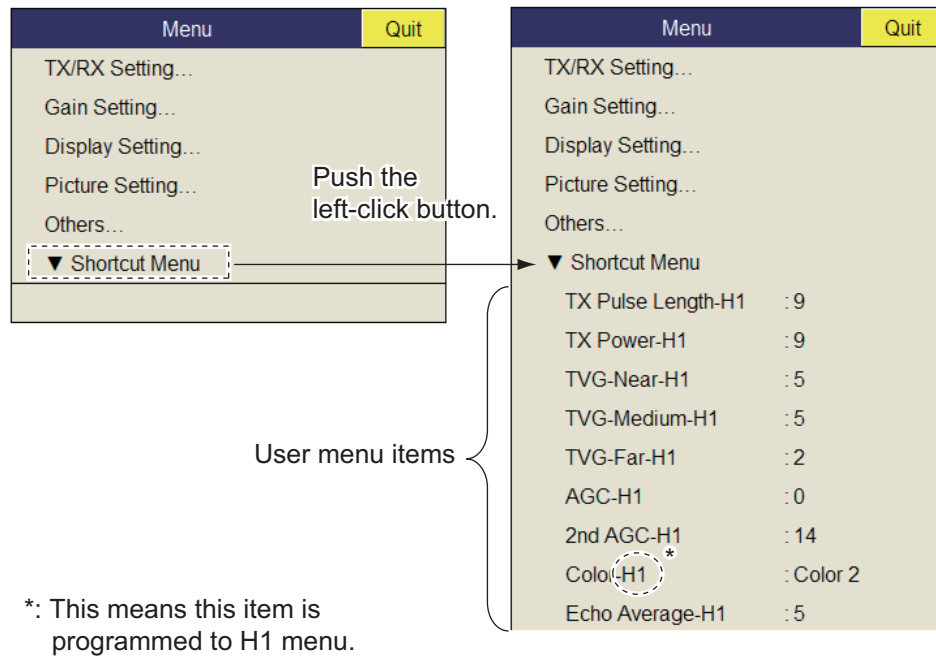

### 6.1.1 How to program the user menu

The procedure below shows you how to add the menu item [S Mode] (on the Wheel Setting menu) to the user menu. Some menu items cannot be programmed to the user menu. See the menu tree on page AP-1 to AP-5 for items which can be programmed.

1. Push the right-click button on the numeric/graphic data display to show the pop-up menu.
2. Select [Wheel Setting] then push the left-click button.

Wheel Setting		Quit
H Mode	: Tilt Angle	
S Mode	: Tilt Angle	
V Mode	: Bearing	
Wheel	: Reverse	

3. Select [S Mode] then push the left-click button more than one second. The message "User Menu Registration Selected item will be registered in main menu." appears.

## 6. HOW TO CUSTOMIZE THE SONAR

4. Select [Register] then push the left-click button.  
The selected item is registered, and shown at the bottom of the menu. The order of items in the [USER] menu can be changed by drag and drop.

**Note:** If 20 items are already registered to the user menu the following message appears. Delete unnecessary items from the user menu and then repeat this procedure to register different item. Press the **MENU/ESC** key to close this message.

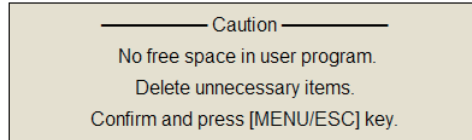

5. Long-press the **MENU/ESC** key to close all menus.

### 6.1.2 How to delete items from the user menu

To delete a menu item from the user menu which you do not require, do as follows.

1. Press the **MENU/ESC** key to open the main menu.
2. Select [▼ Shortcut Menu] then push the left-click button.
3. Select the item to delete then push the left-click button more than three seconds.  
The message "Delete Registration Selected item will be removed from main menu. Are you sure?" appears.
4. Select [Remove] then push the left-click button to delete.
5. Long-press the **MENU/ESC** key to close all menus.

## 6.2 Function Keys (1/F1-0/F10)

The function keys provide one-touch display of desired menu item or entire menu. The default function key settings are as below. Not all menu items and menus may be programmed to the function keys. See the menu tree on page AP-1 to AP-5 for items which may be programmed.

Function key	Default setting	Function
1/F1	Record Still Image	Save the still image
2/F2	Recall Still Image	Open the [Still Image] window
3/F3	Event Mark 1	Erase event mark 1
4/F4	Event Mark 1	Erase event mark 2
5/F5	Fish Mark 1	Erase fish mark 1
6/F6	Own Ship Pos Mark	Erase own ship position mark
7/F7	Ship's Track	Erase approx 10% of the ship's track
8/F8	Dimmer	Adjust panel dimmer
9/F9	Stabilization	Activate or deactivate the stabilization
0/F10	Net Course Mark	Enter or erase the net course mark

## 6.2.1 How to execute a program

1. Press desired function key to show the applicable dialog box.



*When the 8/F8 key is pressed*

2. Press the same function key again within five seconds to execute the function. The dialog box automatically disappears in five seconds. You can also close the dialog box manually by pressing any function key other than the one pressed at step 1.

**Note:** Functions registered to the function keys can be activated by using the software function keys which appear at the bottom of display.

## 6.2.2 How to program the function keys

You can change the default setting of a function key or register a timer function to a function key as shown below. Note that some menu items cannot be programmed to the function keys. See the menu tree on page AP-1 to AP-5 for items which can be programmed for function keys.

1. Press the **MENU/ESC** key to open the menu.
2. Place the cursor on the desired function and select to highlight it in yellow. To register the timer function, left-click on the display "00:00:00" to highlight it in yellow.  
**Note:** To show/hide the timer, select [ON] or [OFF] in [Timer Display] menu of [Display Setting] menu.
3. Press desired function key for more than one second. The message shown below appears for five seconds.

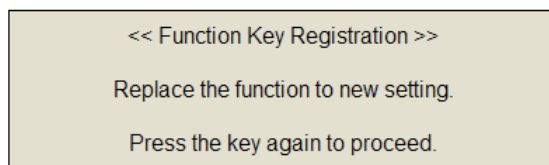

4. Press the same function key again, and the message shown below appears.

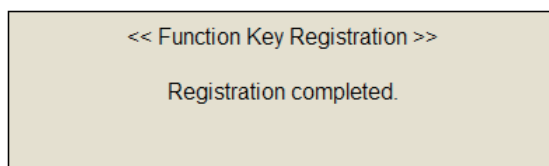

**Note:** The [Function Key Registration] window location can be adjusted. Consult a FURUNO technician to adjust the location.

## 6. HOW TO CUSTOMIZE THE SONAR

After registration is completed, the number of the function key appears on the left of the menu item or timer indication.

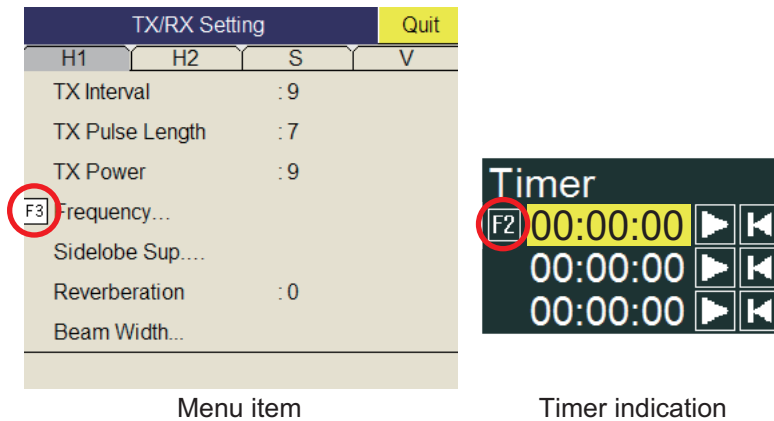

### 6.2.3 How to erase programs

1. Press the **MENU/ESC** key to open the main menu.
2. Select [Others] then push the left-click button.
3. Select [Register] then push the left-click button.

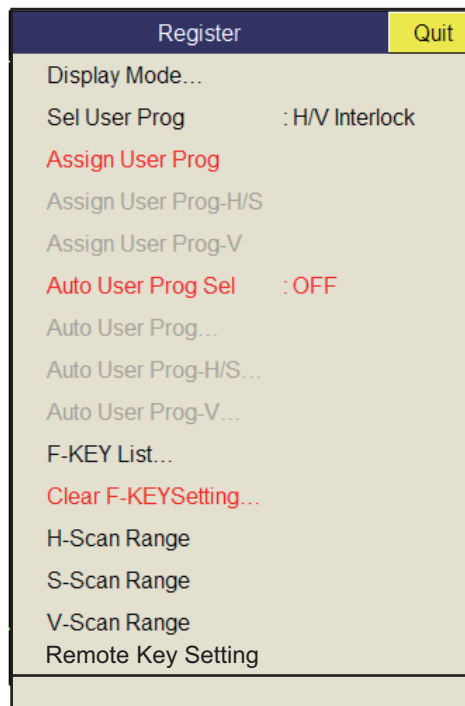

4. Select [Clear F-KEY Setting] then push the left-click button.
5. Select [Changeable] then push the left-click button.
6. Select the function key for which you want to erase its program then push the left-click button. Repeat this step for other function keys.
7. Select [Quit] on the setting box then push the left-click button.
8. Long-press the **MENU/ESC** key to close all menus.

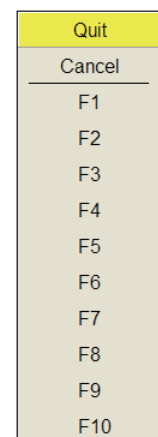

## 6.2.4 How to program the function keys of sub control unit

You can program the function keys (**F1-F4**) on the sub control unit (option) to provide one-touch access to the functions of the keys on the control unit.

The function of the following control unit keys can be assigned to the function keys on the remote controller.

- **V1/S** key
- **V2** key
- **EVENT** ⊕ (or ⊗) key
- **OFF CENTER** key
- **ESTIMATE 1** (or **2**) key
- **SHOOT** key
- **R/B AUDIO** key
- **DELETE MARK** key
- **TARGET LOCK** key
- **FISH** key
- **AUTO TRAIN** key
- **DISP MODE** key
- **H/V/S** key
- **1/F1 to 4/F4** key

The default setting of the **1/F1** to **4/F4** key is same as those on the control unit. To change a setting, do as follows:

1. Press the **8/F8**, **9/F9**, and **10/F10** keys in order while pressing the **MENU/ESC** key to activate the program registration mode on the sub control unit.
2. Press the **MENU/ESC** key to close the menu.
3. Press and hold down the applicable key of the control unit and then press a function key of the sub control unit.  
When the registration is completed, the buzzer sounds.
4. Operate the function key programmed to confirm functionality.
5. Repeat steps 1 to 4 to program the another function key.

## 6.3 USER PROG Control

The **USER PROG** control provides for instant setup of the equipment according to fishing ground or target fish. Ten programs may be set up, and vertical and horizontal display settings may be programmed together or individually. (The default settings programs them together. For how to program them individually see section 6.3.2.)

### 6.3.1 How to select a user program

Rotate the **USER PROG** control clockwise or counterclockwise to select the program desired. The program no. selected appears at the top right-hand corner of the screen to the right of "P". If the equipment is turned off with a user program active, it starts up with those settings at the next power on.

**Note:** The user program no. can also be adjusted from the user program no. indication. Put the cursor on the user program no. indication to highlight it in yellow then roll the scrollwheel.

### 6.3.2 How to program the USER PROG control

1. Set the display appropriately.  
When a combination mode is shown, press **H/V/S** key to select the display to program.
2. Press the **MENU/ESC** key to show the main menu.
3. Select [Others] then push the left-click button.
4. Select [Register] then push the left-click button.

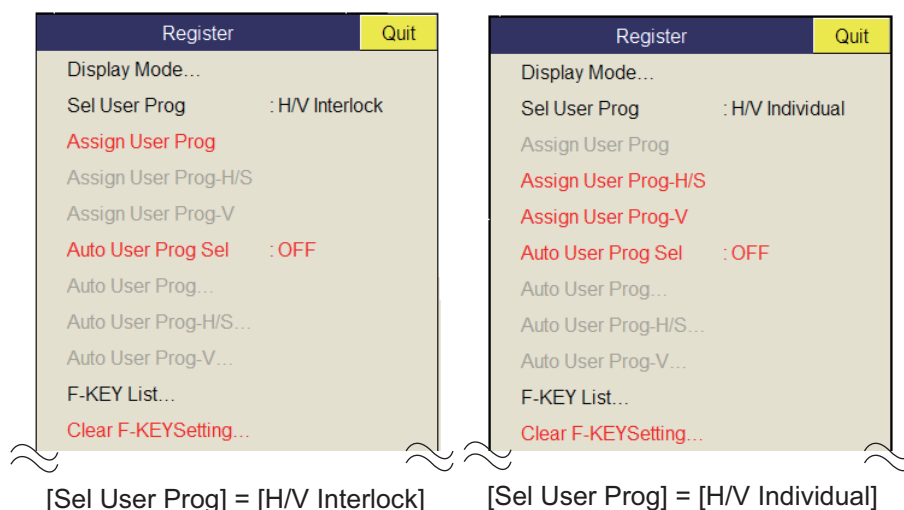

\*: H/V Interlock: Effective on both H and V displays.  
H/V Individual: Select the display to use with the **H/V/S** key. (In operative on the slant display).

5. Do one of the following then push the left-click button.
  - For H/V Interlock: Select [Assign User Prog].
  - For H/V Individual: Select Assign [User Prog-H/S] or [Assign User Prog-V].



6. Select [Changeable] then push the left-click button. One of the following displays appears depending on your selection.

Quit	Quit	Quit
Cancel	Cancel	Cancel
P1	P1-H/S	P1-V
P2	P2-H/S	P2-V
P3	P3-H/S	P3-V
P4	P4-H/S	P4-V
P5	P5-H/S	P5-V
P6	P6-H/S	P6-V
P7	P7-H/S	P7-V
P8	P8-H/S	P8-V
P9	P9-H/S	P9-V
P10	P10-H/S	P10-V

“Assign User Prog”
“User Prog-H/S”
“User Prog-V”

7. Select a program no. then push the left-click button.  
 8. Select [Quit] on the setting box then push the left-click button.  
 9. Long-press the **MENU/ESC** key to close all menus.

**Note:** The slant mode user programs are effective when the slant display is selected.

**Slant display:** User programs for slant mode. **Slant combination display:** Horizontal display user programs when horizontal display is active. Slant display user programs when slant display is active.

### 6.3.3 How to program display ranges

To use programmed ranges, turn on [Auto User Prog Sel]. For example, you set P3 for 200, P7 for 1000 m, etc. Then, the short and long ranges are selected alternately without operating the **USER PROG** control. Range assignment is done with [Auto User Prog] (for H/V Interlock) or [Auto User Prog-H]/[S/Auto User Prog-V] (for H/V Individual). Close the menu after you set ranges to activate user ranges.

## 6.4 Remote Controller (option)

The keys of the remote controller can be reprogrammed with the functions of your choice.

1. Open the menu.
2. Select [Others] then push the left-click button.
3. Select [Register] then push the left-click button.
4. Select [Remote key Setting] then push the left-click button.

Remote Key Setting		Quit
Ch1	: Tilt Up	
Ch2	: Tilt Down	
Ch3	: Range Up	
Ch4	: Range Down	
Ch5	: Gain Up	
Ch6	: Gain Down	
Ch7	: User Prog Up	
Ch8	: User Prog Down	
Ch9	: Display Mode	
Ch10	: Off Center	

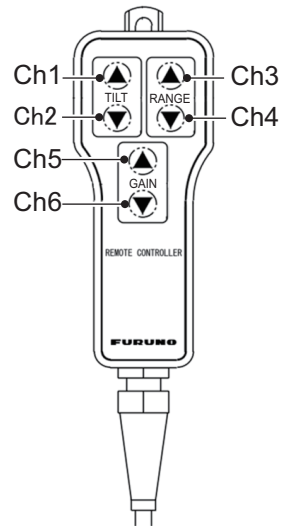

**Note:** [Ch7] through [Ch10] are only used when an external switch is connected to the TB1 port of the Processor Unit.

5. Select the item ([Ch1] to [Ch6]) corresponding to the key whose setting you want to change.
6. Left-click the function to register.
7. Left click [Quit] in the setting box.
8. Close the menu.

# 7. OTHERS MENU

This chapter provides descriptions for the [Others] menu. To display the [Others] menu, press the **MENU/ESC** key, select [Others] then push the left-click button.

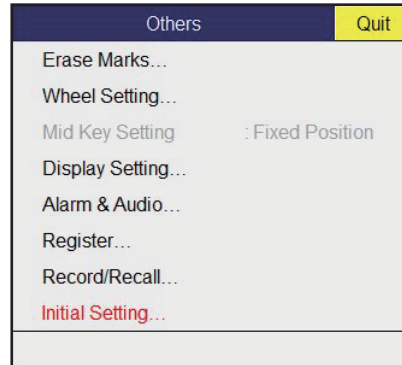

The [Record/Recall] menu is described in Chapter 8. Also, menu items shown in gray cannot be accessed.

## 7.1 Erase Marks Menu

The [Erase Marks] menu lets you delete selected marks and track.

1. Select [Erase Marks] on the [Others] menu then push the left-click button. This menu can be also opened from the right-click pop up menu.

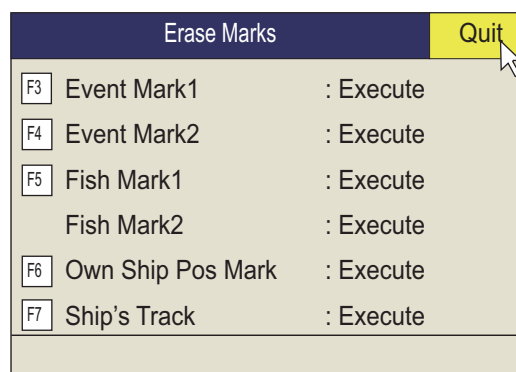

2. Select the mark (or track) you want to delete then push the left-click button. The earliest mark is deleted. For ship's track, approximately 10% of the track is erased with each push of the left-click button.
3. To continue erasing marks, push the left-click button.
4. Long-press the **MENU/ESC** key to close all menus.

**Note:** The default function of the **3/F3** (for event mark 1), **4/F4** (for event mark 2), **5/F5** (fish mark 1) and **6/F6** (for own ship position) keys delete the oldest event mark, fish mark, own ship mark. The default function of the **7/F7** key erases approximately 10% of the track.

## 7.2 Wheel Setting Menu

One of the following functions can be assigned to the scrollwheel.

- Tilt angle
  - Gain
  - Range
  - Turn Angle (Slant display only)
  - Bearing (Vertical display only)
1. Select [Wheel Setting] on the [Other] menu then push the left-click button.  
This menu can be also opened from the pop-up menu.

Wheel Setting		Quit
H Mode	:	Tilt Angle
S Mode	:	Tilt Angle
V Mode	:	Bearing
Wheel	:	Reverse

2. Select [H Mode], [S Mode], [V Mode] or [Wheel] then push the left-click button.

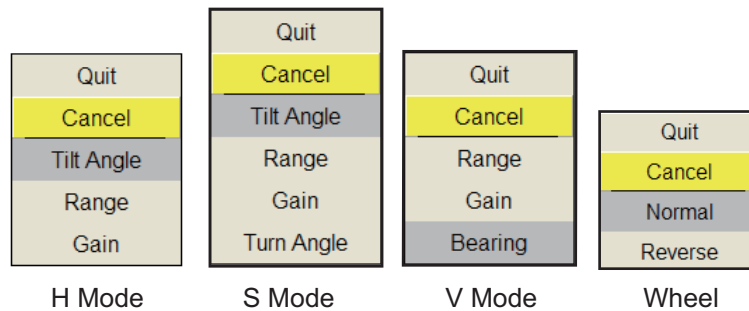

3. Select the function to assign to the scrollwheel then push the left-click button.
4. Select [Quit] on the setting box then push the left-click button to close the box.
5. Long-press the **MENU/ESC** key to close all menus.

## 7.3 Display Setting Menu

The [Display Setting] menu sets various display-related items according to operator's preference. To display the menu, open the main menu then select the [Others] and [Display Setting] menus.

Display Setting		Quit
TX/RX Mode	: Alternative	
Mode Selection	: Mode Key	
Echo Disp Area	: Within Range	
F9 H2/S Display	: Landscape	
2nd Monitor Setting	: Portrait	
V-Scan Aspect Ratio	: Fixed	
V-Scan Dpt Rng	: 100	
F3 Presentation Mode	: Head Up	
TM Disp Range	: 1.6R	
Full Screen Area	: 1.6R	
Bearing Ref	: Ship Heading	
TILT lever	: Tilt	
Auto Tilt	: Narrow	
S Auto Off Cent	: OFF	
Net Course Mark	: Execute	
F4 Dimmer	: 7	
Key Beep Volume	: 5	
TimerDisplay	: OFF	
Circle Cursor Diameter	: 200m	
Disp. Hull Unit Status	: ON	

**TX/RX Mode:** Select how to transmit and receive in combination displays. [Alternative] executes TX and RX one display at a time. [Multi] simultaneously executes TX and RX on each display. This item is inoperative (shown in gray) in the following cases.

- [Sidelobe Sup.A] on the [Sidelobe Sup.] menu is set between -3 and -1.
- [Sidelobe Sup.B] on the [Sidelobe Sup.] menu is set to a value other than 0, and [RX Beam Control] on the Beam Width menu is set to a value other than 0.

**TX/RX Mode:** Determines how display modes are chosen: **MODE** key or pull-down menu.

**Echo Disp Area:** Selects the echo display mode for the horizontal and slant displays, [Within Range] or [Full Screen].

**H2/S Display:** Selects the combination mode of horizontal and slant displays: Landscape, Portrait, or Inset.

**2nd Monitor Setting:** When two monitors are connected, select the combination mode for the sub-display; Landscape or Portrait. This function is available only when [Dual Display] is selected at [2nd Monitor Setting] on [Others]-[Initial Setting] menu.

**V-Scan Aspect Ratio:** Selects the type of the horizontal to vertical ratio to use on the V-display; Fixed or Flexible.

**V-Scan Dpt Rng:** Selects the ratio to shrink the display range in the vertical direction. This item is available only when [Flexible] is selected at [V-Scan Aspect Ratio] in above.

**Presentation Mode:** Selects presentation mode. Head-up, North-up, Course-up and true motion (requires ship's speed and heading data) are available.

**TM Disp Range:** Selects how many times to expand the display range in the true motion mode. 1.3R (R=Range) and 1.6R are available.

**Note:** When you set [TM Disp Range] to 1.3R and [Full Screen Area] to 1.6R, the full screen area for the TM mode becomes 1.6R.

**Full Screen Area:** Selects a configuration for the full screen display, 1.3R or 1.6R.

**Bearing Ref:** Selects how to reference bearing for the vertical bearing marker. The choices are ship's heading and North.

**TILT lever:** Selects function of the **TILT** control. [Tilt] sets the tilt only. [Tilt & V1] sets the bearing of the vertical 1 display in the vertical display and sets the tilt in the horizontal display./

**Auto Tilt:** Selects the auto tilt angle, Wide ( $\pm 2^\circ$  to  $10^\circ$ ,  $\pm 4^\circ$  to  $16^\circ$ ,  $\pm 6^\circ$  to  $20^\circ$ ) or Narrow ( $\pm 1^\circ$  to  $4^\circ$ ,  $\pm 2^\circ$  to  $6^\circ$ ,  $\pm 3^\circ$  to  $8^\circ$ ).

**Net Course Mark:** Inscribes/deletes the net course mark. For further details see section 2.20.

**Key Beep Volume:** Sets the volume of the beep which sounds for key operation. The setting range is 0-7. "0" turns off the key beep.

Dimmer: Change the brightness of the panel and keys. The setting range is 0-15.

**TimerDisplay:** Set [ON] to show the timer window at the bottom left of the display. The timer window can be moved by drag and drop operation. Operate the timer window as shown below.

1. Select [▶] on the timer window and push the left-click button to start the timer.  
The icon [▶] on the timer window changes to [●].
2. Select [●] on the timer window and push the left-click button to stop the timer.  
The icon [●] on the timer window changes to [▶].
3. Select [◀] on the timer window and push the left-click button to reset the timer.

**Note:** Timer operation can be registered to function key. Refer to subsection 6.2.2 for the steps to register functions to function key. The following is the operation of the timer window when the function key is used.

- 1) Press the function key when the timer is stopped. The icon [▶] on the timer window changes to [●].
- 2) Press the same function key used in the step 1. The icon [●] on the timer window changes to [▶].

- 3) Press the same function key twice within one second to reset the timer. The timer window will change as shown on the right.



**Circle Cursor Diameter:** Sets the default diameter of the circle cursor.

**Disp. Hull Unit Status:** When set to [ON], the hull unit's status is displayed on-screen. Set to [OFF] to hide the status display.

## 7.4 Alarm & Audio Menu

The [Alarm & Audio] menu sets the fish alarm and the audio bearing mark sector. To show this menu, open the main menu, then open the [Others] and [Alarm & Audio] menus.

Alarm & Audio		Quit
Fish Alarm	: OFF	
Alarm Level	: 16	
Alarm Zone...		
Ship SPD Alarm	: ON	
Audio	: ON	
Audio Volume		
Audio Sector	: 30°	
Reverberation	: 0	

**Fish Alarm:** Turns the fish alarm function on or off. The default setting is off.

**Alarm Level:** Sets the minimum echo color which triggers the fish alarm. The setting range is 0-30.

**Alarm Zone:** Sets fish alarm zone.

**Ship SPD Alarm:** The default setting is ON. The alarm is released if ship's speed exceeds the following limits: Lowering transducer: 18 knots Raising transducer: 15 knots

**Audio:** Turns the audio function on/off.

**Audio Alarm:** Adjusts the volume of the buzzer.

**Audio Sector:** Selects the audio sector width for use with audio function.

**Reverberation:** Selects the length of reverberation for audio signal. The setting range is 0-9 and 0 is no reverberation. The larger the value, the longer the reverberation.

## 7.5 Register Menu

The [Register] menu provides various programming functions. To show this menu, select [Register] on [Others] menu then push the left-click button.

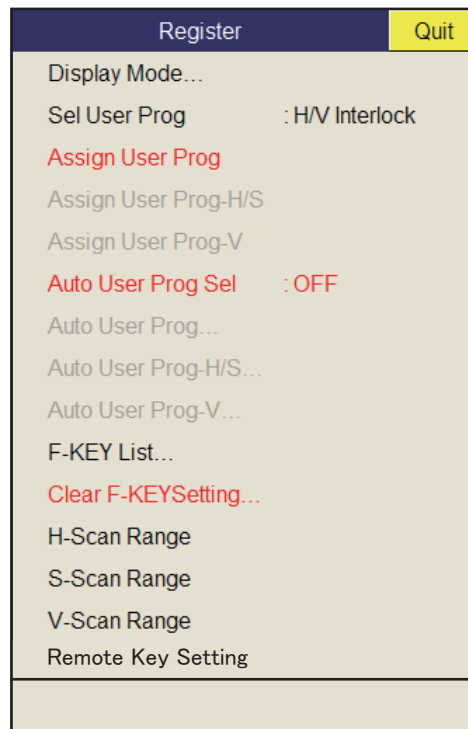

[Sel User Prog] = [H/V Interlock]

**Sel User Prog/Assign User Prog/Auto User Prog Sel/Auto User Prog:** Programs the **USER PROG** control. For further details see section 6.3.

**Display Mode:** Selects the display mode to use.

**F-KEY List:** Shows the functions assigned to each function key.

F1 Record Still Image	F2 Recall Still Image	Confirm
F3 Event Mark1	F4 Event Mark2	
F5 Fish Mark1	F6 Own Ship Pos Mark	
F7 Ship's Track	F8 Dimmer	
F9 Stabilization	F10 Net Course Mark	

**Clear F-KEY Setting:** Erases program assigned to a function key.

**H-Scan Range:** Presets the horizontal mode ranges as selected with the **RANGE** control. The setting range is 60-2000 m.

**S-Scan Range:** Presets the slant mode ranges as selected with the **RANGE** control. The setting range is the same as that for [H-Scan Range].

**V-Scan Range:** Presets the vertical scan ranges as selected with the **RANGE** control. The setting range is the same as that for [H-Scan Range].

**Remote Key Setting:** Presets the functions to the keys of the remote controller (see section 6.4).



## 7.6 Initial Setting Menu

The [Initial Setting] menu sets up mark size, current vector, net sonde, target lock, etc.

1. Press the **MENU/ESC** key to show the main menu.
2. Select [Others] then push the left-click button.
3. Select [Initial Setting] then push the left-click button.
4. Select [Changeable] then push the left-click button.

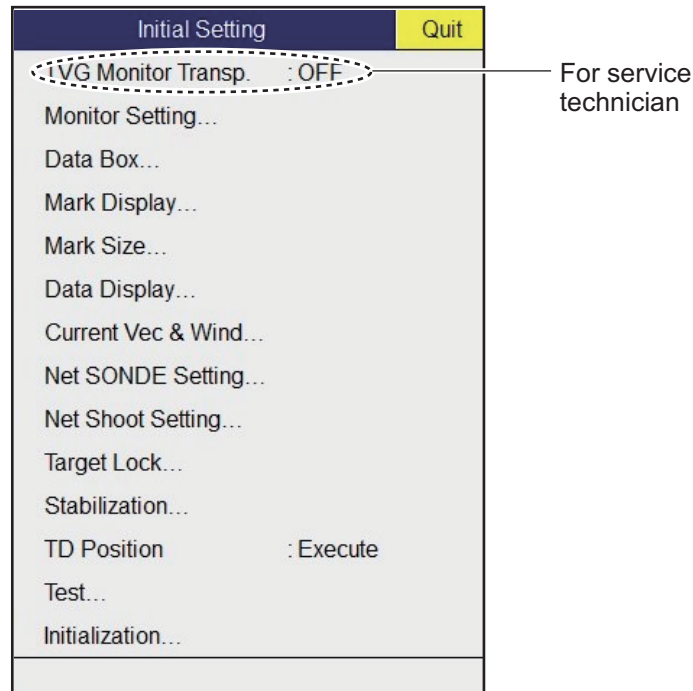

For Target Lock and Test, see page 2-21 and page 9-12, respectively.

**Note:** Alpha blending technology is used for transparency effects.

### 7.6.1 Monitor Setting menu

The [Monitor Setting] menu sets the function of dual monitors. Select [Monitor Setting] on the [Initial Setting] menu then push the left-click button.

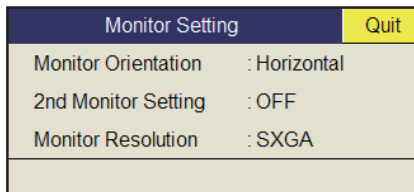

#### Monitor Orientation

Selects the monitor's orientation (Horizontal, Vertical). To apply the setting, turn the power off, then on again.

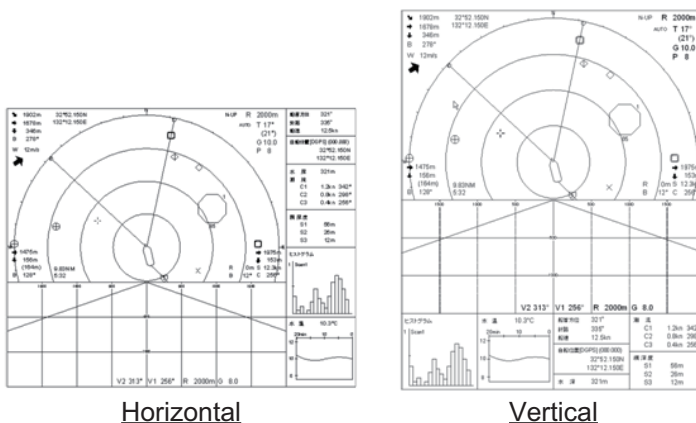

**Note:** In vertical orientation, [Menu Transparency] and [Display Transparency] settings are not available.

#### 2nd Monitor Setting

Selects the display format for the sub monitor (Off, Dual Display, Sub Display).

Turn the power off and on again after you change this setting.

- OFF: Select if a single monitor is connected.
- Dual Display: Main and sub monitors show different pictures in the combination display mode.
- Sub Display: Main and sub monitors show the same picture in the combination display mode.

Display mode	Dual Display		Sub Display	
	Main monitor	Sub monitor	Main monitor	Sub monitor
H2	H1	H2	H1/H2	H1/H2
H/S	H	S	H/S	H/S
V1	H	V1	H/V1	H/V1
V2	H	V1/V2	H/V1/V2	H/V1/V2

#### Monitor Resolution

[Monitor Resolution] options are [SXGA], [UXGA] and [WUXGA]. To reflect the setting change, turn on/off the power. After changing the monitor resolution, the size and display position of vertical display will change. Proceed with Monitor Setting as appropriate. (Refer to section 3.3.)

## 7.6.2 Data Box menu

The [Data Box] menu sets the readout format for the marks on the display. Select [Data Box] on the [Initial Setting] menu then push the left-click button. This menu is also shown on the pop-up menu.

Data Box		Quit
Data Box	: ON	

**Data Box:** Turns the numeric/graphic data display on/off.

## 7.6.3 Mark Display menu

The [Mark Display] menu turns on/off marks. Select [Mark Display] on the [Initial Setting] menu then push the left-click button.

Mark Display		Quit
Heading Mark	: ON	
Range Rings	: ON	
Bearing Scale	: Coarse	
Azimuth Compass	: ON	
Lat/Lon Lines	: ON	
Own Ship's Track Plot	: ON	
Data On Track	: OFF	
Net Move Plot	: ON	
Fish Mark Connect	: ON	
Target Vector	: ON	
Fish Track Plot	: ON	
EVENT Key	: Event	
Histogram Disp.	: ON	
Mark Color	: White	
TD Position Mark	: ON	

**Heading Mark:** The heading mark is a dashed line which indicates the heading in all presentation modes. It extends from own ship position to the outer edge of the display and appears at zero degrees in the head-up mode. It changes the orientation depending on ship's orientation in the north-up, course-up and true motion modes.

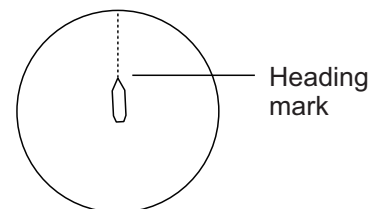

**Range Rings:** The range rings are the dotted line circles about own ship, and they provide an estimate of the range to a target. Rings appear every distance of 1/2 or 1/4 of the range depending on menu setting.

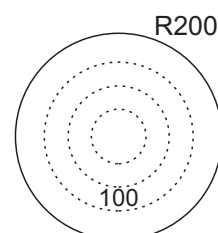

7. OTHERS MENU

**Bearing Scale:** The bearing scale is the concentric solid circle at the edge of the display. It provides an estimate of the bearing to a target. Choose from [OFF], [Coarse] or [Fine].

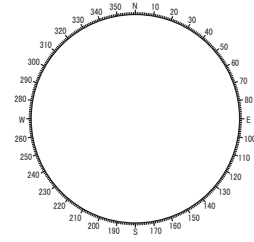

**Own Ship's Track Plot:** Traces ship's movement with a solid line. When the capacity of the track memory is exceeded the earliest track is automatically erased to trace new track. Requires speed and course data.

**Data On Track:** Shows depth or water temperature on the ship's track.

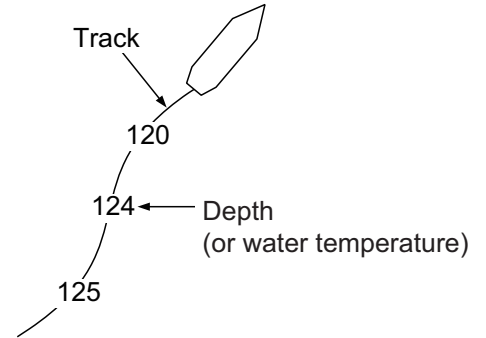

**Net Move Plot:** Shows predicted net movement against three current layers over time. Automatically turned on or off with the net shoot mark. Requires the current data.

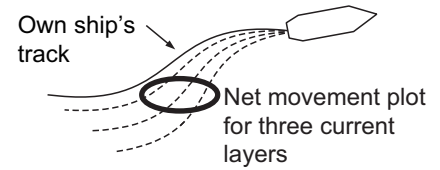

**Fish Mark Connect:** You may connect fish marks with a line to show the order in which they were entered.

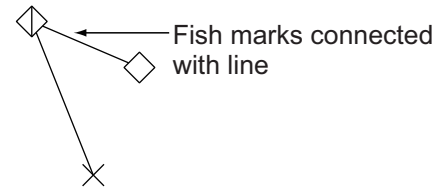

**Target Vector:** This is a line extending from the target lock mark, and it shows speed and direction of tracked school of fish. See the illustration below for appearance.

**Fish Track Plot:** Traces target movement in target lock. Requires speed and course data.

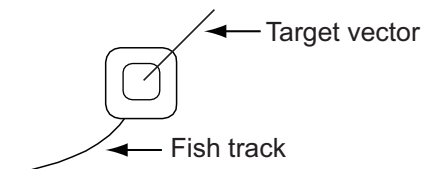

**EVENT Key:** Selects the key to enter the own ship's position mark (Event key, Shoot key).

**Histogram Disp.:** Shows signal strength distribution for the school(s) of fish marked with an estimate mark on the horizontal or slant display.

**Mark Color:** Selects the color of the event, fish school, and fish estimate marks. (Setting range: White, Baby Blue, Blue, Yellow, Purple, Green) The mark color can not be set individually.

**Transducer Position Mark:** Selects whether to display the transducer position mark or not. See subsection 1.3.3.

## 7.6.4 Mark Size menu

The [Mark Size] menu lets you select the size and shape of the marks. Select [Mark Size] on the [Initial Setting] menu then push the left-click button.

Mark Size		Quit
Trackball Mark	: + Small	
Target Lock Mark	: Normal	
Auto Fish Mark	: Small	
Target Vector	: Small	
Event Mark	: Large	
Fish Mark	: Large	
Own Ship Pos Mark	: Normal	
Own Ship Mark	: Actual	
Net Shoot Mark	: Normal	
Estimate On Scan	: Large	
Current Vector	: Small	
Range Ring Interval	: 1/4R	
Bearing Scale	: Small	
Own Ship's Track Plot	: 5R	

**Trackball Mark:** Selects size and appearance of cursor. The choices are large and small "+" mark, and large and small "■" mark.

**Target Lock Mark:** The target lock mark size is available in normal, large, or small.

**Target Vector:** You may display the target vector in short, normal, or long lengths. Set "long" for slow moving target; "short" for faster moving target.

**Event Mark:** Selects event mark size; normal, large, or small.

**Fish Mark:** Displays the fish mark in normal, large, or small size.

**Own Ship Pos Mark:** Shows the own ship position mark in normal, large, or small size.

**Own Ship Mark:** Selects size of own ship mark to standard, large, or actual.

**Net Shoot Mark:** You may show the net shoot mark in normal, large, or small size.

**Estimate On Scan:** Selects the size of the fish estimate mark on the horizontal display for large or small.

**Current Vector:** The length of the current vector may be set to short, long, short/thick, or long/thick.

**Range Ring Interval:** Selects the range ring interval; 1/4R, 1/2R (R=Range) or Auto. When Auto is selected, the number of range rings changes from three to five depending on displayed range. For example, when the range is 500 m, five range rings will appear with 100 m between each ring.

## 7. OTHERS MENU

**Bearing Scale:** Selects the size of the bearing scale for normal or large size.

**Own Ship's Track Plot:** Selects the amount of track to display; 5R, 10R, 20R, 40R (R=Range).

### 7.6.5 Data Display menu

This menu turns on/off alphanumeric data. Select [Data Display] on the [Initial Setting] menu then push the left-click button.

Data Display		Quit
Range&Bearing	: ON	
Fishing Area	: OFF	
Cursor Position	: OFF	
Course	: 32 CMPS	
Current Data	: 360°True	
Event Mark	: 32 CMPS	
Other Marks	: ±180°	
Distance For Shoot	: NM	
Water Temp	: °C	
Water Temp Range	: 20 Minute	

**Range/Bearing:** Turns on/off the range and bearing data which appears when the range/bearing marks are turned on.

**Fishing Area:** Not used.

**Cursor Position:** Turns on/off the cursor position (latitude and longitude) display. (Requires navigation data.)

**Note:** When [EXT Data] on [Setting]-[Lat/Lon] on system menu is set to [Disable], the cursor position is not displayed even if the [Cursor Position] on [Initial Setting]-[Data Display] is set to [ON]. For the System menu, contact your dealer.

**Course:** Selects how to display course; [32 CMPS] (32 compass points), [360°True] (true bearing), [360°] (360° Relative), [±180°] (180° Relative). [±180°] shows xxxS in case of starboard direction; xxxP in case of port direction (xxx: 1 to 180). Heading sensor is required to set to [360°True]. [32 CMPS] shows bearing with alphabet indication, for example, "N";, "N/E", "NNE", "NE1/N", etc. Only [±180°] is available for the turn angle of the slant display.

**Current Data:** Selects how to display tidal current data; [32 CMPS] (32 compass points), [360°True] (true bearing), [360°] (360° Relative), [±180°] (180° Relative).

**Event Mark:** Selects how to display event mark data; [32 CMPS] (32 compass points), [360°True] (true bearing), [360°] (360° Relative), [±180°] (180° Relative).

**Other Marks:** Selects how to display other mark data; [32 CMPS] (32 compass points), [360°True] (true bearing), [360°] (360° Relative), [±180°] (180° Relative).

**Distance For Shoot:** Selects the distance run unit to show the distance run after shooting the net. The options are miles, meters and feet.

**Water Temp:** Selects water temperature unit; in °C (Celsius) or °F (Fahrenheit).

**Water Temp Range:** Selects the time range to show water temperature, 20 Minute, 1 Hour, 6 Hours, 12 Hours or 24 Hours.

### 7.6.6 Current Vec & Wind menu

The [Current Vec & Wind] menu sets up tidal current and wind data. Select [Current/Wind] on [Initial Setting] menu then push the left-click button.

Current Vec & Wind		Quit
Current Data	:	Water Current
On Own Ship Mark	:	ON
On Ship Pos Mark	:	ON
On Net Shoot Mark	:	ON
Current Flow Dir	:	To
Wind	:	OFF
Select Water Current		

**Current Data:** Selects how to display current data; absolute or in relation to layer 1, layer 2 or layer 3 or layer 4 or layer 5.

**On Own Ship Mark:** Shows or hides the current mark on the own ship mark.

**On Ship Pos Mark:** Shows or hides the current mark on the own ship position mark.

**On Net Shoot Mark:** Shows or hides the current mark on the net shoot mark.

**Current Flow Dir:** Selects how to display current data. [FROM] shows from what direction the current is flowing; [TO] shows the direction the current is heading. Requires connection of a current indicator.

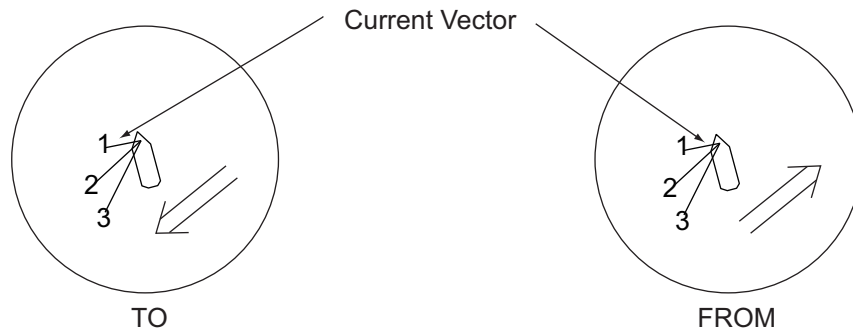

**Wind:** Selects wind display; OFF, relative wind data or true wind data.

**Select Water Current:** Select water current to show. Select the [Select Water Current] and right click, the setting box is shown. Then, select the water current (Max. 3). Selected water current is shown with [✓].

### 7.6.7 Net SONDE Setting menu

The [Net SONDE Setting] menu sets up the net sonde. Select [Net SONDE Setting] on [Initial Setting] then push the left-click button.

Net SONDE Setting		Quit
Number Of XMTR *	: 3	
XMTR Distance... *		
Net Length	: 1800m	
Depth Display...		
Display Style	: Numeric	
Depth Graph Range	: 100m	

\*Setting cannot be adjusted after the net is thrown.

**Number Of XMTR:** Sets number of transmitter units used, from 0-10. When the total value of [XMTR Distance] is smaller than the setting value of [Net Length], max. 10 transmitter units can be used.

**XMTR Distance:** Sets the distance between transmitters. Select this item then push the left-click button to set the distances.

XMTR Distance		Quit
End Of Net To S1	: 400m	
S1->S2	: 400m	
S2->S3	: 400m	
S3	: 400m	

**Net Length:** Sets net length in increments of 100 m. Setting range is 1200 m\* to 3000 m.

\*: The minimum setting range for net length varies, depending on the settings for [Number of XMTR] and [XMTR Distance].

**Depth Display:** Selects which sonde depth data to show. Select this item and push the left-click button to select net sondes. The check mark shows current selection (Max. 3).

**Display Style:** Selects the display format of the net depth, Numeric or Graph.

**Depth Graph Range:** Sets the depth range of SONDE graph. The setting range is 50 m, 100 m, 150 m, 200.

Quit	
Cancel	
✓	S1
✓	S2
✓	S3



## 7.6.8 Net Shooting Setting menu

The [Net Shooting Setting] menu sets up net shoot parameters. Selects [Net Shooting Setting] on [Initial Setting] then push the left-click button.

Net Shoot Setting		Quit
Net Diameter	: 500m	
Tilt Interlock	: ON	
Net Plot Corr-LYR1	: 50%	
Net Plot Corr-LYR2	: 50%	
Net Plot Corr-LYR3	: 50%	
Net Plot Corr-LYR4	: 50%	
Net Plot Corr-LYR5	: 50%	

**Net Diameter:** Sets net diameter in increments of 10 meters. Setting range is 200 m to 1000 m.

**Tilt Interlock:** Turns on/off interlocking of diameter of net course mark with tilt angle.

**Net Plot Corr-LYR1, 2, 3, 4, 5:** The movement of the net during net shooting is plotted using water current speed and direction fed from a current indicator. The current indicator feeds that data for five depths (layers), thus net movement will be different at each layer. Determine degree of difference among layers considering net, sea conditions, etc. If 50% is set, for example, the net movement plot mark moves at speed of 50% of water current speed.

## 7.6.9 Stabilization menu

The [Stabilization] menu compensates for the affects of pitching and rolling. Select [Stabilization] on Initial [Setting menu] then push the left-click button. Requires a inertial measurement unit.

Stabilization		Quit
<b>F9</b> Stabilization	: OFF	
Pitch Angle Cor	: 0.0	
Roll Angle Cor	: 0.0	
Sensor	: Standard	

**Stabilization:** Turns stabilization on/off.

**Note:** The default function of the **9/F9** key turns stabilization on/off.

**Pitch Angle Cor:** Offsets the pitch angle error generated by the inertial measurement unit.

**Roll Angle Cor:** Offsets the roll angle error generated by the inertial measurement unit.

**Sensor:** Select the type of the inertial measurement unit used, FURUNO inertial measurement unit or GPS gyro (satellite compass).

### 7.6.10 Initialization menu

Select [Initialization] on [Initial Setting] menu then push the left-click button to show the [Initialization] menu.

Initialization	Quit
Save Ship's Org : Execute	
Recall Ship's Org : Execute	
Set To Default : Execute	
Item Attribution : Non-Changeable	
Date&Time Setting...	
Processor Unit IP : 4	

**Save Ship's Org:** All menu settings are saved.

**Recall Ship's Org:** Recalls the saved menu settings. Default settings are memorized in the internal memory. Use this item to recall the setting then rotate the **USER PROG** control.

**Set To Default:** Restores all default menu settings.

**Note 1:** The hull unit must be fully retracted before restoring default settings. After applying the settings, restart the equipment.

**Note 2:** The transducer position setting is also set to default and the message "UNREGISTERED" appears. See the Installation Manual (IME-13670) for how to enter transducer position.

**Item Attribution:** Locks/unlocks protected menu settings. Asterisk-marked items on this page and [Ship Speed] in the [Alarm & Audio] menu cannot be adjusted by the user.

Date&Time Setting: Sets date, time and time zone.

Date&Time Setting	Quit
Year : 2018	
Month : 1	
Date : 1	
Hour : 0	
Minute : 0	
Second : 0	
Timezone	

Processor Unit IP: Changes the IP address of the processor unit. After changing the setting, a restart message appears. Restart the processor to apply the new IP number.

Processor Unit IP : 172. 31. 10. xxx  
   └ Fixed                          └ Changeable from 1 to 254

# 8. RECORD/RECALL OPERATION

You can take still images of the display and store them internally.

## 8.1 How to Specify Where to Save Still Images

You can specify where to save still images as follows:

1. Push the right-click button on the numeric/graphic data display to show the pop-up menu.
2. Select [Record/Recall] then push the left-click button.

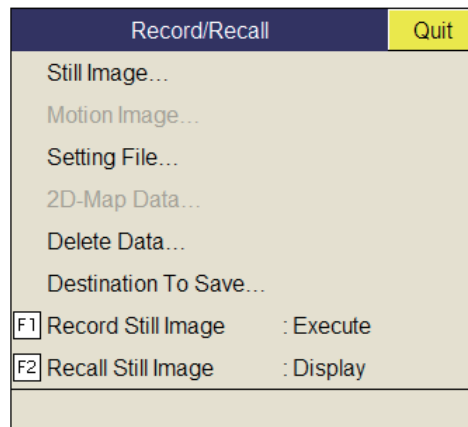

3. Select [Destination To Save] then push the left-click button.

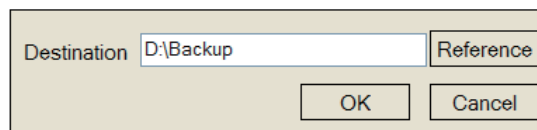

4. Select [Reference] on the Destination To Save window then push the left-click button.

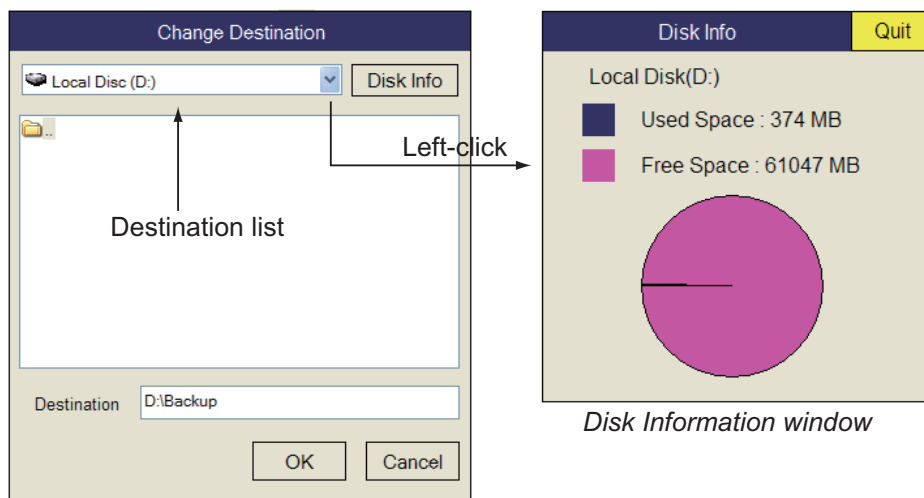

**Note:** Disk capacity of the D drive is subject to change.

5. Specify the location where to save the still image from the pull-down menu. "D" drive saves a still image to a folder whose name is automatically given the current data (yyyy.mm.dd).

## 8. RECORD/RECALL OPERATION

6. Select [OK] then push the left-click button.
7. Long-press the **MENU/ESC** key to close all menus.

### 8.2 How to Save Still Image

You can save the picture on the display as a still image. Also, you can enter the comment for the image.

The still image data is saved at the location selected at section 8.1 with the setting data. Date and time are used for the name of the data automatically.

- Still image: “yyyy\_mm\_dd\_hh\_mm\_ss\_comment.jpg”
- Setting: “RECORD\_yyyy\_mm\_dd\_hh\_mm\_ss\_comment.dat”

#### Saving with the [Still Image] window

1. Right click the numeric/graphic data display to show the pop-up menu.
2. Click [Record/Recall].
3. Click [Still Image].

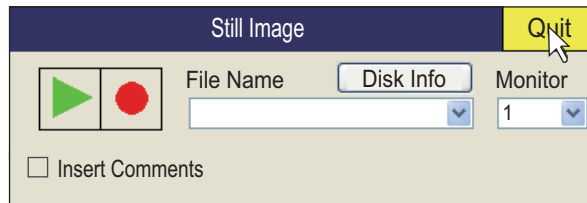

4. To enter a comment, check the box for [Insert Comments].
5. Click the [•] button on the [Still Image] window to save the still image. The picture at the moment the button is pushed is shown on the display (preview\*). If you checked the box for [Insert Comments], the software keyboard appears.  
\*: If you did not check the box for [Insert Comments], the preview disappears after four seconds.

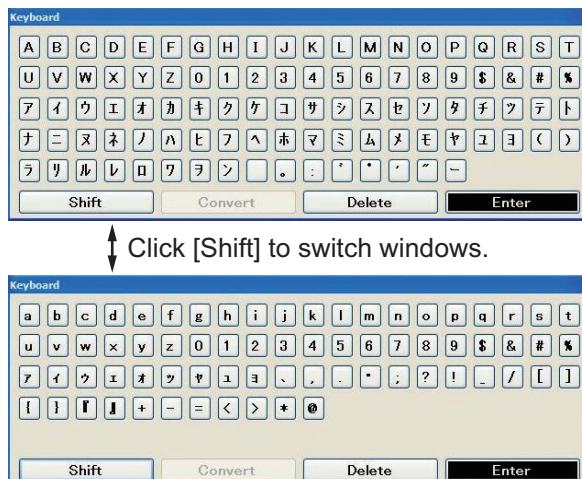

- [Shift]: Switches layout and type of characters and symbols.
- [Convert]: For future use.
- [Delete]: Deletes a previous character.
- [Enter]: Confirms data entry and closes the window.

6. Click the character or symbol to enter the comment (max. 20 characters or symbols).
7. Click [Enter] to close the software keyboard and the still image preview.
8. Click [Quit] on the [Still Image] window to close the window.

**Note 1:** If you check the box for [Insert Comments], you can enter a comment when you use [Record Still Image]. See the next topic.

**Note 2:** You can enter a comment only when saving the still image. You can not edit the comment when recalling a still image.

### **Saving with the [Record Still Image] menu**

1. Right click the numeric/graphic data display to show the pop-up menu.
2. Click [Record/Recall].
3. Click [Record Still Image].  
The picture at the moment the button is pushed is shown on the display (preview). If you checked the box for [Insert Comments], the software keyboard appears.
4. Click the character or symbol to enter the comment (max. 20 characters or symbols).
5. Click [Enter] to close the software keyboard and the still image preview.

**Note 1:** The default function of the **1/F1** key saves the still image.

**Note 2:** You can select how long to show the preview display. Contact your dealer for details.

### **Dual display**

Select the monitor on which to capture the still image, 1: main monitor, 2: sub monitor.

1. Right click the numeric/graphic data display to show the pop-up menu.
2. Click [Record/Recall].
3. Click [Still Image].

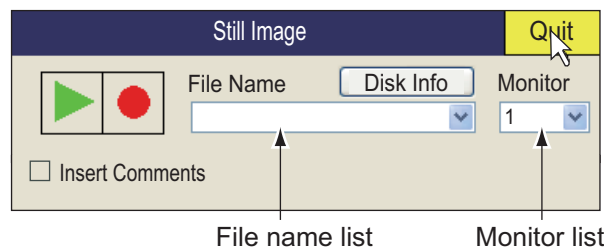

4. Select the monitor on which to capture the still image from the monitor list.  
1: main monitor, 2: sub monitor.
5. Click the [•] button on the [Still Image] window to save the still image.
6. Click [Quit] on the [Still Image] window to close the window.

## 8.3 How to Display Saved Still Images

There are two ways to display saved still images.

- Display the latest still image
- Display a still image from the file name list

### How to display the latest still image

1. Push the right-click button on the numeric/graphic data display to show the pop-up menu.
2. Select [Record/Recall] then push the left-click button.
3. Select [Recall Still Image] then push the left-click button.  
The latest still image is shown on the display.



**Note:** The window can be resized, and moved by drag and drop. Also, you can zoom in/out with the scrollwheel. Resize the window if the still image is not fully displayed.

4. Select [Quit] on the still image window then push the left-click button to close the window.

**Note:** The default function of the **2/F2** key displays the recalled still image window.

### How to display a still image from the file list

1. Push the right-click button on the numeric/graphic data display to show the pop-up menu.
2. Select [Record/Recall] then push the left-click button.
3. Select [Still Image] then push the left-click button.
4. Select a file from the file list.

5. Select the play button (green triangle) on the window then push the left-click button to recall still image window. A maximum of eight windows can be shown on the display.
6. Select [Quit] on the recalled still image window then push the left-click button to close the window.
7. Select [Quit] on the still image window then push the left-click button to close the window.

## 8.4 How to Save Settings

The FSV-85 MARK-2 can store the setting information in use as shown below.

1. Push the right-click button on the numeric/graphic data display to show the pop-up menu.
2. Select [Record/Recall] then push the left-click button.
3. Select [Setting File] then push the left-click button.

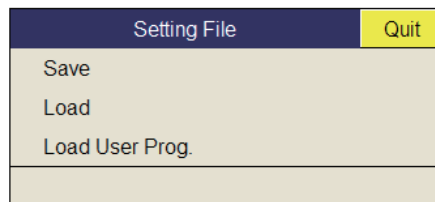

4. Select [Save] then push the left-click button.  
The file is given a name ("FSV85\_yyyy\_mm\_dd\_hh\_mm\_ss.ini") then shown in the box.

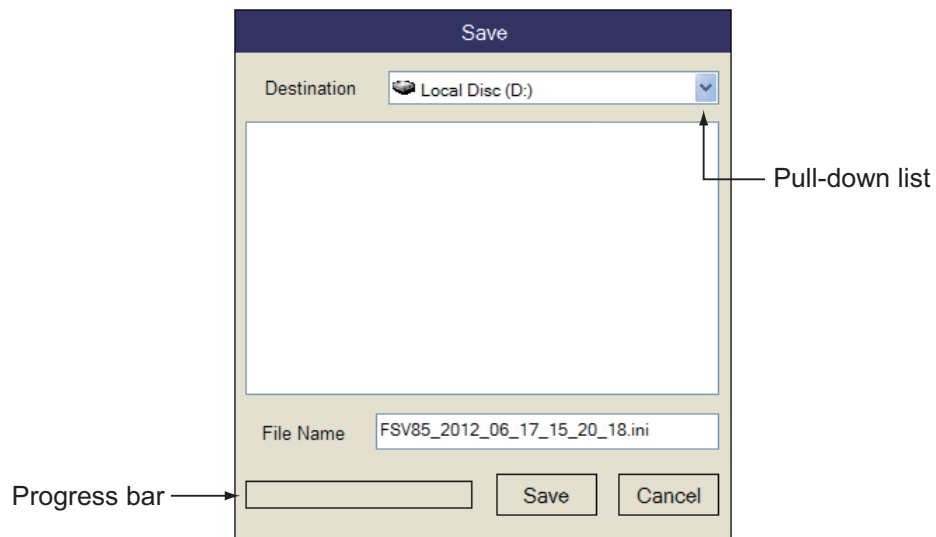

5. Select a destination to save from the pull-down list.
6. Select [Save] then push the left-click button.  
The progress bar at the bottom of the box shows the saving progress. The [Setting File] menu appears when the saving is completed.
7. Long-press the **MENU/ESC** key to close all menus.

**Note:** If the capacity at the destination is approaching maximum, the message "Disk capacity is approaching maximum. Delete unnecessary data." appears. In this case, select [Delete Data] then push the left-click button to delete unnecessary data.

## 8.5 How to Load Files

### 8.5.1 How to load the setting information

This section shows you how to load the setting information saved at section 8.4.

1. Push the right-click button on the numeric/graphic data display to show the pop-up menu.
2. Select [Record/Recall] then push the left-click button.
3. Select [Setting File] then push the left-click button.
4. Select [Load] then push the left-click button.

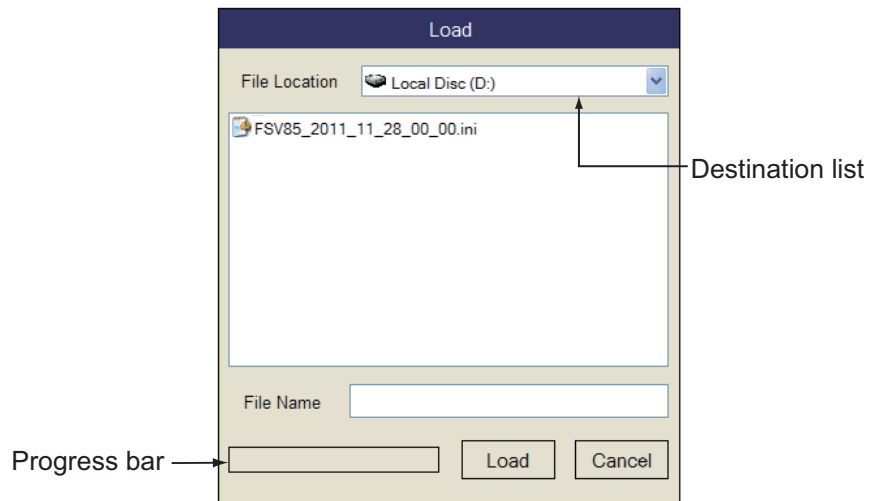

5. Select the file to load.
6. Select [Load] then push the left-click button.  
The progress bar at the bottom of the box shows the loading progress. The [Setting File] menu is appears when the saving is completed.
7. Long-press the **MENU/ESC** key to close all menus.



## 8.5.2 How to replay setting information

You may want to replay setting information to set up the equipment according to target fish or fishing ground.

1. Push the right-click button on the numeric/graphic data display to show the pop-up menu.
2. Select [Record/Recall] then push the left-click button.
3. Select [Setting File] then push the left-click button.
4. Select [Load User Prog] then push the left-click button.

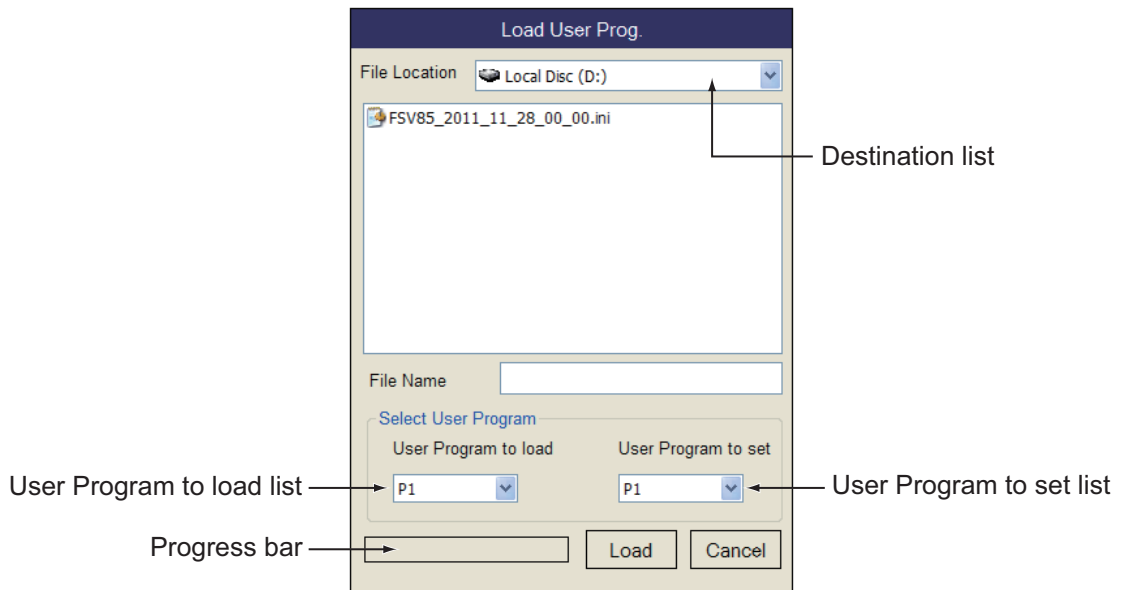

5. Select a file to load from the destination list.
6. Select the setting number from the [User Program to load] list then push the left-click button.
7. Select the setting number to load from the [User Program to set] list then push the left-click button.
8. Select [Load] then push the left-click button.  
The progress bar at the bottom of the box shows the loading progress. The [Setting File] menu appears when the saving is completed.
9. Long-press the **MENU/ESC** key to close all menus.

## 8.6 How to Delete Files

You can delete unnecessary files as shown below.

1. Push the right-click button on the numeric/graphic data display to show the pop-up menu.
2. Select [Record/Recall] then push the left-click button.
3. Select [Delete Data] then push the left-click button.

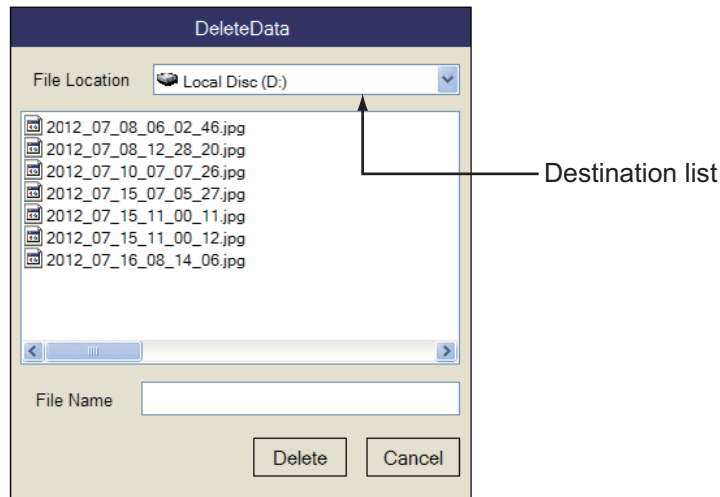



4. Select the file to delete.
5. Select [Delete] then push the left-click button. The message "Are you sure to delete?" appears.
6. Select [OK] then push the left-click button. The file selected at step 4 is deleted.
7. Long-press the **MENU/ESC** key to close all menus.

# 9. MAINTENANCE

---

This chapter provides maintenance and troubleshooting procedures for the operator.

 <b>WARNING</b>	
	<b>ELECTRICAL SHOCK HAZARD</b> Do not open the equipment.  This equipment uses high voltage that can cause electrical shock. Only qualified persons can work inside the equipment.

<b>NOTICE</b>
<b>Do not apply paint, anti-corrosive sealant or contact spray to plastic parts or equipment coating.</b>  Those items contain products that can damage plastic parts and equipment coating.

## 9.1 Preventative Maintenance

Regular maintenance is important for keeping the equipment in good working order. Check the following points on a regular basis.

- Check the cables for wear-and-tear and damage.
- Check the connectors are all securely fastened and free of corrosion.
- Check the grounding terminal for corrosion and damage. Also check that the equipment is correctly grounded.
- Approximately once per year, have a qualified technician check that the hull unit brake is working (see section 9.2).

### **Cleaning the equipment cabinet**

Dust or dirt can be removed from the equipment with a soft, dry cloth.

Do not use chemical cleaners to clean the equipment, they can remove paint and markings.

## 9.2 Hull Unit Maintenance

Care for the hull unit by following the procedures shown below.

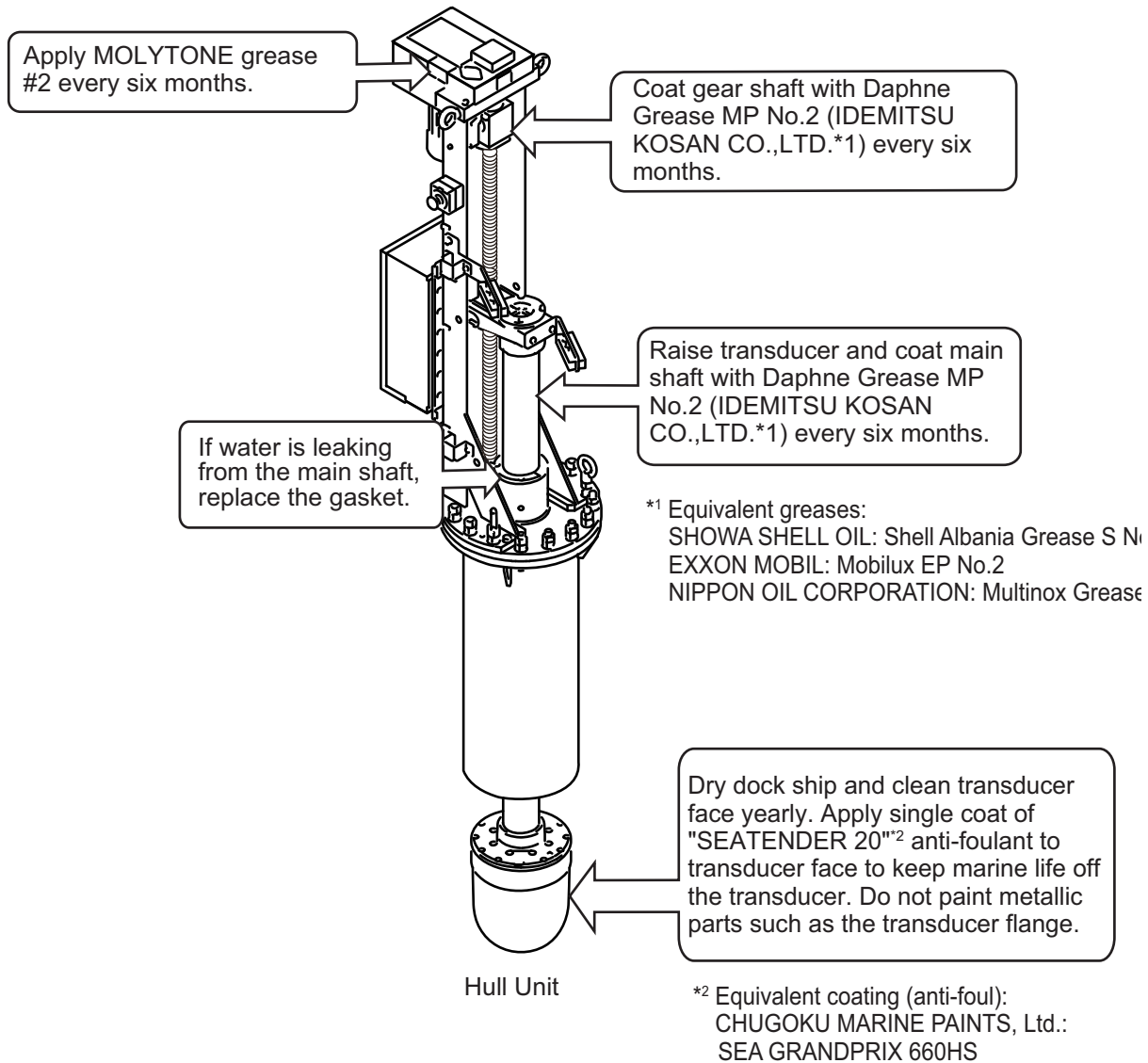

### CAUTION

**Replace anticorrosion zinc plate yearly.**

Corrosion between the main shaft and transducer may result, allowing water leakage and/or loss of transducer.

**Note 1:** Do not mix SEATENDER 20 with SEA GRANDPRIX 660HS, or apply one over the other.

**Note 2:** It is possible to remove SEATENDER 20 and replace the coating with SEA GRANDPRIX 660HS. To remove the current coating, soak a nylon-based scrubbing pad in thinners, then apply the thinner to the coating in a washing motion. To prevent damage to the transducer, do not use tools (scrapers, etc) or sandpaper to remove the coating.

## 9.2.1 How to grease parts

### How to grease the gear box

1. Unfasten the wing nuts from the gear box to remove the gear cover window.

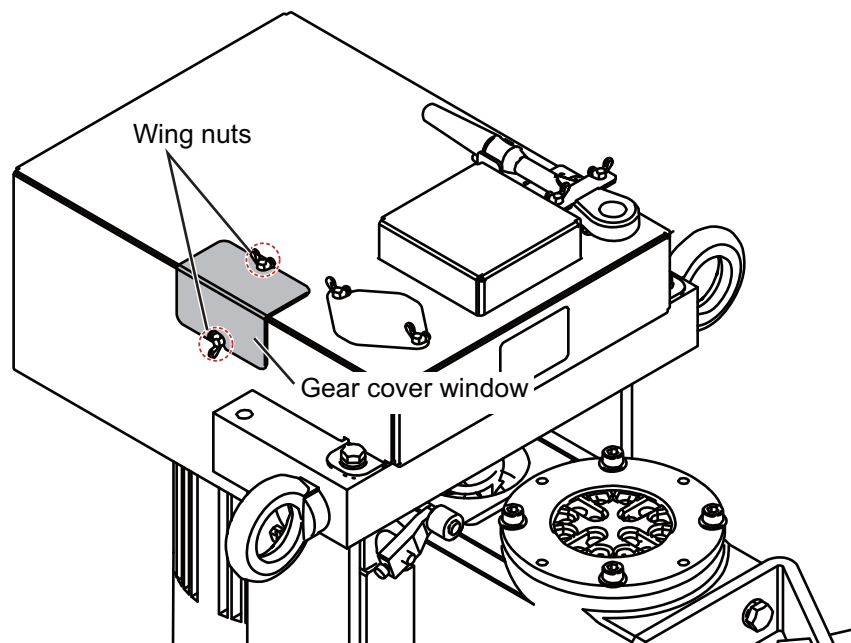

2. While raising and lowering the transducer manually with the ratchet wrench (see section 9.12.2), apply Molytone No.2 grease.

### How to grease the gear shaft

Inject Daphne Grease MP No.2 (IDEMITSU KOSAN CO.,LTD) to the grease nipple to grease the gear shaft.



Operation image

### 9.2.2 How to replace the gasket

If water is leaking from the main shaft, replace the gasket. A spare gasket is provided on the cover of the main shaft.

1. Unfasten four hex. head bolts to remove two seal support plates.
2. Cut and remove the old gasket.
3. Take the spare gasket from the cover of the main shaft cover and set it to the main shaft.
4. Fasten the two seal support plates removed at step 1.

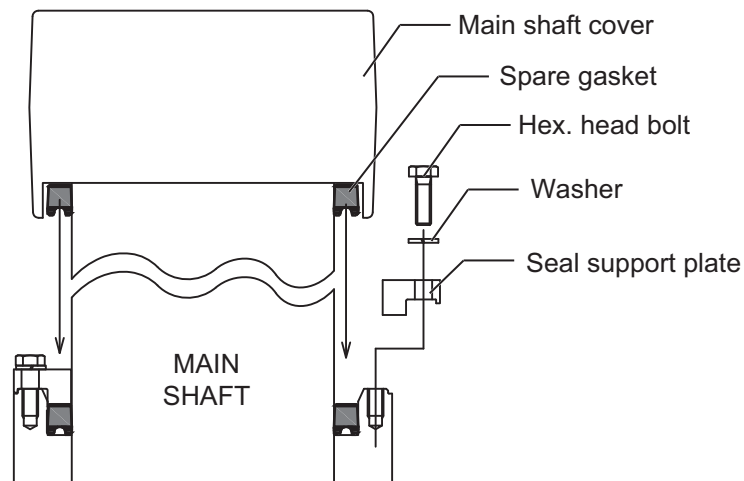

### 9.2.3 How to replace the anti-corrosion zinc plates

#### CAUTION

Replace the anti-corrosion zinc plates yearly.

Corrosion may result, allowing water leakage and/or loss of transducer.

The clearance between the hull and the ground or deck must be 650 mm or more.

1. Remove the silicone sealant covering the hex. head bolts.
2. Unfasten the hex. head bolts and then remove the washers (2 pcs.) and anti-corrosion zinc plates (6 pcs.).

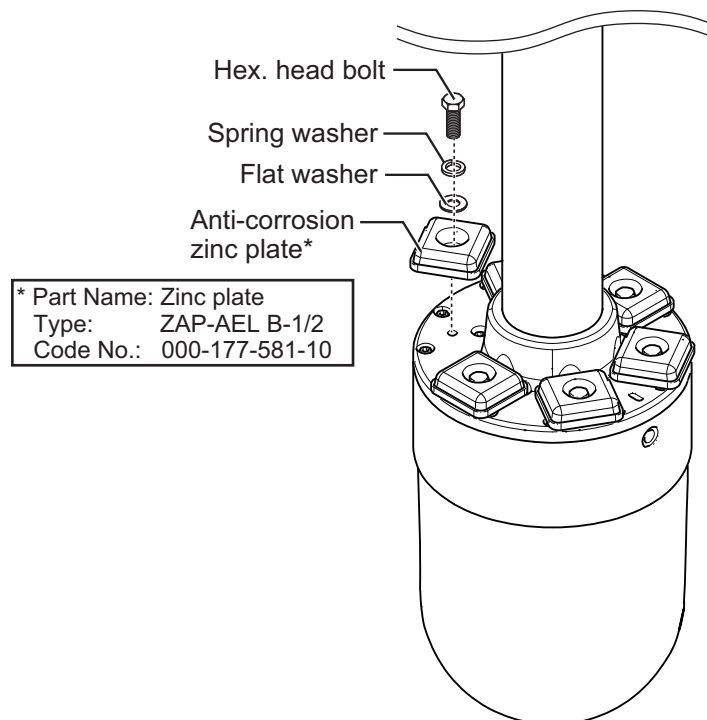

3. Set washers, new anti-corrosion zinc plates and hex. head bolts. Tighten the hex. head bolts.
4. Coat the holes for the hex. head bolts with silicone sealant.

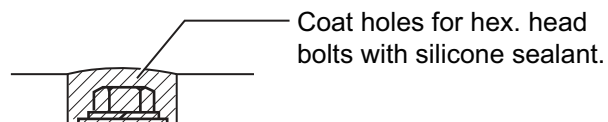

## 9.3 Battery on the Motherboard

The battery on the motherboard in the processor unit backs up data. When the voltage is too low, time and date may not display correctly. However, if the ZDA sentence (time and date data) is input from an external source, time and date are displayed according to the received data.

Name	Type	Code No.	Life
BATTERY KIT	BATTERY KIT-FJ	000-196-791-10	10 years

**Note 1:** When the voltage is 2.6V or less, the error code 322 appears. Have a qualified technician replace the battery.

**Note 2:** Dispose of the battery in accordance with local regulations. Tape the + and - terminals of the battery before disposal to prevent short circuit, which could cause a fire.

## 9.4 How to Replace Fuses

### WARNING

#### Use the proper fuse.

Use of the wrong fuse can cause fire or damage the equipment.

The processor unit, transceiver unit and hull unit carry fuses that protect the system from overvoltage and equipment fault. If the power cannot be applied, check the following.

- Check the fuse in the processor unit.
- Check the circuit breaker in the transceiver unit. (The breaker is behind the lid at the front-right bottom corner of the unit.)

Find the cause before replacing a fuse. If the fuse blows again after replacement, contact your dealer for advice.

Unit	Type	Code No.	Remarks
Processor unit	FGBO-A 125V 15A PBF	000-155-827-10	For 12 VDC
	FGBO-A 125V 7A PBF	000-164-965-10	For 24 VDC
Transceiver unit	FGBO 250V 20A	000-155-786-10	For 100/110/115 VAC (2 pcs.)
	FGBO-A 250V 10A PBF	000-155-839-10	For 220/230 VAC (2 pcs.)
Transceiver unit (B voltage power section)*	FGBO-A 250V 15A PBF	000-157-874-10	2 pcs.
Transceiver unit (DC power section)*	FGMB-A 250V 5A PBF	000-157-570-10	2 pcs.
Hull unit*	FGMB-A 250V 2A PBF	000-157-497-10	

\*: These fuses are located inside the equipment and may contain high voltage. Under no circumstances should these fuses be replaced by the user.



## 9.5 How to Clean and Replace the Filter

Clean the filter in the Transceiver Unit when it becomes dusty. Turn the power off, then remove the filter and clean it with water and a mild detergent. Rinse the filter, allow the filter to dry then return it to the Processor Unit and Transceiver Unit.

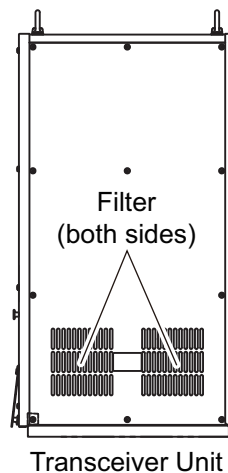

If the filter appears brittle and leaves residue on your hands when dry, replace the filter. For filter replacement, consult your local dealer and quote the following details:

Part name	Type	Code No.	Remarks
Dustproof Filter	10-086-6536	100-336-450-10	For Transceiver Unit

## 9.6 Trackball Maintenance

If the cursor moves abnormally, clean the trackball and inside the trackball housing (including the lens) as shown below:

1. Turn the retaining ring on the trackball module in the direction of the arrows (see figure below) to unlock it, then remove the retaining ring.

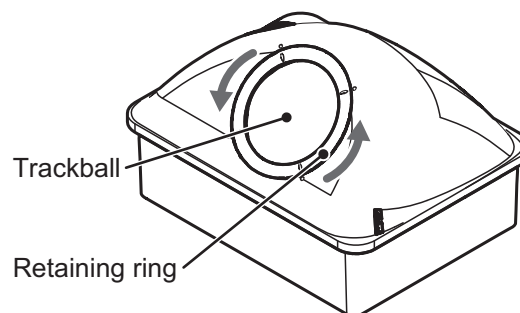

2. Use cellophane tape to remove the trackball from the trackball housing. Place the trackball and the retaining ring on a clean, soft cloth laid on a flat surface.
3. Clean the ball with a damp, soft cloth, then use a dry, lint-free cloth to carefully wipe the ball dry.
4. Use a swab, moistened with water, to carefully clean the inside of the retaining ring, the inside of the trackball housing, the supports and the lens. Change the

## 9. MAINTENANCE

swab regularly so that dirt and dust build-up is easily removed. Use a dry swab to wipe away moisture.

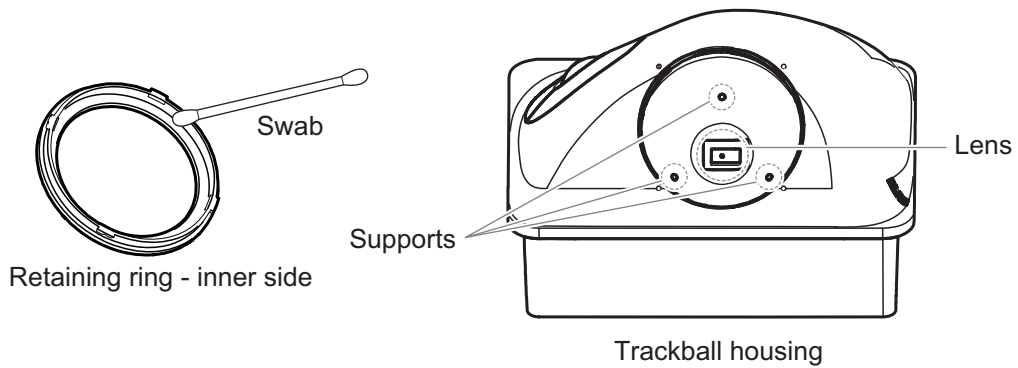

5. Re-set the ball and retaining ring. Be sure the retaining ring is not inserted reversely.

## 9.7 Troubleshooting

The table below provides common symptoms of equipment troubles and the means to rectify them. If the problem cannot be solved with the information supplied in this manual, consult your local dealer for service.

### Troubleshooting

Symptom	Check, remedy
Cannot turn on power	<ul style="list-style-type: none"> <li>• Check cables between transceiver unit, processor unit and monitor unit.</li> <li>• Check ship's mains.</li> <li>• Have a qualified technician check the fuses inside the transceiver unit.</li> </ul>
Cannot turn off power	<ul style="list-style-type: none"> <li>• Check cables between transceiver unit and processor unit.</li> <li>• Press and hold the power key for approximately seven seconds to force-shut-down the equipment.</li> </ul>
Cannot operate the equipment	<ul style="list-style-type: none"> <li>• Check connections between control unit and processor unit.</li> </ul>
Strange noise from hull unit	<ul style="list-style-type: none"> <li>• Gears may require re-greasing. See section 9.2.</li> </ul>
Bottom echo becomes irregular	<ul style="list-style-type: none"> <li>• Rough seas. Distance to the bottom changes due to rolling and pitching.</li> <li>• Long range selected. Transmission period is longer so ship's pitching and rolling are apt to affect detection of echo.</li> </ul>
Weak echoes	<ul style="list-style-type: none"> <li>• Output power set to minimum. Set power to maximum from main menu → [1 TX/RX Setting] → [3 Transmission Power].</li> <li>• Adjust the gain with the <b>GAIN</b> knob. See section 1.7.</li> <li>• If either near echoes or far echoes only are weak, adjust the [Near Gain] or [Far Gain] as appropriate. See section 2.6.</li> </ul>
Somewhat strange color	<ul style="list-style-type: none"> <li>• Brilliance setting too low. Increase the monitor brightness.</li> </ul>

<b>Symptom</b>	<b>Check, remedy</b>
Picture contains noise	<ul style="list-style-type: none"><li>• Equipment not grounded properly. Check equipment ground.</li><li>• Power cable is too close to the signal cable. Relocate power cable or signal cable.</li><li>• Debris may be on sea surface. Reject unwanted noise with the interference rejector on the [4 Picture Setting] menu or gain offset on the [3 Display Setting] menu.</li></ul>
Alarm releases no audio	<ul style="list-style-type: none"><li>• If settings at main menu → [9 Installation Setting] → [OK] → [1 Display Setting] → [2 Echo Display Area] are changed, on rare occasions the alarm is also silenced. Re-set the alarm parameters in this case.</li></ul>

## 9.8 Warning Messages

The table below shows the warning messages which may appear on the display. All warning messages are accompanied by a buzzer, which you may silence with the **R/B AUDIO** key.

### Warning messages

Message	Meaning, Remedy
<b>Power supply</b>	
<<OVERVOLTAGE!! >> RETRACT TRANSDUCER AND TURN OFF POWER. CHECK SHIP'S MAINS VOLTAGE. PRESS R/B KEY TO TURN OFF ALARM.	This message blinks at the screen center and the buzzer sounds when the voltage supplied to the transceiver unit is excessive. Transmission is stopped if the equipment is transmitting, to protect the transducer and transmitter power section from damage. →Silence the buzzer with the <b>R/B AUDIO</b> key, retract the transducer and turn off the power. Have a qualified technician check input voltage.
<b>Transceiver unit</b>	
<<NO RESPONSE FROM TRANSCEIVER UNIT!! >> TURN OFF AND ON POWER AGAIN, OR CHECK POWER LINE TO TRANSCEIVER UNIT. PRESS R/B KEY TO TURN OFF ALARM.	This message blinks at the screen center and the buzzer sounds when there is no reply from the transceiver unit. →Press the <b>R/B AUDIO</b> key to turn off the buzzer. Have a qualified technician check the set.
<<ELECTRIC CHARGE!! >>RETRACT TRANSDUCER AND TURN OFF POWER. CHECK SHIP'S MAINS VOLTAGE. PRESS R/B KEY TO TURN OFF ALARM.	This message blinks at the screen center and the buzzer sounds if the +B voltage of capacitors in the transceiver unit can not be charged to predetermined voltage within the specified time. →Press the <b>R/B AUDIO</b> key to silence the buzzer. Have a qualified technician check the set.
<<OVER TEMPERATURE!! >> RETRACT TRANSDUCER AND TURN OFF POWER. PRESS R/B KEY TO TURN OFF ALARM.	This message blinks at the screen center and the buzzer sounds when the temperature in the power supply block has exceeded 85°C; →Press the <b>R/B AUDIO</b> key to silence the buzzer. Turn off the system and have a qualified technician check the system.
<b>Hull unit, transceiver unit</b>	
<<TRANSDUCER NOT RETRACTED!! >>CUT OFF POWER LINE TO MONITOR UNIT AND HULL UNIT. PRESS R/B KEY TO TURN OFF ALARM.	This message blinks at the screen center, the buzzer sounds and the LEDs above keys blink if the transducer is not raised within 15 seconds (800 mm stroke) or 18 seconds (1100 mm stroke) after pressing the ↑ key. →Press the <b>R/B AUDIO</b> key to silence the buzzer. The reason may be the transducer is tangled in the net or its shaft is bent or the motor bleaker is off. Try raising it from the hull unit as shown in section 9.12.

Message	Meaning, Remedy
<<OVER TEMPERATURE!! >> RETRACT TRANSDUCER AND TURN OFF POWER. PRESS R/B KEY TO TURN OFF ALARM.	This message blinks at the screen center and the buzzer sounds when the temperature in the power supply block has exceeded 85°C; →Press the <b>R/B AUDIO</b> key to silence the buzzer. Turn off the unit and have a qualified technician check the set.
<<TRANSDUCER IS A HALT CONDITION!!>>TD IS A HALT CONDITION. CAN'T BE OPERATED UNTIL IT CANCELS. CHECK STOP BUTTON IS PUSHED OR TAKE OUT HULL UNIT RATCHET."	The hull unit is stopped because the emergency stop button in the hull unit was operated or the ratchet wrench in the hull unit was removed. →Press the <b>R/B AUDIO</b> key to silence the buzzer. Operate the emergency stop button and/or restore the ratchet wrench to enable raising, lowering operations.
<<TD RECOVERED THE HALT CONDITION!!>>TD RECOVERED THE HALT CONDITION. PRESS ↑↓ KEY, IF SAFETY IS ENSURED. PRESS THE R/B KEY TO CLOSE THE WINDOW.	The emergency stop condition at the hull unit was released. →Silence the buzzer with the <b>R/B AUDIO</b> key.
<<TD WRONG POSITION ALARM!!>> TRANSDUCER IS KEPT AT WRONG POSITION. SET BACK TRANSDUCER POSITION TO NORMAL BY USING ↑ KEY. PRESS R/B KEY TO TURN OFF ALARM.	This message blinks at the screen center and the buzzer sounds when the transducer is knocked out of position. →Try to return the transducer to its normal position by operating the ↑ key and silence the buzzer with the <b>R/B AUDIO</b> key.
<<SHIP SPD ALARM!!>>TRANSDUCER IS KEPT EXTENDED. MAX ALLOWABLE SPEED FOR EXTENDED TRANSDUCER IS 18 KT. PRESS R/B KEY TO TURN OFF ALARM.	This message blinks at the screen center and the buzzer sounds when the transducer is extended and ship's speed, input by external equipment, exceeds 18 knots. →Silence the buzzer with the <b>R/B AUDIO</b> key and lower ship's speed.
<<SHIP SPD ALARM!!>> MAX ALLOWABLE SPEED DURING RAISING/LOWERING TRANSDUCER IS 15 KT. PRESS R/B KEY TO TURN OFF ALARM.	This message blinks at the screen center and the buzzer sounds when the transducer is raised/lowered and ship's speed, input by external equipment, exceeds 15 knots. →Silence the buzzer with the <b>R/B AUDIO</b> key and lower ship's speed.

When multiple warnings occur at the same time, the warning with the highest priority is displayed. The order of priority is as follows:

Priority	Message	Remarks
1	<<TD IS A HALT CONDITION!!>>	Remains on-screen until the cause is removed or rectified.
2	<<TRANSDUCER NOT RETRACTED!! >>*	Remains on-screen until the cause is removed or rectified. After the cause is removed or rectified and restarts the unit, the message disappears.
3	<<OVERVOLTAGE!! >>	Remains on-screen until the cause is removed or rectified.
4	<<OVER TEMPERATURE!! (transceiver unit)>>	Remains on-screen until the cause is removed or rectified. After the cause is removed or rectified and restarts the unit, the message disappears.
5	<<OVER TEMPERATURE!! (hull unit, transceiver unit)>>	Remains on-screen until the cause is removed or rectified.

Priority	Message	Remarks
6	<<ELECTRIC CHARGE!! >>*	Remains on-screen until the cause is removed or rectified. After the cause is removed or rectified and restarts the unit, the message disappears.
7	<<NO RESPONSE FROM TRANSCEIVER UNIT!! >>	Remains on-screen until the cause is removed or rectified.

\*: These messages are not erased even if a message of higher priority arrives.

## 9.9 Error Codes

The equipment displays a (blinking) three-digit error code at the bottom of the display when it detects internal trouble. In case of multiple error, error codes appear in numerical order and the maximum number of error codes is five. The codes remain on the screen until the corresponding trouble is fixed, and a buzzer sounds each time a new error code is added to the on-screen error code display. For any error code, report error code number to your dealer.

\*\*\* Error Code \*\*\* #003, #006, #108

## 9.10 Status Messages

Status messages appear at the screen center to alert the operator. These are as below.

Status message	Meaning
TX Off	Transmission turned off from the menu. (main menu → [8 Test] → [9 Transmission]).
Unregistered	The transducer position is not registered and cannot be displayed on-screen. Consult your local dealer for register the transducer position.
Manually Testing Scan*	Scan/tilt command received from the control unit in normal operation, to manually test scan/tilt. <b>SCAN</b> and <b>TILT</b> controls on the control unit are inoperative during the hull unit test.

\*Not displayed when TX is OFF.

## 9.11 Tests

A comprehensive diagnostic facility is provided for testing the equipment. If NG (No Good) or abnormal display appears in the test results for any test, contact your dealer.

### 9.11.1 Test menu

1. Press the **MENU/ESC** key to show the main menu.
2. Select [Others] then push the left-click button.
3. Select [Initial Setting] then push the left-click button.
4. Select [Changeable] then push the left-click button.

5. Select [Test] then push the left-click button.

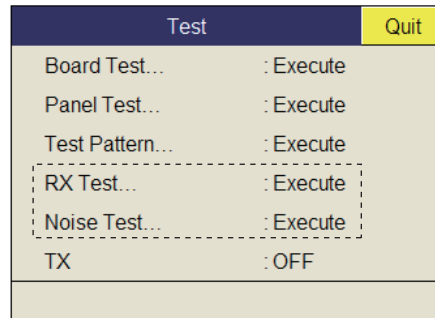

**Note:** The menu item [TX] turns transmission on/off. Turn off transmission to specify the source of noise, for example.

### 9.11.2 Board test

The board test checks all the circuit boards in the system. Select [Board Test] from the [Test] menu to do this test.

```

BOARD TEST
-----
Processor Unit  105-XXXX-01.01 ← (1)
                105-XXXX-01.01

                RAM = OK
                EWF = Enabled
                MAC Address = **_*_*_*_*_*_*_*_*_*_*_*_*_*_*_*
                IP Address = 192.*.*.*.*
                Subnet Mask = 255.255.*.*.*

                Monitor1 = --
                Monitor2 = --
                USB1 =
                USB2 =
                USB3 =
                USB4 =
                SSD = --
                CPU Temp = *.*.*C°
                Board Temp = *.*.*C°
                Battery = *.*.*V

Control Unit    105-XXXX-XX.XX ← (2)
                105-XXXX-XX.XX
                105-XXXX-XX.XX

                ROM = OK
                RAM = OK

TRCPU-0        105-0790-XX.XX
                105-0791-XX.XX
                S2 00000000 (00) ← (3)
                S3 00000000 (00)

                ROM = OK
                RAM = OK
                TDS = OK

TRX            0 0 0 0 0 F 0 0 0 0 0 0 0 0 0 0 ← (4)

BMF-0          DATA = OK
                RDS1 = OK      S1 00000000 (00) ← (5)
                RDS2 = OK      S2 00000000 (00)
                FDS1 = OK      S3 00000000 (00)
                FDS2 = OK      S4 00000000 (00)

PWR            12V = 12.2V
                +B = 120.5V

(6) → INC      TEST = OK
                PITCH = +12.3
                ROLL = - 2.5

TD             TEMP = 76.4C° ← *
                (7) → Position = 1450 mm (91)
                UP_LSW = 0 mm (0)
                HTX_SW = 1000 mm (62)
                DN_LSW = 1600 mm (100)

Control Unit   105-XXXX-XX.XX ← (8)
                105-XXXX-XX.XX
                105-XXXX-XX.XX

                ROM = OK
                RAM = OK

Press MENU/ESC key to cancel.
    
```

\*: Shown only when the **OFF CENTER** key is pressed.

OK: Normal, NG: Error  
XX: Version No.

For any NG, contact your dealer for advice.

#### How to read the test results

(1)	Program number for processor unit. (From top: OS program, application program)
(2)	Program number for control unit. (From top: starter program, boot program, application program)
(3)	Program number for TRCPU board and DIP switch setting (From top: SW program, FPGA program)
(4)	TRX board update number (numbered from left)
(5)	DIP switch setting for BMF board
(6)	Inertial measurement unit test results.
(7)	Transducer temperature. Press the <b>OFFCENTER</b> key to display.
(8)	Program number for No.2 control unit. (From top: starter program, boot program, application program)



### 9.11.3 Panel test

The panel test checks the keys, controls and trackball of the control unit. Select [Panel Test] from the [Test] menu to do this test.

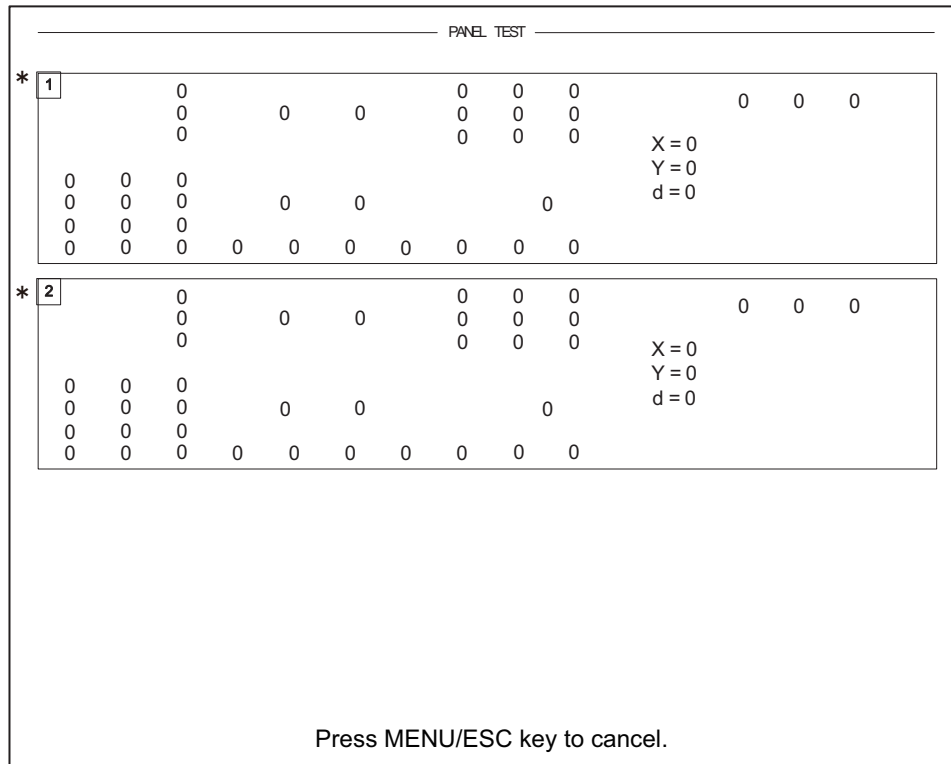

\*When two control units are connected, 1 is for main control unit and 2 is for sub control unit.

**Key check:** Press each key one by one. A key is normal if its corresponding on-screen location shows 1 while the key is pressed and 0 when the key is released. The power key (ON and OFF) can not be checked.

**Control check:** Operate each control one by one. A control is normal if;  
Clockwise rotation: Positive value  
Counterclockwise rotation: Negative value  
No rotation: "0"

**Lever check:** Press the lever upward or downward. Normal conditions are 1 for upward and 2 for downward.

**Trackball check:** Operate the trackball. X-Y coordinates of trackball position are displayed. Normal conditions are as follows.  
Rightward: X positive, Leftward: X negative  
Upward: Y positive, Downward: Y negative

### 9.11.4 Test pattern

The test pattern test checks for proper display of colors. Select [Test Pattern] from the [Test] menu to do this test. Use the **MODE** key to change the test pattern.

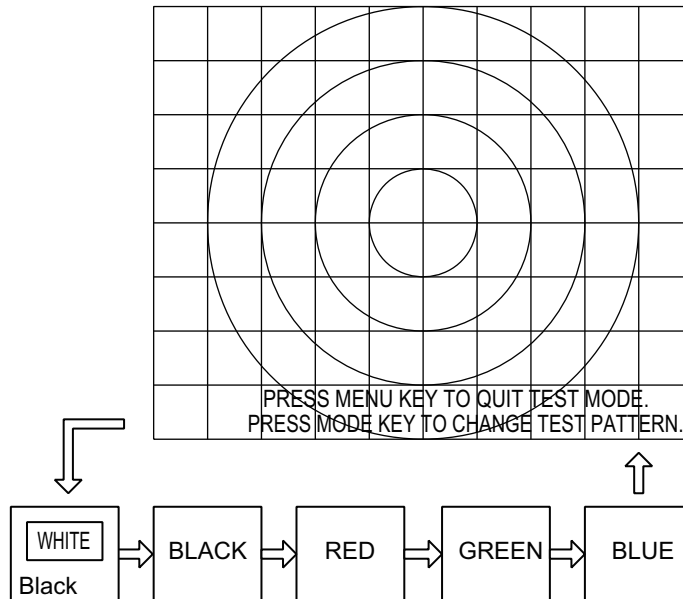

## 9.12 How to Raise the Transducer from the Hull Unit

If the transducer cannot be raised with the switches on the control unit, because it is tangled in the net or its shaft is bent, try to raise it from the hull unit, automatically or manually, whichever works.

This procedure is intended for the service technician.

### 9.12.1 How to raise the transducer automatically

If the message "TRANSDUCER NOT RETRACTED" appears, and the transducer cannot be retracted from the control unit, do as follows:

1. Check the LEDs on the hull unit.  
When the L.SW\_LED on the raise/lower control box flashes, the raise/lower function may be abnormal. Do the following steps to raise the transducer, then contact your dealer. When you can not check the LEDs, go to step 2.
2. Turn off the switchboard, transceiver unit and hull unit from the ship's mains breaker.  
To force a system shut-down, press and hold the POWER ON (I) switch for approx. 10 seconds.
3. Check if the net or other object is caught in the transducer.
4. Look through the lid on the raise/lower control box in the hull unit to check if the motor breaker is OFF. If it is midway between ON and OFF, open the lid and turn it off and then on.

**Note:** From Step 5 to Step 7 is procedure for service technician.

- Unfasten six screws to remove the cover of the raise/lower control box.

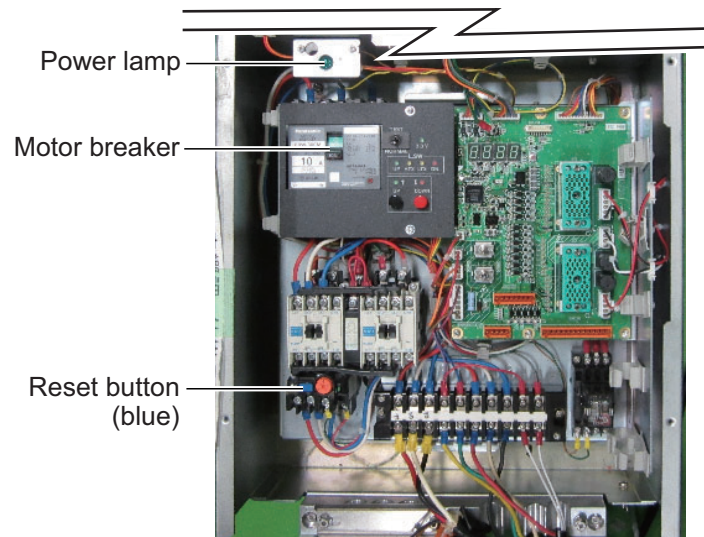

- Push the RESET button (green) on the raise/lower control box.

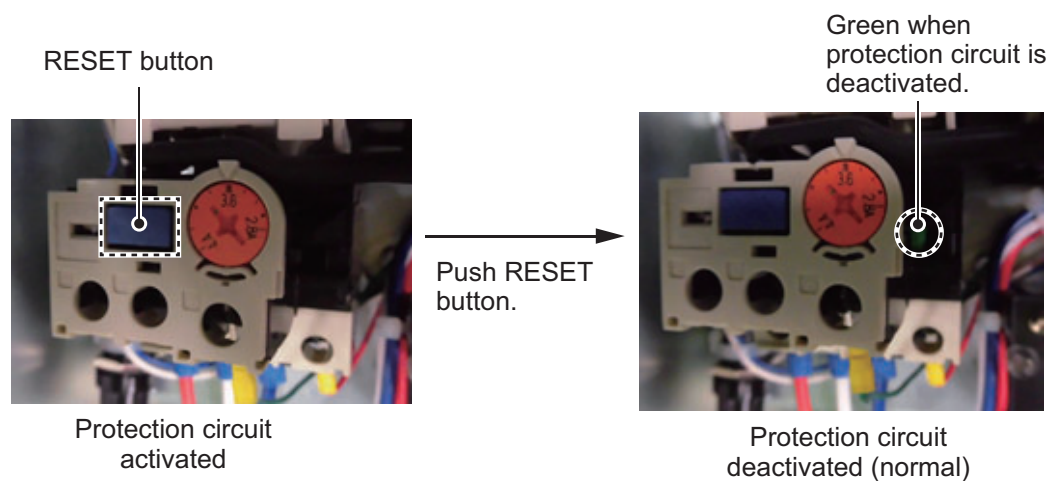

- Close the cover.
- Turn on the breaker at the ship's mains.  
If you force quit the system at step 1, go to the step 8.
- Turn on the system from the control unit.
- Press **↑** key to raise the transducer.

If the transducer cannot be raised, the shaft may be bent. In this case raise it manually with the ratchet wrench, following the instructions in the next section.

### 9.12.2 How to raise the transducer manually

**⚠ WARNING**

**!** Before operating the hull unit manually, check that the motor brake and shaft are working properly.

1. Open the lid on the raise/lower control box of the hull unit and turn off the motor breaker. Confirm that the power lamp is off. (See the illustration on the previous page for the location of those parts.)
2. Unscrew the butterfly bolts, then move the motor shaft cover.
3. Attach the ratchet wrench to the motor shaft.
4. While holding the ratchet wrench, pull the release lever toward you and upward to release the brake.

**Note:** Hold the ratchet wrench when releasing the brake, to prevent the transducer from falling.

5. Turn the ratchet wrench counter-clockwise to raise the transducer.
6. After retracting the transducer into the tank, set the release lever to the holder.
7. Remove the ratchet wrench and return it to its holder. Restore the motor brake to its normal position.

**Note:** Be sure to return the ratchet wrench to its holder. Otherwise the hull unit will be stopped and the transducer cannot be raised or lowered.

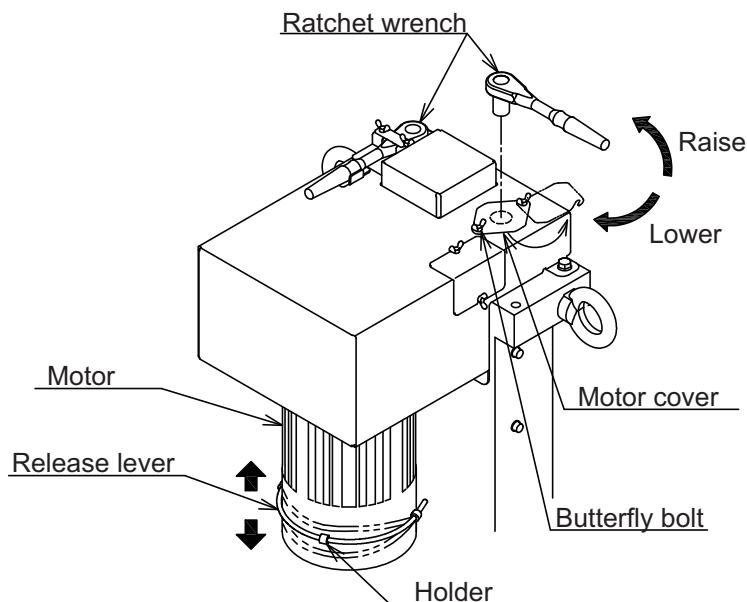

## 9.13 How to Check the Brake in the Hull Unit

The main shaft in the hull unit has two brakes, motor brake and drive shaft brake. Have a qualified technician check the brakes yearly.

**Before doing the check, make sure no one is near the hull unit and transducer.**

**Note:** Record the check result in the brake check sheet at appendix 2.

### 9.13.1 How to check the brake in the raise/lower control box

1. Unfasten six screws to remove the cover from the raise/lower control box in the hull unit.

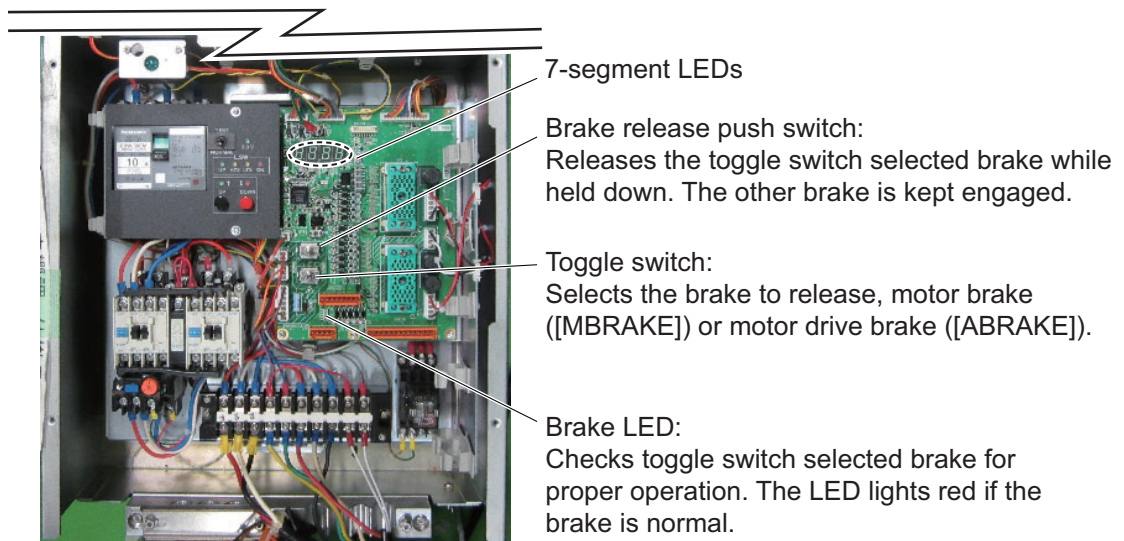

2. Set the toggle switch to the ([MBRAKE]) side.
3. Check that the Brake LED on the circuit board is lit. The LED does not light when the motor break control circuit is abnormal. If the LED is OFF, return the toggle switch to its original position and contact your dealer for advice.
4. Set the toggle switch to the [MBRAKE] position. Hold down the brake release push switch to release the motor brake. Check that the main shaft does not lower and the 7-segment LEDs on the circuit board does not change. If the main shaft lowers or the LED lighting pattern changes, release the brake release push switch. The drive shaft brake is abnormal; check the drive shaft brake.
5. Set the toggle switch to the ([ABRAKE]) side.
6. Check that the Brake LED on the circuit board is lit. The LED does not light when the drive shaft gear brake control circuit is abnormal. If the LED is OFF, return the toggle switch to its original position and contact your dealer for advice.
7. Hold down the brake release push switch to release the drive shaft gear. Check that the main shaft does not lower and the 7-segment LEDs on the circuit board does not change. If the main shaft lowers or the LED lighting pattern changes, release the brake release push switch. The motor brake is abnormal; check the motor brake.

### 9.13.2 How to measure the gap in the motor brake

1. Use cir-clip pliers to release the two C-clips (one to either side of the brake).

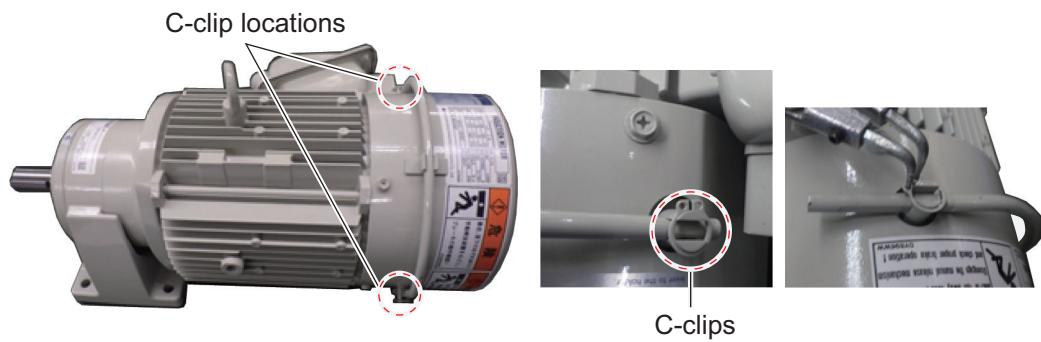

2. Pull the brake release lever to unlock the brake.

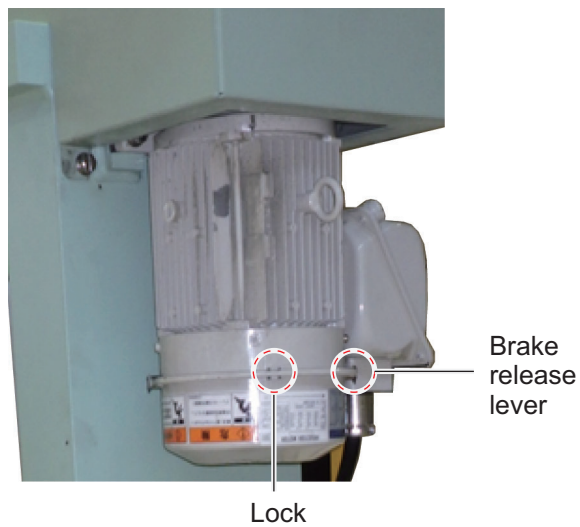

3. Remove the brake release level with a set of pliers.



4. Remove the brake release lever pin with a pair of pliers.





5. Unfasten three bolts to remove the brake cover.

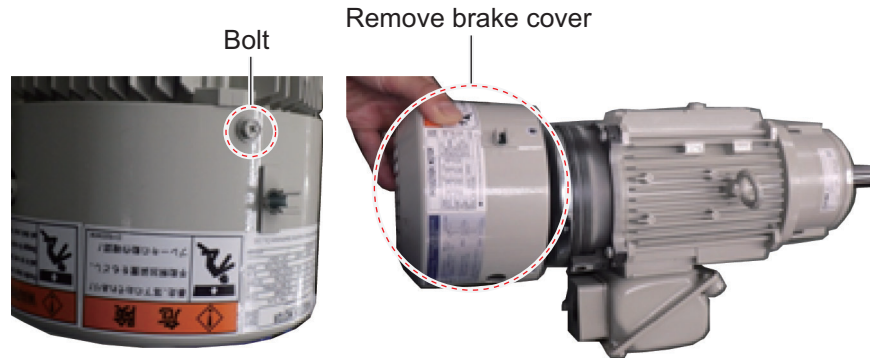

6. Unfasten the fan bolt, then remove the fan.

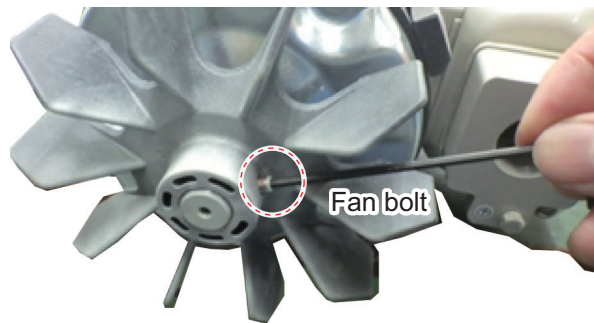

7. Unfasten both release plates (one on either side) with a hex wrench, then remove the plates.



8. Referring to the following figure, unfasten the three screws, then remove the waterproofing cover and washer.

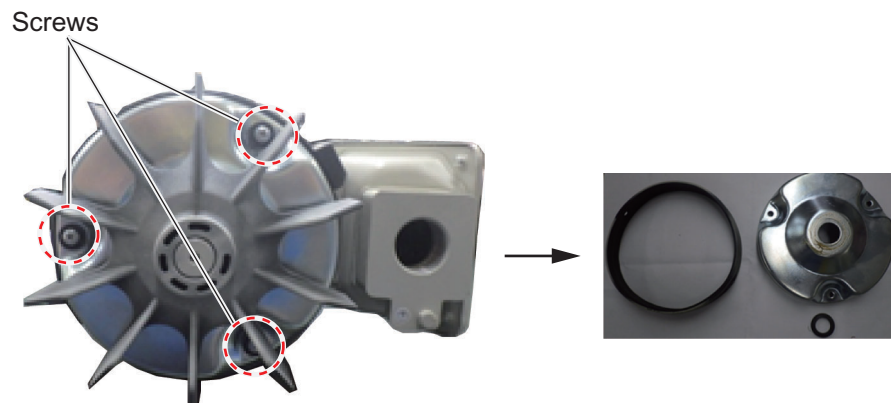

## 9. MAINTENANCE

9. Use a gap gauge to measure the gap between the fixed core and the moving core.

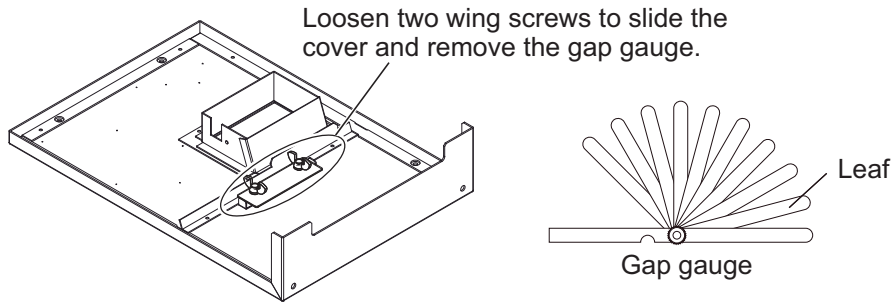

Insert the leaf of the gap gauge horizontally to the place of measurement. Take the measurement. Measure the gap at three places.

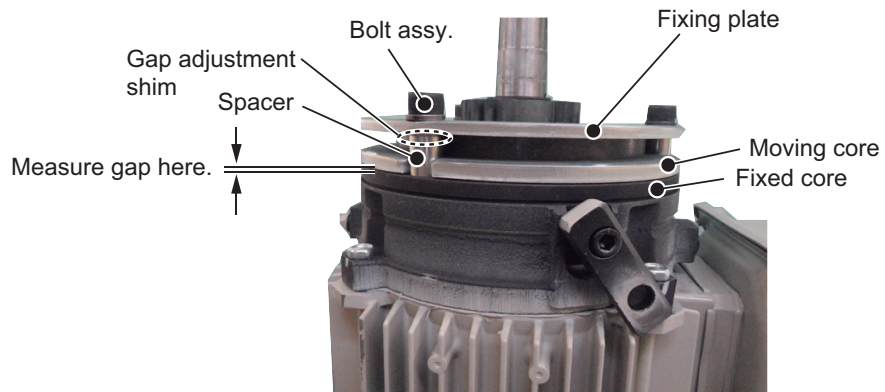

10. If the gap measured at step 9 is approx. 0.6 mm, do the following to reduce the gap. (If you can insert the 0.6 mm leaf, do steps 1) to 3) below.)

- 1) Loosen three hex bolts to remove spacer, gap adjustment shim, bolt assembly, and fixing plate.

**Note:** Be careful not to drop the gap adjustment shim.

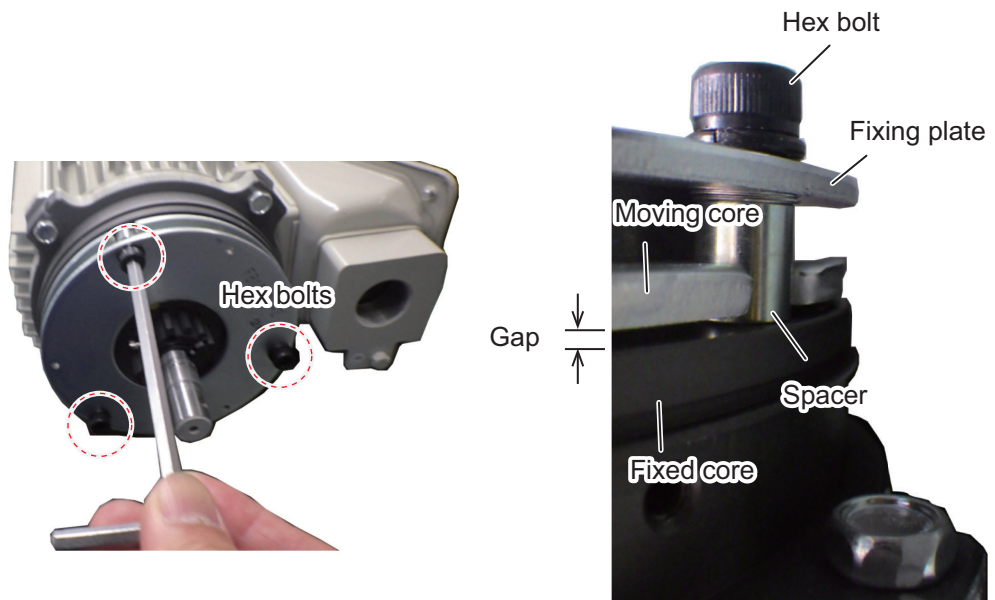



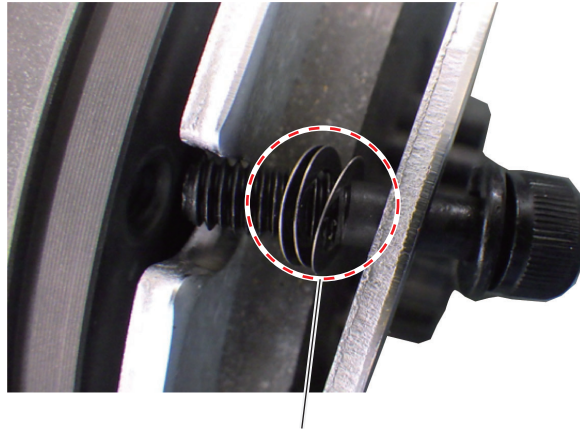

There is a chance to drop the shim when you remove the spacer.  
Be sure to catch the shim when performing this operation.

- 2) Reduce the amount of gap adjustment shims (thickness of shim: approx. 0.2 mm), then install the spacer, gap adjustment shim, bolt assembly and fixing plate.
  - 3) Measure the gap. The gap must be between 0.3 and 0.4 mm. (Confirm that the 0.3 mm leaf can be inserted, but the 0.4 mm leaf cannot.)
11. Reassemble the motor brake.

**Note 1:** Coat the hex bolt for the fan with thread-locking fluid.

**Note 2:** Make sure that the holes on the release plates (removed at step 7) are aligned with the holes on the waterproofing washer and the release plate fixing holes. If the locking pins do not fit easily, the holes may be mis-aligned. Check the alignment and re-align as necessary.

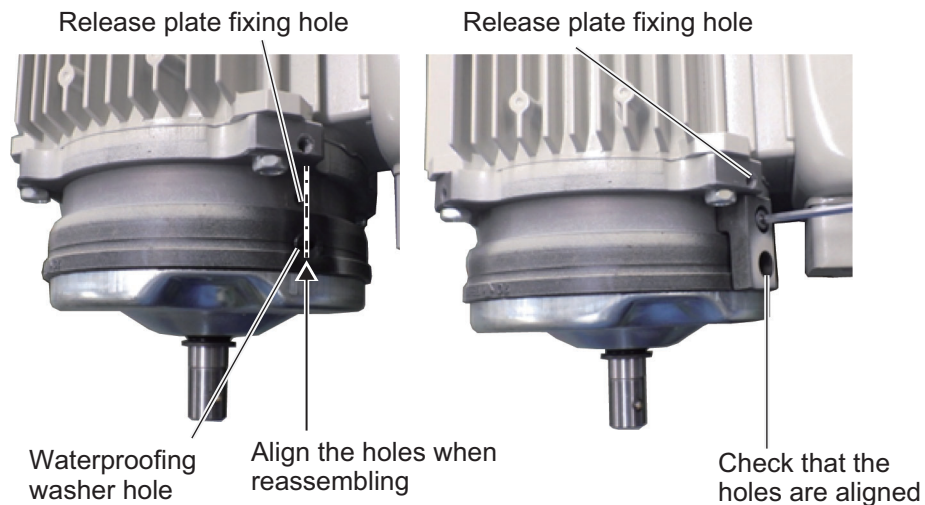

This page is intentionally left blank.

# APPENDIX 1 MENU TREE

Main menu

Default: ***Bold Italic***

- └ TX/RX Setting    **1** (Page AP-1)
- └ Gain Setting    **2** (Page AP-1)      **U: Items which can be**
- └ Display Setting **3** (Page AP-2)      **programmed to the user menu.**
- └ Picture Setting **4** (Page AP-2)
- └ Others            **5** (Page AP-2 to AP-5)    **F: Items which can be programmed**
- └ Shortcut Menu    **6** (Page AP-6)            **to a function key.**

## 1 TX/RX Setting U: No/F: Yes

- └ TX Interval (External KP, 1 to 9; **9**) [H1/H2/S], U: Yes/F: Yes
- └ TX Pulse Length (0 to 9; **7**) [H1/H2/S/V], U: Yes/F: Yes
- └ TX Power (0 to 9; **9**) [H1/H2/S/V], U: Yes/F: Yes
- └ Frequency, U: No/F: Yes
  - └ Freq Shift1 (-65 to 65; **0**)
    - └ [H1/H2/S/V], U: Yes/F: Yes
  - └ Freq Shift2 (-65 to 65; **0**)
    - └ [H1/H2/S/V], U: Yes/F: Yes
  - └ Freq/Bearing Set (0 to 358°; **0°**) [H1/H2], U: Yes/F: Yes
- └ Sidelobe Sup., U: No/F: Yes
  - └ Sidelobe Sup.A (-3 to 4; **3**) [H1/H2/S], (-3 to 3; **3**) [V], U: Yes/F: Yes
  - └ Sidelobe Sup.B (-5 to 5; **0**) [H1/H2/S/V], U: Yes/F: Yes
  - └ Sidelobe Dir1 (0 to Sidelobe Dir2; **60°**) [H1/H2/S], U: Yes/F: Yes
    - └ Sidelobe Dir2 (Sidelobe Dir1 to 180°; **120°**) [H1/H2/S], U: Yes/F: Yes
- └ Reverberation (0 to 3; **0**) [H1/H2/S/V], U: Yes/F: Yes
- └ Beam Width, U: No/F: Yes
  - └ Beam Control (**Manual**, Range, Tilt) [H1/H2/S], (**Manual**, Range) [V],
    - └ U: Yes/F: Yes
  - └ TX Beam Width (-4 to 3; **0**) [H1/H2/S/V], U: Yes/F: Yes
  - └ Hor. RX Beam Wid (-4 to 3; **0**) [H1/H2/S/V], U: Yes/F: Yes
  - └ Ver. RX Beam Wid (-4 to 3; **0**) [H1/H2/S/V], U: Yes/F: Yes
  - └ RX Beam Control (0 to 3; **0**) [H1/H2/S/V], U: Yes/F: Yes

## 2 Gain Setting U: No/F: Yes

- └ TVG-Near (-5 to 5; **5**) [H1/H2/S/V], U: Yes/F: Yes
- └ TVG-Medium (-5 to 5; **4**) [H1/H2/S/V], U: Yes/F: Yes
- └ TVG-Far (-5 to 5; **2**) [H1/H2/S/V], U: Yes/F: Yes
- └ TVG Distance [H1/H2/S/V], U: No/F: No
- └ Sel. TVG Curve (TVG 1, TVG 2, **TVG 3**, TVG 4) [H1/H2/S/V], U: Yes/F: Yes
- └ AGC (-20 to 20; **0**) [H1/H2/S/V], U: Yes/F: Yes
- └ Near AGC, U: No/F: Yes
  - └ Near AGC (-20 to 20; **2**) [H1/H2/S/V], U: Yes/F: Yes
    - └ Near AGC Distance (20 to 2000 m; **100m**) [H1/H2/S/V], U: Yes/F: No
- └ 2nd AGC, U: No/F: Yes
  - └ 2nd AGC (0 to 20; **5**) [H1/H2/S/V], U: Yes/F: Yes
  - └ Distance (0 to 2000 m; **60m**) [H1/H2/S/V], U: Yes/F: No
  - └ Type (**Normal**, Pre Only, Post Only) [H1/H2/S/V], U: Yes/F: No
  - └ Post2nd AGC-Near (0 to 20; **0**) [H1/H2/S], U: Yes/F: Yes
  - └ Post2nd AGC-Far (0 to 20; **0**) [H1/H2/S], U: Yes/F: Yes
  - └ Post2nd AGC Dist (0 to 2000 m; **0 m**) [H1/H2/S], U: Yes/F: Yes
    - └ Exclusive Rng S ( $\pm 0$  to  $\pm 90$ ;  **$\pm 0$** ) [H1/H2], U: Yes/F: Yes
- └ Absorption Coeff.(AUTO, 0.0 to 32.0 dB; **27.5dB**)
  - └ [H1/H2/S/V] U: Yes/F: Yes
- └ Gain Control (Normal, **Wide**) [H1/H2/S/V], U: Yes/F: Yes

Continued on next page

Continued from previous page

**3 Display Setting U: No/F: Yes**

- └ Noise Limiter (0 to 15; **7**) [H1/H2/S/V], U: Yes/F: Yes
- └ Gain Offset (-24 to 12; **5**) [H1/H2/S/V], U: Yes/F: Yes
- └ Signal Level (0 to 15; **3**) [H1/H2/S/V], U: Yes/F: Yes
- └ Color (Color 1, **Color 2**, Color 3, Color 4) [H1/H2/S/V], U: Yes/F: Yes
- └ H-Scan Color Setting [H1/H2/S/V], U: No/F: No
- └ S-Scan Color Curve Setting [H1/H2/S/V], U: No/F: No

**4 Picture Setting U: No/F: Yes**

- └ Echo Average (0 to 7; **2**) [H1/H2/S/V], U: Yes/F: Yes
- └ Int Reject (0 to 3; **0**) [H1/H2/S/V], U: Yes/F: Yes
- └ Smooth Echo RNG (0 to 7; **3**) [H1/H2/S/V], U: Yes/F: Yes
- └ Smooth Echo CIR (0 to 5; **1**) [H1/H2/S/V], U: Yes/F: Yes
- └ A-Train Echo Average (0 to 7; **2**) [S], U: Yes/F: Yes
- └ A-Train Int Reject (0 to 3; **0**) [S], U: Yes/F: Yes

**5 Others U: No/F: Yes**

- └ Erase Marks U: No/F: Yes
  - └ Event Mark1 (Execute), U: Yes/F: Yes
  - └ Event Mark2 (Execute), U: Yes/F: Yes
  - └ Fish Mark1 (Execute), U: Yes/F: Yes
  - └ Fish Mark2 (Execute), U: Yes/F: Yes
  - └ Own Ship Pos Mark (Execute), U: Yes/F: Yes
  - └ Ship's Track (Execute), U: Yes/F: Yes
- └ Wheel Setting U: No/F: Yes
  - └ H Mode (**Tilt Angle**, Range, Gain), U: Yes/F: Yes
  - └ S Mode (**Tilt Angle**, Range, Gain, Turn Angle), U: Yes/F: Yes
  - └ V Mode (Range, Gain, **Bearing**), U: Yes/F: Yes
  - └ Wheel (Normal, **Reverse**), U: Yes/F: Yes
- └ Mid Key Setting (**Fixed Potision**, Any Position) U: No/F: No
- └ Display Setting U: No/F: Yes
  - └ TX/RX Mode (**Alternative**, Multi), U: Yes/F: Yes
  - └ Mode Selection (**Mode Key**, Pull-Down Menu), U: No/F: No
  - └ Echo Disp Area (**Within Range**, Full Screen), U: Yes/F: Yes
  - └ H2/S Display (**Landscape**, Portrait, Inset), U: Yes/F: Yes
  - └ 2nd Monitor Setting (**Portrait**, Landscape), U: Yes/F: Yes
  - └ V-Scan Aspect Ratio (**Fixed**, Flexible), U: Yes/F: Yes
  - └ V-Scan Dpt Rng (20, 40, 60, 80, **100**), U: Yes/F: Yes
  - └ Presentation Mode (**Head Up**, North Up, Course Up, True Motion), U: Yes/F: Yes
  - └ TM Disp Range (1.3R, **1.6R**), U: No/F: No
  - └ Full Screen Area (1.3R, **1.6R**), U: No/F: No
  - └ Bearing Ref (**Ship Heading**, North), U: No/F: Yes
  - └ TILT lever (**Tilt**, Tilt&V), U: No/F: No
  - └ Auto Tilt (Wide, **Narrow**), U: No/F: No
  - └ S Auto Off Cent (**OFF**, 30°, 45°, 60°) U: No/F: No
  - └ Net Course Mark (**Execute**, Delete), U: No/F: Yes
  - └ Dimmer (0 to 15; **7**), U: Yes/F: Yes
  - └ Key Beep Volume (0 to 7; **5**), U: No/F: No
  - └ Timer Display (**OFF**, ON), U: No/F: No
  - └ Disp. Hull Unit Status (OFF, **ON**), U: No/F: No
- └ Alarm & Audio U: No/F: Yes
  - └ Fish Alarm (**OFF**, ON), U: No/F: No
  - └ Alarm Level (0 to 30; **16**), U: No/F: No
  - └ Alarm Zone, U: No/F: No
  - └ Ship SPD Alarm (OFF, **ON**), U: No/F: No
  - └ Audio (OFF, **ON**), U: No/F: No
  - └ Audio Volume, U: No/F: No
  - └ Audio Sector (30°, 60°, 90°, 180°, 330°), U: No/F: No
  - └ Reverberation (0 to 9; **0**), U: No/F: No

Continued on next page

*Continued from previous page*

- └ Register U: No/F: Yes
  - | └ Display Mode (**H1** , S, **H1&H2** , H&S, **V1** , **V1&V2**), U: No/F: No
  - | └ Sel User Prog (**H/V Interlock** , H/V Individual), U: No/F: No
  - | └ Assign User Prog (P1 to P10), U: No/F: No
  - | └ Assign User Prog-H/S (P1-H/S to P10-H/S), U: No/F: No
  - | └ Assign User Prog-V (P1-V to P10-V), U: No/F: No
  - | └ Auto User Prog Sel (**OFF**, ON), U: No/F: No
  - | └ Auto User Prog (P1 to P10), U: No/F: No
  - | └ Auto User Prog-H/S (P1-H/S to P10-H/S), U: No/F: No
  - | └ Auto User Prog-V (P1-V to P10-V), U: No/F: No
  - | └ F-KEY List, U: No/F: No
  - | └ Clear F-KEYSetting (F1 to F10), U: No, F: No
  - | └ H-Scan Range (60 to 2000 m; 100 m, 200 m, 400 m, 600 m, 800 m, 1000 m), U: No/F: No
  - | └ S-Scan Range (60 to 2000 m; 100 m, 200 m, 400 m, 600 m, 800 m, 1000 m), U: No/F: No
  - | └ V-Scan Range (60 to 2000 m; 100 m, 200 m, 400 m, 600 m, 800 m, 1000 m), U: No/F: No
  - └ Remote Key Setting U: No/F: No
    - | └ Ch1 (**Tilt Up** , Tilt Down, Range Up, Range Down, Gain Up, Gain Down, User Prog Up, User Prog Down, Retract, Half-Protrude, Full-Protrude, Event Mark1, Event Mark2, Fish Mark1, Fish Mark2, Estimate Mark1, Estimate Mark2, Net Shoot Mark, Target Lock, Erase Marks, Auto Tilt, Tilt Reset, Display Mode, Off Center, Range/Bearing, F1 to F10, Sweep Right, Sweep Left, Auto Sweep, Sweep Reset,
    - | └ Ch2 (Same as Ch1; **Tilt Down**) (S: No; F: No)
    - | └ Ch3 (Same as Ch1; **Range Up**) (S: No; F: No)
    - | └ Ch4 (Same as Ch1; **Range Down**) (S: No; F: No)
    - | └ Ch5 (Same as Ch1; **Gain Up**) (S: No; F: No)
    - | └ Ch6 (Same as Ch1; **Gain Down**) (S: No; F: No)
    - | └ Ch7 (Same as Ch1; **User Prog Up**) (S: No; F: No)
    - | └ Ch8 (Same as Ch1; **User Prog Down**) (S: No; F: No)
    - | └ Ch9 (Same as Ch1; **Display Mode**) (S: No; F: No)
    - | └ Ch10 (Same as Ch1; **Off Center**) (S: No; F: No)
- Record/Recall U: No/F: Yes
  - | └ Still Image, U: Yes/F: Yes
  - | └ Setting File, U: No/F: Yes
    - | | └ Save, U: No/F: No
    - | | └ Load, U: No/F: No
      - | | | └ Load User Prog., U: No/F: No
  - | └ Delete Data, U: No/F: No
  - | └ Destination To Save, U: No/F: No
  - | └ Record Still Image (Execute), U: No/F: Yes
  - | └ Recall Still Image (Display), U: No/F: Yes
  - └ Initial Setting U: No/F: Yes
    - | └ TVG Monitor Transp. (**OFF**, ON)
    - | └ Monitor Setting, U: No/F: Yes
      - | | └ Monitor Orientation (**Horizontal**, Vertical) U: Yes/F: Yes
      - | | └ 2nd Monitor Setting (OFF, **Dual Display**, Sub Display), U: Yes/F: Yes
        - | | | └ Monitor Resolution (**SXGA**, UXGA, WUXGA), U: Yes/F: Yes
    - | └ Data Display, U: No/F: Yes
      - | | └ Data Display (**ON**, OFF), U: Yes/F: Yes
    - | └ Mark Display, U: No/F: Yes
      - | | └ Heading Mark (OFF, **ON**), U: No/F: No
      - | | └ Range Rings (OFF, **ON**), U: No/F: No
      - | | └ Bearing Scale (OFF, **Coarse**, Fine), U: No, F: No
      - | | └ Own Ship's Track Plot (OFF, **ON**), U: No/F: No
      - | | └ Data On Track (**OFF**, Water Temp, Water Depth), U: No/F: No
      - | | └ Net Move Plot (OFF, **ON**), U: No/F: No
      - | | └ Fish Mark Connect (OFF, **ON**), U: No/F: No
      - | | └ Target Vector (OFF, **ON**), U: No/F: No
      - | | └ Fish Track Plot (OFF, **ON**), U: No/F: No
      - | | └ EVENT Key (**Event**, Shoot), U: No/F: No
      - | | └ Histogram Disp. (OFF, **ON**), U: No/F: No
      - | | └ Mark Color (**White**, Baby blue, Blue, Yellow, Purple, Green),
        - | | | └ Transducer Position Mark (OFF, **ON**), U: No/F: No

*Continued on next page*

## APPENDIX 1 MENU TREE

*Continued from previous page*

- └ Mark Size, U: No/F: Yes
  - └ Trackball Mark (**+Small**, +Large, ■ Small, ■ Large), U: No/F: No
  - └ Target Lock Mark (**Normal**, Small, Large), U: No/F: No
  - └ Target Vector (Short, **Small**, Long), U: No/F: No
  - └ Event Mark (Normal, Small, **Large**), U: No/F: No
  - └ Fish Mark (Normal, Small, **Large**), U: No/F: No
  - └ Own Ship Pos Mark (**Normal**, Large, Small), U: No/F: No
  - └ Own Ship Mark (Standard, Large, **Actual**), U: No/F: No
  - └ Net Shoot Mark (**Normal**, Large, Small), U: No/F: No
  - └ Estimate On Scan (Small, **Large**), U: No/F: No
  - └ Current Vector (**Small**, Long, Short/Thick, Long/Thick), U: No/F: No
  - └ Range Ring Interval (1/2R, **1/4R**, Auto), U: No/F: No
  - └ Bearing Scale (**Small**, Large), U: No/F: No
    - └ Own Ship's Track Plot (**5R**, 10R, 20R, 40R), U: No/F: No
- └ Data Display, U: No/F: Yes
  - └ Range&Bearing (OFF, **ON**), U: No/F: No
  - └ Fishing Area (**OFF**, ON), U: No/F: No
  - └ Cursor Position (**OFF**, ON), U: No/F: No
  - └ Course (**32 CMPS**, 360°True, 360°, ±180°), U: No/F: No
  - └ Current Data (32 CMPS, **360°True**, 360°, ±180°), U: No/F: No
  - └ Event Mark (**32 CMPS**, 360°True, 360°, ±180°), U: No/F: No
  - └ Other Marks (32 CMPS, 360°True, 360°, **±180°**), U: No/F: No
  - └ Distance For Shoot (**NM**, Meter, Feet), U: No/F: No
  - └ Water Temp (°C, °F), U: No/F: No
    - └ Water Temp Range (20 Minute, 1 Hour, 6 Hours, 12 Hours, 24 Hours), U: No/F: No
- └ Current Vec & Wind, U: No/F: Yes
  - └ Current Data (**Water Current**, Rel to Layer1, Rel to Layer2, Rel to Layer3, Rel to Layer4, Rel to Layer5), U: No/F: Yes
  - └ On Own Ship Mark (OFF, **ON**), U: No/F: No
  - └ On Ship Pos Mark (OFF, **ON**), U: No/F: No
  - └ On Net Shoot Mark (OFF, **ON**), U: No/F: No
  - └ Current Flow Dir (**To**, From), U: No/F: No
  - └ Wind (**OFF**, Relative, Absolute), U: No/F: Yes
    - └ Select Water Current (**Layer1**, **Layer2**, **Layer3**, Layer4, Layer5), U: No/F: Yes
- └ Net SONDE Setting, U: No/F: Yes
  - └ Number Of XMTR (0 to 10; **3**), U: No/F: No
  - └ XMTR Distance, U: No/F: No
    - └ End Of Net To S1 (0 to 1000 m; **400 m**), U: No/F: No
    - └ S1->S2 (0 to 1000 m; **400 m**), U: No/F: No
    - └ S2->S3 (0 to 1000 m; **400 m**), U: No/F: No
    - └ S3->S4 (0 to 1000 m; **400 m**), U: No/F: No
    - └ S4->S5 (0 to 1000 m; **400 m**), U: No/F: No
    - └ S5->S6 (0 to 1000 m; **400 m**), U: No/F: No
    - └ S6->S7 (0 to 1000 m; **400 m**), U: No/F: No
    - └ S7->S8 (0 to 1000 m; **400 m**), U: No/F: No
    - └ S8->S9 (0 to 1000 m; **400 m**), U: No/F: No
    - └ S9->S10 (0 to 1000 m; **400 m**), U: No/F: No
  - └ Net Length\* (500 to 3000 m; **1800 m**), U: No/F: No
    - └ **\* The minimum setting range for net length varies, depending on the settings for [Number of XMTR] and [XMTR Distance].**
  - └ Depth Display (S1 to S10; **S1 to S3**), U: No/F: No
  - └ Display Style (**Numeric**, Graph), U: No/F: No
    - └ Depth Graph Range (50 m, **100 m**, 150 m, 200 m), U: No/F: No
- └ Net Shoot Setting, U: No/F: Yes
  - └ Net Diameter (200 to 1000 m, **500 m**), U: No/F: No
  - └ Tilt Interlock (OFF, **ON**), U: No/F: No
  - └ Net Plot Corr-LYR1 (0 to 100%; **50%**), U: No/F: No
  - └ Net Plot Corr-LYR2 (0 to 100%; **50%**), U: No/F: No
  - └ Net Plot Corr-LYR3 (0 to 100%; **50%**), U: No/F: No
  - └ Net Plot Corr-LYR4 (0 to 100%; **50%**), U: No/F: No
  - └ Net Plot Corr-LYR5 (0 to 100%; **50%**), U: No/F: No

*Continued on next page*

*Continued from previous page*

- └ Target Lock, U: No/F: Yes
  - | └ Tracking Method (Target Mark, **Fish**), U: Yes/F: Yes
  - | └ Tilt Interlock (OFF, Tilt, **Tilt&Range**), U: No/F: No
  - | └ Mark Interlock (OFF, **Estimate Mark**, Est&Fish Info), U: No/F: No
  - | └ Tracking Data (Horizontal/S, **H&V**), U: No/F: No
  - | └ Threshold (1 to 30; **16**), U: No/F: No
  - | └ Bottom Threshold (0 to 5; **3**), U: No/F: No
  - | └ Target Speed Limit (1 to 15 kn; **5 kn**), U: No/F: No
  - | └ Smoothing (0.0 to 1.0; **0.5**), U: No/F: No
  - | └ Target SPD Update (15Sec, 30Sec, 45Sec, **60Sec**), U: No/F: No
  - | └ Target Lock Window (**Small**, Large, Largest), U: No/F: No
  - | └ Dimension Setup (0 to 100t/1000 m<sup>2</sup>; **25t/1000 m<sup>2</sup>**), U: No/F: No
  - | └ Volume Setup (0 to 100t/1000 m<sup>3</sup>; **25t/1000 m<sup>3</sup>**), U: Yes/F: No
- └ Stabilization, U: No/F: Yes
  - | └ Stabilization (OFF, **ON**), U: No/F: Yes
  - | └ Pitch Angle Cor (-10.0 to +10.0; **0.0**), U: No/F: No
  - | └ Roll Angle Cor (-10.0 to +10.0; **0.0**), U: No/F: No
  - | └ Sensor (**Standard**, GPS Gyro), U: No/F: No
- └ Test, U: No/F: Yes
  - | └ Board Test (Execute), U: No, F: No
  - | └ Panel Test (Execute), U: No, F: No
  - | └ Test Pattern (Execute), U: No, F: No
  - | └ RX Test (Execute), U: No, F: No
  - | └ Noise Test (Execute), U: No, F: No
  - | └ TX (**OFF**, ON, ON (Any Position)), U: Yes/F: Yes
- └ Initialization, U: No/F: Yes
  - | └ Save Ship's Org (Execute), U: No, F: No
  - | └ Recall Ship's Org (Execute), U: No/F: No
  - | └ Set To Default (Execute), U: No, F: No
  - | └ Item Attribution (**Non-Changeable**, Changeable), U: No/F: No
  - | └ Date&Time Setting, U: No, F: No
    - | | └ Year (**2018** to 2099), U: No, F: No
    - | | └ Month (**1** to 12), U: No, F: No
    - | | └ Date (**1** to 31), U: No, F: No
    - | | └ Hour (**0** to 23), U: No, F: No
    - | | └ Minute (**0** to 59), U: No, F: No
    - | | └ Second (**0** to 59), U: No, F: No
    - | | └ Timezone (Selecting timezone), U: No, F: No
  - | └ Processor Unit IP (1 to 254; **4**), U: No, F: No

**6 Shortcut Menu**

- └ TX Pulse Length -H1
- └ TX Power -H1
- └ TVG-Near -H1
- └ TVG-Medium -H1
- └ TVG-Far -H1
- └ AGC -H1
- └ 2nd AGC -H1
- └ Color -H1
- └ Echo Average -H1

**SPECIFICATIONS OF COLOR SCANNING SONAR  
FSV-85 MARK-2**

**1 GENERAL**

- 1.1 Scanning method Full digital beam forming
- 1.2 Frequency 80 kHz
- 1.3 Range and Pulse-length

Basic range (m)	Range (m)	
	Off-center 'OFF'	Off-center 'ON'
60	0-60	0-96
100	0-100	0-160
150	0-150	0-240
200	0-200	0-320
300	0-300	0-480
400	0-400	0-640
500	0-500	0-800
600	0-600	0-960
700	0-700	0-1120

Basic range (m)	Range (m)	
	Off-center 'OFF'	Off-center 'ON'
800	0-800	0-1280
900	0-900	0-1440
1000	0-1000	0-1600
1100	0-1100	0-1760
1200	0-1200	0-1920
1400	0-1400	0-2240
1600	0-1600	0-2560
2000	0-2000	0-3200

- 1.4 Audio search 30°, 60°, 90°, 180°, 330° selectable
- 1.5 Audio output Audio terminal

**2 MONITOR UNIT (OPTION)**

- 2.1 Pixel number
  - Horizontal SXGA (1280 x 1024), UXGA (1600 x 1200), WUXGA (1920 x 1200)
  - Vertical SXGA (1024 x 1280, 90° clockwise)
- 2.2 Color 32 colors (sonar picture), 6 colors (marks)
- 2.3 Orientation Head-up, North-up\*, Course-up\* and True-motion\*  
(\*: sensor required)
- 2.4 Presentation mode Horizontal, S-scan, Horizontal combination, S-scan combination, Vertical 1 combination, Vertical 2 combination, Echo sounder combination, Vertical 1 + echo sounder
- 2.5 Features Custom mode, Interference rejecter, Echo average, Noise limiter, Signal level, Auto-tilt, Automatic target tracking (target lock), Fish alarm, Over-voltage warning, Unretracted transducer warning

**3 TRANSCIEVER UNIT**

- 3.1 Transmitter PDM half-bridge
- 3.2 Receiving method Straight amplifier, full digital beam forming
- 3.3 H-mode beam-width TX: 360° x 10.7°, RX: 12.6° x 10.1° (-6 dB full width)
- 3.4 V-mode beam-width TX: 12.7° x 118.2°, RX: 12.6° x 12.1° (-6 dB full width)
- 3.5 S-mode beam-width TX: 206.7° x 12.1°, RX: 12.6° x 12.0° (-6 dB full width)
- 3.6 Tilt angle -5° to 90° (downward)
- 3.7 Vertical search range 0° to 90° (downward)

**4 HULL UNIT**

Travel (mm)	Dome		Raise/lower time (sec)	Ship's speed allowance (at R/L operation)
	attached	blank		
800	FSV-8471-MK2	FSV-8472-MK2	8	18 kn
1100	FSV-8481-MK2	FSV-8482-MK2	11	(15 kn)



## 5 INTERFACE

- 5.1 Number of ports
- |                 |   |
|-----------------|---|
| Serial          | 5 ports, NMEA0183 (Ver1.5/2.0/3.0/4.0/4.1)              |
| LAN             | 2 ports, Ethernet, 10/100/1000Base-T                    |
| USB             | 4 port (USB2.0: 1, USB3.0: 2)                           |
| External KP     | 2 ports (in: 1, out: 1), current loop or voltage signal |
| Gyrocompass     | 1 port, AD-10 format                                    |
| Contact closure | 4 channels, for external switch                         |
- 5.2 Data sentences
- |                 |   |
|-----------------|---|
| Input           | CUR, DBS, DBT, DPT, GGA, GLL, GNS, HDG, HDM, HDT, MDA, MTW, MWV, RMC, VBW*1, VDR, VHW, VTG, VWR, VWT, ZDA |
| Output sentence | TLL   |
- \*1: Fore-aft and port-stbd speeds required.
- 5.3 Output proprietary sentence
- |      |   |
|------|---|
| PFEC | evt, fkv, fmg, fvc, pidat, sht, tfm, tlm, tqm |
|------|---|

## 6 POWER SUPPLY

- |                                      |  |
|--------------------------------------|--|
| 6.1 Processor unit                   | 12-24 VDC: 4.0-2.0 A                                 |
| 6.2 Transceiver unit                 | 100/110/115/220/230 VAC: 15 A max., 1 phase, 50/60Hz |
| 6.3 Hull unit                        | 200-220 VAC: 4 A max., 3 phase, 50/60Hz              |
| 6.4 AC/DC power supply unit (option) |  |
| PR-241                               | 100-230 VAC, 1 phase, 50-60Hz                        |

## 7 ENVIRONMENTAL CONDITION

- 7.1 Ambient temperature
- |                         |                |
|-------------------------|----------------|
| Processor/ Control unit | -15°C to +55°C |
| Transducer              | -5°C to +35°C  |
| Others                  | 0°C to +50°C   |
- 7.2 Relative humidity 93% max. at +40°C
- 7.3 Degree of protection
- |                          |                              |
|--------------------------|------------------------------|
| Control unit             | IP22 (panel), IP20 (chassis) |
| Processor unit           | IP22                         |
| Transducer               | IPX8                         |
| Transceiver unit, others | IPX0                         |
- 7.4 Vibration IEC 60945 Ed.4

## 8 UNIT COLOR

- |                            |                                |
|----------------------------|--------------------------------|
| 8.1 Control unit           | N2.5 (Chassis), N1.0 (Key pad) |
| 8.2 Processor unit         | N2.5                           |
| 8.3 Transceiver/ Hull unit | 2.5G7/2                        |

# INDEX

---

## **Numerics**

- 2nd AGC
  - horizontal display .....2-13
  - slant display .....4-9
  - vertical display.....3-10
- 2nd AGC distance
  - horizontal display .....2-13
  - slant display .....4-10
- 2nd AGC stern
  - horizontal display .....2-13
  - slant display .....4-10
- 2nd AGC type
  - horizontal display .....2-13
  - slant display .....4-10

## **A**

- Absorption coefficient.....2-11
- AGC
  - horizontal display .....2-12
  - slant display .....4-8
  - vertical display.....3-9
- ALARM & AUDIO menu .....7-4
- Aural detection of school of fish
  - audio sector, slant display .....4-19
  - automatic training, horizontal display .....2-26
  - bearing setting.....2-25
  - reverberation for audio signal, slant display..4-20
  - reverberation setting .....2-27
  - sector setting.....2-26
- AUTO TILT key .....4-5
- Auto train
  - slant display .....4-6
- AUTO TRAIN key.....2-26, 3-5

## **B**

- Beam width
  - horizontal display .....2-20
  - slant display .....4-15
  - vertical display.....3-15
- Bearing measurement
  - slant display .....4-6
- Bearing reference .....7-4
- Bearing scale .....7-10
- Board test.....9-14

## **C**

- Color
  - color arrangement, horizontal display ....2-37
  - color arrangement, vertical display .....3-17
  - color response, horizontal display .....2-38
  - color setting, horizontal display .....2-37
  - color setting, vertical display .....3-17
- Concentration of school of fish.....2-29
  - slant display .....4-23
- CURRENT & VEC WIND menu .....7-13

## **D**

- Data display
  - description.....5-2
  - full.....5-1
- DATA DISPLAY menu .....7-9
- Data on track.....7-10
- DELETE MARK key ....2-32, 2-34, 4-26, 4-28
- DISPLAY SETTING menu .....7-3

## **E**

- Echo average
  - horizontal display .....2-18
  - slant display .....4-15
  - vertical display.....3-14
- ERASE MARKS menu .....7-1
- Erase Marks menu .....2-32, 4-26
- Error codes .....9-12
- ESTIMATE keys.....2-29, 4-23
- EVENT key .....2-33
- Event mark
  - deleting.....2-34
  - deleting, slant display.....4-28
  - entering .....2-33
  - entering, slant display .....4-27

## **F**

- Fish alarm
  - alarm level.....7-5
  - slant display .....2-27, 4-20
- FISH key .....2-31, 4-25
- Fish marks
  - connecting.....7-10
  - deleting.....2-32
  - deleting, slant display.....4-26
  - entering .....2-31
  - measuring speed with .....2-31, 4-25
- Frequency shift
  - horizontal display .....2-17
  - slant display .....4-13
  - vertical display.....3-12
- Frequency shift (bearing)
  - horizontal display .....2-19
- Function keys
  - erasing programs .....6-4
  - executing.....6-3
  - programming .....6-3

## **G**

- GAIN control .....1-15
- Gain offset
  - horizontal display .....2-37
  - slant display .....4-30
  - vertical display.....3-16

## **H**

- Heading mark.....7-9

Horizontal mode  
  horizontal2 mode..... 2-3  
Hull unit maintenance..... 9-2

**I**

INITIAL SETTING menu ..... 7-7  
INITIALIZATION menu ..... 7-16  
Interference rejector  
  horizontal display ..... 2-17  
  slant display ..... 4-13  
  vertical display..... 3-12

**K**

Key beep volume ..... 7-4

**M**

Maintenance  
  hull unit..... 9-2  
MARK DISPLAY menu..... 7-9  
MARK SIZE menu ..... 7-11  
Memory card  
  deleting files from ..... 8-2  
  formatting ..... 8-4  
  loading files from ..... 8-2  
  saving picture to ..... 8-1  
Menu operation ..... 1-16  
Mode selection method ..... 7-3

**N**

Near AGC  
  horizontal display ..... 2-12  
  slant display ..... 4-9  
  vertical display..... 3-9  
Net course mark..... 2-35  
  slant display ..... 4-28  
Net movement plot..... 7-10  
NET SHOOT SETTING menu..... 7-15  
NET SONDE SETTING menu..... 7-14  
Noise limiter  
  horizontal display ..... 2-18  
  slant display ..... 4-14  
  vertical display..... 3-13

**O**

Off center ..... 2-28  
OFF CENTER key..... 2-28, 4-21  
OTHERS menu ..... 7-1  
  horizontal display ..... 2-37  
  slant display ..... 4-30  
  vertical display..... 3-16  
Own ship position mark..... 2-34

**P**

Panel test ..... 9-15  
Post 2nd AGC  
  horizontal display ..... 2-13  
  slant display ..... 4-10  
Power switches ..... 1-5  
Presentation mode ..... 2-24  
PRESET, MEMORY CARD menu ..... 7-6

**R**

R/B AUDIO key ..... 2-25, 4-19  
Range  
  slant display ..... 2-4, 4-4  
  vertical display..... 3-6  
Range and bearing measurement  
  horizontal display..... 2-9  
Range and bearing measurement  
  vertical display..... 3-6  
RANGE control..... 3-6, 4-4  
Range measurement  
  slant display ..... 4-6  
Range rings..... 7-9  
Reverberation  
  horizontal display..... 2-18  
  slant display ..... 4-14  
  vertical display..... 3-14

**S**

Ship?s track ..... 7-10  
SHOOT key..... 2-36, 4-29  
Sidelobe suppression  
  horizontal display..... 2-19  
  slant display ..... 4-15  
  vertical display..... 3-14  
Signal level  
  horizontal display..... 2-37  
  slant display ..... 4-30  
  vertical display..... 3-16  
Slant display  
  combination display..... 4-3  
  full-screen display..... 4-2  
Smoothing  
  horizontal display..... 2-39  
  slant display ..... 4-31  
  vertical display..... 3-17  
STABILIZATION menu..... 7-15  
Status messages..... 9-12

**T**

Target  
  fish mode, slant display ..... 4-17  
  mode selection, slant display ..... 4-16  
Target lock  
  dimensions, horizontal display ..... 2-23  
  dimensions, slant display ..... 4-18  
  fish mode, horizontal display ..... 2-22  
  fish track plot ..... 7-10  
  mark interlock, horizontal display ..... 2-23  
  mark interlock, slant display ..... 4-18  
  mode selection, horizontal display ..... 2-21  
  smoothing, horizontal display ..... 2-23  
  smoothing, slant display ..... 4-18  
  target lock window, horizontal display ... 2-23  
  target lock window, slant display ..... 4-18  
  target mark mode, horizontal display .... 2-22  
  target mark mode, slant display ..... 4-18  
  target speed limit, horizontal display .... 2-23  
  target speed limit, slant display ..... 4-18  
  target speed update, horizontal display. 2-23

## INDEX

target speed update, slant display .....	4-18
threshold, horizontal display.....	2-23
threshold, slant display.....	4-18
tilt interlock, horizontal display .....	2-23
tilt interlock, slant display .....	4-18
tracking data, horizontal display.....	2-23
tracking data, slant display.....	4-18
volume setup, slant display .....	4-18
volumes setup, horizontal display .....	2-23
TARGET LOCK key .....	2-22, 4-17
TARGET LOCK menu.....	2-23
TEST menu.....	9-12
Test pattern.....	9-16
Tilt angle	
automatic.....	2-5
automatic, slant display.....	4-5
setting.....	2-5
setting, slant display.....	4-4
TILT control function .....	7-4
Tilt mark .....	3-4
Trackball maintenance .....	9-7
Trackball mark position reference mark .....	3-5
Transducer	
automatic raising from hull unit .....	9-16
manual raising from hull unit .....	9-18
True motion display range .....	7-4
TVG curve	
slant display .....	2-9, 4-7
vertical display.....	3-7
TVG distance	
horizontal display .....	2-10
slant display .....	4-8
vertical display.....	3-8
TX interval.....	2-16
slant display .....	4-12
TX power	
horizontal display .....	2-15
slant display .....	4-11
TX pulse length	
horizontal display .....	2-14
slant display .....	4-10
vertical display.....	3-11
TX/RX mode .....	7-3
<b>U</b>	
User menu	
deleting items from.....	6-1
programming.....	6-1
USER PROG control	
display range programming.....	6-7
program selection.....	6-6
programming.....	6-6
<b>V</b>	
Vertical bearing mark .....	3-4
<b>W</b>	
Warning messages .....	9-10



## Declaration of Conformity



We **FURUNO ELECTRIC CO., LTD.**

(Manufacturer)

9-52 Ashihara-Cho, Nishinomiya City, 662-8580, Hyogo, Japan

(Address)

declare under our sole responsibility that the product

**COLOR SCANNING SONAR FSV-85-MARK-2 and FSV-85L-MARK-2**

(Model name, type number)

to which this declaration relates conforms to the following standard(s) or other normative document(s)

### EU

EMC Directive 2014/30/EU

IEC 60945 Ed.4.0: 2002, clauses 9.2, 9.3, 10.3, 10.4, 10.5, 10.6, 10.7, 10.8 and 10.9, incl. Corr. 1: 2008

For assessment, see

• Test report  
Labotech International Co., Ltd.  
LIC 12-21-011, 19 Feb 2021

### UK

SI 2016 No.1091 EMC Regulations 2016 as amended

EN 60945: 2002, clauses 9.2, 9.3, 10.3, 10.4, 10.5, 10.6, 10.7, 10.8 and 10.9, incl. IEC 60945 Corr. 1: 2008

For assessment, see

• Test report  
Labotech International Co., Ltd.  
LIC 12-21-011, 19 Feb 2021

(title and/or number and date of issue of the standard(s) or other normative document(s))

On behalf of Furuno Electric Co., Ltd.

Nishinomiya City, Japan  
27 May 2021

(Place and date of issue)

Akihiko Kanechika  
Department General Manager  
Quality Assurance Department

(name and signature or equivalent marking of authorized person)