



**Bluetooth® Enabled
Smart™ Sensors**

Available Spring 2020

DST810 Smart™ Multisensor

For a product to be considered “breakthrough,” it has to vastly change conventional behavior and enhance abilities. The new DST810 Smart Multisensor, together with Airmar’s CAST™ App, is the convergence of advanced hull data, matched with a simple and reliable way to calibrate accurate speed via a wireless device. This changes how boaters receive and deliver information to get greater performance from their hull. It is a simple, consistent way to calibrate speed-through-water regardless of what display system is on board. The DST810 and Airmar CAST App deliver capabilities that until now, were only available through expensive PC based software.

Besides water temperature, depth and newly upgraded 5 Hz (5X per second) speed-through-water output, the DST810 features an integrated attitude sensor for heel and trim data. This information, combined with Airmar’s powerful and simple CAST App, makes heel-compensated speed calibration across multiple heel angles and speed ranges both fast and intuitive, and is independent of the onboard instruments.

All speed calibrations and NMEA configurations are stored in the DST810 sensor—not in the displays.



- **NEW**—5 Hz speed output (5X per second) for visibly smoother speed-through-water reporting and faster data for better decision making
- **NEW**—Integrated attitude sensor for heel and trim benefits sailing and power boats
 - Simple attitude calibration to correct for off-center mounting
- **NEW**—Wireless connectivity to Airmar’s CAST App has new user-friendly benefits:
 - Calibrate the DST810 in a simple, intuitive way regardless of the instrument brand or model that is on board
 - Conduct basic and advanced heel-compensated speed calibrations for improved speed-through-water outputs across the speed range
 - Advanced Speed Calibration allows for manual speed entries for multiple heel angles and up to 10 speeds, formerly only possible through expensive PC software
 - Enable and disable PGN’s and set offset and output rates



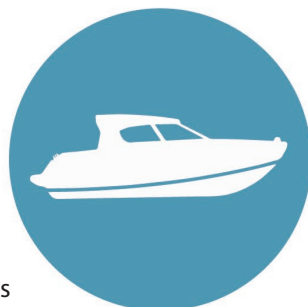

SAILING

- New 5 Hz speed output for visibly smoother speed data.
- Incredibly easy calibration via Airmar's CAST App. Wirelessly connect, calibrate speed, and configure data.
- DST810 stores configurations and delivers data to the NMEA2000® network.
- Depth, heel-corrected speed-through-water, heel and trim, and water temperature from one installed multisensor.

POWERBOATS

- 5 Hz speed, depth, pitch and roll, and water temperature from one installed instrument.
- Simple depth offsets and corrected speed-through-water via Airmar's CAST App.
- Popular depth sensor for reliable shallow water performance.

Easily retrofits to most Airmar 2" housings

SPECIFICATIONS

Weight:

- 0.9 kg (2.0 lb)—Plastic
- 1.6 kg (3.5 lb)—Bronze
- 1.9 kg (4.2 lb)—Stainless Steel

Acoustic Window: Urethane

Hull Deadrise: Up to 22°

Data Update Rate: Depth: 1X/second
Speed: 5X/second
Heel/Trim: 10X/second

Attitude Accuracy: +/- 1° nominal after sensor calibration

Depth Frequency: 235 kHz

Minimum Depth Range: 0.5 m (1.6')

Maximum Depth Range: Up to 100 m (330')—NMEA2000®

Speed Range: Up to 45 knots

Pressure Rating: 3 m (10')

Pulse Rate: 20,000 p/nm* (5.6 Hz per knot)

Supply Voltage: 9 VDC to 16 VDC— per NMEA2000®

Supply Current: <200 mA— per NMEA2000®

Wireless Protocol: Bluetooth Low Energy (BLE)

Wireless Range: Up to 30 feet depending on mount location

Standard Cable Length: 6 m (20') DeviceNet—NMEA2000®

Temperature Sensor Accuracy: ±0.5°C (±1.8°F)

Temperature Sensor Range: -10°C to 40°C (14°F to 104°F)

NMEA2000® Load Equivalency Number (LEN): 3

CE Regulation: Complies to IERC60945

*p/nm = pulses per nautical mile



Use the Airmar CAST™ App to calibrate speed at multiple heel angles and numerous speeds for optimal performance.

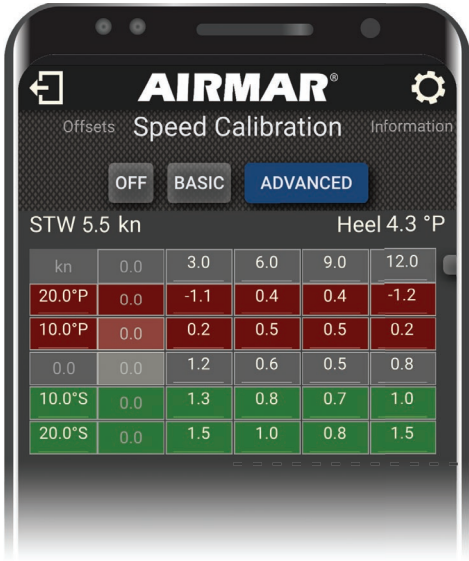

Wirelessly connects

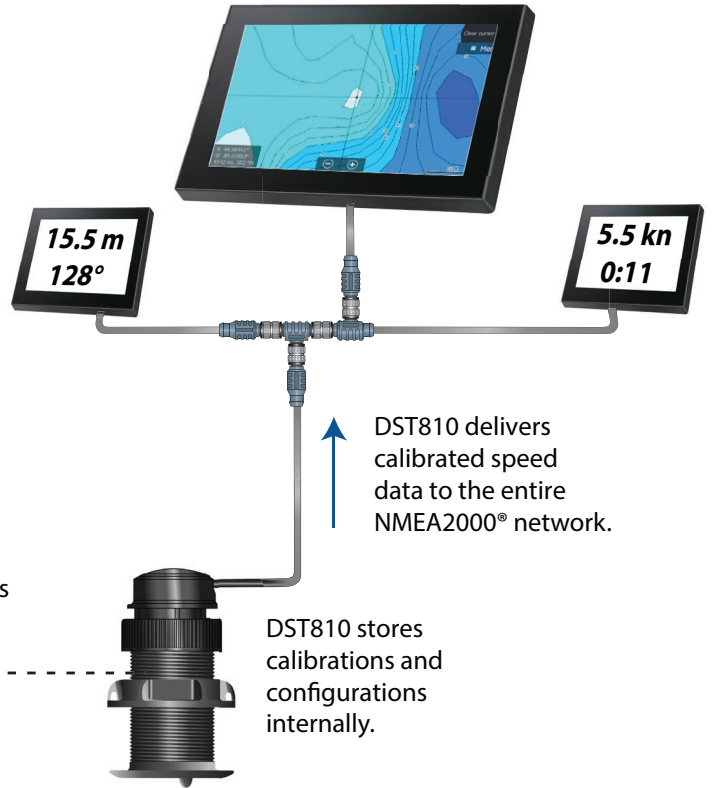

Configure outputs

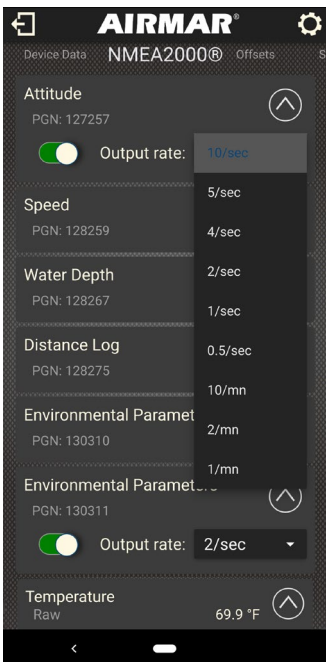

Display data / gauges

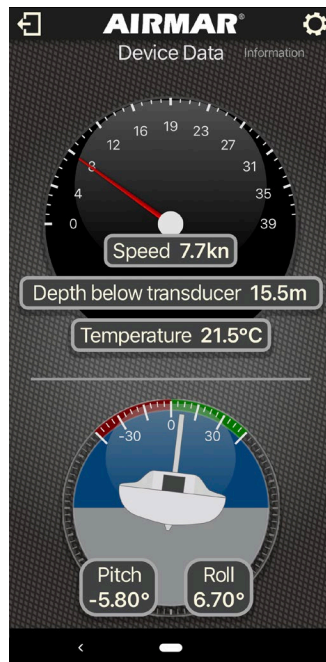

Calibrate basic or heel compensated speeds

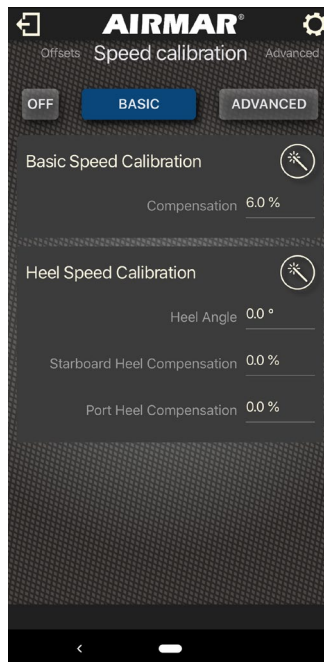

Configure offsets and calibrate attitude

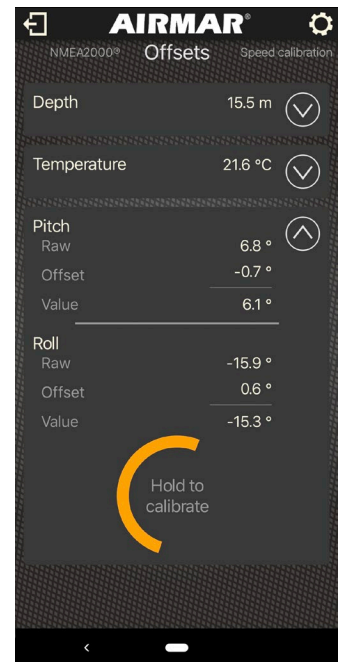

DATA OUTPUT PROTOCOL

NMEA2000® Supported PGNs

59392ISO Acknowledgement
600928ISO Address Claim
126208Acknowledge Group Function
126464Transmit PGN List Group Function
126464Received PGN List Group Function
126996Product Information
128259Speed (Speed Water Reference)
128267Water Depth (With Transducer Offset)
128275Distance Log
130310Environmental Parameters (Water Temperature)
130311Environmental Parameters (Water Temperature)
130312Environmental Parameters (Water Temperature)
127257Attitude

DIMENSIONS

P617V Plastic, B617V Bronze, and SS617V Stainless Steel

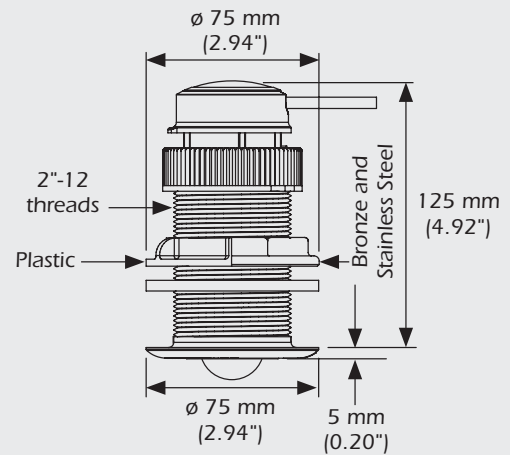

Airmar's innovative housing design incorporates a self-closing valve to minimize water flow into boat when the insert is removed.



www.airmar.com

©2020 AIRMAR Technology Corporation

DST810_rD 04/15/20

As AIRMAR constantly improves its products, all specifications are subject to change without notice. All AIRMAR products are designed to provide high levels of accuracy and reliability, however they should only be used as aids to navigation and not as a replacement for traditional navigation aids and techniques. Smart™ is a trademark of AIRMAR Technology Corporation. The Bluetooth® word mark and logos are registered trademarks owned by Bluetooth SIG, Inc. and any use of such marks by AIRMAR Technology Corporation is under license. Other company or product names mentioned in this document may be trademarks or registered trademarks of their respective companies, which are not affiliated with AIRMAR.

