

Installation Manual **COLOR SCANNING SONAR**

Model FSV-25/FSV-25S

SAFETY INSTRUCTIONS	i	APPENDIX 1 JIS CABLE GUIDE	AP-1
SYSTEM CONFIGURATION	iii	APPENDIX 2 FRP TANK	
EQUIPMENT LISTS.....	iv	INSTALLATION.....	AP-2
1. HOW TO INSTALL THE SYSTEM ..	1-1	PACKING LISTS	A-1
1.1 Hull Unit (FSV-253/FSV-254).....	1-1	OUTLINE DRAWINGS	D-1
1.2 Processor Unit (FSV-2503/FSV-2503S)....	1-7	INTERCONNECTION DIAGRAMS	S-1
1.3 Control Unit (FSV-2501)	1-9		
1.4 Transceiver Unit (FSV-251)	1-12		
1.5 Power Supply Unit (FSV-252).....	1-14		
1.6 IF (Interface) Unit (FSV-8502)	1-15		
1.7 Junction Box (FSV-2550).....	1-15		
1.8 Raise/Lower Control Box (FSV-2530)..	1-15		
1.9 Control Box Extension Box (FSV-2560)..	1-16		
1.10 Attachment Flange (Option).....	1-17		
1.11 Remote Controller (FSV-2504)	1-18		
2. WIRING.....	2-1		
2.1 How to Connect the Units	2-1		
2.2 Processor Unit	2-3		
2.3 IF Unit	2-7		
2.4 Control Unit and Remote Controller....	2-9		
2.5 Transceiver Unit.....	2-11		
2.6 Junction Box	2-13		
2.7 Raise/Lower Control Box	2-14		
2.8 Power Supply Unit	2-15		
2.9 Control Box Extension Box	2-17		
3. POST INSTALLATION SETTINGS	3-1		
3.1 How to Set the Language	3-1		
3.2 How to Set Up the Transducer.....	3-3		
3.3 Hull Unit Checks	3-4		
3.4 How to Access the System Menu	3-8		
3.5 How to Adjust the Heading	3-9		
3.6 How to Configure the Own Ship Mark..	3-10		
3.7 How to Set Up a Secondary Monitor.	3-10		
3.8 Other System Menu Items	3-11		



FURUNO ELECTRIC CO., LTD.

www.furuno.com

All brand and product names are trademarks, registered trademarks or service marks of their respective holders.

ECF

(Elemental Chlorine Free)

The paper used in this manual
is elemental chlorine free.

FURUNO ELECTRIC CO., LTD.

9-52 Ashihara-cho,
Nishinomiya, 662-8580, JAPAN

• FURUNO Authorized Distributor/Dealer

All rights reserved. Printed in Japan

Pub. No. IME-13440-H1

(ETMI) FSV-25/25S

A : MAY 2014

H1 : MAY 14, 2021





0 0 0 1 7 8 7 7 3 1 7



SAFETY INSTRUCTIONS

The installer must read the safety instructions before attempting to install the equipment.

 DANGER	Indicates a potentially hazardous situation which, if not avoided, will result in death or serious injury.
 WARNING	Indicates a potentially hazardous situation which, if not avoided, could result in death or serious injury.
 CAUTION	Indicates a potentially hazardous situation which, if not avoided, may result in minor or moderate injury.

 Warning, Caution	 Prohibitive Action	 Mandatory Action
--	--	--

 **DANGER**



Keep away from raise/lower shaft in hull unit when it is moving.

Gears will cause serious injury.

 **WARNING**



Do not open the equipment unless totally familiar with electrical circuits and service manual.

High voltage exists inside the equipment, and a residual charge remains in capacitors several minutes after the power is turned off. Improper handling can result in electrical shock.

 **Do not remove the hull unit brake.**

There is a risk of the shaft falling out.

 **Turn off power at the switchboard before starting the installation.**

Electrical shock or fire can result if the the power is left on.

 **Make sure the drive shaft brake and motor brake are functioning normally before moving the transducer manually.**

 **WARNING**

 **Do not install the equipment where it may get wet from rain or water splash.**

Water can cause fire or electrical shock, or damage the equipment.

 **Be sure no water leaks in at the hull unit.**

Water leakage can sink the vessel. Also confirm that the transducer will not loosen by ship's vibration. The installer of the equipment is solely responsible for the proper installation of the equipment. FURUNO will assume no responsibility for any damage associated with improper installation.

 **Install the specified transducer tank in accordance with the installation instructions. If a different tank is to be installed the shipyard is solely responsible for its installation, and it should be installed so the hull will not be damaged if an object strikes the tank.**

The tank or hull may be damaged if the tank strikes an object.

⚠ WARNING

! If a steel tank is installed on a wooden or FRP vessel, take appropriate measures to prevent electrolytic corrosion.

Electrolytic corrosion can damage the hull.

! **Be sure to power each unit with proper voltage.**

Connection of an improper power supply can cause fire or damage the equipment.

! **When checking the break on the hull unit, always take measures against static electricity.**

Static electricity can cause the unit to move unexpectedly, which can result in personal injury to damage to unit.

⚠ CAUTION

! Maximum speed while the transducer is projected or being raised or lowered is as below, to prevent damage to the transducer.

Projected length (mm)	Projected	Raising/ Lowering
1100 or less	Max. 20 kn	Max. 14.5 kn
1100 to 1300	Max. 18 kn	Max. 13.5 kn
Over 1300	Max. 16 kn	Max. 12 kn

! **Ground the equipment to prevent electrical shock and mutual interference.**

! **Observe the following compass safe distances to prevent interference to a magnetic compass:**

	Standard compass	Steering compass
Processor Unit	1.45 m	0.90 m
Control Unit FSV-2501	0.35 m	0.30 m
IF Unit	0.80 m	0.50 m
Sub Control Unit FSV-853	0.90 m	0.55 m

! **Confirm there are no foreign objects on the connecting cable terminals.**

Foreign objects may cause the hull unit to move unintentionally.

SYSTEM CONFIGURATION

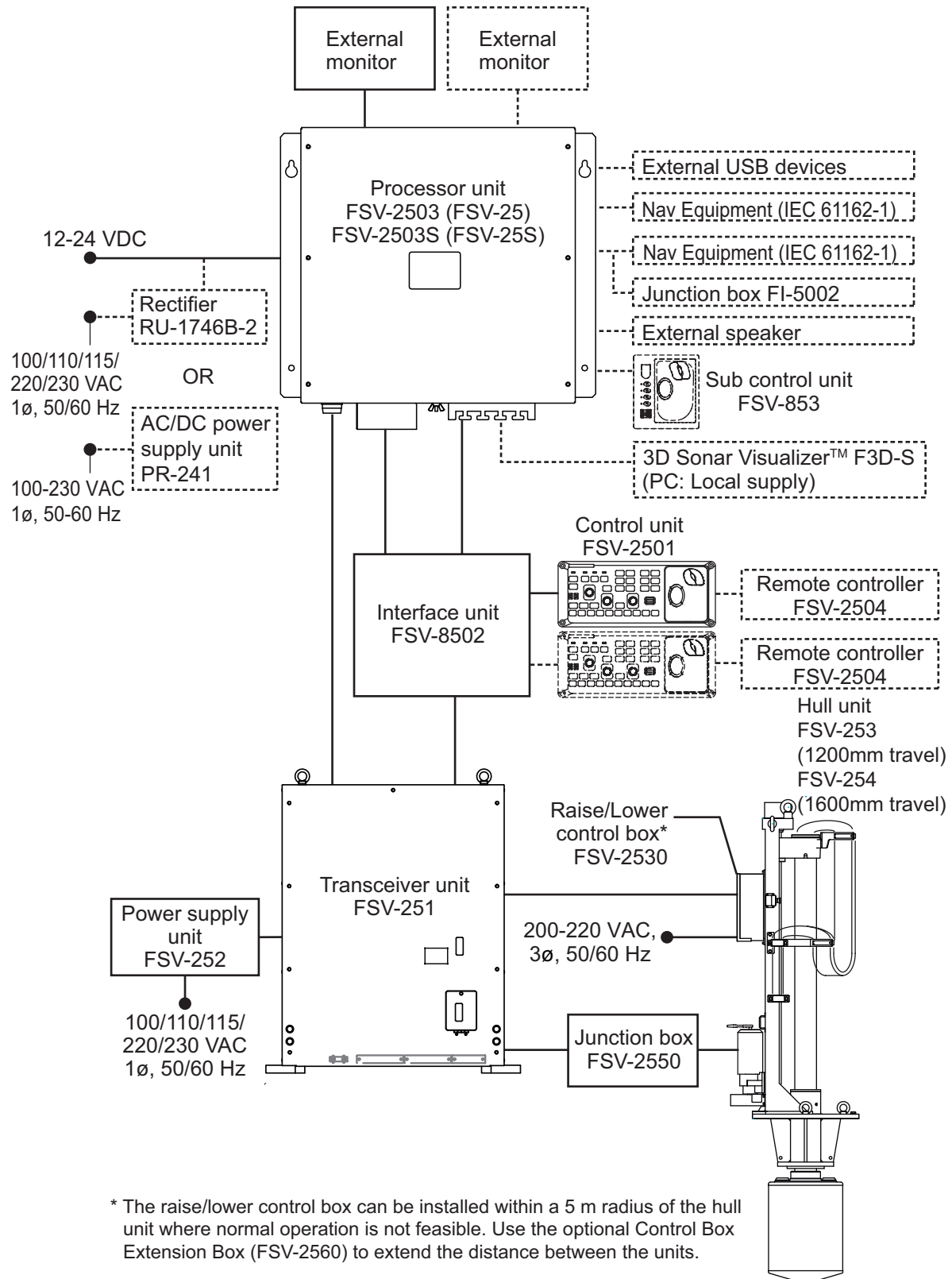

EQUIPMENT LISTS

Standard supply

Name	Type	Code No.	Qty	Remarks
Control unit	FSV-2501	-	1	Includes cable for control unit (5 m/10 m)
Interface unit	FSV-8502	-	1	
Processor unit	FSV-2503	-	1	For FSV-25
Processor unit	FSV-2503S	-	1	For FSV-25S
Transceiver unit	FSV-251	-	1	
Power supply unit	FSV-252	-	1	
Junction box	FSV-2550	-	1	Includes cable (5m/10 m/20 m)
Hull unit	FSV-253	-	1	For 1200 travel
	FSV-254	-		For 1600 travel
Installation materials	CP10-07200	000-017-257	1	For Control unit, includes CP10-07201 and CP03-33202
	CP10-07300	000-017-123	1	For Interface unit, includes CP10-07301 and cables
	CP19-00600	000-011-664	1	For Processor unit, includes CP19-00601
	CP10-09300	000-027-169	1	For Transceiver unit
	CP10-07701	001-267-450	1	For Power supply unit
	CP10-09400	001-406-770	1	Cabling for Junction box (5 m)
	CP10-07800	001-267-540		Cabling for Junction box (10 m)
	CP10-07900	001-267-550		Cabling for Junction box (20 m)
	CP10-08220	000-029-313	1	Cabling for Hull unit (5 m)
	CP10-08200	000-025-104		Cabling for Hull unit (10 m)
	CP10-08210	000-029-312		Cabling for Hull unit (20 m)
	CP10-08300	000-025-069	1	For Hull unit, includes CP10-08101, CP10-08301
Spare parts	SP19-00501	001-023-090	1	For Processor unit
	SP10-03901	001-268-990	1	For Transceiver unit
	SP10-04201	001-269-280	1	For Hull unit

Optional supply

Name	Type	Code No.	Remarks
Control unit	FSV-2501	-	Includes cable for control unit (5 m/10 m)
Sub control unit	FSV-853	000-019-212	
Rectifier unit	RU-1746B-2	000-030-439	
AC/DC power supply unit	PR-241	-	
Remote controller	FSV-2504	-	Includes installation materials: CP10-07401
Retraction tank	OP10-40	001-269-630	For steel-hull vessels
Attachment kit	OP10-24	006-943-530	
Attachment flange	OP10-42	001-269-580	150 mm
	OP10-38	001-269-590	200 mm
	OP10-39	001-269-600	250 mm
	OP10-43	001-269-610	280 mm
	OP10-44	001-269-620	315 mm
Fixing materials	OP10-9	006-990-040	For remote controller
Ferrite core	OP86-11	001-594-450	For PR-241
Flush mount kit	FP03-09870	008-535-630	
Junction box	FI-5002	000-010-765	For processing NMEA signals to navigational equipment
Control box extension box	FSV-2560	000-025-105	For remote installation of control box
E/S cable	VV-S0.3X8C *6M*	001-257-220	6 m
Cable assembly	MJ-A7SPF0007-050C	000-154-028	NMEA cable
	10CA10053	001-408-440	For transceiver (5 m)
		001-269-570	For transceiver (20 m)
Cabling	10S2380	001-169-330	10 m
		001-169-340	20 m
		001-169-350	30 m
		001-169-360	40 m
		001-169-370	50 m
		001-169-380	60 m
		001-169-390	100 m
Installation materials	CP03-28900	000-082-658	LAN cable (10 m)
	CP03-28910	000-082-659	LAN cable (20 m)
	CP03-28920	000-082-660	LAN cable (30 m)
	CP03-28930	000-084-368	LAN cable (50 m)
	CP03-28940	000-090-429	LAN cable (100 m)
3D Sonar Visualizer	F3D-S	001-546-350	Software

This page is intentionally left blank.

1. HOW TO INSTALL THE SYSTEM

1.1 Hull Unit (FSV-253/FSV-254)

Note 1: The raise/lower control box on the hull unit contains an inertial measurement unit. Handle the hull unit carefully.

Note 2: Handle the transducer carefully. Rough handling can damage its sensitive components.

1.1.1 Installation considerations

Decide the location of the hull unit through consultation with the dockyard and ship owner. When deciding the location, the following points should be taken into account.

- Select an area where propeller noise, cruising noise, air bubbles and interference from turbulence are at a minimum. Generally, the point at 1/3 to 1/2 of the ship's length from the bow on the keel is optimum. On-the-keel installation is advantageous for minimizing oil consumption. For large ships with deep draft, the hull unit can be installed at the bow, along the keel line. (See figure below for reference).

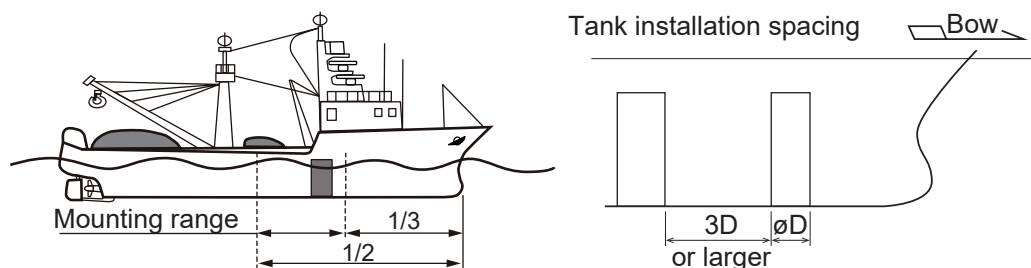

- For installations where there are other transducer tanks along the keel, install the hull unit a minimum distance of three times the internal diameter of the tank directly in front (bow direction) of the hull unit. Failure to install the hull unit with sufficient spacing can result in excessive vibrations caused by turbulence, which can damage the hull unit. (See figure above for reference).
- Select a place where the hull bottom is flat and the draft is sufficiently deep. Normally, the transducer should protrude at least 500 mm beyond the keel to minimize the effect of air foam and bubbles.
- Select a place where interference from other transducers is minimal. The hull unit should be at least 2.5 m away from the transducers of other equipment.
- No obstacle should be in the fore direction since it causes a shadow zone and aerated water, resulting in poor sonar performance.
- The physical distance between the hull unit and the transceiver unit should be no more than 5 m.
- In the case of a bilge keel, select a location as far from the bilge as possible, but no more than 5 m from the transceiver unit.
- Select a location away from indents and protrusions on the hull, especially indents, as they can create noise interference and cause poor sonar performance.
- The space shown in the figure on the next page is required around the hull unit for wiring and maintenance.
- If the ambient temperature around the unit will be below 0°C, provide the sonar compartment with a heater to keep the temperature above 0°C.

1. HOW TO INSTALL THE SYSTEM

Note 1: After you install the hull unit, make sure you install anti-vibration stays. (See "How to install the stays (anti-vibration and anti-shock measures)" on page 1-6.)

Note 2: Prepare a secure and firm safety fence for the hull unit, to prevent accidental injury from the moving hull unit. The safety fence should be easily removable for maintenance and allow room for the connected cables to swing freely with pitch, roll and heave. The raise/lower control unit and emergency button should be installed and operable from outside the safety fence.

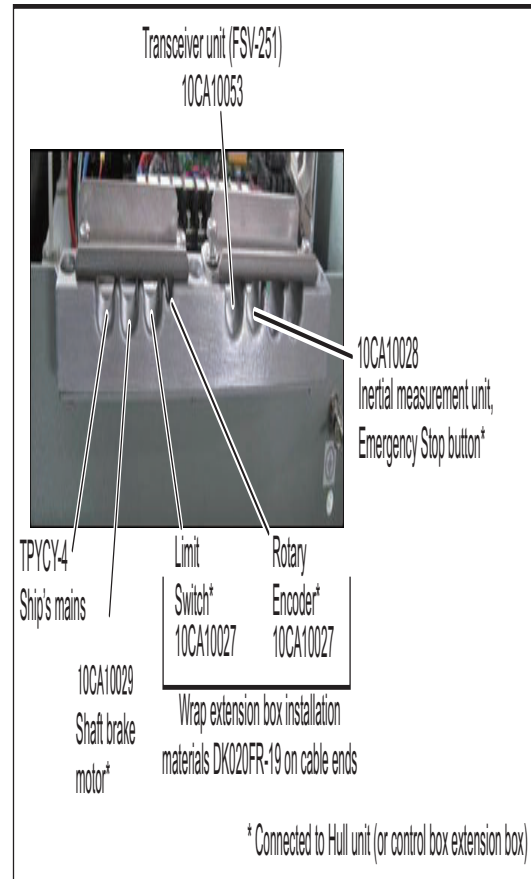

1.1.2 How to shorten the retraction tank

The following table provides cutting guidelines for shortening the tank. Refer also to the retraction tank installation drawing at the back of this manual.

Stroke	Cutting guidelines
1200 mm	100 to 110 mm
1600 mm	0 to 110 mm

Note 1: The default length for the retraction tank is 1300 mm. By removing only 88 mm from the retraction tank, you can eliminate the need for limit switch adjustment.

Note 2: For both 1200 mm and 1600 mm travel hull units, the transducer will not fully retract unless the tank is shortened by more than 90 mm.

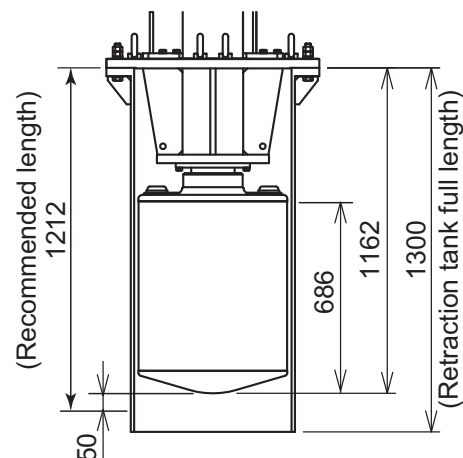

Guidelines for installation of the retraction tank

- If the keel plate on the inside of the hull is not adequate for installing the retraction tank, install a secondary keel plate.
- Install the retraction tank where the keel plate and hull frame intersect.
- If there is no suitable location where the hull frame and keel intersect, install suitable “T” shaped reinforcement ribs, then weld the base of the frame to the reinforcement ribs and the sides of the reinforcement ribs to the hull walls or other nearby reinforcement ribs. The reinforcement ribs should be secured in the fore, aft, port and starboard directions.
- Install the reinforcement ribs as near as possible to the top of the retraction tank, allowing 150 to 200 mm space for tightening of nuts and bolts.
- Fit a doubling plate (a plate added to another to give extra strength or stiffness) to the location where the retraction tank is welded to the hull bottom. While it is recommended that both sides attach to the hull, consult with the installer regarding length and diameter.
- The thickness for doubling plates and reinforcement ribs is 12 mm minimum.

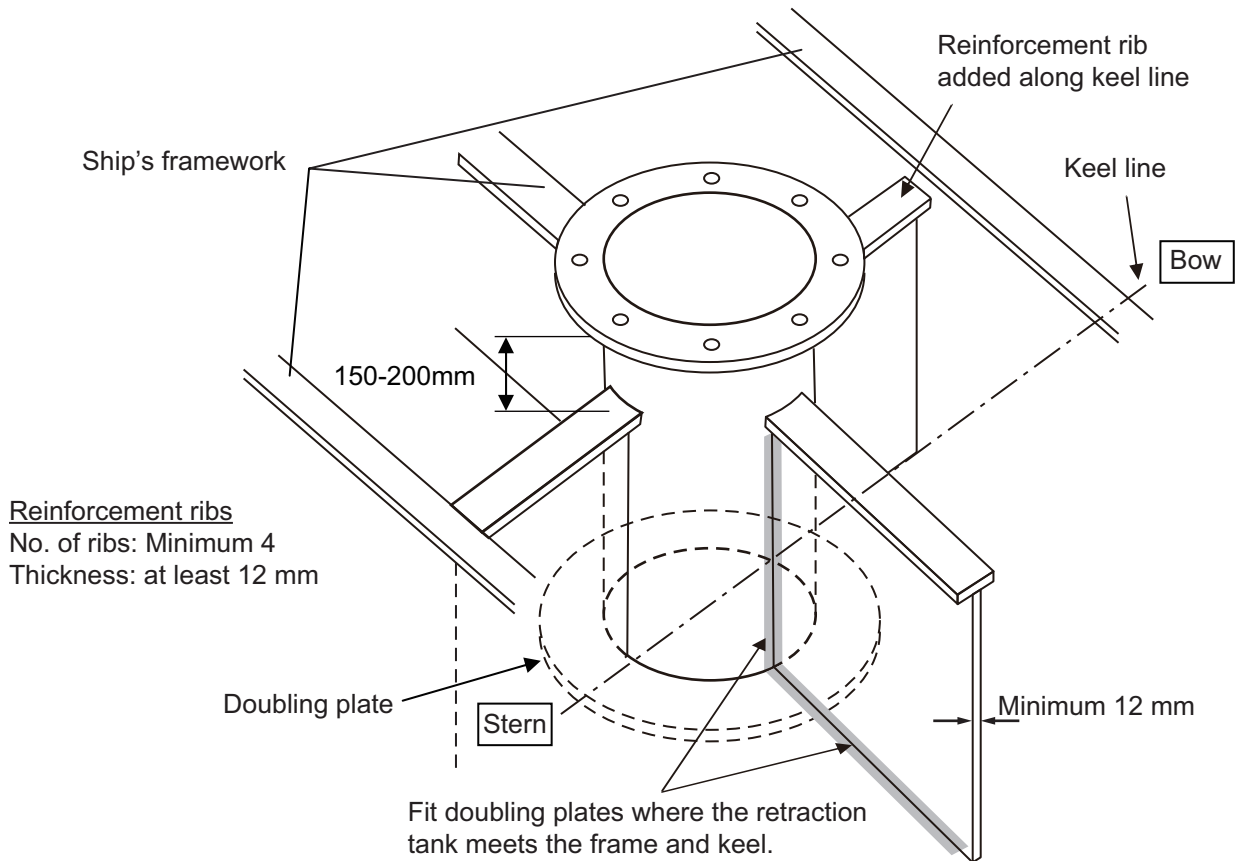

1. HOW TO INSTALL THE SYSTEM

1.1.3 How to install the hull unit on the retraction tank

Weld the retraction tank and allow sufficient time for cooling. Install the hull unit as follows:

Prepare the materials and tools as shown below.

Name	Remarks
Screw wrench	M20 (opposite side 30 mm)
Ethyl alcohol	99.5%
Waste cloths	
Lithium grease	For O-ring and drive shaft, common lithium grease (the equivalent to Daphne Grease MP #2 (IDEMIT-SU KOSAN CO.,LTD))
Molytone grease	For gears and bearings, Molytone grease #2 (by SUMICO LUBRICANT CO., LTD)

Use the figure on the following page for reference when installing the hull unit on the retraction tank.

1. Clean the flange and O-ring groove of the retraction tank (welded to hull) with ethyl alcohol moistened waste cloths.
2. Apply lithium grease to the O-ring and O-ring groove. Place the O-ring in its groove on the tank flange.
3. Orient the hull unit so that the bow mark (inscribed) on its flange points toward the ship's bow. Note that heading adjustment is required if the bow mark is not facing the ship's bow. (See "How to Adjust the Heading" on page 3-9.)
4. Confirm the points as listed below, then place the hull unit on the tank.
 - Clean the flange platform.
 - Wipe the under-face of the hull unit with clean waste cloths.
 - Keep the O-ring in its groove.
5. Apply a slight amount of lithium grease to the threads of the bolts to prevent scorching. Insert the bolts with washers from the retraction tank flange, and then put the flat washers and spring washers in this order from above. Fasten bolts with nuts.

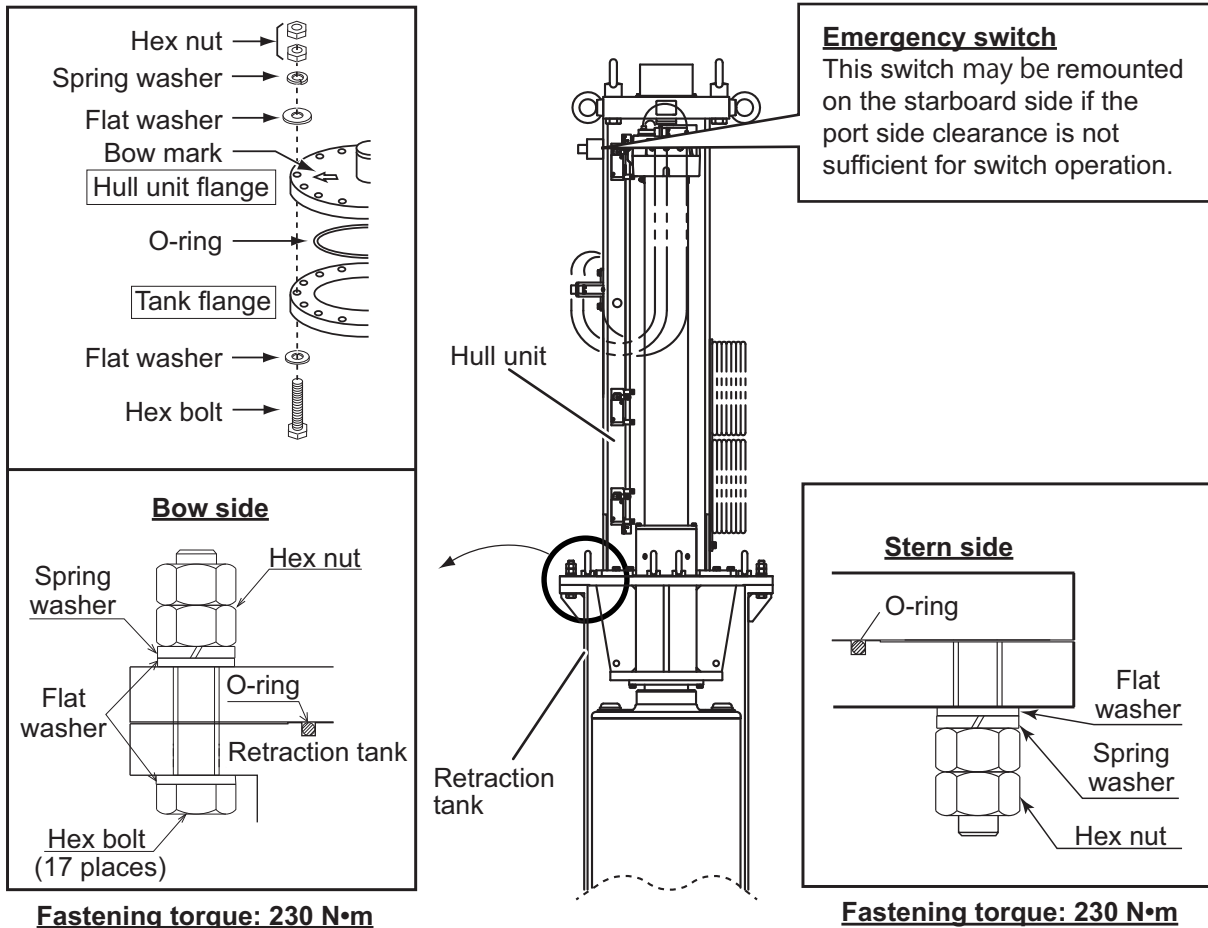

Emergency switch

The emergency switch is attached to the port side of the hull unit. If the port side clearance is not sufficient for switch operation, the switch may be remounted on the starboard side.

Note: The junction box FSV-2550 cannot be mounted to the hull unit when the emergency switch is remounted on the starboard side. Mount the junction box to a bulkhead near the hull unit.

1. HOW TO INSTALL THE SYSTEM

How to install the stays (anti-vibration and anti-shock measures)

This measure must be done after installing the hull unit to prevent damage from vibration or impact shock to the transducer. Stays should be as sturdy as possible (75×75×9 mm minimum recommended). Install a minimum of two stays, one in the aft direction, one in the fore direction. Where possible install two more stays (one in the port and one in the starboard direction), making a total of four stays. Where the hull unit is installed off center from the bow-stern line, install the stays at right angles with the bow mark on the hull unit.

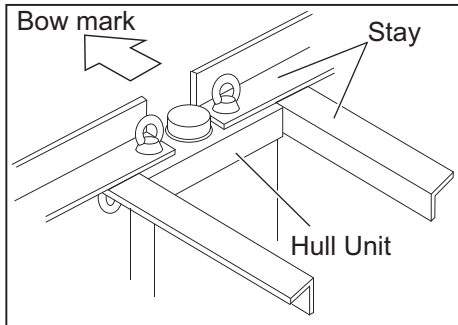

Recommended stay installation

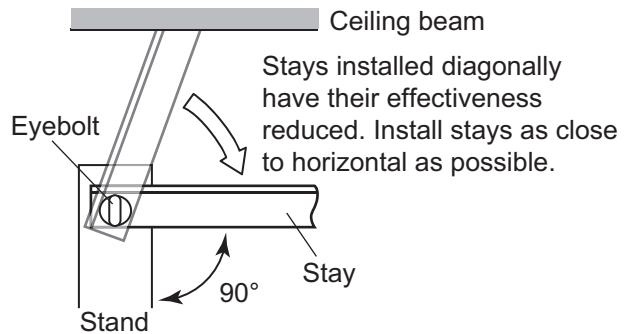

Where horizontal installation of the stays is not possible, install the stays in a diagonal manner to reduce vibration in the hull unit. Install the upper stays (attached to the top of the hull unit) in opposing directions (one facing fore, one facing aft), then attach the stays to ceiling beams. This reduces axial movement. The side stays should be installed and attached to the hull framework.

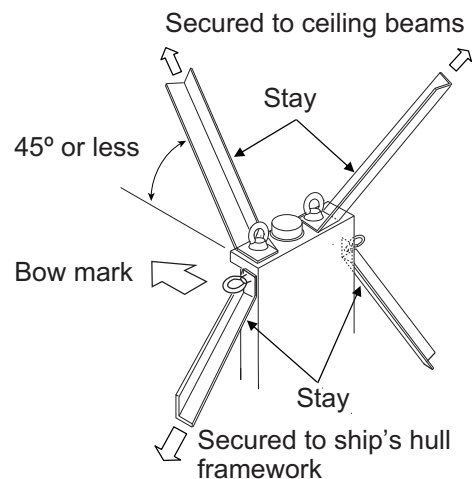

Non-horizontal stay installation

Shackle holes

When transporting the hull unit in a horizontal manner, use the shackle holes shown in the figure to the right. Attach shackles to the holes, then use block and tackle or chain, attached to the shackles, to move the hull unit.

Note: Once the hull unit is set in place, remove the shackles and ropes. Also, when removing the metal fittings on the cables wrapped around the hull unit, remove the cables.

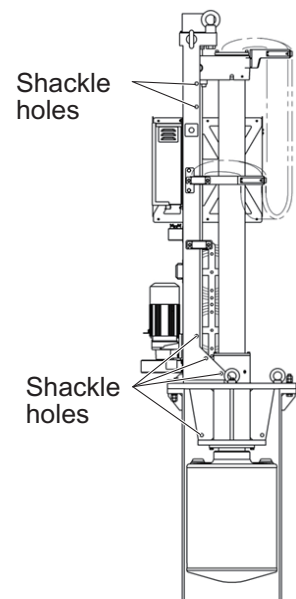

1.2 Processor Unit (FSV-2503/FSV-2503S)

1.2.1 Installation considerations

When selecting a mounting location, keep the following points in mind:

- Mount the unit upright (connectors facing downwards), or horizontal.
- Locate the unit out of direct sunlight and away from heat sources because of heat that can build up inside the unit.
The maximum normal operating temperature for this equipment is +45°C.
- Install the unit away from areas subject to water splash or rain.
- Be sure the mounting location is strong enough to support the weight of the unit under the continued vibration which is normally experienced on the ship.
If necessary reinforce the mounting location.
- Determine the mounting location considering the length of these cables:
 - Signal cable from the transceiver unit.
 - control cable from the control unit.
- Leave sufficient space on the sides of the unit to facilitate maintenance. Also, leave a foot or so of "service loop" in cables for servicing or easy removal of connectors. See the outline drawing at the back of this manual for recommended maintenance space.
- Follow the compass safe distances in the "SAFETY INSTRUCTIONS" on page i to prevent interference to a magnetic compass.

1.2.2 How to install the processor unit

The processor unit should be installed either on a desktop or a bulkhead.

Desktop installation

Fasten the unit with self-tapping screws (6×30, 4 pcs.).

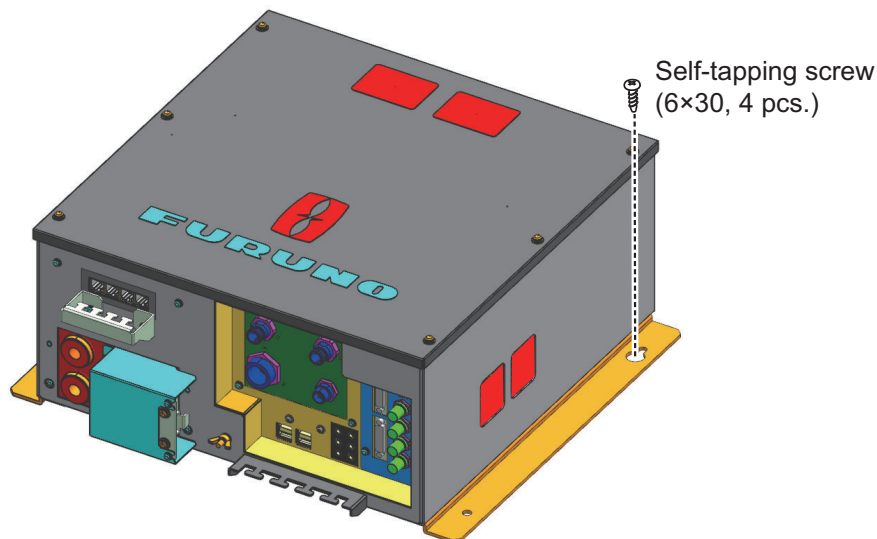

1. HOW TO INSTALL THE SYSTEM

Bulkhead installation

1. Mark locations for four self-tapping screws on the installation location.
2. Insert self-tapping screws ($\phi 6 \times 30$, 2 pcs., supplied) at the top two screw holes, leaving approx. 5 mm of the screws exposed.
3. Hang the processor unit on the two screws inserted at step 2.
4. Insert two self-tapping screws at the bottom of the unit.
5. Fasten all screws.

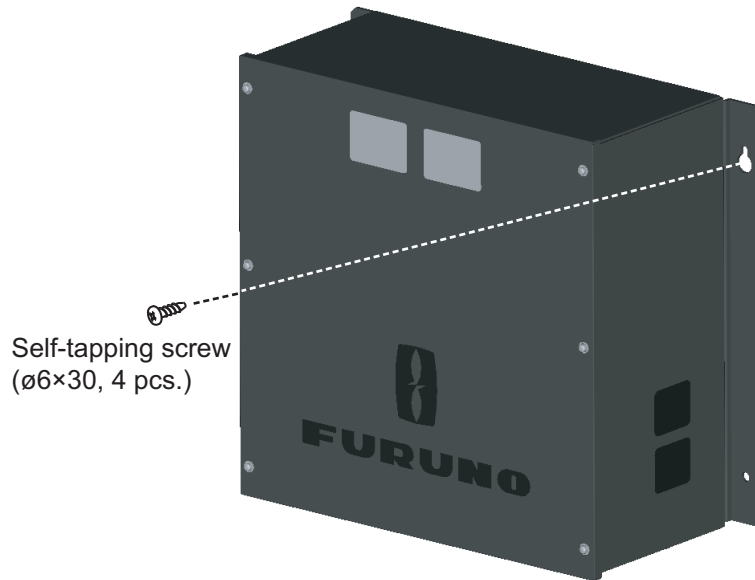

Note: Do not install the processor with the connectors facing upwards. Refer to the figure shown below for recommended installation.

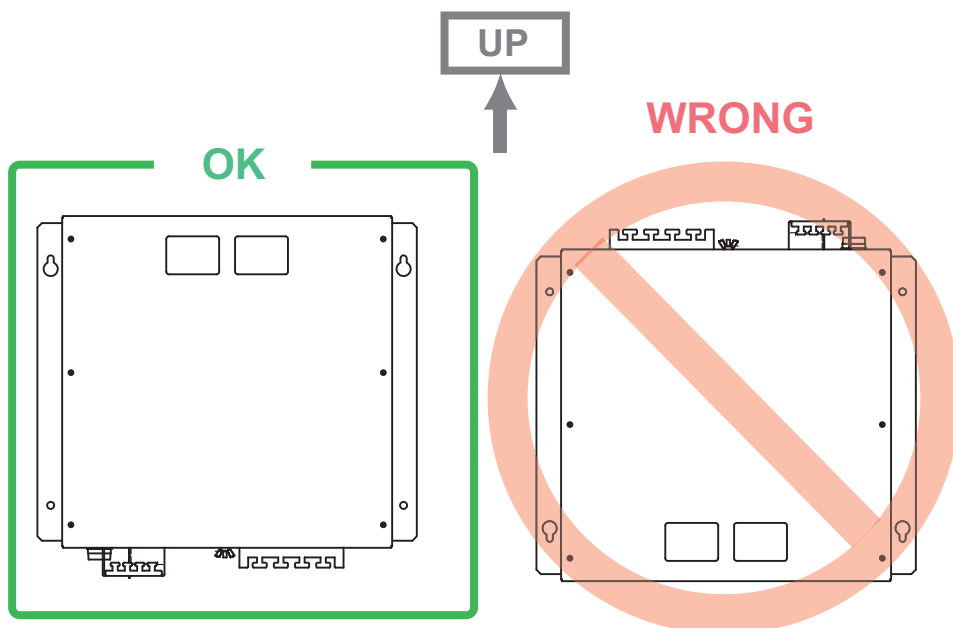

1.3 Control Unit (FSV-2501)

The control unit can be installed in a console (flush mount) or on a desktop (with KB fixture). Select a location considering the following points.

- Select a location where the controls can be easily operated.
- Locate the unit away from direct sunlight.
- Keep the unit away from water and water splash
- The length of the cable connected between the control unit and interface unit is 5 or 10 m. Select a location considering the length of the cable.
- Observe the compass safe distance (see "SAFETY INSTRUCTIONS" on page i) to prevent interference to a magnetic compass.

1.3.1 How to install the control unit

Desktop installation, with KB fixture

1. Fasten the KB fixture to the selected location with self-tapping screws ($\phi 5 \times 20$, 4 pcs.).

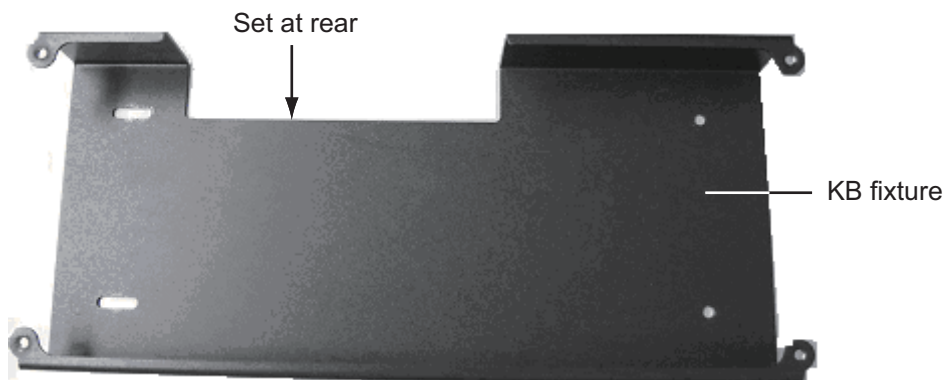

2. Connect a ground wire (1.25 sq., local supply) between the ground terminal at the bottom of the unit and ship's ground.
3. Set the unit on top of the KB fixture and fasten the unit with four binding screws (M5x12) and wave washers.
4. Set the cosmetic caps to the fixing holes.

1. HOW TO INSTALL THE SYSTEM

Flush mount

1. Prepare a hole in the mounting location referring to outline drawing shown below.

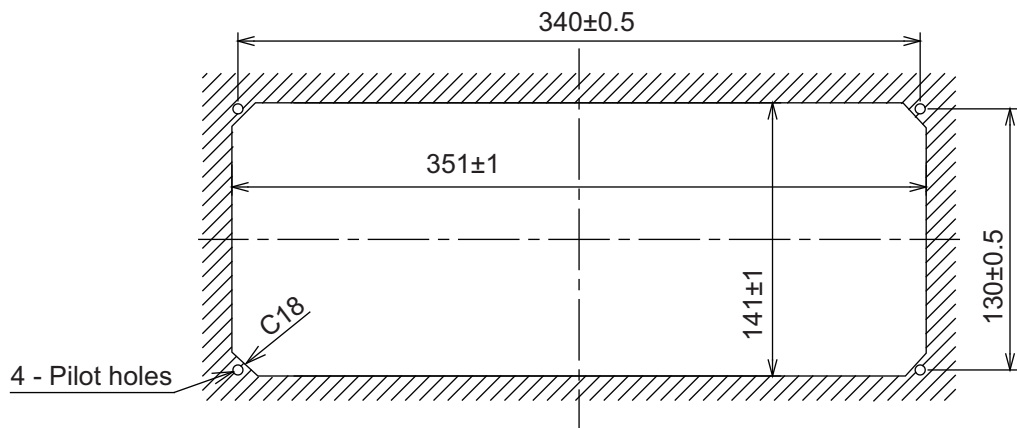

2. Make four pilot holes for self-tapping screws ($\phi 5$).
3. Peel the tape from the Flush mount gasket then attach the gasket to the rear of the control unit.
4. Set the unit to the hole and fasten it with self-tapping screws ($\phi 5 \times 20$, 4 pcs.) and wave washers.
5. Connect a ground wire (1.25 sq., local supply) between the ground terminal at the bottom of the unit and ship's ground.
6. Set cosmetic caps to the fixing holes.

1.3.2 Control Unit FSV-853 (option)

Desktop installation, with keyboard fixture

Name	Type	Code No.	Qty
Keyboard fixture	03-163-7821-1	100-306-291-10	1
Washer head screw	M4×12 C2700W MBN12	000-163-192-10	6
Rubber foot	M5×40	000-162-682-10	2

1. Fix the keyboard fixture to the bottom of the unit with the screws (M4×12) supplied.
2. Attach rubber feet (2 pcs.) to the bottom of the unit.
3. Fix the unit to the mounting location with self-tapping screws (local supply).

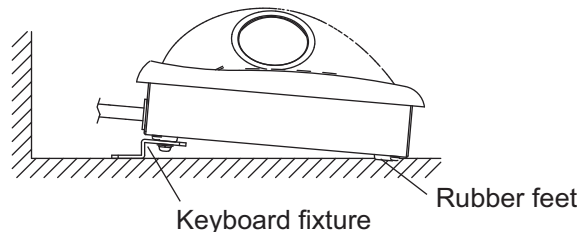

Desktop installation, no keyboard fixture

1. Drill four mounting holes of 5 mm diameter, referring to the outline drawing at the back of this manual.
2. Fix the unit with screws (M4, 4 pcs.) from under side of the desktop. (Supply the screws locally. Make sure the screws are of a sufficient length for the thickness of the desktop.)

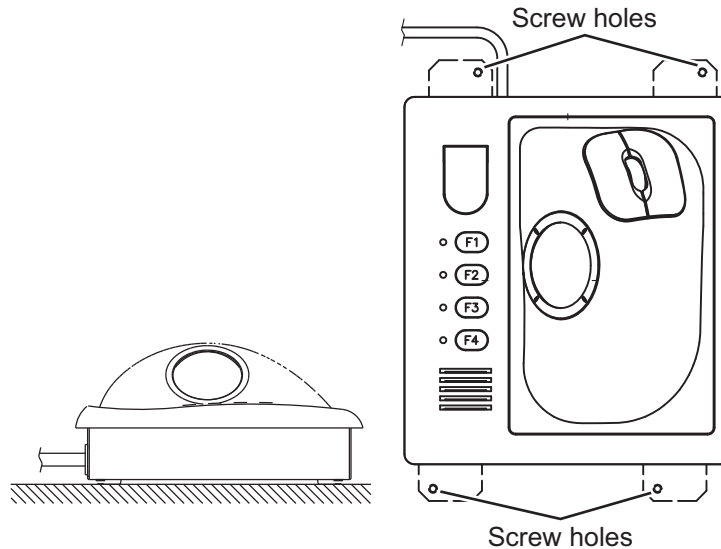
**Flush mount (option)**

Use the optional flush mount kit (Type: FP03-09870, Code No.: 008-535-630) to mount the sub control unit.

Name	Type	Code No.	Qty
Mounting plate	03-163-7531	100-306-261	4
Hex nut	M5	000-863-108	4
Wing screw	M5×40	000-162-682-10	4
Pan head screw	M4×12	000-163-192-10	4

1. Prepare a hole in the mounting location referring to the outline drawing at the back of this manual.
2. Set the unit to the hole.
3. Attach the mounting plate to the unit with four screws from the rear side.
4. Screw the wing screw to each mounting plate and then insert hex bolt to each wing screw.
5. Fasten each wing screw and then fasten the hex nuts.

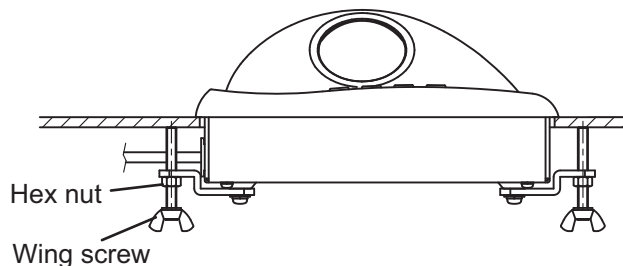

1.4 Transceiver Unit (FSV-251)

Select a mounting location considering that the effective length of the cable between the transceiver unit and the hull unit is 10 m (standard).

The transceiver unit should be fixed to a mounting base (shipyard supply) whose dimensions are as shown in the outline drawing at the back of this manual.

Reinforce the transceiver unit against vibration by following the procedure below.

1. Attach the anti-vibration device (2 pcs.) to the mounting base using M12 bolts and nuts (4 pcs, local supply). Insert the bolts from the top of the fixing plate.

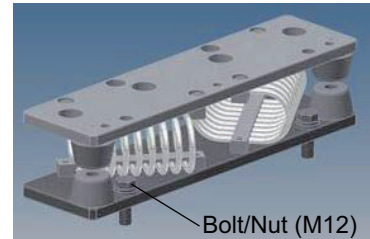

2. Place the transceiver feet on the anti-vibration devices.

Note: Keep the transceiver unit level with horizontal line when the feet are placed on the anti-vibration devices. If the unit is placed on the anti-vibration device correctly, the stoppers (4 locations) should be separated by a gap of approx. 10 mm.

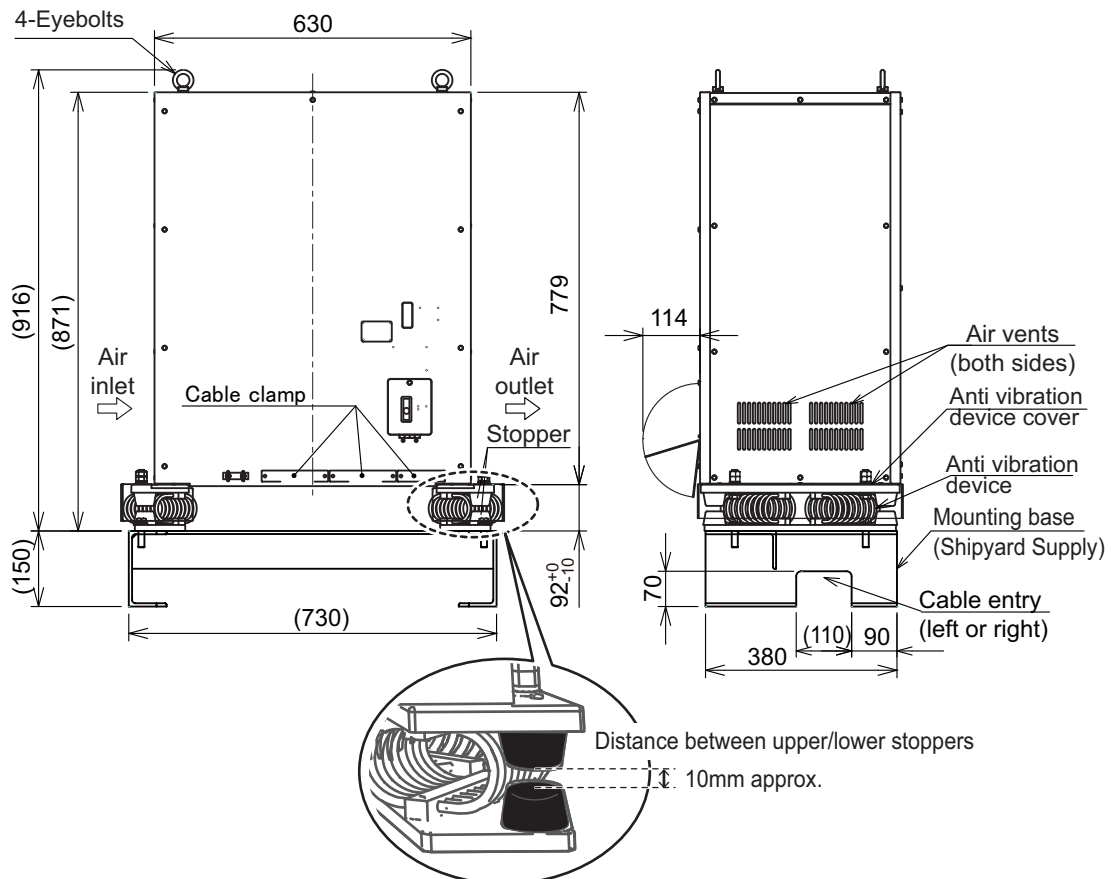

3. Fix the transceiver unit to the anti-vibration devices with M12x50 hex bolts, spring washers, plain washers and 2 x nuts (supplied). Insert the bolts from the bottom of the fixing plate.

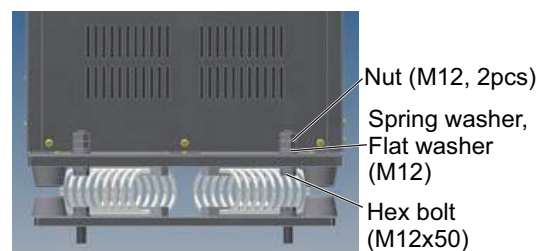

4. Using ropes (local supply), connect the eye-bolts to the ceiling or bulkhead.

Note: The transceiver sways with the ship's roll or pitch. When the ship moves suddenly from wave impact or other causes, the transceiver unit may sway farther than the stoppers. This can cause damage to the anti-vibration device. To prevent damage to the anti-vibration device and the transceiver unit, secure the transceiver unit with ropes in the manner shown below.

- 1) When a ceiling is available above the transceiver unit, prepare four anchor points (use locally supplied fixtures) for the ropes. When a ceiling is not available above the transceiver unit, prepare a frame (use locally supplied materials) which can be mounted to the bulkhead above the transceiver unit. The frame should have four anchor points for the ropes.

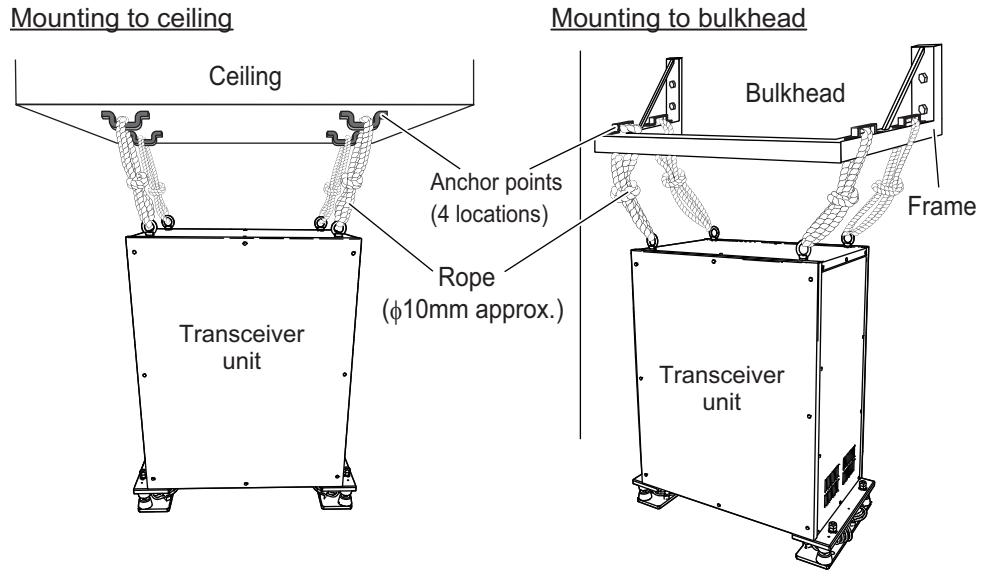

- 2) Connect the eye-bolts at the top of the transducer unit to the anchor points with rope.
- 3) Adjust the rope length to allow the transducer unit to sway forward and backward. Push, or pull, the transceiver unit so that the stoppers on the anti-vibration device meet, then tighten the rope.

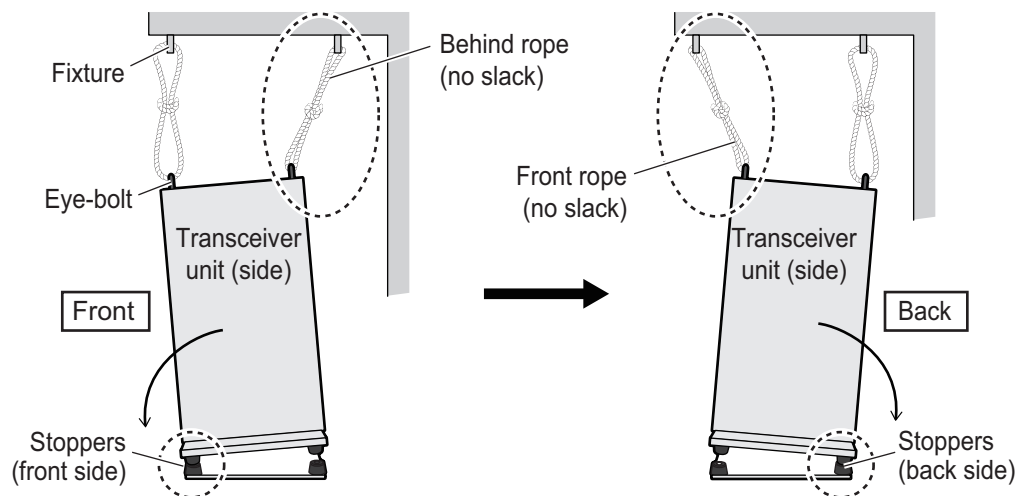

1. Pull the transceiver unit toward front, then adjust the behind rope length so that the front side stoppers are touched.

2. Push the transceiver unit toward back, then adjust the front rope length so that the back side stoppers are touched.

1. HOW TO INSTALL THE SYSTEM

- Place the anti-vibration device covers over the transceiver base, then secure the covers to the anti-vibration devices using the M4x8 bolts (supplied).

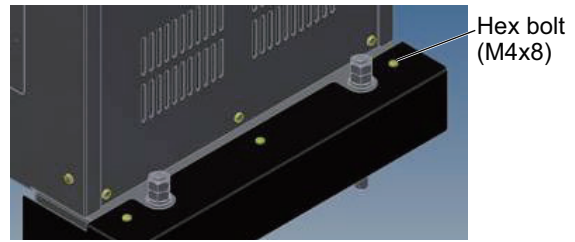

1.5 Power Supply Unit (FSV-252)

The power supply unit (FSV-252) for the transceiver unit can be mounted in two manners, wall mount or deck mount. Fasten the FSV-252 in the mounting location using four M10 bolts (local supply). The floor mount location should be a horizontal plane. Adjust the air vents on the sides of the unit so the vent openings are facing downwards.

Be sure the mounting location is strong enough to support the weight of the unit under the continued vibration which is normally experienced on the ship. If necessary reinforce the mounting location.

Note 1: Do not mount or place the FSV-252 on the transceiver unit.

Note 2: Make sure the FSV-252 is mounted with the cable entry points facing down.

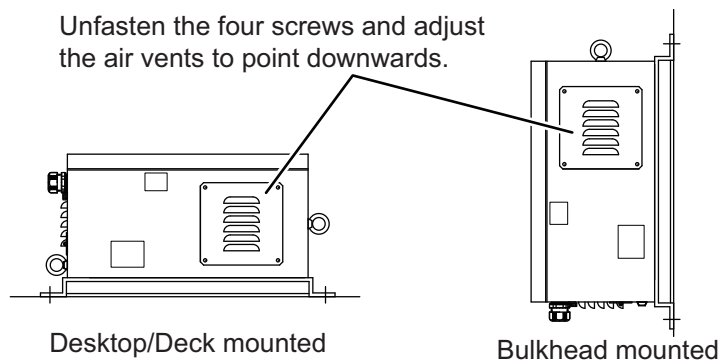

Suspending the FSV-252 (when using a crane, etc.)

The FSV-252 weighs approximately 37.5 kg. The attached eye-bolts are used when hanging the FSV-252. Only suspend the FSV-252 upside down when moving it, do not install the FSV-252 upside down. Use the figure below for reference.

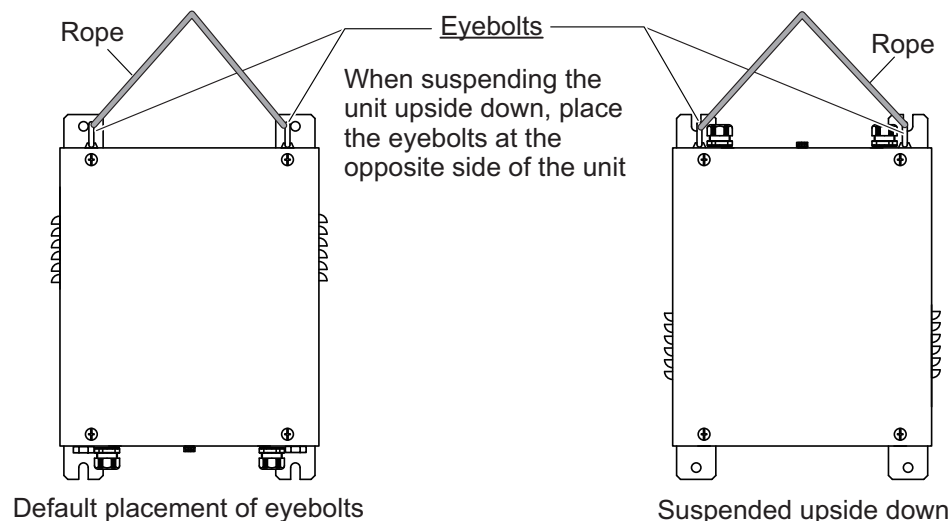

1.6 IF (Interface) Unit (FSV-8502)

Refer to the outline drawing at the back of this manual for mounting dimensions. Fasten the unit with $\phi 5 \times 20$ self-tapping screws. If the unit is to be installed on a bulkhead, be sure that the location does not allow water to drip into the cable entrance.

1.7 Junction Box (FSV-2550)

A junction box must be installed between the transceiver and the hull unit. Referring to the outline drawings at the back of this manual for dimensions, install the junction box on the hull unit stand where possible. Where installation on the hull unit stand is not possible, install the junction box securely on a wall or bulkhead using M10 bolts (6 pcs., supplied). When installing the junction box to the hull unit, use M12 bolts (6 pcs., supplied).

1.8 Raise/Lower Control Box (FSV-2530)

The inertial measurement unit is installed in the raise/lower control box. When using the control box extension box (FSV-2560), remove the two fans from the raise/lower control box and install them in the control box extension box. Install the inertial measurement unit in the control box extension box, then secure the control box extension box to the hull unit.

How to attach the raise/lower control box to a bulkhead

When using the control box extension box, the raise/lower control box can only be installed on a bulkhead. Use 4×M10 bolts to fasten the raise/lower control box in position.

The internal electromagnetic switches only function correctly if the raise/lower control box is installed in the correct orientation, as shown in the figure below.

Note 1: When installing the inertial measurement unit inside the raise/lower control box, you must enter the location and angle of the raise/lower control box for heading correction. (See section 3.5 for how to adjust the heading.)

Note 2: The inertial measurement unit must be installed inside the control box extension box. The unit is extremely shock sensitive, take care not to drop it. Where possible, install the unit after the control box extension box has been installed.

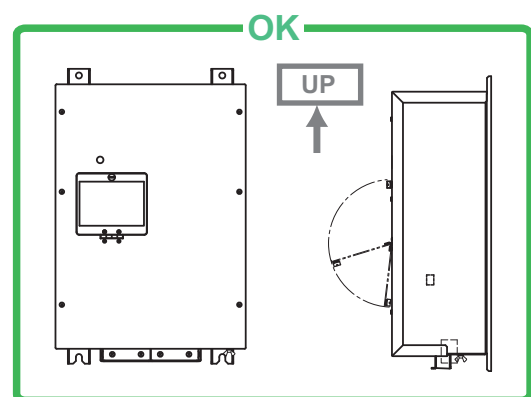

1.9 Control Box Extension Box (FSV-2560)

To install the optional control box extension box, do the following.

1. Unfasten the M10 bolts (4 pcs.) connecting the raise/lower control box to the hull unit.
2. Disconnect the raise/lower control box cabling, then connect the cables to the control box extension box.
3. Install the extension box in the location the raise/lower control box originally was installed, using the M10 bolts (4 pcs.) unfastened in step 1.

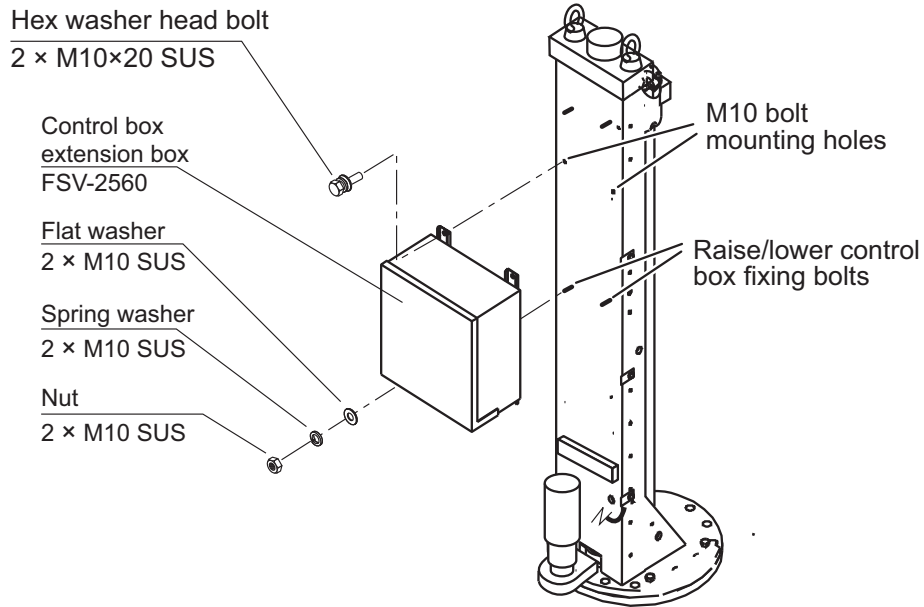

1.10 Attachment Flange (Option)

When retrofitting a CSH-20 or FSV-24/30/35 hull unit on a steel hull, an attachment flange must be used. Choose the correct flange from the table below, using the length of the pre-installed tank to determine the raising height.

Flange type	Raising height (mm)
OP10-42	150
OP10-38	200
OP10-39	250
OP10-43	280
OP10-44	315

When retrofitting CSH or FSV-243E/244E hull units, use the OP10-24 attachment kit.

Attachment kit OP10-24 contents (Code No.: 006-943-530)

Item	Type	Code No.	Qty
Insulated gaskets (1)	MS-1000-67-1	100-347-601-10	24
Insulated gaskets (2)	MS-1000-68-1	100-347-611-10	24

1. Clean the flange and O-ring groove of the retraction tank (welded to hull) with ethyl alcohol moistened waste cloths.
2. Apply lithium grease to the O-ring and O-ring groove. Place the O-ring in its groove on the tank flange.
3. When using Attachment Kit OP10-24, lay the insulation gaskets (1) on the top of the tank flange, taking care to align the bolt holes on the gaskets with the bolt holes on the flange.
4. Confirm the following points as below and place the attachment flange on the retraction tank.
 - Clean the flange platform.
 - Wipe the undersurface of the attachment flange with clean waste cloths.
 - Keep O-ring in its position.
5. When using Attachment Kit OP10-24, insert the insulation gaskets (2) into the bolt holes of the tank flange.

1. HOW TO INSTALL THE SYSTEM

6. Apply a slight amount of lithium grease to the threads of the bolts to prevent scorching. Insert the bolts with washers from the retraction tank flange, and then put the flat washers and spring washers in this order from above. Fasten bolts with nuts.

Attachment flange OP-38/39/43/44

When retrofitting CSH series or FSV-243E/244E, use the insulated gasket from the Attachment kit OP10-24

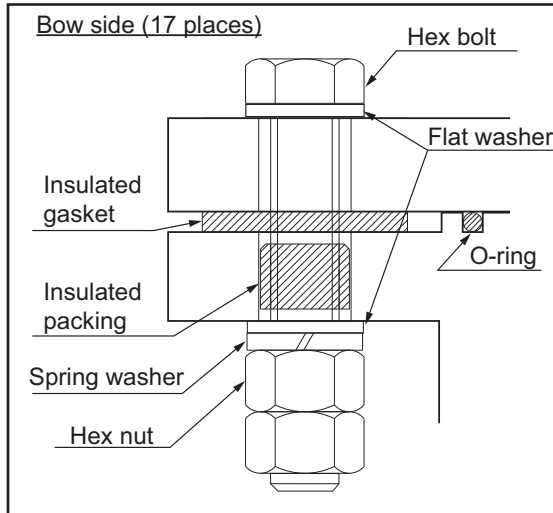

Stern side (7 places) is secured using stud bolts, flat washers, spring washers and 2 x hex nuts.

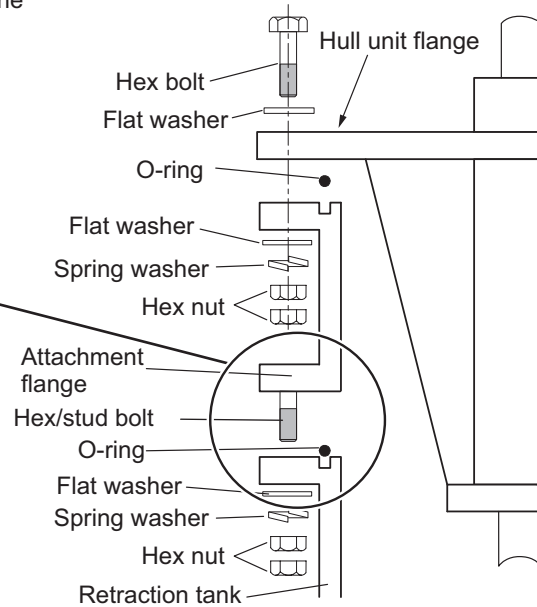

7. Reinforce the attachment flange using reinforcement ribs.

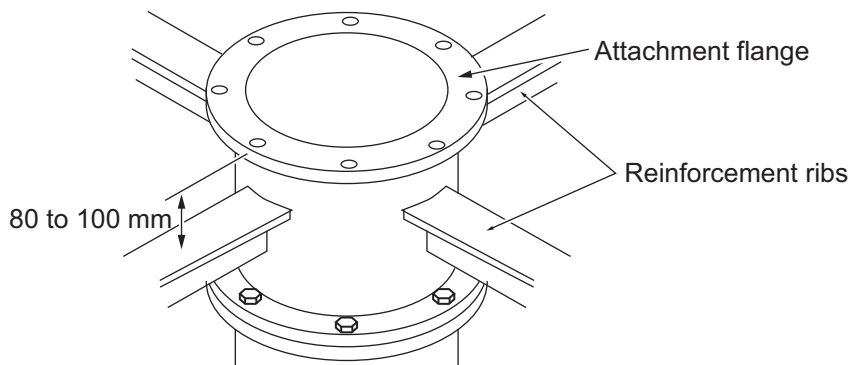

Note: For installations requiring welding of the reinforcement ribs:

- 1) Temporarily remove the insulated gasket, insulated packing and O-ring.
- 2) Temporarily install the attachment flange, then install and weld the reinforcement ribs.
- 3) Remove the attachment flange, then replace the insulated gasket, insulated packing and O-ring.
- 4) Follow step 6 above.

1.11 Remote Controller (FSV-2504)

Use the optional fixing material (Type: OP10-9, code no. 006-990-040) to install the optional remote controller in a location away from spray and splash. Use the outline drawing at the back of this manual for reference.

2. WIRING

2.1 How to Connect the Units

FSV-25 Interconnections

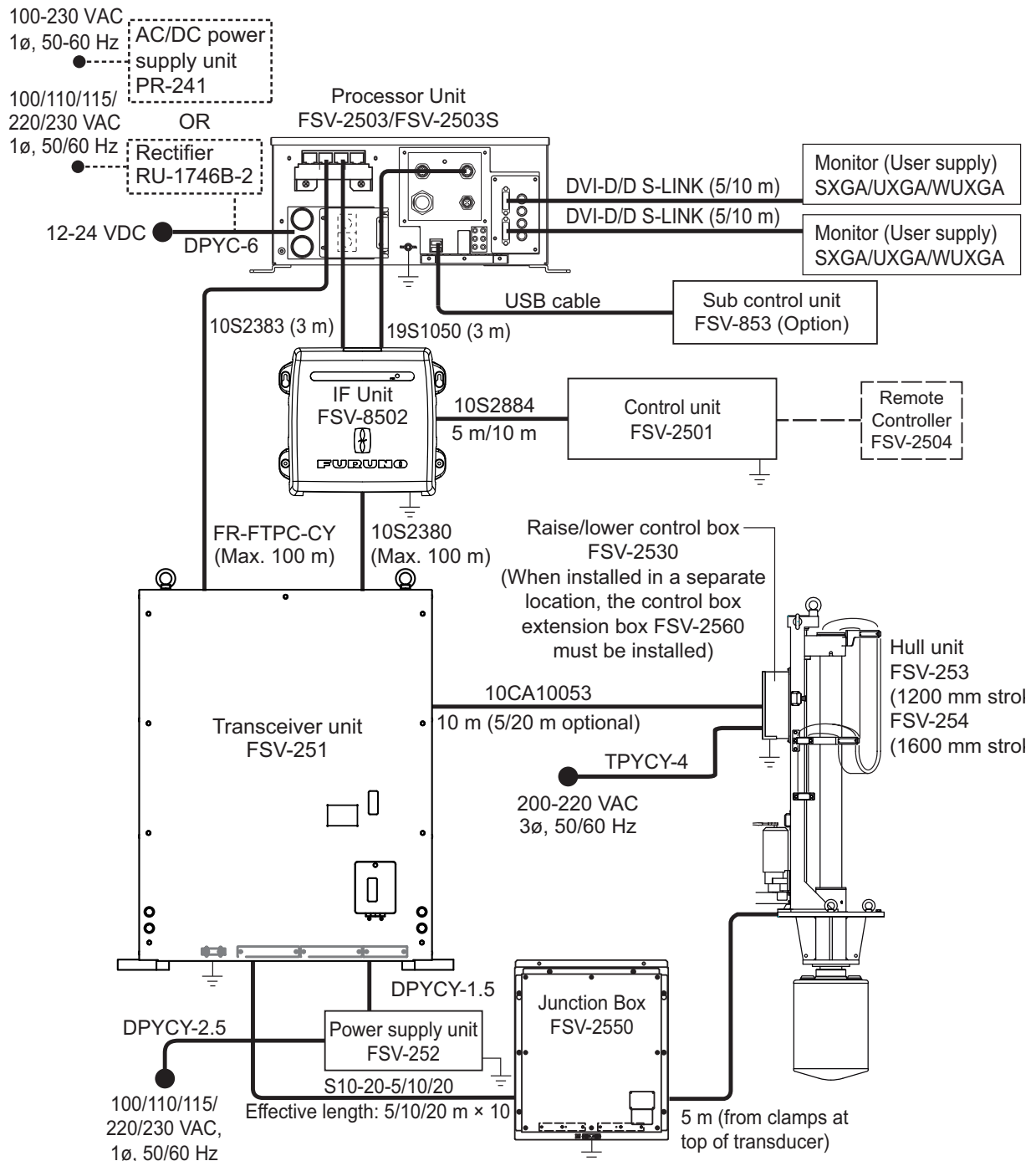

Installation of equipment

The processor unit, transceiver unit, power supply unit and hull unit must have a protective earth. Use a ground wire (1V-8sq., local supply) or a ground plate. A ground strap is supplied with the transceiver unit and power supply unit.

Transducer cable

- The transducer cables (S10-20/10/20, 10 pcs) are secured on the cable securing plate. After installation of the hull unit, release the transducer cables from the cable securing plate for wiring. The cable securing plate can be removed and discarded after releasing the transducer cables.

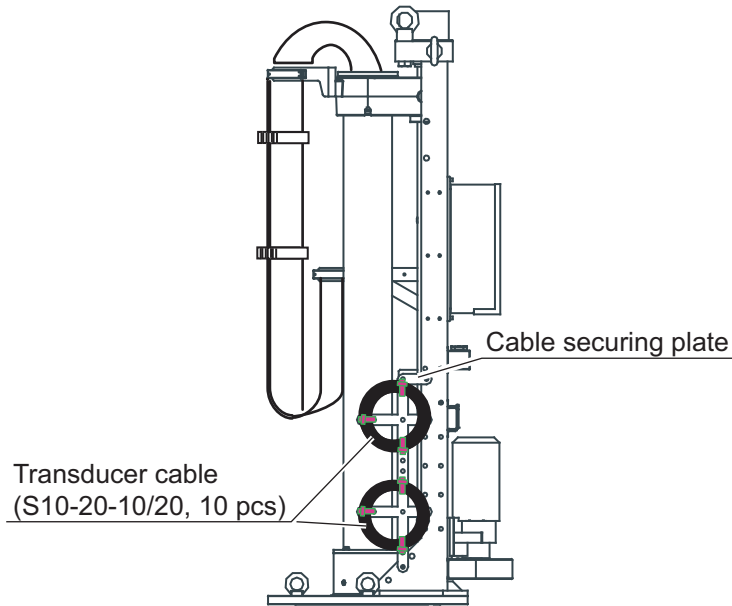

- When the transducer is removed from the hull unit while installing the hull unit, re-attach the transducer and route the transducer cables as shown in the following figure.

Transducer cable routing layout

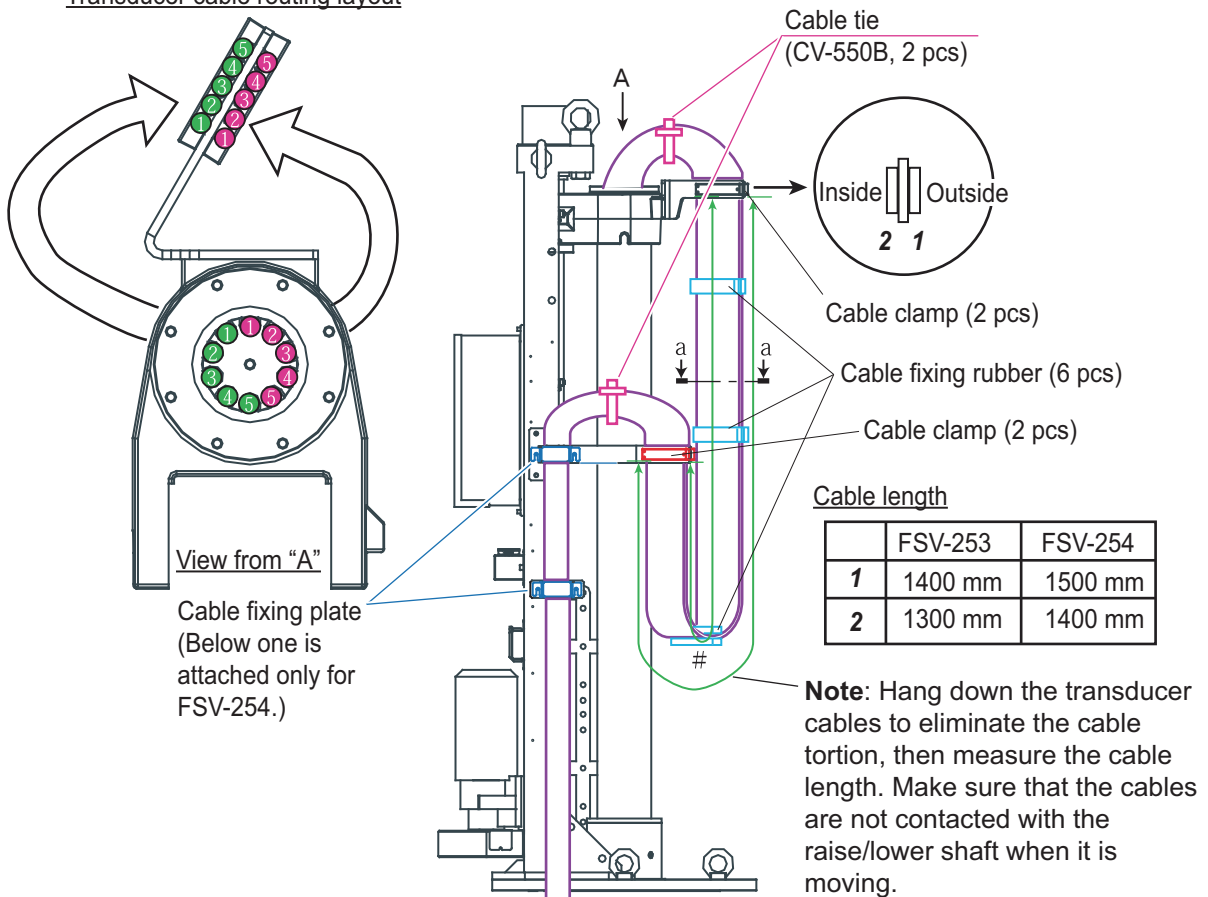

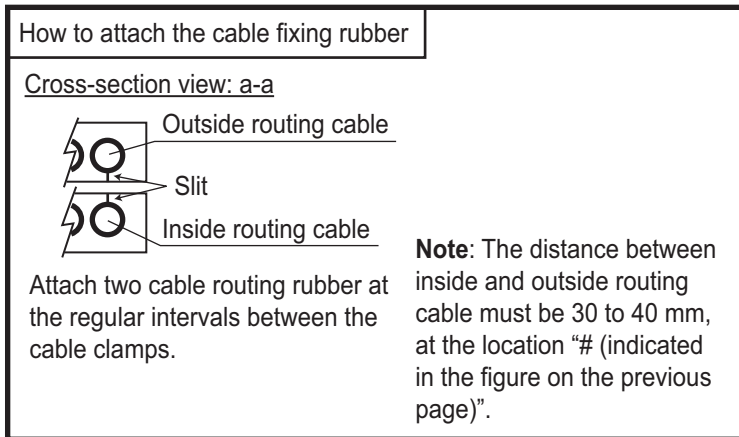
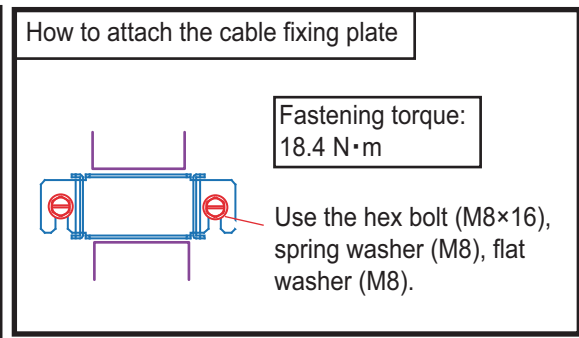
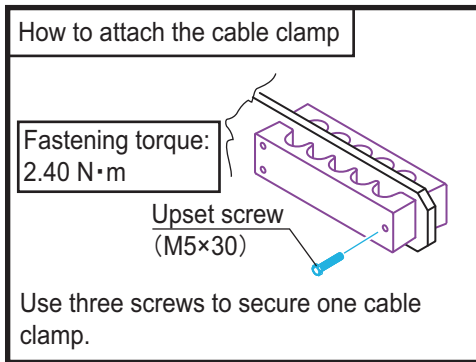

2.2 Processor Unit

Referring to the figure below, connect external units to the processor unit via the front panel of the processor unit. Make sure all cables are securely connected.

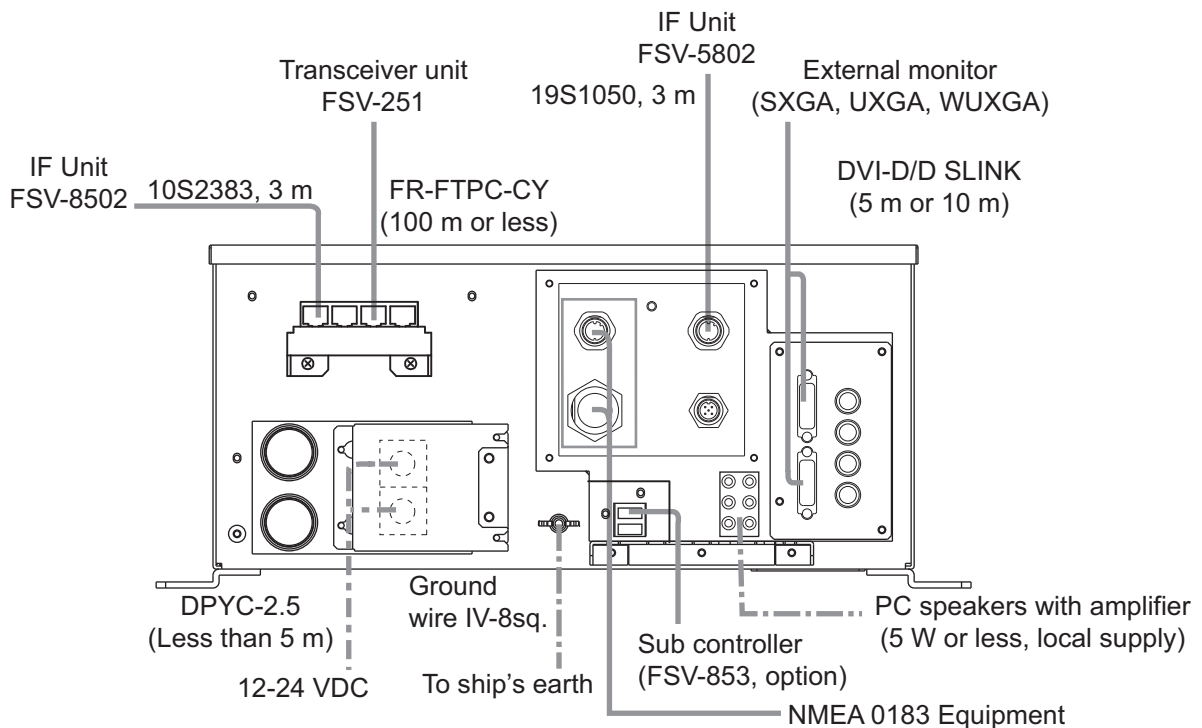

2. WIRING

Power cable fabrication

1. Referring to the figure below, fabricate a DPYC-6 marine power cable (Maximum length 5m, local supply.)
2. Remove the power terminal cover at the rear of the processor unit (See figure below), then connect the DPYC-6 power cable. (Upper terminal is +, lower terminal is -.)
3. Replace the power terminal cover to its original position.
4. Connect the processor unit earth to the ship's earth with a ground wire (IV-8.sq, local supply).

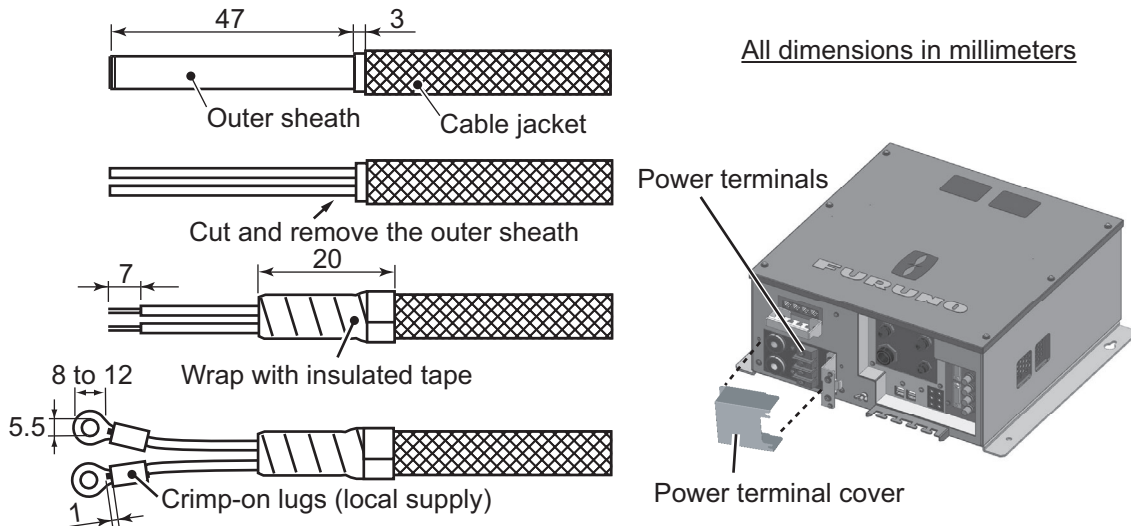

LAN cable fabrication

Choose the correct length cable from the supplied LAN cables (Type: FR-FTPC-CY, lengths: 10 m, 20 m, 30 m, 50 m, 100 m), then prepare the cables as shown below.

After preparing the cable attach the modular connectors as follows.

Preparing the LAN cable ends

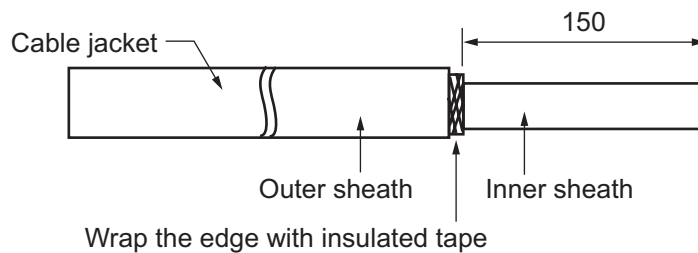



Expose inner vinyl sheath.

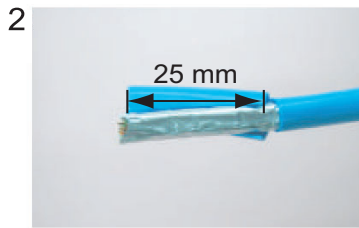

Remove the inner vinyl sheath by approx. 25 mm. Be careful not to damage inner shield and cores.

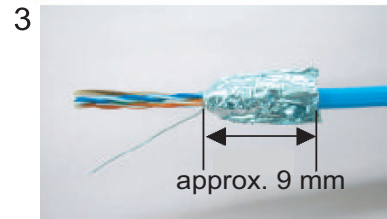

Fold back the shield, wrap it onto the inner vinyl sheath and cut it, leaving approx. 9 mm.

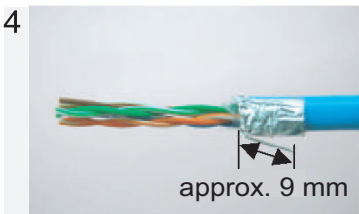

Fold back drain wire and cut it, leaving approx. 9 mm.

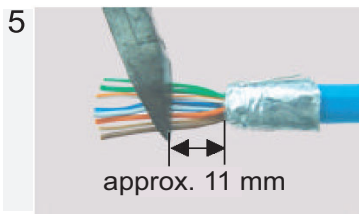

Straighten and flatten the cores in colored order and cut them, leaving approx. 11 mm.

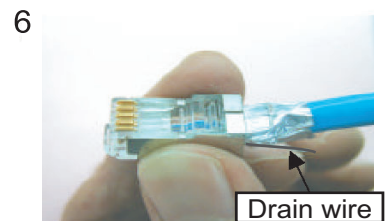

Insert the cable into the modular plug so that the folded part of the shield enters into the plug housing. The drain wire should be located on the tab side of the jack.



Using special crimping tool MPT5-8AS (PANDUIT CORP.), crimp the modular plug. Finally, check the plug visually.

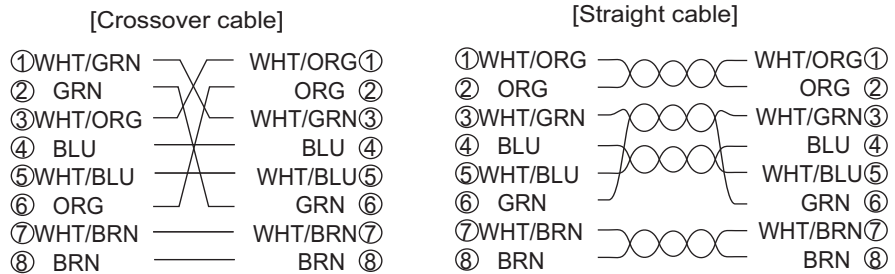
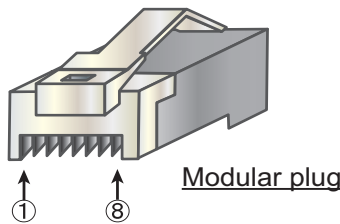

2. WIRING

How to extend length of cable for external monitor

If the distance from the control unit to the monitor is more than 10 m, follow the procedure below to lengthen the cable, up to 70 m. The video output is analog so use an analog monitor. Use of cables other than those listed below can result in poor picture quality. A DVI-RGB adapter (local supply) may be necessary.

Part	Type	Code No., Maker	Qty	Remarks
Coaxial cable	1.5C2V-3C2V-T-20M	000-164-049-10	1	20 m
	1.5C2V-3C2V-T-30M	000-164-050-10		30 m
	1.5C2V-3C2V-T-70M	000-164-051-10		70 m
Connector assy.	BNCX5-DSUB15-L400	000-159-595-10	2	
BNC connector	BNC-P-3	000-500-396	6	For 3C-2V
	BNC-P-1.5V-CR	DDK	4	Recommended
DVI Adapter	AD-D15FTDVM	Elecom	1	Recommended, DSUB-15 pin, female

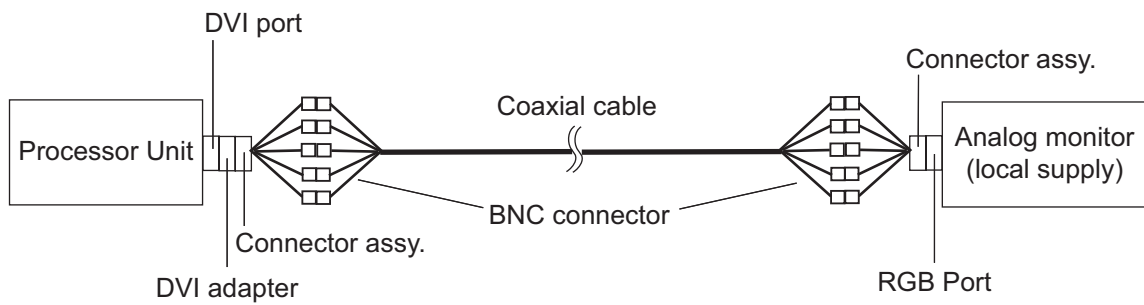

2.3 IF Unit

The IF unit installs between the processor unit and the transceiver unit. Connect the cables according to the diagram inscribed on the shield cover of the IF unit. JIS cables and FURUNO cables are available for the connection. To connect the JIS cables, use the larger cable holes as shown below.

Connect the processor unit earth to the ship's earth with a ground cable (IV-2sq., local supply).

Select a location that provides the maintenance space prescribed in the outline drawing. Follow the compass safety distance in the "SAFETY INSTRUCTIONS" to prevent interference to a magnetic compass.

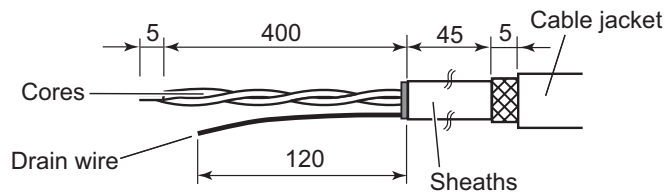
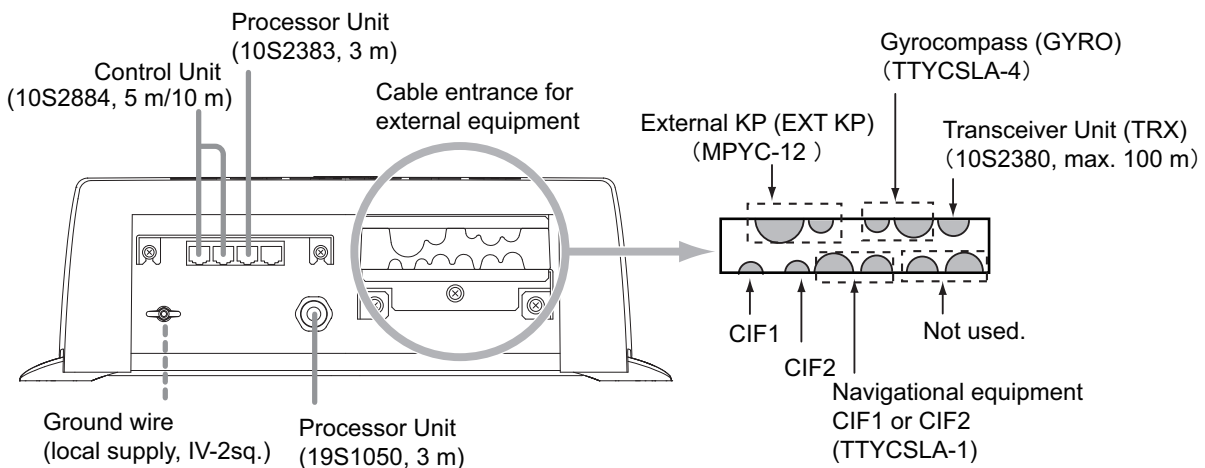

How to fabricate the cables

TTYCSLA-1/4

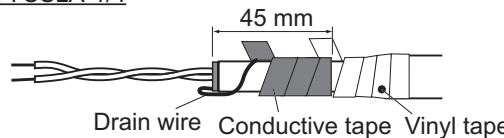

Wrap the drain wire around the outer sheath and secure it with insulated tape. Secure the sheaths and cable jacket with vinyl tape.

Cables for FURUNO CIF1 equipment

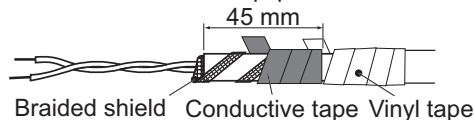

Wrap braided shield around vinyl sheath.
Cover braided shield with conductive fabric tape.

Retrofitting

When retrofitting units such as the FSV-30, the cables from the IF unit to the Transceiver can be substituted with 10S1258 cables. Check the cables are twisted pairs and each pin signal is correctly wired. Clamp the cable shields to the respective unit's cable clamps. Make sure the cables are not bent or damaged.

How to connect external KP

To synchronize transmission with external sonar, make the connections shown below.

Current drive KP output

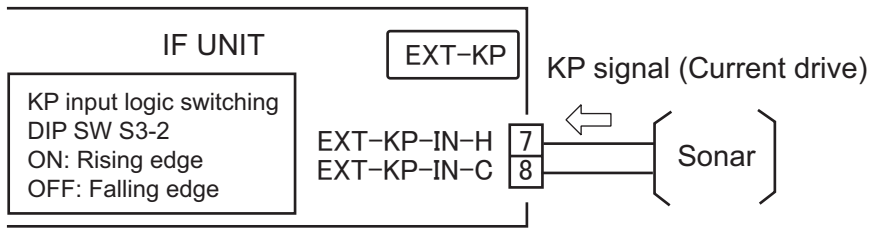

Voltage drive KP output

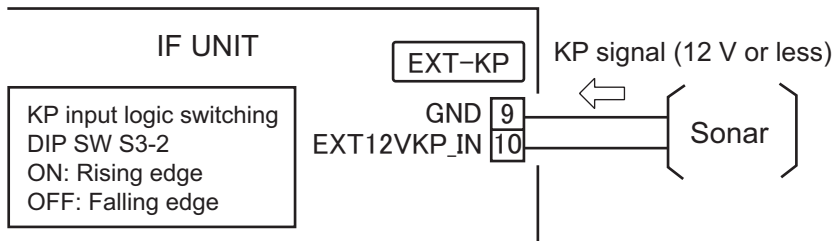

Make the connections shown below to output KP for external sonars and current indicators. This sonar transmits a keying pulse (KP) to connected external sensors when this sonar is connected and running.

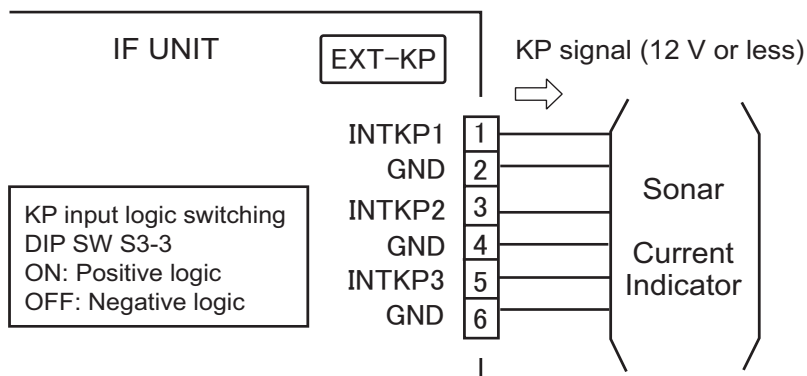

2.4 Control Unit and Remote Controller

Ground

Connect a IV-1.25 sq. ground wire (local supply) between the ground terminal on the control unit and the ship's ground.

How to connect the remote controller

Connect the optional remote controller (FSV-854) as shown below.

1. Unfasten the six pan head screws at the bottom of the control unit to detach the cover.

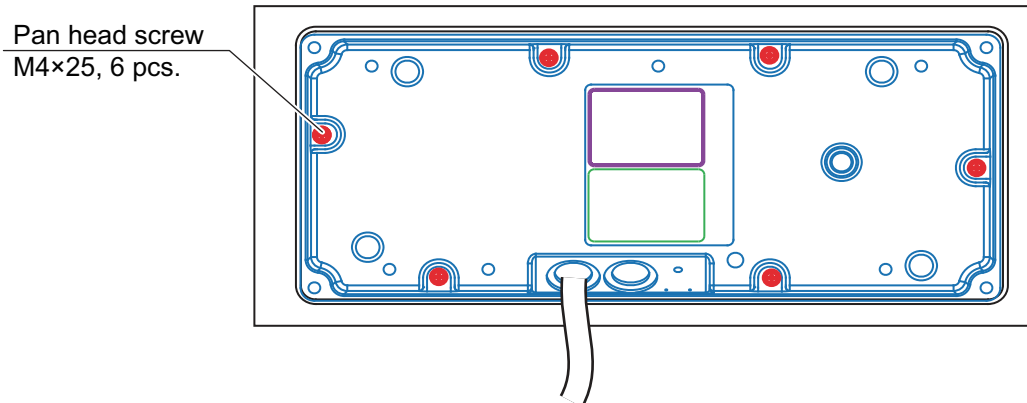

Rear side of the control unit (cover removed)

2. Cut a cross in the grommet on the cover then pass the remote controller cable through the grommet.

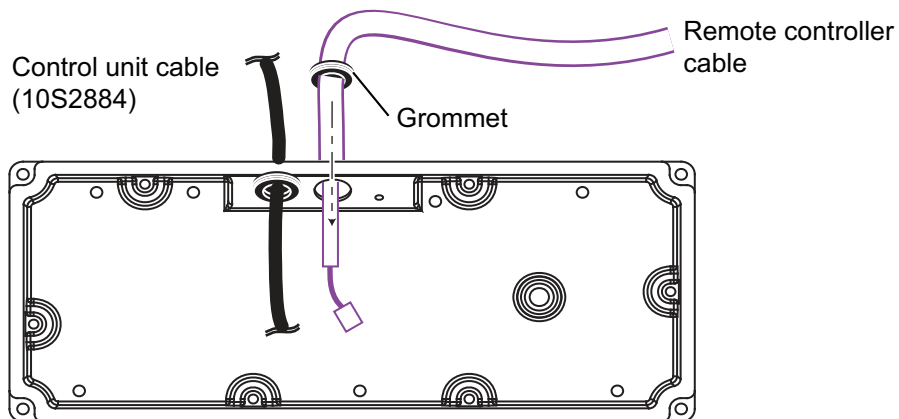

Rear side of the control unit (cover removed)

2. WIRING

3. Connect the remote controller cable to J2 on the control unit and use the support plate to fix the cable.

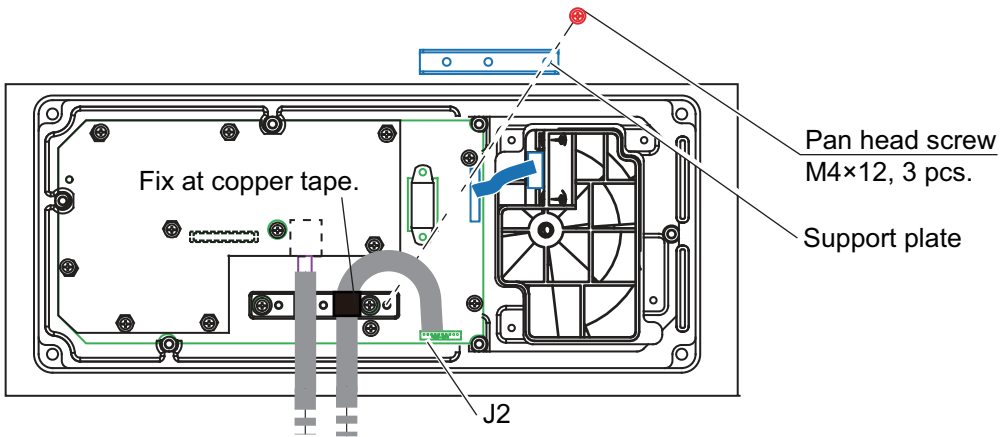

Rear side of the control unit (cover removed)

4. Attach the cover.
5. At a distance of 1 cm from the control unit, attach the supplied EMI core (GRFC-6) to the remote controller cable.

How to connect No.2 control unit (option)

Two control units can be connected. On the No.2 control unit, remove the rear cover and set the DIP switch as shown below.

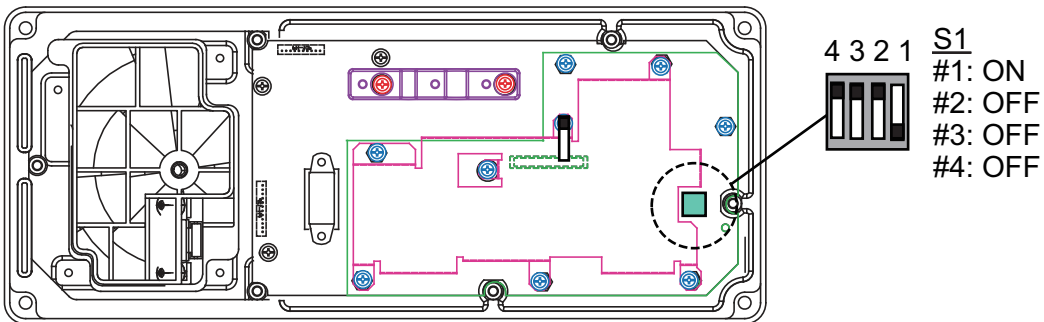

2.5 Transceiver Unit

2.5.1 How to connect the IF unit

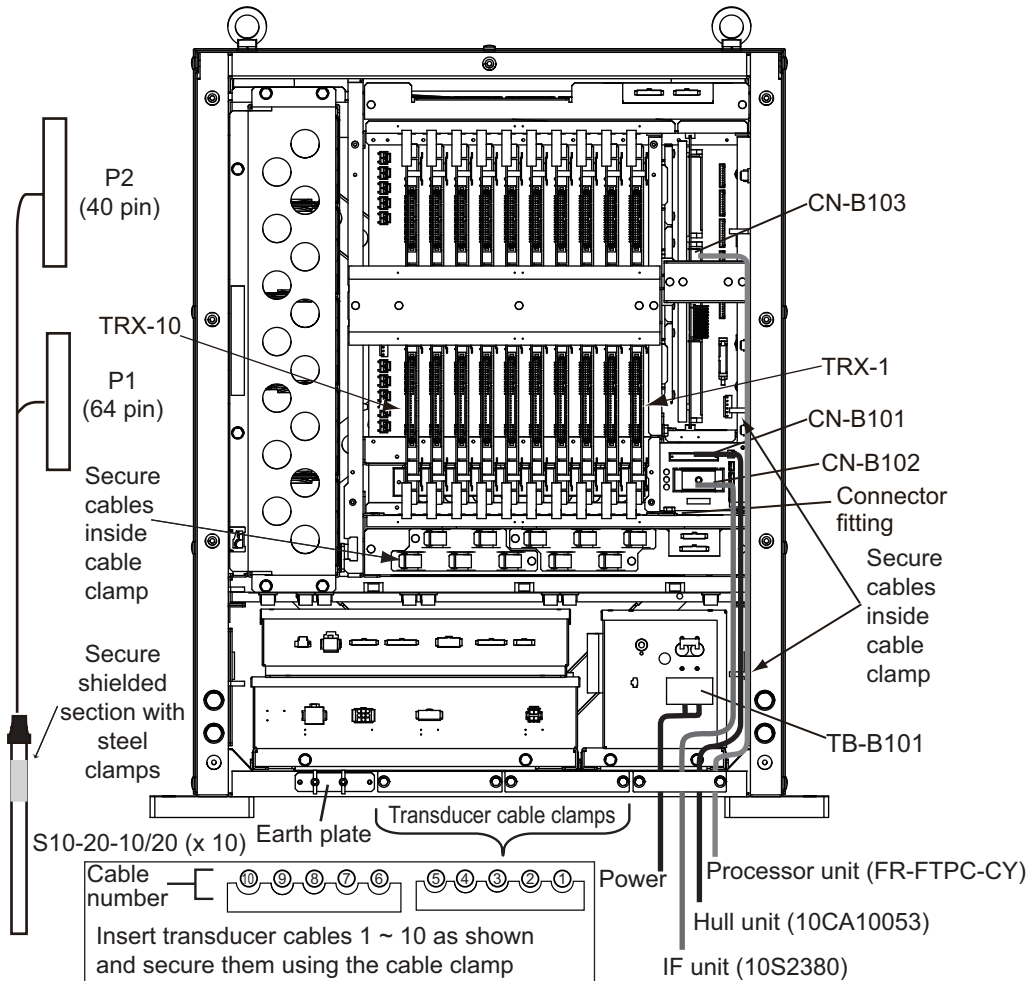

The transceiver unit is supplied with an earth plate (50 mm width, 1.5 m length) in the installation materials. Use the two wing nuts to secure the plate and connect the transceiver ground plate to the ship's earth.

Pass the IF unit cable (10S2380) through the cable clamp on the transceiver unit and attach the 14P connector (CN-B101).

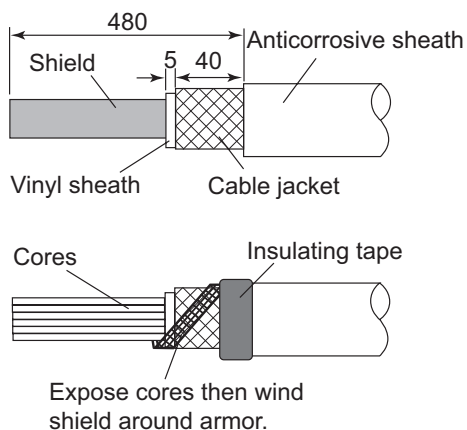

How to attach WAGO connectors

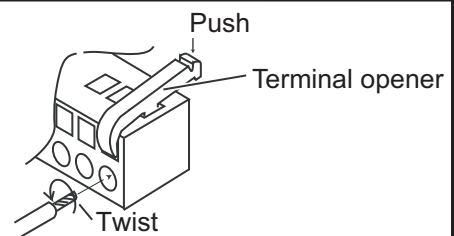

Procedure

1. Twist core.
2. Insert terminal opener and push.
3. Insert wire into hole.
4. Release terminal opener.
5. Pull wire to confirm it is correctly inserted.

2. WIRING

2.5.2 How to connect the transducer cables

1. Remove the transceiver unit cover.
2. Connect the cables from the transducer referring to the cable no. labeled on the chassis and connector no. labeled on each PC board. Connect the HIF connector of the cable from the junction box to the TRX board on the transceiver unit.
3. Arrange the cables in numerical order and fix them with the cable clamp.
4. Remove the metal fixing which secured the transducer cables to the hull unit.

2.5.3 How to connect the processor unit

Connect the LAN connector to the CN-B103 port.

2.5.4 Power cable

Connect the power cable DPYCY-1.5 (or equivalent) to TB-B101 of the transceiver unit. Fabricate the power cable as shown below.

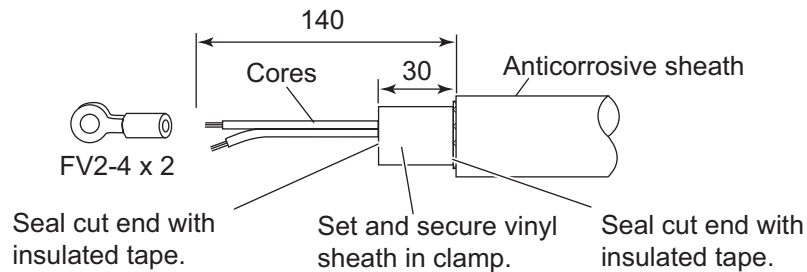

2.6 Junction Box

The junction box connects the transceiver to the hull unit using (10×) S10-19 cables from the transducer (hull unit) to the junction box and (10×) S10-20-5/10/20 cables from the junction box to the transceiver unit.

1. Remove the junction box cover.
2. Remove the cable clamp and the metal PC board clamp.

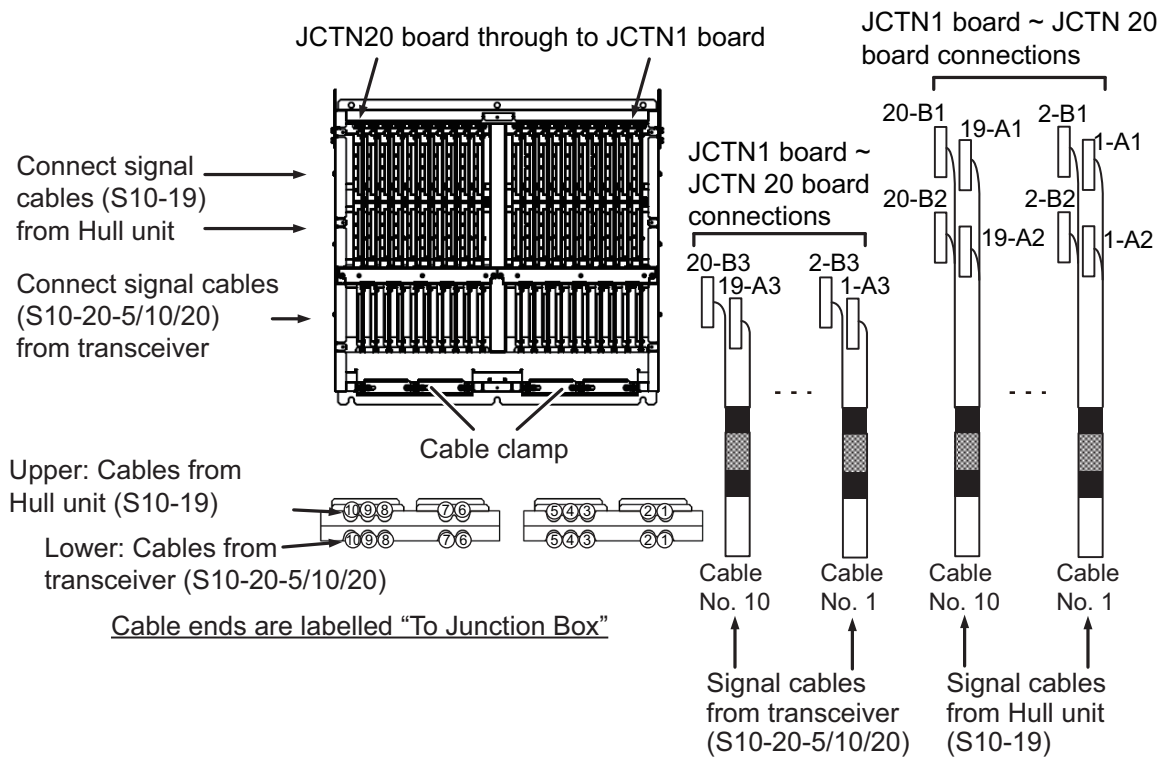

3. Pass the signal cables through the cable clamp, then secure them to the edge saddle and LWS clamp. The cables should be connected as shown in the diagram above, with the "To Junction Box" label side connecting to the junction box.
4. Place the shielded section of the cables in the cable clamp.
5. Secure the cables with the cable clamp.

Secure a ground plate (local supply) to the junction box's earth, then connect the junction box earth to the ship's earth.

2.7 Raise/Lower Control Box

Connect the 3 phase power cable and the transceiver unit cables (10CA10053 - marked with "Control Unit") as shown below.

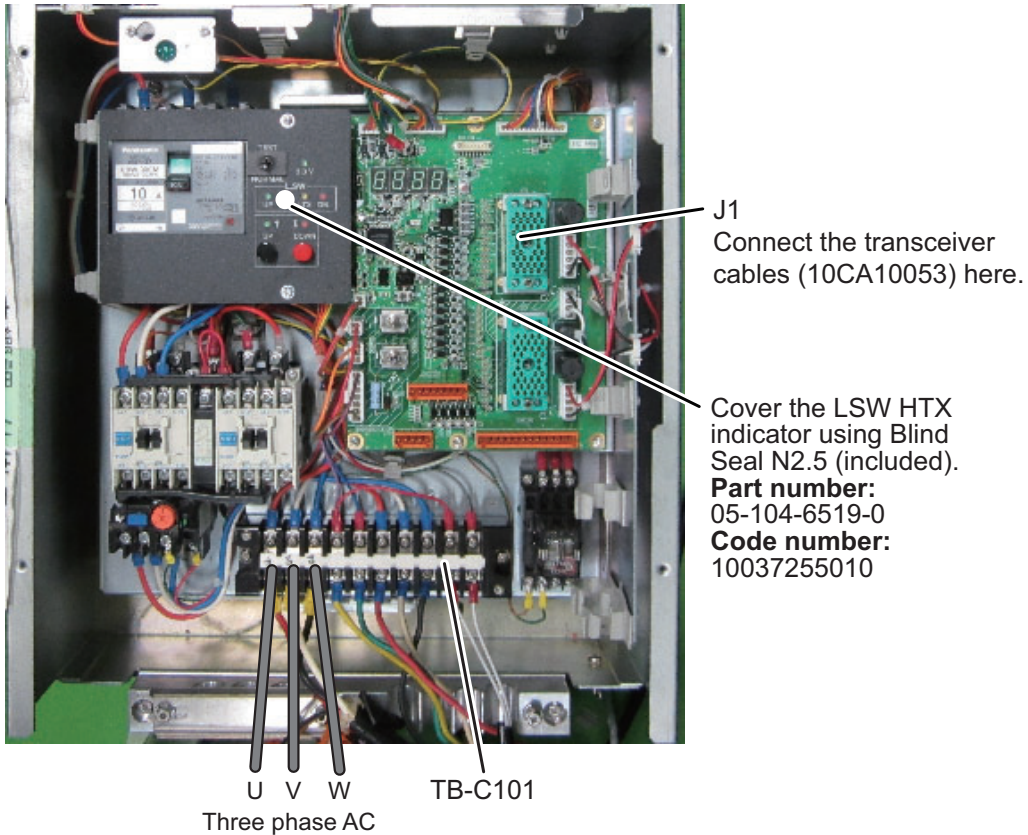

Confirm that the LED lights in red after the wiring is completed. If the LED does not light, turn off power from the mains switchboard, disconnect then reconnect the power cables, turn on the power, and check if the LED lights.

The hull unit does not work when the connection is wrong.

Normal phase: LED lights in red.

Phase reversal: LED does not light.

Fabricate the power cable as shown below.

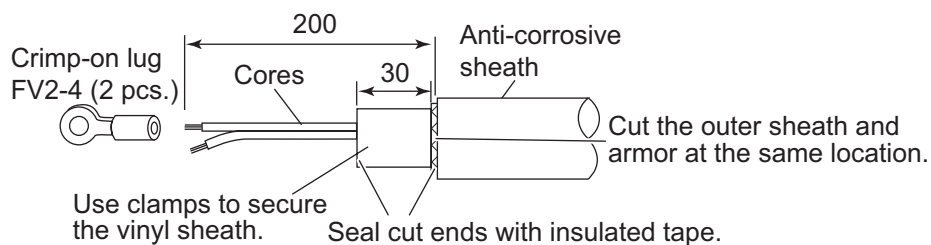

Ground connection

Use a ground wire (1V-8 sq., local supply) to connect to the ship's earth.

Secure the cables in the cable clamp as shown below.

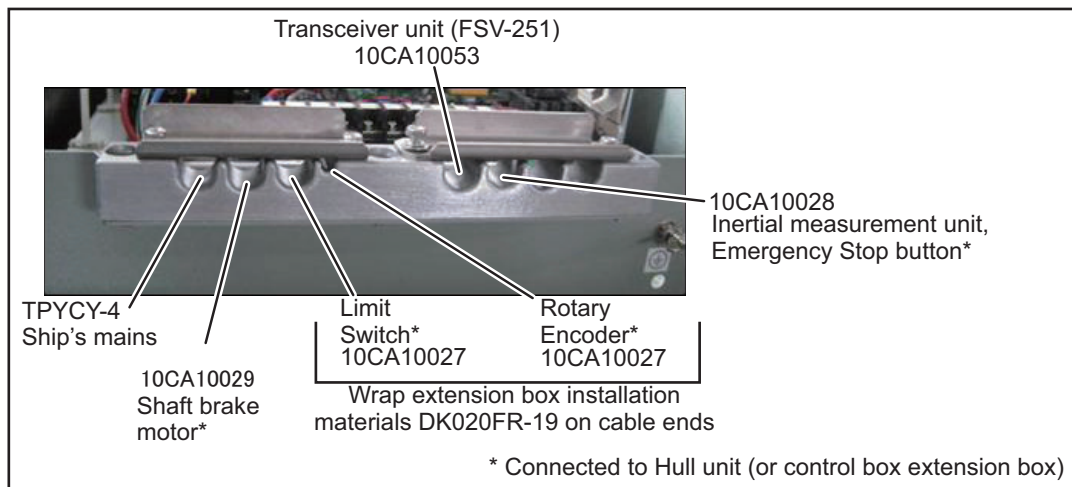

2.8 Power Supply Unit

Change the connector to the power supply according to the input voltage. Referring to the figure below, connect the power cable (DPYCY-2.5, supplied locally).

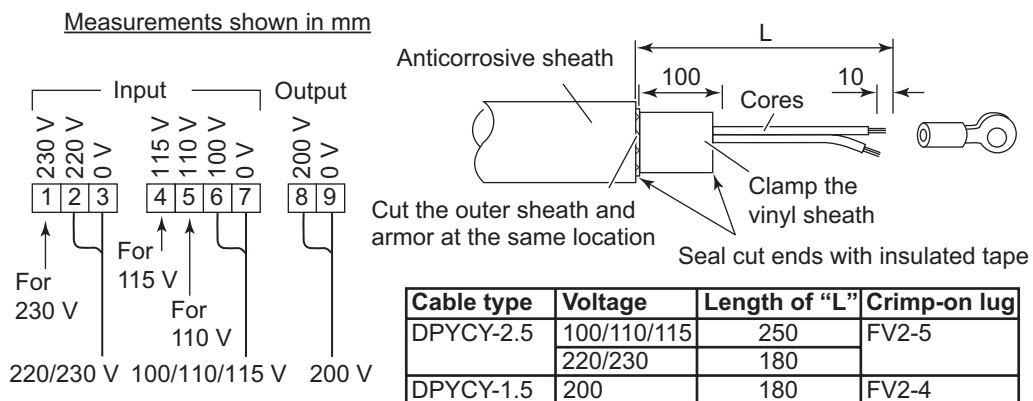

Breaker settings

The front panel of the power supply unit houses the breakers. Remove the protective sheet covering the lid, then open the panel to adjust the breaker settings.

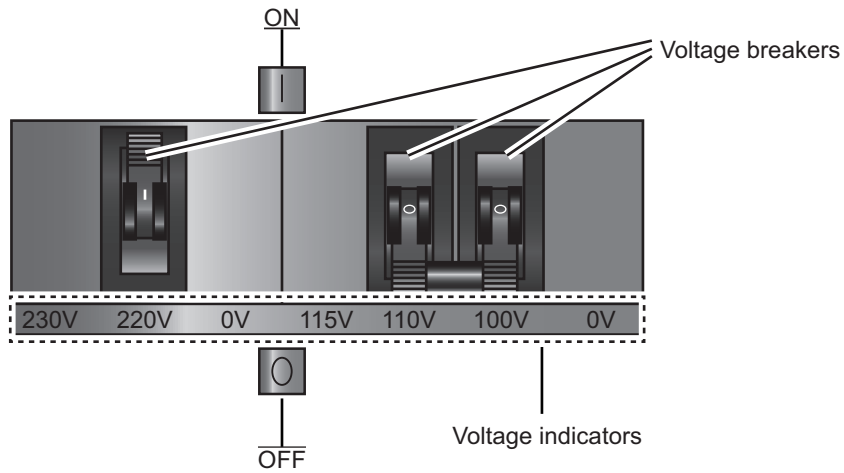

For 100/110/115V input set the double breaker on the right to ON.
For 220/230V input, set the single breaker on the left to ON.

⚠ WARNING

⚡ Only set one breaker to ON position at any time.

Setting both breakers to ON can result in high voltage in the unused terminal block.

Turn the unused breaker OFF always.

2.9 Control Box Extension Box

The raise/lower control box can be wall mounted up to 5 m away from the hull using the control box extension box.

1. Disconnect the raise/lower control box from the hull unit.
2. Connect the control box extension box to the hull unit, in the same place the raise/lower control box was originally connected.
3. Mount the raise/lower control box on a bulkhead within 5 m of the hull unit.
4. Connect the control box extension box to the raise/lower control box, using the included cables.

Note: When connecting the rotary encoder, limit switch and **EMERGENCY STOP** button to the control box extension box, disconnect the connectors from each cable and replace them with the included crimp-on lugs (See table below for details). Connect the connectors to the control box extension box cables.

See the Interconnection Diagrams at the back of this manual for information on how to wire the raise/lower control box and control box extension box.

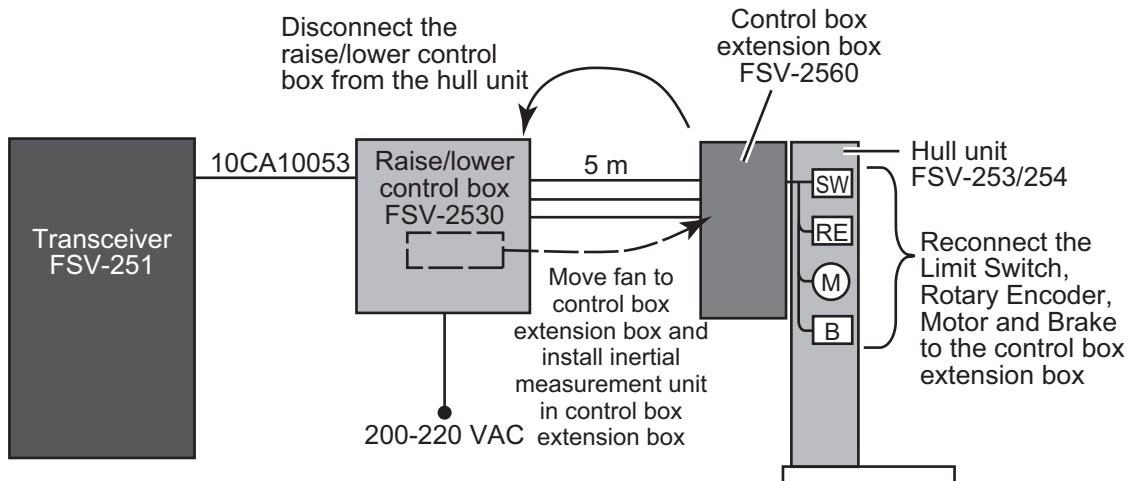

Crimp-on lug cable connections

Crimp-on lug	Cable
FV1.25-3	LMT_SW, Emergency stop button
FV0.5-3	Rotary encoder

2.9.1 Cable clamp location

Secure all connected cabling in the cable clamp, referring to the following figure.

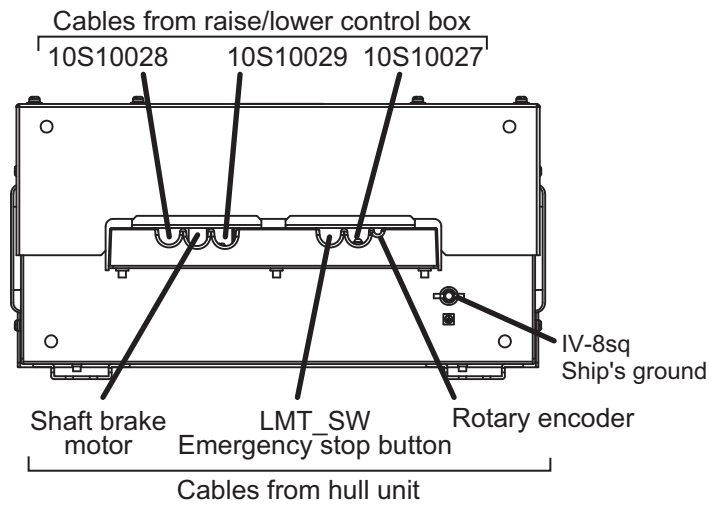

2.9.2 How to connect the fans and inertial measurement unit to the control box extension box

When using the control box extension box, the fans and inertial measurement unit from the raise/lower control box must be installed in the control box extension box. Follow the procedure below.

How to remove the fans and inertial measurement unit from the raise/lower control box

1. Unfasten six screws to remove the front cover.
2. Unfasten four screws to remove the top cover.

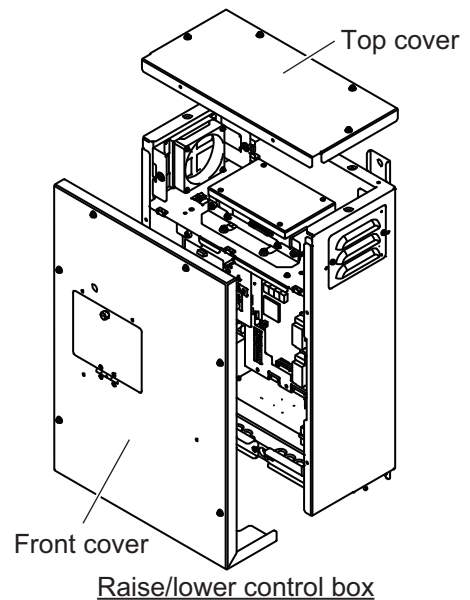

3. Disconnect the cable from the connector on the inertial measurement unit, then unfasten four screws to remove the unit.

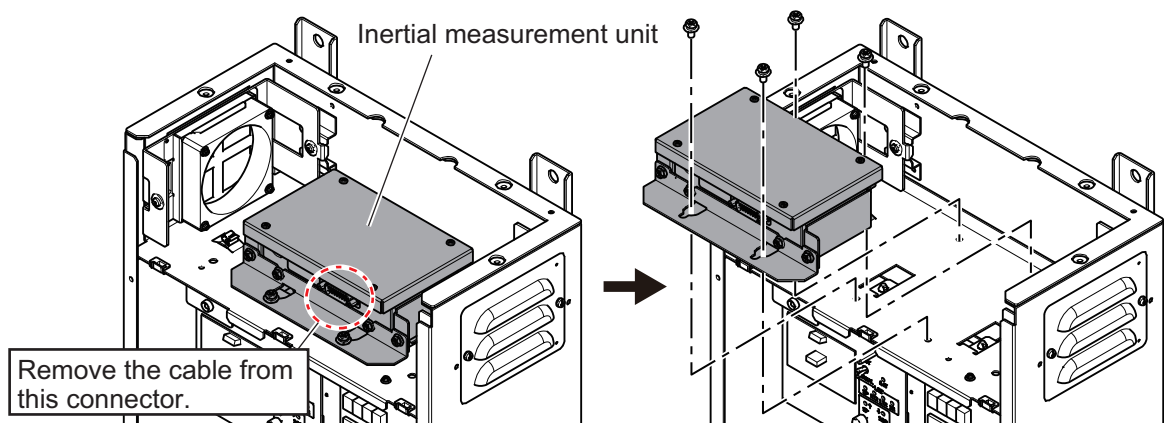

4. Disconnect the fan connectors, then unfasten screws to remove two fans.

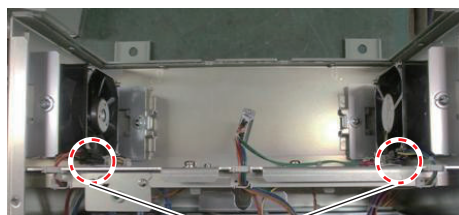

Remove these connectors.

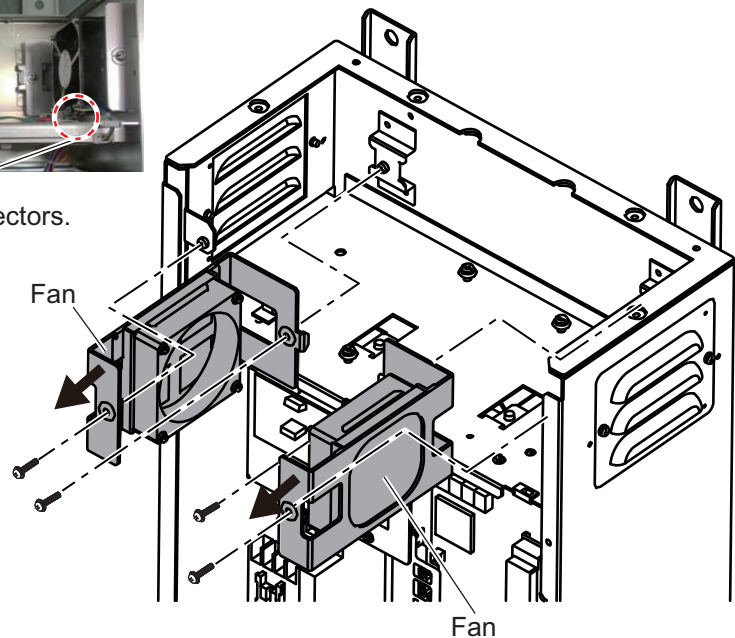

5. Reattach the top cover and front cover.

How to attach the fans and inertial measurement unit to the control box extension box

Note: The inertial measurement unit is extremely shock sensitive, take care not to drop it. Where possible, install the unit after the control box extension box has been installed.

2. WIRING

1. Unfasten six screws to remove the front cover.
2. Unfasten four screws to remove the top cover.

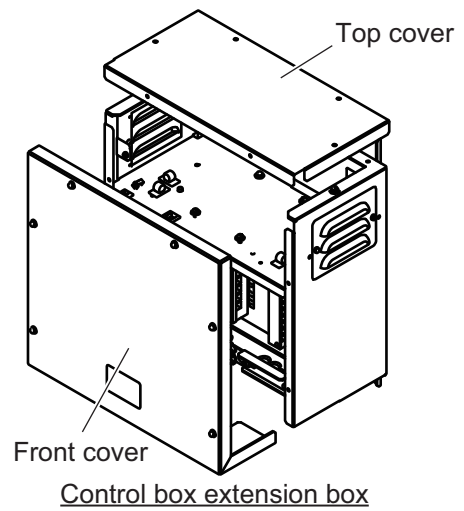

3. Install the fans in the control box extension box, using the four screws to secure them in place.

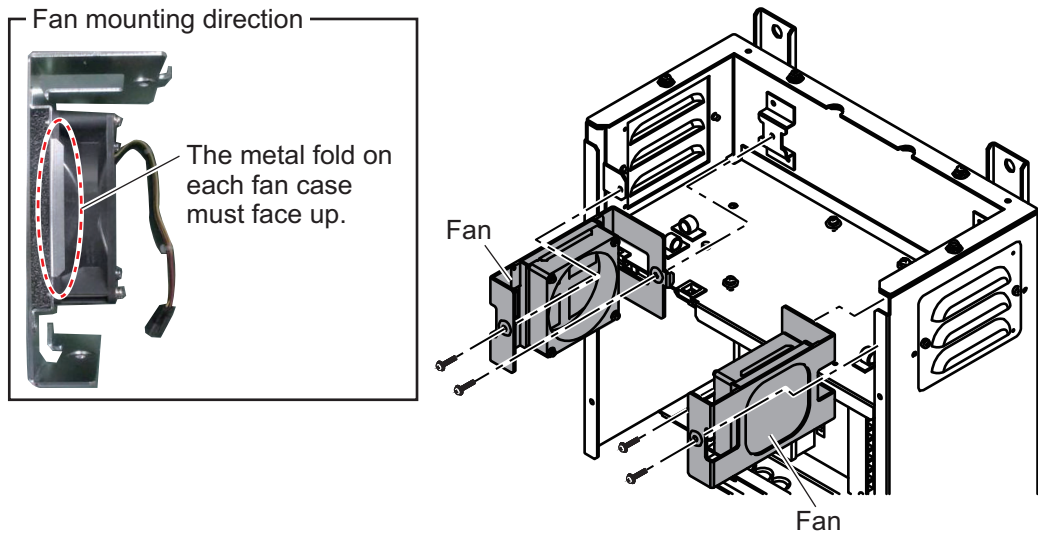

4. Connect the cables on the fan to the connector inside the control box extension box.

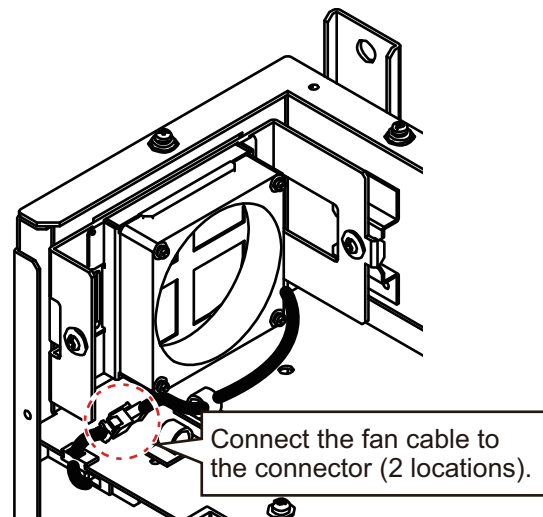

5. Unfasten four screws and set the inertial measurement unit, then fasten the screws to secure it.

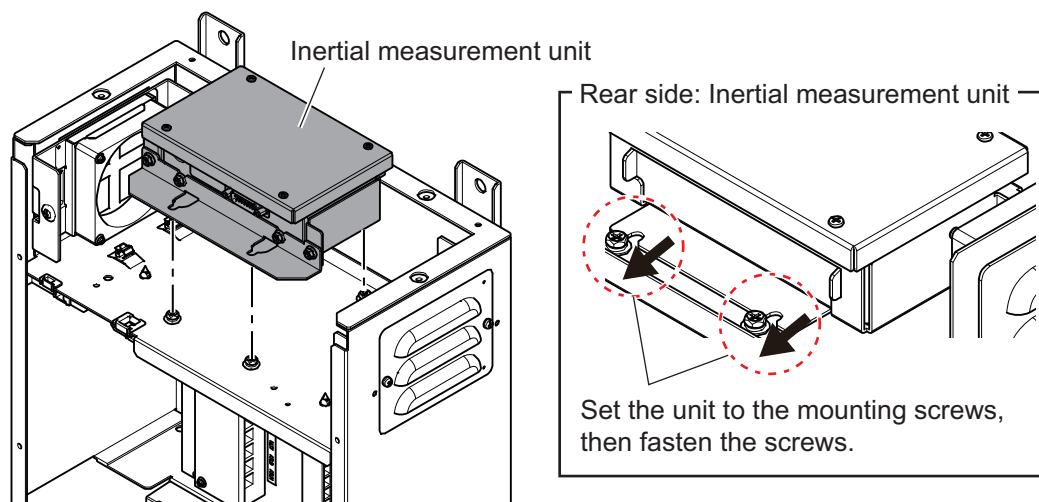

6. Connect the D-SUB connector inside the control box extension box to the inertial measurement unit.
7. Fasten the ground wire (crimp-on lug) of the D-SUB cable to the ground terminal.

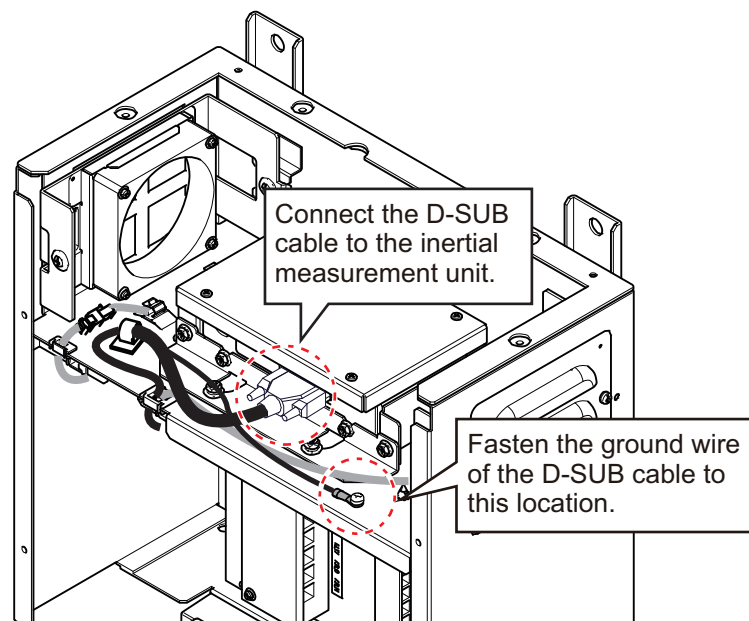

8. Reattach the top cover and front cover.

2. WIRING

This page is intentionally left blank.

3. POST INSTALLATION SETTINGS

3.1 How to Set the Language

This equipment is shipped with English set as the default language. To change the language in which the menus are displayed, follow the procedure below.

The following languages are supported:

English	Russian
Japanese	Chinese
French	Korean
Spanish	Turkish

Note: “Select” means move the cursor, using the trackball. Then, when highlighting a menu option, click the left button on the trackball to select the highlighted item.

1. Turn the power to the equipment on. After the startup procedure is complete, the menu is available.
2. Press the **MENU/ESC** key to open the menu. The main menu window will be displayed.

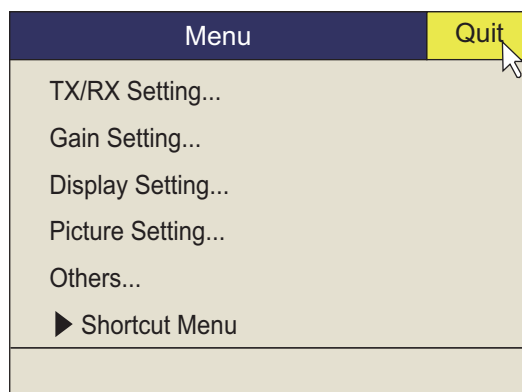

3. Select [Others] to display the [Others] menu.

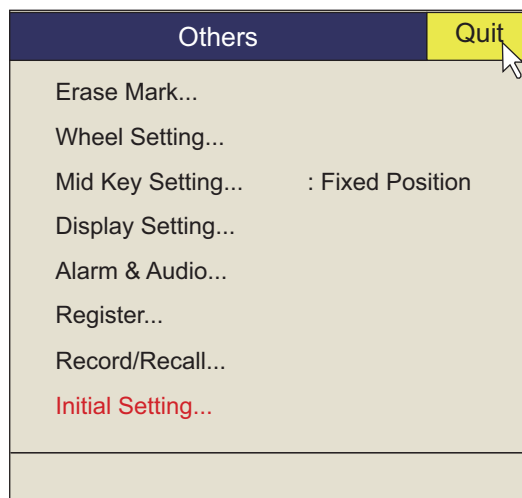

4. Select [Initial Setting] to display the [Initial Setting] menu.

3. POST INSTALLATION SETTINGS

5. Select [Changeable] then press the left button.

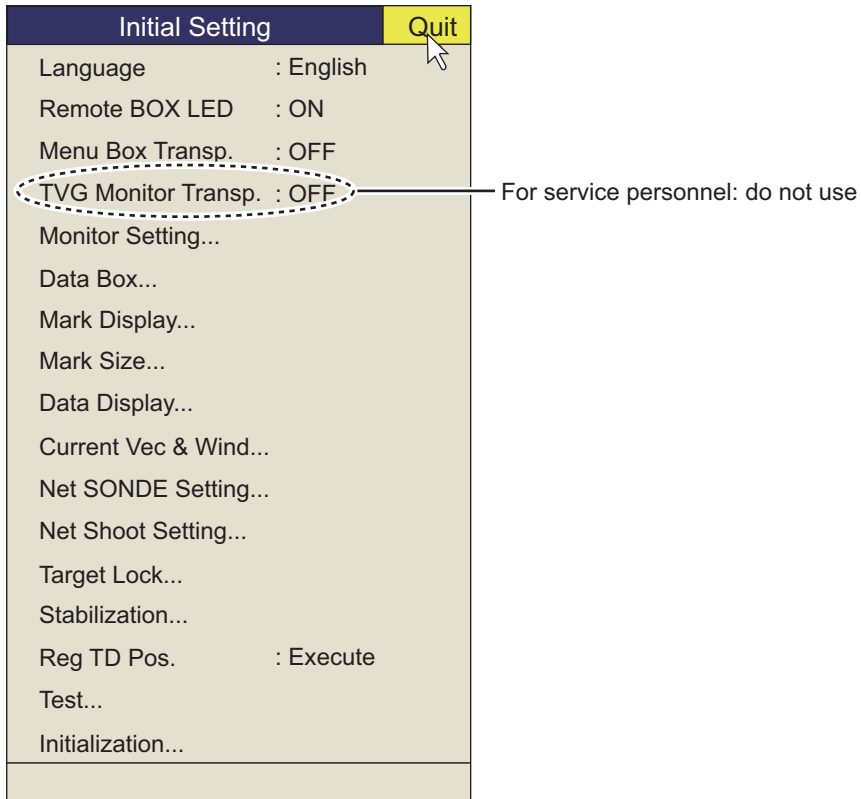



6. Select [Language] to display the available languages.
7. Select the appropriate language.
8. Select [Quit].
9. Press the **MENU/ESC** key to close the menu.

3.2 How to Set Up the Transducer

To display the distance which the transducer is protruded, the limit switch location must be entered at the processor unit.

To conduct this setting, the transducer must be at full protrusion. Also, confirm that the transducer is retracted before conducting this procedure.

Note: "Select" means move the cursor, using the trackball. Then, when highlighting a menu option, click the left button on the trackball to select the highlighted item.

1. Press the **MENU/ESC** key to open the menu. The main menu window will be displayed.
2. Select [Others] to display the [Others] menu.
3. Select [Initial Settings] to display the confirmation dialog pop-up window. Left click [Changeable] in the pop-up window to display the [Initial Settings] menu.
4. Select [Reg. TD Pos.]. The TD position registering window will be displayed with the message "TD position Registering 1/4".
5. Select [Next]. The TD position registering window will now display the message "TD position Registering 2/4".
The Mid-length protrusion length is calculated by subtracting 336 mm from the total retraction tank length. The default value for Mid-length protrusion is 876 mm. Therefore, if the retraction tank length is 1212 mm, the mid-length setting does not need adjusting.
6. Select [Next]. The TD position registering window will now display the message "TD position Registering 3/4".
7. Press the  key, then, when the transducer is at full protrusion, left click [Next]. The TD position registering window will now display the message "TD position Registering 4/4".
8. Select [Next] to complete the registration.
9. Press the  key to retract the transducer.
10. Select [Quit] to close the menu.

3.3 Hull Unit Checks

Note 1: To avoid damage to the equipment, do not transmit while dry docked.

Note 2: When performing maintenance to the hull unit and checking the movement, make sure that the power is on only to the hull unit and perform all checks in test mode to avoid accident or injury.

Note 3: Make sure all connections to the hull unit are made correctly, referring to the wiring table attached to the hull unit, to prevent the shaft from being dislodged.

How to check transmit status

Note: “Select” means move the cursor, using the trackball. Then, when highlighting a menu option, click the left button on the trackball to select the highlighted item.

Transmission is set to [OFF] as factory default. You can check and change the status by doing the following.

1. Press the **MENU/ESC** key to open the menu. The main menu window will be displayed.
2. Select [Others] to display the [Others] menu.
3. Select [Initial Setting] to display the [Initial Setting] menu.
4. Select [Changeable].
5. Select [Test] to display the [Test] menu.

Test		Quit
Operation Test...	: Execute	* For technician
Board Test...	: Execute	
Panel Test...	: Execute	
Test Pattern...	: Execute	
RX Test...*	: Execute	
FAN MONITOR	: Execute	
TX	: OFF	

Test menu

6. Select [TX].
7. Select [OFF] or [ON] as appropriate, then press the left button.
8. Select [Quit] to apply the settings.
9. Press the **MENU/ESC** key to close the menu.

How to check the hull unit

1. Turn the control unit ON. Check that the ON LED and  switch are on.

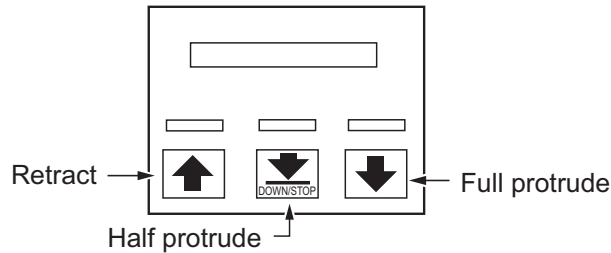

Protrude and retract switches on raise/lower control box

2. Check the top of the raise/lower control box to confirm the 3.3V and UP LEDs are on.
3. Remove the cover of the raise/lower control box and check the terminal voltage as shown in the table below.

Terminal block	Terminal No.	Voltage
TB-C101	(1) - (2)	220 VAC
	(2) - (3)	
	(1) - (3)	

4. In the raise/lower control box, set the **TEST/NORMAL** switch to [TEST]. Press the **DOWN** switch to confirm that the transducer lowers. Also, while the transducer is being lowered, check that the LTX LED lights when the **LTX** switch is passed by the transducer shaft bar.

Note: The **LTX** switch does not stop the transducer when the **TEST/NORMAL** switch is in the [TEST] position.

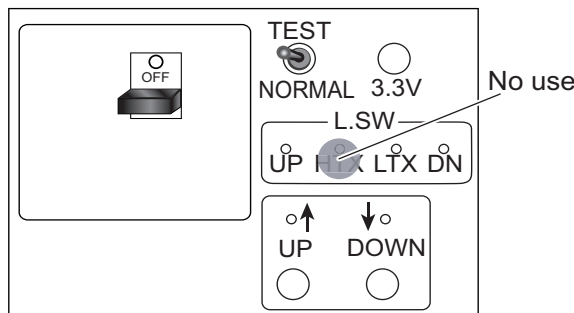

5. Release the **DOWN** switch during lowering to confirm that the transducer stops lowering.
6. Press the **DOWN** switch again to continue lowering. Confirm that the transducer stops at the moment when the **EMERGENCY STOP** switch is pressed. After you have confirmed the **EMERGENCY STOP** switch stops the hull unit lowering, release the **EMERGENCY STOP** switch by turning the switch clockwise.
7. Press the **DOWN** switch again to continue lowering. Confirm that the transducer stops at the moment when the lower limit switch is pressed.



EMERGENCY STOP button

During this process, via the side window on the raise/lower control box, check the LEDs inside the casing and that the following values are displayed.

Type	UP_LMT_SW ON	DN_LMT_SW ON
1600 travel	0	98 ~ 101
1200 travel	0	73 ~ 76



3. POST INSTALLATION SETTINGS

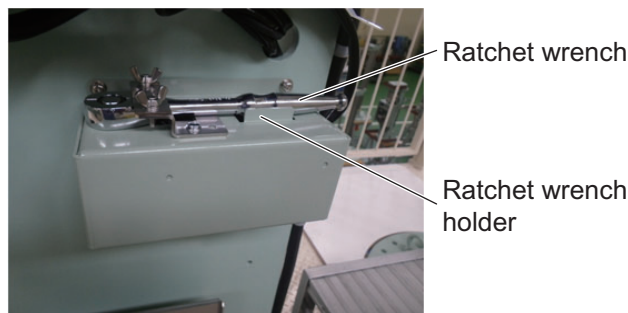

In cases where the LEDs do not display the above values, rectify the issue using the table on the following page for reference.

LED display	Possible cause	Remedy
Displayed values do not change.	Cabling not connected.	Connect cabling correctly.
Displayed values are negative.	Cabling is not connected correctly.	Re-connect cabling correctly.
Displayed value deviates from normal value.	LTX sensor switch position has moved.	Re-position the sensor switch.

8. Repeat the same tests while retracting the transducer.
9. Remove the ratchet wrench from its holder on the side of the hull unit. Press the **UP** switch, then the **DOWN** switch on the raise/lower control box to make sure the hull unit does not move. Once you have confirmed there is no movement in the hull unit, place the ratchet wrench back in its holder.



10. Check the following items in the raise/lower control box:
 - 1) Each of the LEDs, for UP, LTX and DN, light up when their respective limiter switch is pressed.
 - 2) The LEDs for [UP] and [DOWN] light up when their respective push-button switch is pressed.
11. When the above tests are complete, switch the [TEST/NORMAL] switch back to [NORMAL] on the raise/lower control box.
12. On the control unit, press the  switch and check that the hull unit is lowered to the half-way point. This must be done from a fully retracted position. While lowering, check to make sure the LED above the  switch is flashing, the limiter makes a short beep sound and once the shaft stops at half-protrude the LED lights constantly.

13. Adjust the LTX switch setting to allow clear transmission at half-protrusion by doing the following. If the retraction tank has been cut at 1212 mm, skip to step 14.
 - 1) Use the protrude/retract controls to adjust the transducer height until the transducer face is fully protruded.
 - 2) Adjust the location of the LTX switch so that the switch lever is the same height as the top of the transducer shaft bar.
14. Using the same method, check that the  switch and  switch LEDs flash and light constantly as appropriate and the limit switch beeps.
15. Turn the control unit power OFF and check that the transducer is retracted automatically. At full retraction, check that the power is OFF.
16. Check that the transducer is fully retracted using the  switch.

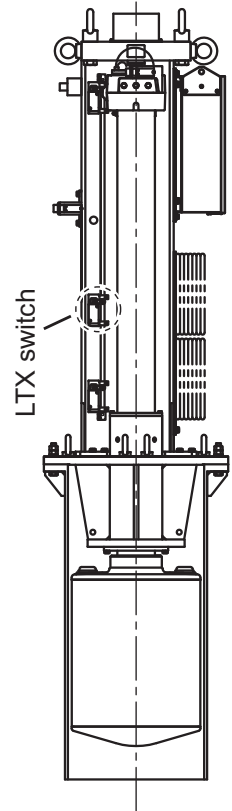

Brake test

Check that the brake is functioning correctly using the brake release switch and the procedure outlined below.

1. Set the toggle switch to MBRAKE (motor brake).
2. Make sure the brake LED is turned on.
3. Press the brake release switch and check that the shaft does not move. If the shaft moves, the brake which is not released may be malfunctioning. Consult your dealer for repairs. Also, if the shaft moves faster than the designated speed, the 7-segment LED shows [Err0].
4. Set the toggle switch to ABRAKE (drive shaft brake), then repeat steps 2 and 3.

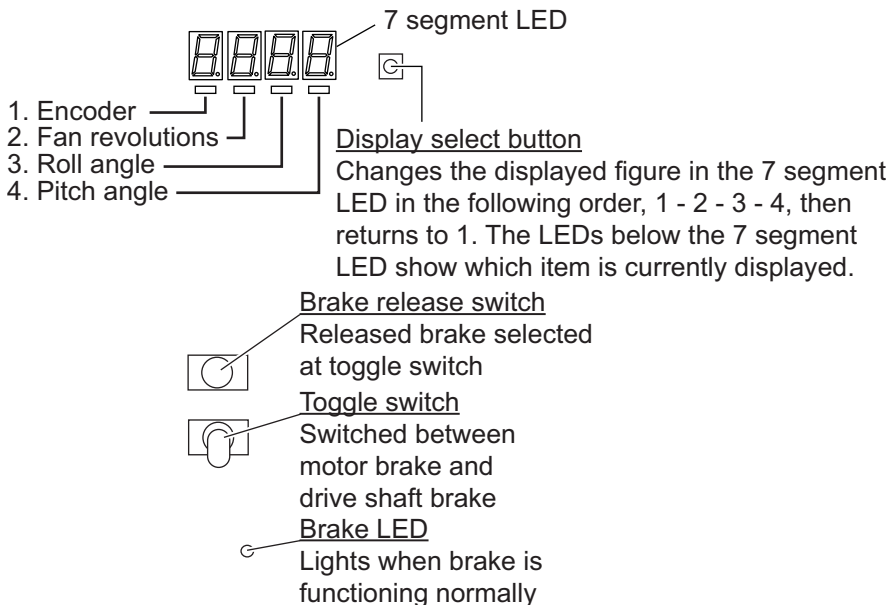

Fan motor and inertial measurement unit test

By changing the item displayed on the 7 segment LED, you can test the fan motor and inertial measurement unit. By pressing the display select button (shown in the figure above), you can change the displayed item. Use the following procedure to test the fan motor and inertial measurement unit.

1. Press the display select button to show the fan revolutions.
2. Confirm the fan revolutions are at 35 or higher. If they are lower than 35, there may be something wrong with the fan.
3. Press the display select switch to show the roll angle.
4. Rock the vessel and then check that the 7 segment LED displays a change.
5. Press the display select button to show the pitch angle.
6. Rock the inertial measurement unit and check that the 7 segment LED displays a change.
7. With the test completed, press the display select button to show the encoder revolutions.

3.4 How to Access the System Menu

The system menu is used by FURUNO technicians to set up and maintain the unit. This menu should not be accessed otherwise.

3.4.1 How to display the system menu

1. While pressing and holding down the **MENU/ESC** key, press **F1**, **F3**, **F5** in order.
2. Release the **MENU/ESC** key. The menu appears.
3. Close, then re-open the menu. Press the **MENU/ESC** key twice.
4. Select [Others] then left click.

The system menu is now displayed to the right side of the normal menu with the title "Others...".

3.5 How to Adjust the Heading

Heading correction at the hull unit

When the BOW mark on the flange of the hull unit can not be directed toward ship's bow perfectly, adjust the heading so an echo which is dead ahead appears dead ahead on the display.

1. Enable transmission as shown in "How to check transmit status" on page 3-4.
2. Find a target in the bow direction (buoy, for example) and display it on a near range. If the target appears at 12 o'clock, the heading alignment is correct. If it does not, measure the error and go to next step.

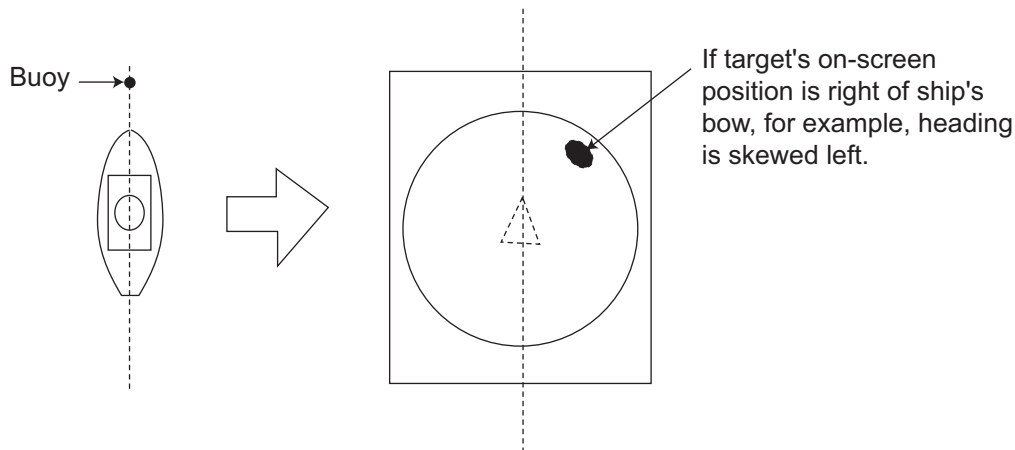

3. If the heading is skewed, measure the skew angle.
4. Access the system menu (See paragraph 3.4.1).
5. Select [Heading Adjust 1] then left click.
6. Rotate the scrollwheel to enter the angle measured at step 3. The setting range is -180° to 179° , in one-degree increments.
7. Select [Quit] then left click.
8. Long-press the **MENU/ESC** key to close all menus.

Heading correction at the inertial measurement unit

Heading correction at the inertial measurement unit is done with [Heading Adjust 2] on the [Others] menu.

- If the control box is mounted on the hull unit, set the same heading correction as entered for [Heading Adjust 1] (in [Others] menu).
- If the control box is mounted independent of the hull unit, set the angle measured from the bow in the clockwise direction. The angle is 0° if the lid of the control box is directed toward ship's stern precisely.
- If the inertial measurement unit is a GPS gyro, set the angle to 0° .

3.6 How to Configure the Own Ship Mark

Set your ship's length and width and the position of the transducer, to accurately display the own ship mark on the screen.

1. Access the system menu (See paragraph 3.4.1).
2. Select [Own Ship Mark] then left click.
3. Select [Ship's Length] then left click.
4. Use ▲ or ▼ to set length. The setting range is 15 to 150 m.
5. Set the [Ship's Width] and [TD Position 1 (or 2)] similarly.

- **[Ship's Width]:** The width of the ship at its widest point. (Setting range 5 to 30 m)
- **[TD Position 1]:** Distance from transducer to bow. (Setting range: 5 to 50 m)
- **[TD Position 2]:** Distance from transducer to keel. Select [+] for starboard, [-] for port. (Setting range: -10 to 10 m)

6. Select [Quit] to apply the settings.
7. Long-press the **MENU/ESC** key to close all menus.

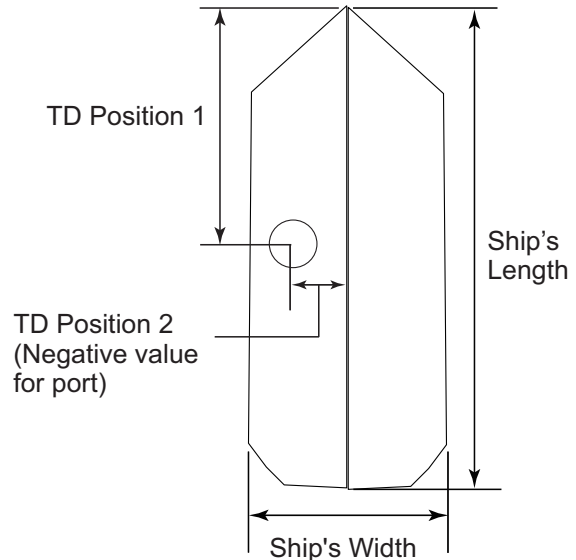

3.7 How to Set Up a Secondary Monitor

When a secondary monitor is connected, use the following procedure to adjust the display settings.

1. Access the system menu (See paragraph 3.4.1).
2. Select [Initial Settings], then left click.
3. Select [Monitor Settings], then left click.
4. Select [2nd Monitor Display], then left click.
5. Select [Dual Display] or [Sub Display] as appropriate, then left click.
 - [Dual Display]:** When in Dual mode, each display can be assigned as Main or Sub monitor.
 - [Sub Display]:** Displays the same screen as the Main or Sub monitor. When there is no secondary monitor connected, set this option to [OFF].
6. Select [Quit] at the top-right of the Menu box, then left click.
7. Restart the unit (turn power OFF then ON) to apply the settings.

3.8 Other System Menu Items

This section gives a brief explanation of menu items not previously described.

3.8.1 Interface Setting menu

- **[NMEA1/2/3 Baud Rate]:** Set the transmission rate for the NMEA 1, NMEA 2 and NMEA 3 ports. (4800 bps, 9600 bps, 19200 bps, 38400 bps.)
Priority order:NMEA1>NMEA2>NMEA3.
- **[CIF1/2 Baud Rate]:** Set the transmission rate for the CIF 1 and CIF 2 ports. (2400 bps, 4800 bps, 9600 bps, 19200 bps). Priority order: CIF1>CIF2.
- **[EXT KP Input]:** Set the input logic of KP from external equipment.
(Disable, Enable) **Disable:** Disable external KP. **Enable:** Use KP from external equipment.

3.8.2 EXT Data Setting menu

- **[Date&Time]:** Select the input format for date and time data. (NONE, CIF, NMEA)
- **[Heading]:** Select the input format for heading data. (NONE, AD10, CIF, NMEA)
- **[Speed&Course]:** Select the input format for ship's speed and course data.
(NONE, CIF, NMEA)
- **[Speed Sensor]:** Select the input format for speed data.
(NONE, GPS/DR, DOPPLER/DR) If response is slow, select GPS/DR.
- **[Lat/Lon]:** Select the input format for position data. (NONE, CIF, NMEA)
- **[POS Sensor]:** Select the type of the navigator used. Select [Auto Sel] when more than one navigator is connected.
The priority for auto selection is GPS/DR> Loran-C. (Loran C, GPS/DR, Auto Sel)
- **[Water Depth]:** Select the input format for water depth. (NONE, CIF, NMEA)
- **[Water Temp]:** Select the input format for water temperature. (NONE, CIF, NMEA)
- **[Water Current]:** Select the input format for water current. (NONE, CIF, NMEA)
- **[Wind]:** Select the input format for wind data. (NONE, CIF, NMEA)
- **[Net Depth]:** Select the input format for net depth data. (NONE, CIF)
- **[CIF Type]:** Select the CIF type to use. (CIF-2000, CS-120A)

3.8.3 Others menu

- **[Trackball Speed]:** Select the tracking speed (in menu windows only) for the trackball. (Slow, Normal, Fast)
- **[Hull Unit Stroke]:** Select the travel of the hull unit. (1200 mm, 1600 mm)
- **[Error Code List]:** Displays a list of error codes for easy error identification.
- **[Explorer]:** Check and search files.
- **[NMEA/CIF Monitor]:** Accessed via system menu (See paragraph 3.4.1) → [Others...] menu → [Test & Initialization] menu → [NMEA/CIF Monitor] menu. The NMEA/CIF Monitor functions as a test tool for NMEA/CIF sentence input and output.
- **[Channel Test 3]:** Accessed via system menu (See paragraph 3.4.1) → [Others...] menu → [Test & Initialization] menu → [Channel Test 3]. Tests the connection between the transducer and the junction box for faults. After installation is completed, conduct this test to ensure the connection is correct. Faults in connection or wiring are displayed in black.
- **[Monitor Sel.]:** For technicians only. Selects monitor to display signal data.
- **[Data Display]:** Turn Date and Time display on or off.
- **[Setting Disp.]:** Displays current fishing settings on the left-hand side and right-hand side of the screen as abbreviations.
- **[T_parameter]:** For technicians only. Contains evaluative functions.

APPENDIX 1 JIS CABLE GUIDE

Cables listed in the manual are usually shown as Japanese Industrial Standard (JIS). Use the following guide to locate an equivalent cable locally.

JIS cable names may have up to 6 alphabetical characters, followed by a dash and a numerical value (example: DPYC-2.5).

For core types D and T, the numerical designation indicates the *cross-sectional Area (mm²)* of the core wire(s) in the cable.

For core types M and TT, the numerical designation indicates the *number of core wires* in the cable.

1. Core Type

D: Double core power line
 T: Triple core power line
 M: Multi core
 TT: Twisted pair communications
 (1Q=quad cable)

2. Insulation Type

P: Ethylene Propylene
 Rubber

3. Sheath Type

Y: PVC (Vinyl)

4. Armor Type

C: Steel

5. Sheath Type

Y: Anticorrosive vinyl
 sheath

6. Shielding Type

S: All cores in one sheath
 -S: Individually sheathed cores
 SLA: All cores in one shield, plastic
 tape w/aluminum tape
 -SLA: Individually shielded cores,
 plastic tape w/aluminum tape



DPYCY



TPYCY

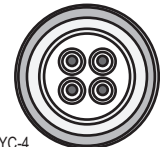

MPYC-4

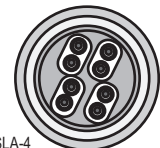

TTYCSLA-4

EX: ^{1 3 4 5 6} TTYCYSLA - 4
 Designation type # of twisted pairs

EX: ^{1 2 3 4} MPYC - 4
 Designation type # of cores

The following reference table lists gives the measurements of JIS cables commonly used with Furuno products:

Type	Core		Cable Diameter	Type	Core		Cable Diameter
	Area	Diameter			Area	Diameter	
DPYC-1.5	1.5mm ²	1.56mm	11.7mm	TTYCS-1	0.75mm ²	1.11mm	10.1mm
DPYC-2.5	2.5mm ²	2.01mm	12.8mm	TTYCS-1T	0.75mm ²	1.11mm	10.6mm
DPYC-4	4.0mm ²	2.55mm	13.9mm	TTYCS-1Q	0.75mm ²	1.11mm	11.3mm
DPYC-6	6.0mm ²	3.12mm	15.2mm	TTYCS-4	0.75mm ²	1.11mm	16.3mm
DPYC-10	10.0mm ²	4.05mm	17.1mm	TTYCSLA-1	0.75mm ²	1.11mm	9.4mm
DPYCY-1.5	1.5mm ²	1.56mm	13.7mm	TTYCSLA-1T	0.75mm ²	1.11mm	10.1mm
DPYCY-2.5	2.5mm ²	2.01mm	14.8mm	TTYCSLA-1Q	0.75mm ²	1.11mm	10.8mm
DPYCY-4	4.0mm ²	2.55mm	15.9mm	TTYCSLA-4	0.75mm ²	1.11mm	15.7mm
MPYC-2	1.0mm ²	1.29mm	10.0mm	TTYCY-1	0.75mm ²	1.11mm	11.0mm
MPYC-4	1.0mm ²	1.29mm	11.2mm	TTYCY-1T	0.75mm ²	1.11mm	11.7mm
MPYC-7	1.0mm ²	1.29mm	13.2mm	TTYCY-1Q	0.75mm ²	1.11mm	12.6mm
MPYC-12	1.0mm ²	1.29mm	16.8mm	TTYCY-4	0.75mm ²	1.11mm	17.7mm
TPYC-1.5	1.5mm ²	1.56mm	12.5mm	TTYCY-4S	0.75mm ²	1.11mm	21.1mm
TPYC-2.5	2.5mm ²	2.01mm	13.5mm	TTYCY-4SLA	0.75mm ²	1.11mm	19.5mm
TPYC-4	4.0mm ²	2.55mm	14.7mm	TTYCYS-1	0.75mm ²	1.11mm	12.1mm
TPYCY-1.5	1.5mm ²	1.56mm	14.5mm	TTYCYS-4	0.75mm ²	1.11mm	18.5mm
TPYCY-2.5	2.5mm ²	2.01mm	15.5mm	TTYCYSLA-1	0.75mm ²	1.11mm	11.2mm
TPYCY-4	4.0mm ²	2.55mm	16.9mm	TTYCYSLA-4	0.75mm ²	1.11mm	17.9mm

APPENDIX 2 FRP TANK INSTALLATION

Keep the following points in mind when installing the FSV-25 inside a FRP tank.

- FURUNO does not supply any type of FRP tank.
Keep in mind the structural integrity and waterproofing of the vessel when fabricating a FRP tank. FURUNO takes no responsibility for the fabrication or design of the FRP.
- The FRP tank flange must be as smooth as possible. Peaks and troughs should be 0.5 mm or less.
- The term “liquid gasket” refers to the sealant recommended by the fabricator.
- Use a Joint Sheet equivalent to “Tombo No. 1995 CLINSIL - Brown” as the waterproofing gasket.

Waterproofing gasket dimensions

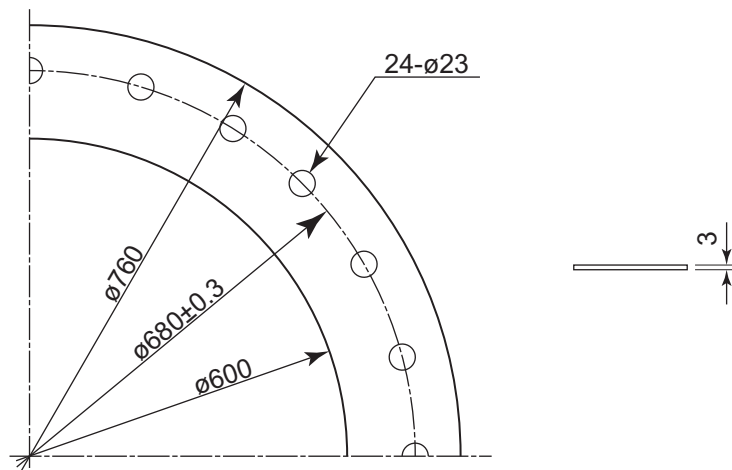

Prepare the following items:

- Spanner - M20 with opposite side of 30 mm.
- Ethyl alcohol - 99.5%.
- Waste cloths - Appropriate amount.
- Lithium grease - Daphne Grease MP No.2 (IDEMITSU KOSAN CO.,LTD) or equivalent.
- Liquid gasket - ThreeBond TB1184 or equivalent.

Installation

1. Clean the retraction tank flange using a cloth and ethyl alcohol. Allow the area to dry before moving to the next step.
2. Apply a coat of liquid gasket to the retraction tank flange. Apply extra liquid gasket to the inner edge of the flange, to prevent water leakage. (See figure to the right.)
3. Place the waterproofing gasket on the liquid gasket, then apply an even coat of liquid gasket over the waterproofing gasket.
4. Clean the hull unit flange, taking care not to drop anything on the retraction tank flange.

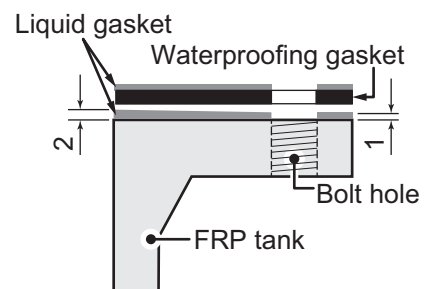

5. Insert the hull unit into the retraction tank and orient the hull unit so that the bow mark (inscribed on the hull unit flange) points toward the ship's bow.
Also, take note of the waterproofing gasket bolts holes and the flange bolt holes. Make sure all three bolt holes align.
Note: Heading adjustment is required if the bow mark is not facing the ship's bow. (See "How to Adjust the Heading" on page 3-9.)
6. Apply a slight amount of lithium grease to the threads of the stud bolt on the hull unit, to prevent scorching.
7. Put a flat washer, spring washer and two hex nuts (in that order) on the stud bolt. Fasten the two hex nuts by hand.
8. Insert the bolts with washers from the retraction tank flange, and then put one flat washer, one spring washer and one hex nut on each bolt. Fasten the hex nuts by hand. Leave one bolt hole empty (you should have one bolt, one spring washer, two flat washers and one hex nut remaining).
9. Fasten the hex nuts at all locations (except the empty bolt hole), to secure the flanges in place. Insert the final bolt, using the same order for washers and the nut as described in step 8, then fasten the hex nuts on the final bolt.
10. Check that all bolts are firmly fastened, that the flanges are connected evenly and that no "biting" of the waterproofing gasket has occurred. Re-fasten as required.

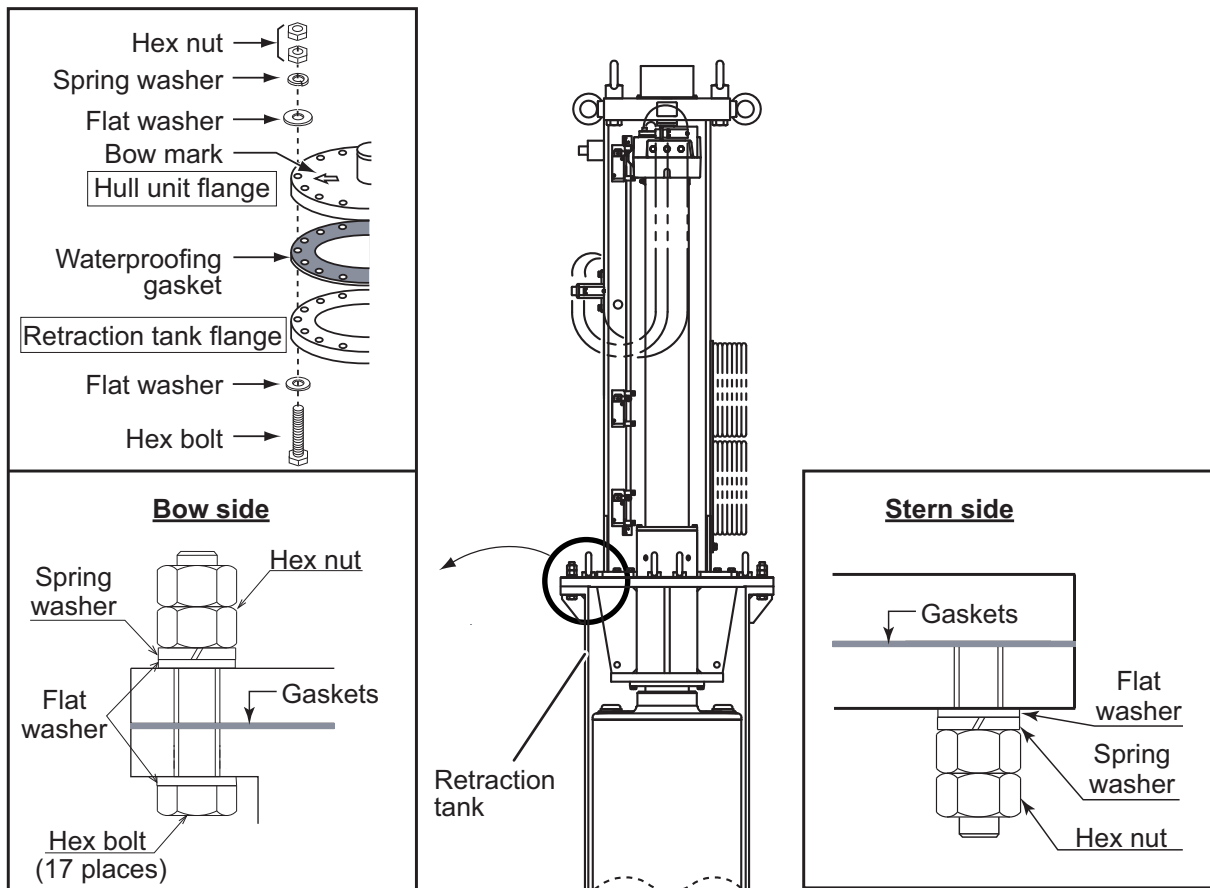





Fastening torque for all flange hex nuts: 230 N•m

PACKING LIST

10CX-X-9852 -5 1/1

FSV-8502

A-1

NAME	UNIT	OUTLINE	DESCRIPTION/CODE No.	Q'TY
ユニット	UNIT			
IFユニット			FSV-8502	1
INTERFACE UNIT		299 380	000-017-122-00	
工事材料	INSTALLATION MATERIALS		CP10-07300	
ケーブル(フレッツ)LAN			10CAZ383 *3M*	1
CABLE ASSEMBLY (LAN)		L=3M	000-174-158-13	
ケーブル組品M			IMJ-A3SPF0026-030C	1
POWER CABLE ASSEMBLY		L=3M	000-174-486-11	
工事材料	INSTALLATION MATERIALS		CP10-07301	1
INSTALLATION MATERIALS			001-112-510-00	

(略図の寸法は、参考値です。 DIMENSIONS IN DRAWING FOR REFERENCE ONLY.)



C1335-202-F

PACKING LIST

10CX-X-9851 -0 1/1

FSV-2501-J-5, FSV-2501-J-10, FSV-2501-E-5, FSV-2501-E-10

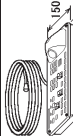
A-2

NAME	UNIT	OUTLINE	DESCRIPTION/CODE No.	Q'TY
ユニット	UNIT			
操作部			FSV-2501-**	1
CONTROL UNIT		380 150	000-025-012-00 **	
工事材料	INSTALLATION MATERIALS			
KB取付金具			CP03-33202	1
KB FIXTURE ASSEMBLY			001-119-510-00	
工事材料			CP10-07201	1
INSTALLATION MATERIALS			001-112-500-00	

コード番号末尾の[**]は、選択品の代表コードを表します。
CODE NUMBER ENDING WITH "**" INDICATES THE CODE NUMBER OF REPRESENTATIVE MATERIAL

型式/コード番号が2段の場合、下段より上段に代わる過渡期品であり、どちらかが入っています。なお、品質は変わりません。
TWO TYPES AND CODES MAY BE LISTED FOR AN ITEM. THE LOWER PRODUCT MAY BE SHIPPED IN PLACE OF THE UPPER PRODUCT. QUALITY IS THE SAME.

(略図の寸法は、参考値です。 DIMENSIONS IN DRAWING FOR REFERENCE ONLY.)

C1344-201-A

PACKING LIST
FSV-2503, FSV-2503S

10CX-X-9852 -0 1/1

A-3

NAME	OUTLINE	DESCRIPTION/CODE No.	QTY
ユニット			
制御部 PROCESSOR UNIT		FSV-2503* 000-025-022-00 **	1
予備品			
予備品 SPARE PARTS		SP19-00501 001-023-090-00	1
工事材料			
ケーブル組品 CABLE ASSEMBLY		FRDD-18AFFM-L180 000-164-608-10	1
工事材料 INSTALLATION MATERIALS		CP19-00601 001-023-100-00	1
図書			
ユーザー変更のお願い NOTIFICATION DOCUMENT		C42-00705-* 000-167-240-1*	1

コード番号末尾の[**]は、選用品の代表コードを表します。
CODE NUMBER ENDING WITH "**" INDICATES THE CODE NUMBER OF REPRESENTATIVE MATERIAL

型式/コード番号が各段の場合、下段より上段に代わる過渡期品であり、どちらかが入っています。なお、品質は変わりません。
TWO TYPES AND CODES MAY BE LISTED FOR AN ITEM. THE LOWER PRODUCT MAY BE SHIPPED IN PLACE OF THE UPPER PRODUCT. QUALITY IS THE SAME.

(略図の寸法は、参考値です。 DIMENSIONS IN DRAWING FOR REFERENCE ONLY.)

C1344-Z02-A

PACKING LIST
FSV-251-J, FSV-251-E, FSV-251S-E

10CX-X-9853 -2 1/1

A-4

NAME	OUTLINE	DESCRIPTION/CODE No.	QTY
ユニット			
送受信装置 TRANSCIEVER UNIT		FSV-251* 000-025-030-00 **	1
予備品			
予備品 SPARE PARTS		SP10-03901 001-268-990-00	1
工事材料			
ワイヤロープ 防振器 WIRE ROPE ANTI-VIBRATION		CP10-09302 001-349-800-00	2
工事材料 INSTALLATION MATERIALS		CP10-09301 001-349-780-00	1
防振カバー VIBRATION ISOLATION COVER		CP10-09303 001-349-820-00	2
図書			
取扱説明書 OPERATOR'S MANUAL		OM*-13440-* 000-178-767-1*	1
整備要領書(和) INSTALLATION MANUAL (JP)		IMJ-13440-* 000-178-771-1*	1 (*1)
整備要領書(英) INSTALLATION MANUAL (EN)		IME-13440-* 000-178-773-1*	1 (*2)

コード番号末尾の[**]は、選用品の代表コードを表します。
CODE NUMBER ENDING WITH "**" INDICATES THE CODE NUMBER OF REPRESENTATIVE MATERIAL

2(*1)の書類は和文仕様専用です。

(*1): FOR JAPANESE SET.

3(*2)の書類は英文仕様専用です。

(*2): FOR ENGLISH SET.

型式/コード番号が各段の場合、下段より上段に代わる過渡期品であり、どちらかが入っています。なお、品質は変わりません。
TWO TYPES AND CODES MAY BE LISTED FOR AN ITEM. THE LOWER PRODUCT MAY BE SHIPPED IN PLACE OF THE UPPER PRODUCT. QUALITY IS THE SAME.

(略図の寸法は、参考値です。 DIMENSIONS IN DRAWING FOR REFERENCE ONLY.)

C1344-Z03-C

PACKING LIST
FSV-252

10CX-X-9856 -1 1/1

A-5

NAME	OUTLINE	DESCRIPTION/CODE No.	Q'TY
ユニット			
電源装置 POWER UNIT		FSV-252 000-025-239-00	1
工事材料			
7-ス板			
COPPER STRAP		WEA-1004-0 ROHS 500-310-040-10	1
圧着端子 CRIMP-ON LUG		FV2-4 BLU K 000-157-247-11	2
圧着端子 CRIMP-ON LUG		FV2-5 BLU K 000-157-248-11	2
図書			
電源設定書 POWER SETTING INSTRUCTIONS		C12-01304-* 000-178-996-1*	1

(略図の寸法は、参考値です。 DIMENSIONS IN DRAWING FOR REFERENCE ONLY.)

C1344-Z04-B

PACKING LIST
FSV-2550

10CX-X-9857 -0 1/1

A-6

NAME	OUTLINE	DESCRIPTION/CODE No.	Q'TY
ユニット			
接続箱 JUNCTION BOX		FSV-2550 000-025-019-00	1
工事材料			
工事材料			
INSTALLATION MATERIALS		CP10-07801 001-268-610-00	1
接続箱取付板 FIXING PLATE OF JUNCTIONBOX		10-089-5583-0 100-387-080-10	1

型式/コード番号が2段の場合、下段より上段に代わる過渡期品であり、どちらかが入っています。なお、品質は変わりません。
TWO TYPES AND CODES MAY BE LISTED FOR AN ITEM. THE LOWER PRODUCT MAY BE SHIPPED IN PLACE OF THE UPPER PRODUCT. QUALITY IS THE SAME.
(略図の寸法は、参考値です。 DIMENSIONS IN DRAWING FOR REFERENCE ONLY.)

C1344-Z05-A



PACKING LIST

FSV-853

100Y-X-9856 -0

1/1

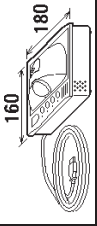
A-7

NAME	UNIT	OUTLINE	DESCRIPTION/CODE No.	Q'TY
ユニット 簡易操作部 CONTROL UNIT			FSV-853 000-019-213-00	1
工事材料 INSTALLATION MATERIALS				
工事材料 INSTALLATION MATERIALS			GP10-07501 001-135-210-00	1

型式/コード番号が2段の場合、下段より上段に代わる過渡期品であり、どちらが入っています。なお、品質は変わりません。
TWO TYPES AND CODES MAY BE LISTED FOR AN ITEM. THE LOWER PRODUCT MAY BE SHIPPED IN PLACE OF THE UPPER PRODUCT. QUALITY IS THE SAME.

(略図の寸法は、参考値です。DIMENSIONS IN DRAWING FOR REFERENCE ONLY.)

C1335-Z06-A



PACKING LIST

FSV-253-T

100Y-X-9860 -1

1/1

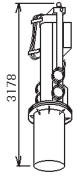

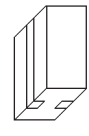
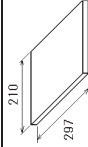
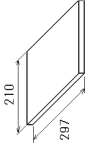
A-8

NAME	UNIT	OUTLINE	DESCRIPTION/CODE No.	Q'TY
ユニット 上下装置 HULL UNIT			FSV-253-T 000-025-049-00	1
予備品 SPARE PARTS				
予備品 SPARE PARTS			SP10-04201 001-269-280-00	1
工事材料 INSTALLATION MATERIALS				
工事材料箱詰 INSTALLATION MATERIALS (IN BOX)			CP10-08300 000-025-069-00	1
図書 DOCUMENT				
装備要領書 (英) INSTALLATION MANUAL (EN)			IME-13440-* 000-178-773-1*	1
装備要領書 (和) INSTALLATION MANUAL (JP)			IMJ-13440-* 000-178-771-1*	1

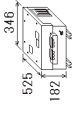

(略図の寸法は、参考値です。DIMENSIONS IN DRAWING FOR REFERENCE ONLY.)

C1344-Z06-B

PACKING LIST
FSV-2530-25-B2 10CX-X-9882 -2 1/1
A-10

NAME	OUTLINE	DESCRIPTION/CODE No.	Q'TY
ユニット			
制御器		FSV-2530	1
RAISE/LOWER CONTROL BOX			
予備品			
予備品		001-596-900-00	
SPARE PARTS			
予備品		SP10-04201	1
SPARE PARTS			
工事材料			
INSTALLATION MATERIALS			
工事材料		CP10-08101	1
INSTALLATION MATERIALS			
図書			
装備要領書(和)		IMJ-13440-*	1
INSTALLATION MANUAL (JP)			
		000-178-771-1*	

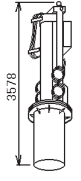
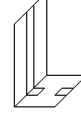
PACKING LIST
FSV-254-T 10CX-X-9862 -1 1/1
A-9

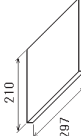
NAME	OUTLINE	DESCRIPTION/CODE No.	Q'TY
ユニット			
上下装置		FSV-254-T	1
HULL UNIT			
予備品			
予備品		000-025-051-00	
SPARE PARTS			
予備品		SP10-04201	1
SPARE PARTS			
工事材料			
INSTALLATION MATERIALS			
工事材料箱詰		CP10-08300	1
INSTALLATION MATERIALS (IN BOX)			
図書			
装備要領書(英)		IME-13440-*	1
INSTALLATION MANUAL (EN)			
装備要領書(和)		IMJ-13440-*	1
INSTALLATION MANUAL (JP)			
		000-178-773-1*	
		000-178-771-1*	

(略図の寸法は、参考値です。DIMENSIONS IN DRAWING FOR REFERENCE ONLY.)

C1344-Z17-C

(略図の寸法は、参考値です。DIMENSIONS IN DRAWING FOR REFERENCE ONLY.)



C1344-Z08-B

PACKING LIST

FSV-2504-J/E

100X-X-9892 -0 1/1

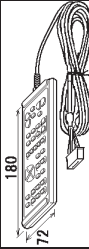
A-11

NAME	UNIT	OUTLINE	DESCRIPTION/CODE No.	Q'TY
ユニット リモート箱 REMOTE CONTROLLER			FSV-2504-*	1
工事材料 INSTALLATION MATERIALS			000-025-110-00 **	
工事材料 INSTALLATION MATERIALS			CPI0-07401	1
			001-120-170-00	

コード番号末尾の[**]は、選択品の代表コードを表します。
CODE NUMBER ENDING WITH "**" INDICATES THE CODE NUMBER OF REPRESENTATIVE MATERIAL

型式/コード番号が2段の場合、下段より上段に代わる過渡期品であり、どちらが入っています。なお、品質は変わりません。
TWO TYPES AND CODES MAY BE LISTED FOR AN ITEM. THE LOWER PRODUCT MAY BE SHIPPED IN PLACE OF THE UPPER PRODUCT. QUALITY IS THE SAME.

(略図の寸法は、参考値です。 DIMENSIONS IN DRAWING FOR REFERENCE ONLY.)

C1344-Z20-A







A-12

FURUNO

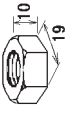
CODE NO.	001-349-780-00	100X-X-9420 -1
TYPE	CPI0-09301	1/1

工事材料表

INSTALLATION MATERIALS

番号 NO.	名称 NAME	略図 OUTLINE	型名/規格 DESCRIPTIONS	数量 Q'TY	用途/備考 REMARKS
1	圧着端子 CRIMP-ON LUG		FV2-4 BLD K CODE NO. 000-157-247-11	3	
2	六角ナット HEXAGONAL NUT		M12 SUS304 CODE NO. 000-167-491-10	8	
3	フラットワッシャー FLAT WASHER		M12 SUS304 CODE NO. 000-167-446-10	8	
4	スプリングワッシャー SPRING WASHER		M12 SUS304 CODE NO. 000-167-397-10	8	
5	六角ボルト HEXAGONAL HEAD BOLT		M12x60 SUS304 CODE NO. 000-164-116-10	4	
6	バンドヘッドネジ BINDING HEAD SCREW		M4x8 SUS304 CODE NO. 000-176-672-10	6	
7	銅板 COPPER STRAP		WEA-1004-0 ROHS CODE NO. 500-310-040-10	1	

(略図の寸法は、参考値です。 DIMENSIONS IN DRAWING FOR REFERENCE ONLY.)

FURUNO ELECTRIC CO., LTD.

C1344-M13-B

FURUNO

CODE NO.	001-349-820-00	10CX-X-9421-0
TYPE	CP10-09303	1/1

工事材料表

番号 NO.	名称 NAME	略図 OUTLINE	型名/規格 DESCRIPTIONS	数量 QTY	用途/備考 REMARKS
1	防振カバー(1枚) VIB. ISO COVER (1) REV1. ED.		10-089-6724-0 CODE NO. 100-398-180-10	1	

型式/コード番号が2段の場合、下段より上段に代わる標準部品であり、どちらかが入っています。なお、品質は変わりません。
TWO TYPES AND CODES MAY BE LISTED FOR AN ITEM. THE LOWER PRODUCT MAY BE SHIPPED IN PLACE OF THE UPPER PRODUCT.
QUALITY IS THE SAME.
(略図の寸法は、参考値です。 DIMENSIONS IN DRAWING FOR REFERENCE ONLY.)

FURUNO ELECTRIC CO., LTD.

C1344-M14-A

FURUNO

CODE NO.	001-288-610-00	10CX-X-9402-0
TYPE	CP10-07801	1/1

工事材料表

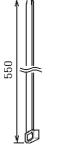
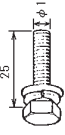
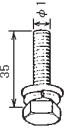





番号 NO.	名称 NAME	略図 OUTLINE	型名/規格 DESCRIPTIONS	数量 QTY	用途/備考 REMARKS
1	ケーブルタイ CABLE TIE		CY-5508 CODE NO. 000-102-166-10	10	
2	六角ワッシャー HEX. WASHER HEAD BOLT-B		M10X25 SUS304 CODE NO. 000-179-083-10	6	
3	六角ワッシャー HEX. WASHER HEAD BOLT-B		M12X35 SUS304 CODE NO. 000-179-084-10	6	

型式/コード番号が2段の場合、下段より上段に代わる標準部品であり、どちらかが入っています。なお、品質は変わりません。
TWO TYPES AND CODES MAY BE LISTED FOR AN ITEM. THE LOWER PRODUCT MAY BE SHIPPED IN PLACE OF THE UPPER PRODUCT.
QUALITY IS THE SAME.
(略図の寸法は、参考値です。 DIMENSIONS IN DRAWING FOR REFERENCE ONLY.)

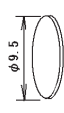
FURUNO ELECTRIC CO., LTD.

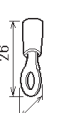

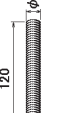
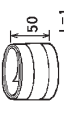

C1344-M02-A

FSV-253/254

CODE NO.		100X-X-9403-1	
TYPE		CP10-08300	
工事材料表			
INSTALLATION MATERIALS			
番号 NO.	名称 NAME	略図 OUTLINE	用途/備考 REMARKS
1	ブラインドシールMZ.5 BLIND SEAL MZ.5		数量 Q'TY 1
2	Oリング (V) O-RING		数量 Q'TY 1
3	圧着端子 CRIMP-ON LUG		数量 Q'TY 3
4	六角ナット 1/2 HEX. NUT		数量 Q'TY 48
5	六角ナット平座金 FLAT WASHER		数量 Q'TY 41
6	ハネ座金 SPRING WASHER		数量 Q'TY 24
7	六角ボルト 全長 HEXAGONAL HEAD SCREW		数量 Q'TY 17
8	銅テープ COPPER STRAP		数量 Q'TY 1

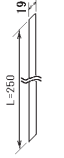
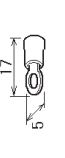
(略図の寸法は、参考値です。 DIMENSIONS IN DRAWING FOR REFERENCE ONLY.)

FURUNO ELECTRIC CO., LTD.

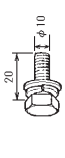
CODE NO.		100X-X-9406-2	
TYPE		CP10-08001	
工事材料表			
INSTALLATION MATERIALS			
番号 NO.	名称 NAME	略図 OUTLINE	用途/備考 REMARKS
1	導電性布テープ CONDUCTIVE TAPE		数量 Q'TY 1
2	圧着端子 CRIMP-ON LUG		数量 Q'TY 8
3	圧着端子 CRIMP-ON LUG		数量 Q'TY 18
4	六角ナット平座金 FLAT WASHER		数量 Q'TY 2
5	六角ナット 1/2 HEX NUT		数量 Q'TY 2
6	ハネ座金 SPRING WASHER		数量 Q'TY 2
7	六角ボルト平座金 HEX WASHER HEAD BOLT-B		数量 Q'TY 2

(略図の寸法は、参考値です。 DIMENSIONS IN DRAWING FOR REFERENCE ONLY.)

FURUNO ELECTRIC CO., LTD.

FURUNO

CODE NO.	000-025-104-00	10CX-X-9407-0	1/1
TYPE	CP10-08200		

工事材料表

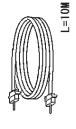
INSTALLATION MATERIALS			
番号 NO.	名称 NAME	略図 OUTLINE	用途/備考 REMARKS
1	ケーブル(組品) CABLE ASSEMBLY	 L=10M	
		型名/規格 DESCRIPTIONS	数量 QTY
		10CA10053 #10M*	1
		CODE NO. 001-289-560-00	

型式/コード番号が2図の場合、下図より上図に代わる通線部品であり、どちらかが入っています。なお、品質は変わりません。
TWO TYPES AND CODES MAY BE LISTED FOR AN ITEM. THE LOWER PRODUCT MAY BE SHIPPED IN PLACE OF THE UPPER PRODUCT.
QUALITY IS THE SAME.
(略図の寸法は、参考値です。 DIMENSIONS IN DRAWING FOR REFERENCE ONLY.)

FURUNO ELECTRIC CO., LTD.

C1344-M05-A

FURUNO

CODE NO.	000-025-113-00	10CX-X-9409-1	1/1
TYPE	CP10-07800		

工事材料表

INSTALLATION MATERIALS			
番号 NO.	名称 NAME	略図 OUTLINE	用途/備考 REMARKS
1	ケーブル(組品) CABLE ASSEMBLY	 L=10M	10本/セット 10PCS/SET
		型名/規格 DESCRIPTIONS	数量 QTY
		S10-20-10	1
		CODE NO. 001-324-780-00	

型式/コード番号が2図の場合、下図より上図に代わる通線部品であり、どちらかが入っています。なお、品質は変わりません。
TWO TYPES AND CODES MAY BE LISTED FOR AN ITEM. THE LOWER PRODUCT MAY BE SHIPPED IN PLACE OF THE UPPER PRODUCT.
QUALITY IS THE SAME.
(略図の寸法は、参考値です。 DIMENSIONS IN DRAWING FOR REFERENCE ONLY.)

FURUNO ELECTRIC CO., LTD.

C1344-M06-B

CODE NO.	001-112-510-00	100Y-X-9402-1	1/1
TYPE	CP10-07301		

工事材料表

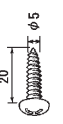
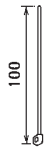
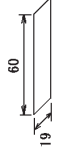

INSTALLATION MATERIALS		FSV-8502			
番号 NO.	名称 NAME	略図 OUTLINE	型名/規格 DESCRIPTIONS	数量 QTY	用途/備考 REMARKS
1	セルフタッピングネジ SELF-TAPPING SCREW		5X20 SUS304 CODE NO. 000-162-608-10	4	
2	ケーブルタイ CABLE TIE		CV-100N CODE NO. 000-162-167-10	4	
3	導電性布テープ CONDUCTIVE CLOTH TAPE		DK02CFR-19 *60MM* CODE NO. 000-189-613-10	1	

(略図の寸法は、参考値です。 DIMENSIONS IN DRAWING FOR REFERENCE ONLY.)

FURUNO ELECTRIC CO., LTD.

CODE NO.	001-269-290-00	100X-X-9418-1	1/1
TYPE	CP10-08101		

工事材料表

INSTALLATION MATERIALS					
番号 NO.	名称 NAME	略図 OUTLINE	型名/規格 DESCRIPTIONS	数量 QTY	用途/備考 REMARKS
1	ブラインドシール BLIND SEAL		05-104-6619F-0 CODE NO. 100-372-560-10	1	
2	圧着端子 CRIMP-ON LUG		FV5.9-4(LF) TEL K CODE NO. 000-166-744-11	3	
3	銅テープ COPPER STRAP		MEA-1004-0 ROHS CODE NO. 500-310-040-10	1	

(略図の寸法は、参考値です。 DIMENSIONS IN DRAWING FOR REFERENCE ONLY.)

FURUNO ELECTRIC CO., LTD.

CODE NO.	001-268-990-00	10CX-X-9301-2	1/1
TYPE	SPI0-03901	BOX NO.	P

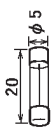
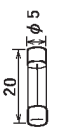
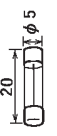
SHIP NO.	SPARE PARTS LIST FOR		U S E		REMARKS/CODE NO.	
			WORKING	SPARE		
ITEM NO.	NAME OF PART	OUTLINE	DWG. NO. OR TYPE NO.	QUANTITY PER SET	PER VES	SETS PER VESSEL
1	セラミック FUSE		D52-8A-COLLUM	1	1	
2	ガラス FUSE		F0MB-A 250V 3A PBF	2	2	000-178-350-11
3	ガラス FUSE		F0MB-S 250V 10A PBF	2	2	000-157-568-10
MFR'S NAME	FURUNO ELECTRIC CO., LTD.		DWG NO.	C1344-P01-C	1/1	

(略図の寸法は、参考値です。 DIMENSIONS IN DRAWING FOR REFERENCE ONLY.)

CODE NO.	001-269-280-00	10CX-X-9303-1	1/1
TYPE	SPI0-04201	BOX NO.	P

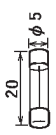
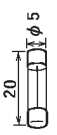
SHIP NO.	SPARE PARTS LIST FOR		U S E		REMARKS/CODE NO.	
			WORKING	SPARE		
ITEM NO.	NAME OF PART	OUTLINE	DWG. NO. OR TYPE NO.	QUANTITY PER SET	PER VES	SETS PER VESSEL
1	セラミック FUSE		F0MB-A 250V 1A PBF	2	2	000-157-496-10
2	ガラス FUSE		F0MB-A 250V 2A PBF	3	3	000-157-497-10
MFR'S NAME	FURUNO ELECTRIC CO., LTD.		DWG NO.	C1344-P02-B	1/1	

(略図の寸法は、参考値です。 DIMENSIONS IN DRAWING FOR REFERENCE ONLY.)

表 1 TABLE 1

寸法区分 (mm) DIMENSION	公差 (mm) TOLERANCE
L ≤ 50	±1.5
50 < L ≤ 100	±2.5
100 < L ≤ 500	±3

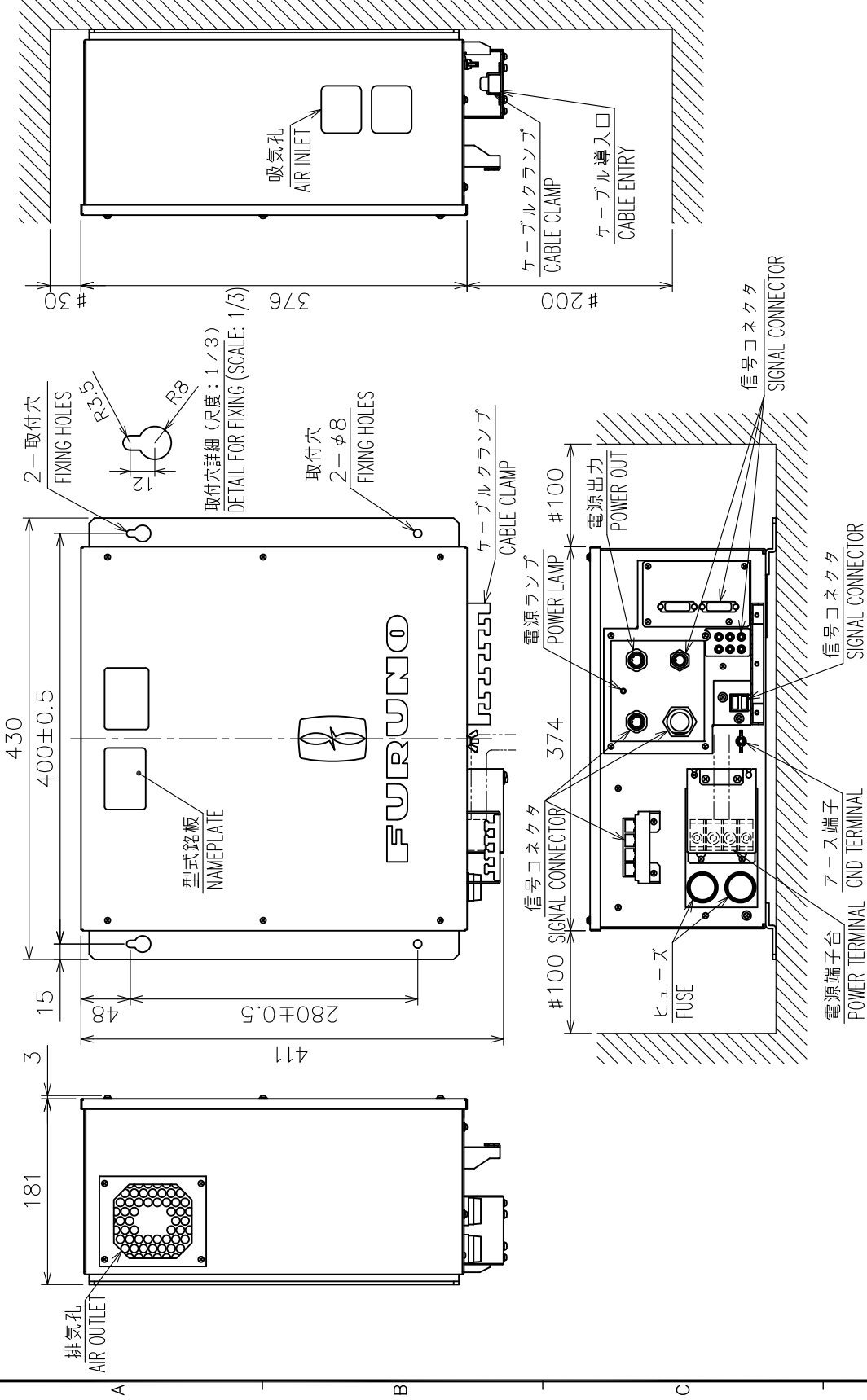

注 記

- 1) 指定外の寸法公差は表 1 による。
- 2) # 印寸法は最小サービスマン間寸法とする。
- 3) 取付にはトラスタツピネジ呼び径 6 × 30 を使用のこと。

NOTE

1. TABLE 1 INDICATES TOLERANCE OF DIMENSIONS WHICH IS NOT SPECIFIED.
2. # MINIMUM SERVICE CLEARANCE.
3. USE TAPPING SCREWS Ø6x30 FOR FIXING THE UNIT.

DRAWN	8/Feb/2019	I. YAMASAKI	TITLE	FSV-2503
CHECKED	8/Feb/2019	H. MAKI	名称	制御部
APPROVED	8/Feb/2019	H. MAKI	外寸図	FSV-25/28W
SCALE	1/6	1/5	NAME	PROCESSOR UNIT
DWG.No.	C1344-G08-B	104	REF.No.	10-089-350G-1
				OUTLINE DRAWING

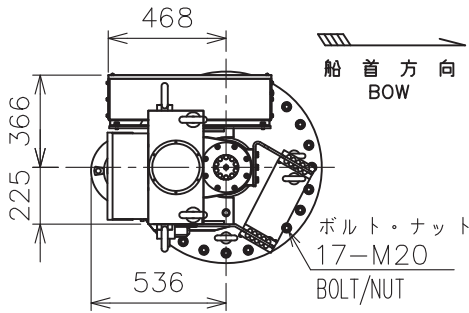

船首方向
BOW

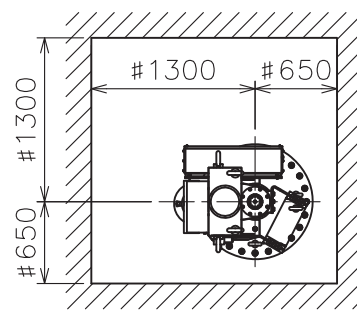

サービス空間 (尺度: 1/50)
MAINTENANCE CLEARANCE (SCALE: 1/50)

表1 TABLE 1

寸法区分 (mm) DIMENSION	公差 (mm) TOLERANCE
$L \leq 50$	± 1.5
$50 < L \leq 100$	± 2.5
$100 < L \leq 500$	± 3
$500 < L \leq 1000$	± 4
$1000 < L \leq 2000$	± 5
$2000 < L \leq 4000$	± 7

表2 TABLE 2

ユニット UNIT	質量 (kg±10%) MASS
上下装置本体 (接続箱除く) HULL UNIT (W/O JUNCTION BOX)	830
格納タンク RETRUCTION TANK	260
送受波器 (ケーブル含む) TRANSDUCER (W/ CABLE)	300
総質量 TOTAL	1390

アイナット
2-M30
EYE-NUTS
アイボルト
2-M30
EYE-BOLTS

型式銘板
NAMEPLATE
189

上下動制御器
RAISE/LOWER
CONTROL BOX

非常停止ボタン
EMERGENCY SWITCH

接続箱
JUNCTION BOX

手動ハンドル
HANDLE

ケーブル
CABLE

ケーブル
CABLE

注油口
OIL ENTRY
4-M24アイボルト
EYE-BOLTS

注油口
OIL ENTRY
ナット
7-M20
NUTS

6-防食亜鉛
ANTICORROSIVE
ZINC PLATE

格納タンク
TANK

送受波器
TRANSDUCER

注記

- 1) 指定外の寸法公差は表1による。
- 2) #印寸法は最小サービス空間寸法とする。

NOTE

1. TABLE 1 INDICATES TOLERANCE OF DIMENSIONS WHICH IS NOT SPECIFIED.
2. #: MINIMUM SERVICE CLEARANCE.

DRAWN 24/Jul/2014 I.YAMASAKI	TITLE FSV-253
CHECKED 24/Jul/2014 H.MAKI	名称 上下装置 (1200ストローク)
APPROVED 24/Jul/2014 H.MAKI	外寸図
SCALE 1/30	NAME HULL UNIT (1200 TRAVEL)
DWG. No. C1344-G01-C	REF. No. 10-089-550G-1
OUTLINE DRAWING	



表1 TABLE 1

寸法区分 (mm) DIMENSION	公差 (mm) TOLERANCE
L ≤ 50	±1.5
50 < L ≤ 100	±2.5
100 < L ≤ 500	±3
500 < L ≤ 1000	±4
1000 < L ≤ 2000	±5
2000 < L ≤ 4000	±7

表2 TABLE 2

ユニット UNIT	質量 (kg±10%) MASS
上下装置本体 (接続箱除く) HULL UNIT (W/O JUNCTION BOX)	880
格納タンク RETRUCTION TANK	260
送受波器 (ケーブル含む) TRANSDUCER (W/ CABLE)	300
総質量 TOTAL	1440

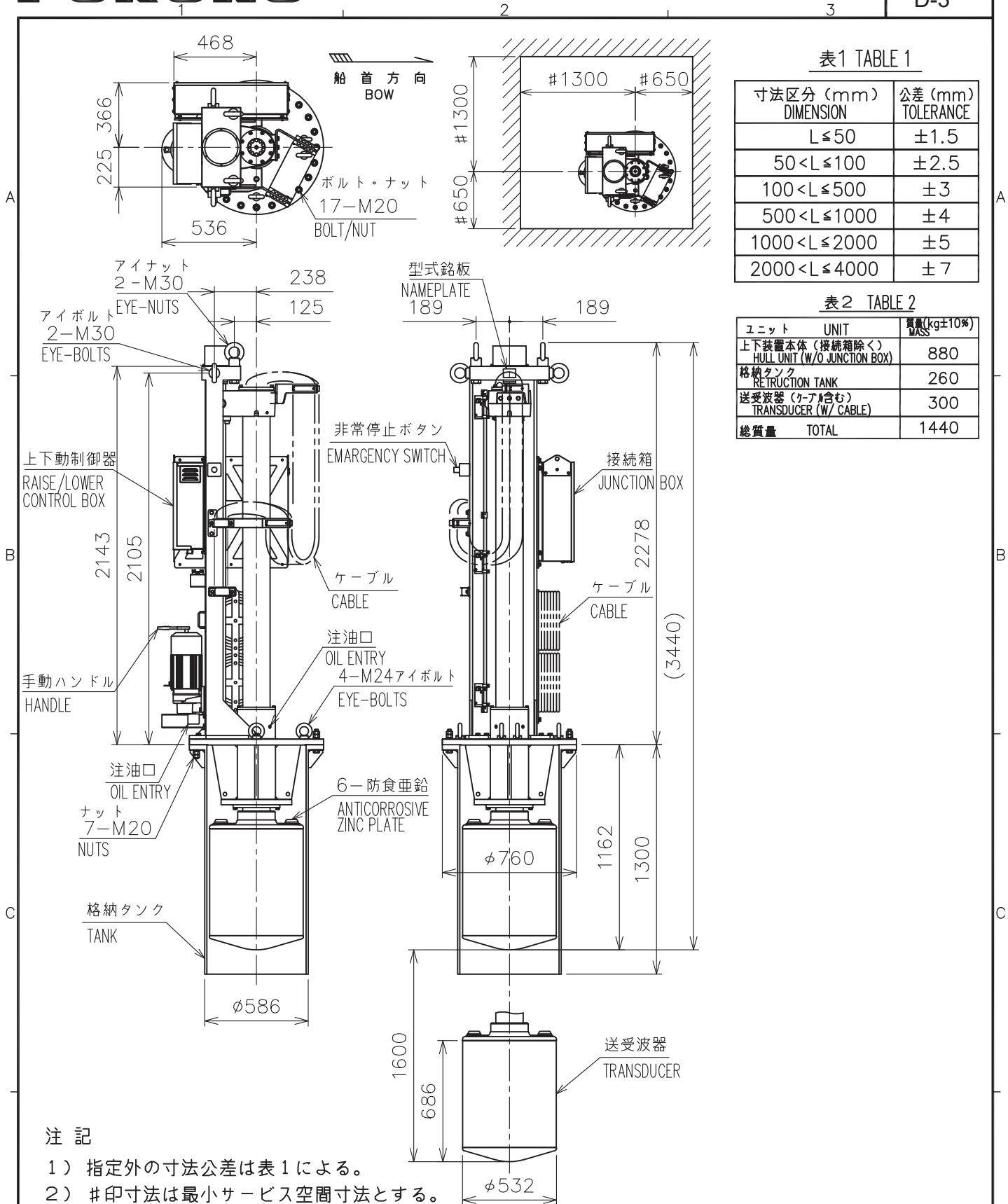
注記

- 1) 指定外の寸法公差は表1による。
- 2) #印寸法は最小サービス空間寸法とする。

NOTE

1. TABLE 1 INDICATES TOLERANCE OF DIMENSIONS WHICH IS NOT SPECIFIED.
2. #: MINIMUM SERVICE CLEARANCE.

DRAWN 24/Jul/2014 T.YAMASAKI	TITLE FSV-254
CHECKED 24/Jul/2014 H.MAKI	名称 上下装置 (1600ストローク)
APPROVED 24/Jul/2014 H.MAKI	外寸図
SCALE 1/30	NAME HULL UNIT (1600 TRAVEL)
DWG. No. C1344-G02-C	REF. No. 10-089-551G-1
OUTLINE DRAWING	

表 1 TABLE 1

寸法区分 (mm) DIMENSION	公差 (mm) TOLERANCE
L ≤ 50	±1.5
50 < L ≤ 100	±2.5
100 < L ≤ 500	±3

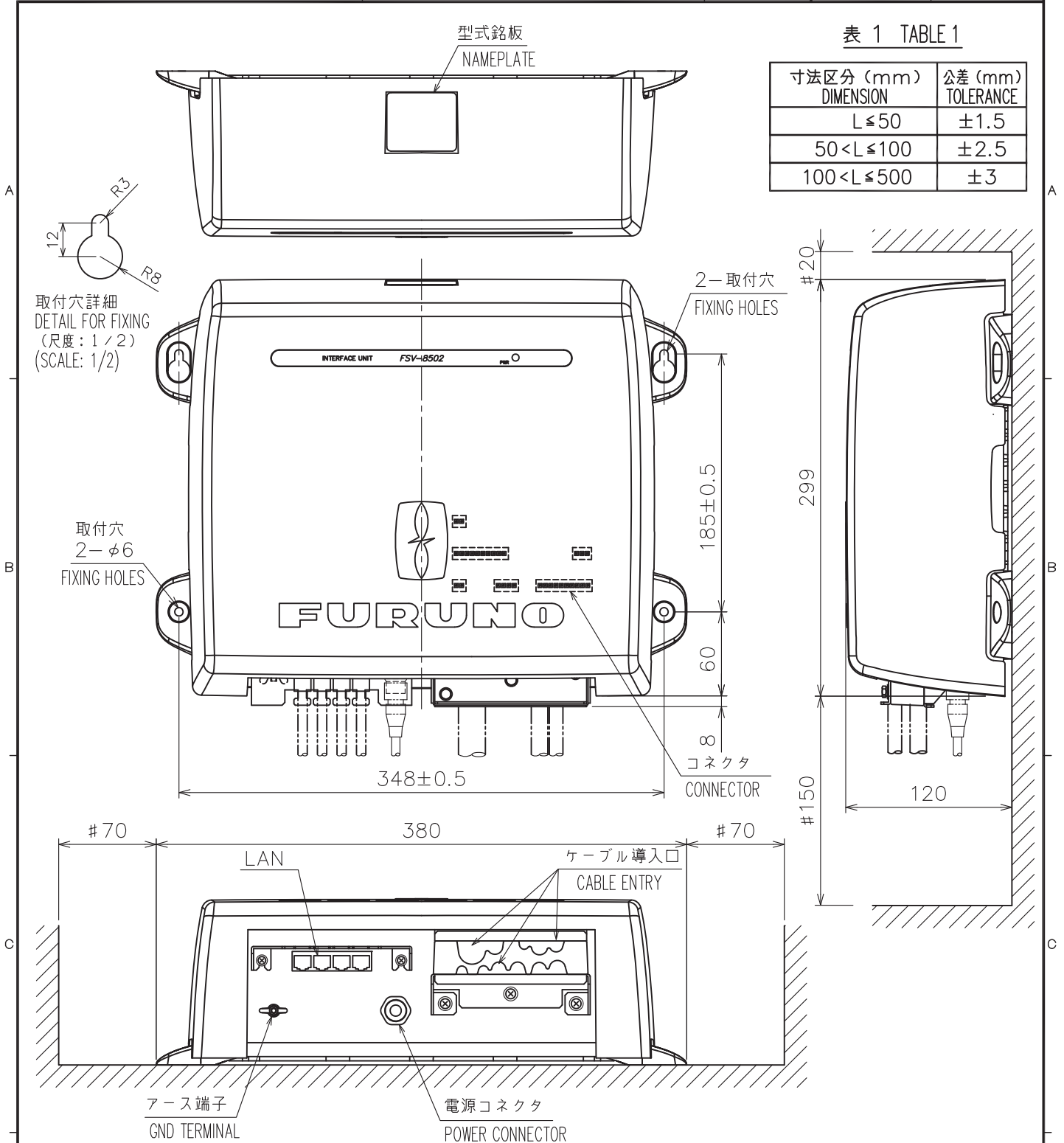

- 注 記 1) 指定外の寸法公差は表 1 による。
 2) # 印寸法は最小サービス空間寸法とする。
 3) 取付用ネジはトラスタッピンネジ呼び径5×20を使用のこと。

- NOTE 1. TABLE 1 INDICATES TOLERANCE OF DIMENSIONS WHICH IS NOT SPECIFIED.
 2. #: MINIMUM SERVICE CLEARANCE.
 3. USE TAPPING SCREWS $\phi 5 \times 20$ FOR FIXING THE UNIT.

DRAWN	9/Sep/2011 T.YAMASAKI	TITLE	FSV-8502
CHECKED	9/Sep/2011 H.MAKI	名称	インターフェイスユニット
APPROVED	13/Sep/2011 Y.NISHIYAMA		外寸図
SCALE	1/4	MASS	3.4 ±10% kg
DWG. No.	C1335-G02-C	REF. No.	10-088-350G-2
		NAME	INTERFACE UNIT OUTLINE DRAWING

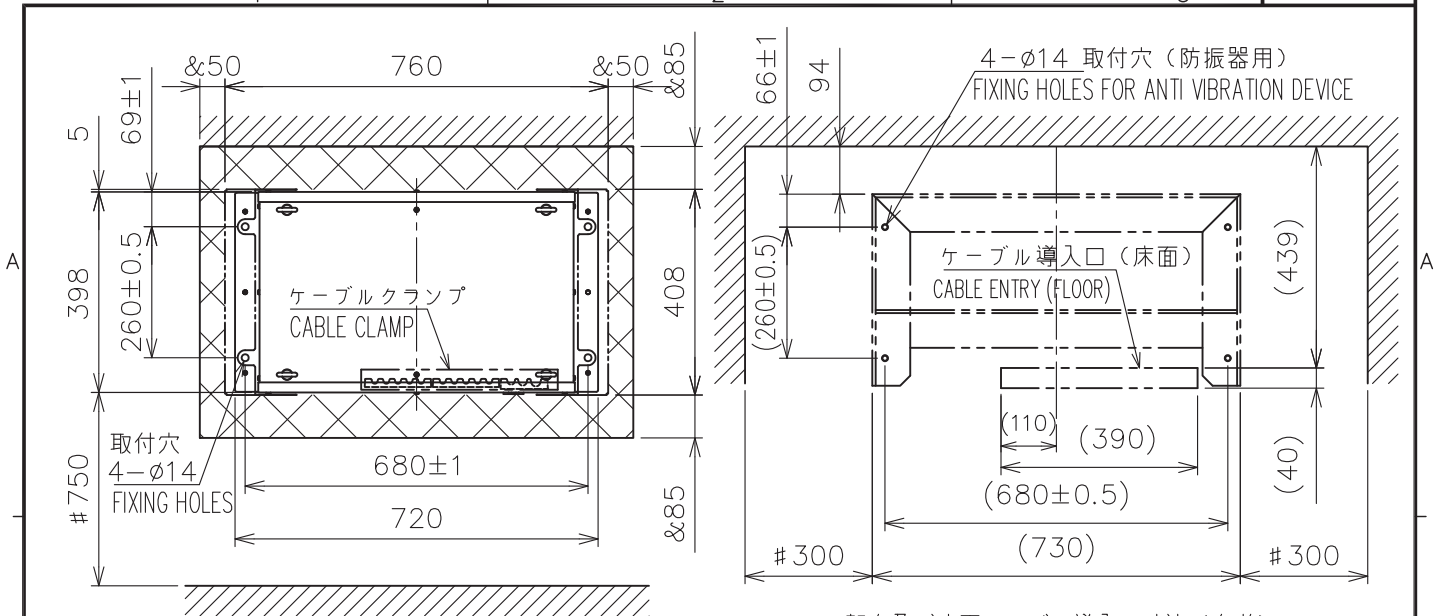

架台及び床面ケーブル導入口寸法 (参考)
MOUNTING BASE AND CABLE ENTRY DIMENSIONS (REFERENCE)

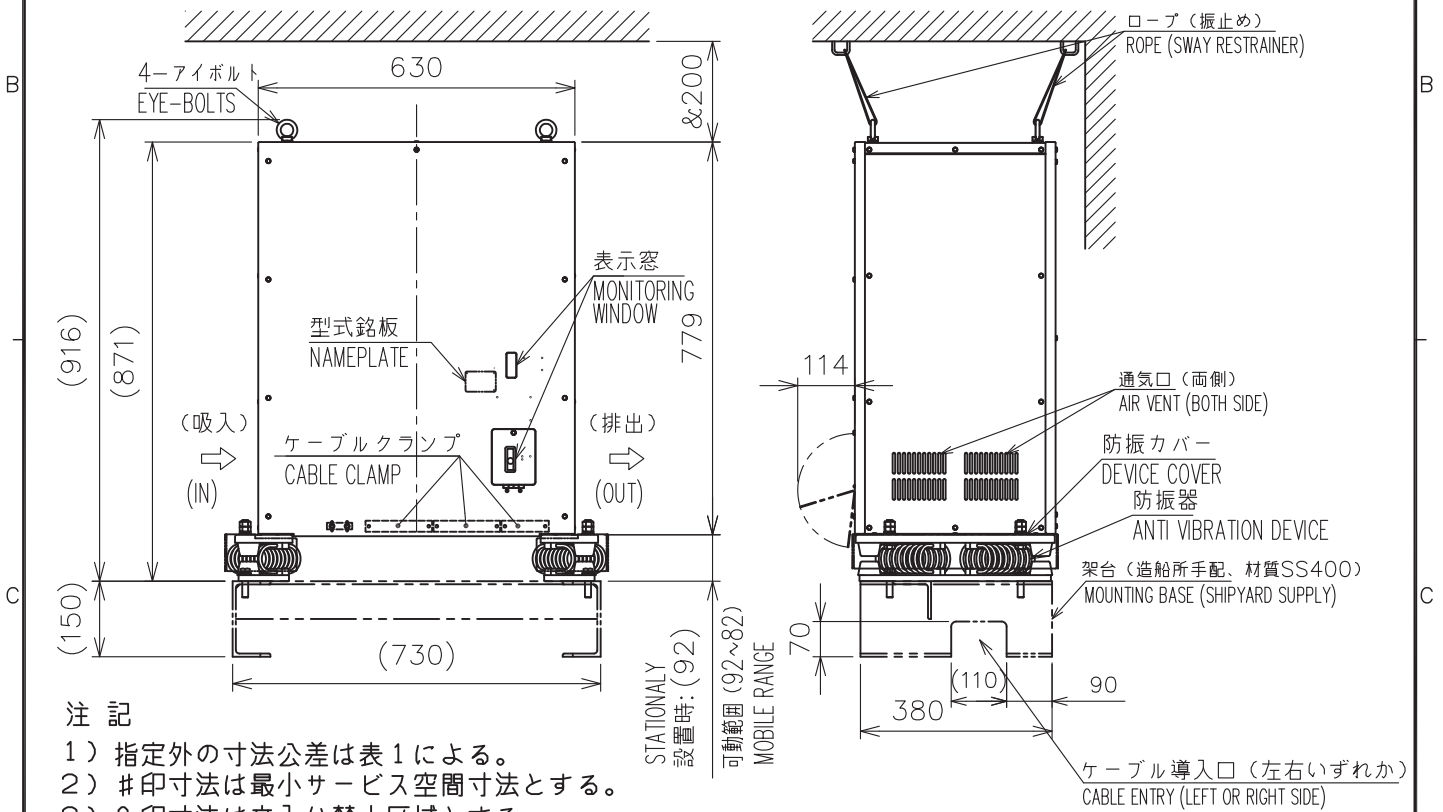

注記

- 1) 指定外の寸法公差は表 1 による。
- 2) #印寸法は最小サービス空間寸法とする。
- 3) &印寸法は立入り禁止区域とする。
- 4) 取付用ネジはM 12 ボルト (SUS304) を使用のこと。
- 5) 直接床置きの場合のみ床面ケーブル導入口を設けること。

NOTE

1. TABLE 1 INDICATES TOLERANCE OF DIMENSIONS WHICH IS NOT SPECIFIED.
2. #: MINIMUM SERVICE CLEARANCE.
3. &: SAFETY CLEARANCE.
4. USE M12 BOLTS (SUS304) FOR FIXING THE UNIT.
5. MAKE A CABLE ENTRY HOLE ON FLOOR WHEN THE MOUNTING BASE IS NOT USED.

表 1 TABLE 1

寸法区分 (mm) DIMENSION	公差 (mm) TOLERANCE
$L \leq 50$	± 1.5
$50 < L \leq 100$	± 2.5
$100 < L \leq 500$	± 3
$500 < L \leq 1000$	± 4

DRAWN 18/Apr/2016 T.YAMASAKI	TITLE FSV-251
CHECKED 18/Apr/2016 H.MAKI	名称 送受信装置
APPROVED 14/Apr/2015 H.MAKI	外寸図
SCALE 1/15	NAME TRANSCEIVER UNIT
MASS 123 ±10% kg	OUTLINE DRAWING
DWG. No. C1344-G03-F	REF. No. 10-089-650G-3

表1 TABLE 1

寸法区分 (mm) DIMENSION	公差 (mm) TOLERANCE
L ≤ 50	±1.5
50 < L ≤ 100	±2.5
100 < L ≤ 500	±3

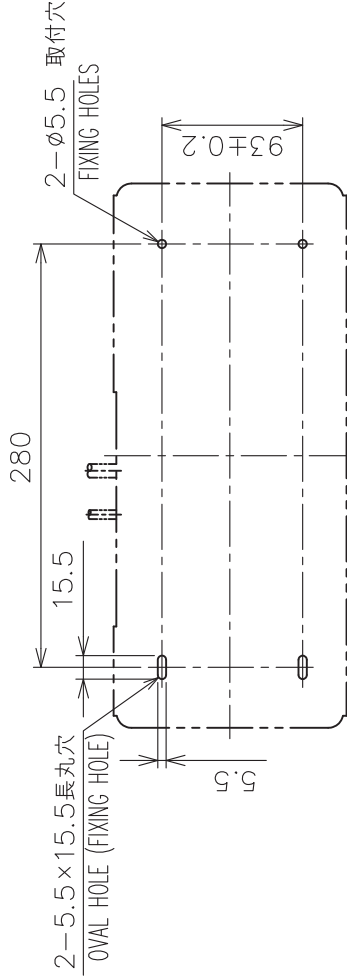

取付寸法

FIXING DIMENSIONS

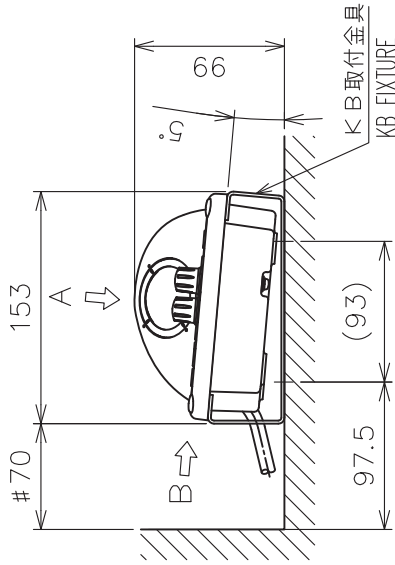

矢視 A

VIEW A

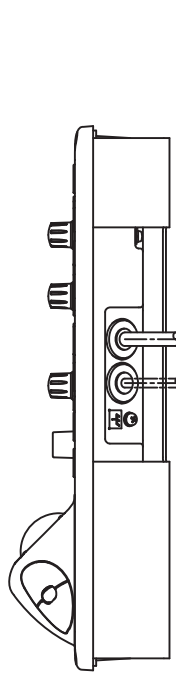

矢視 B

VIEW B

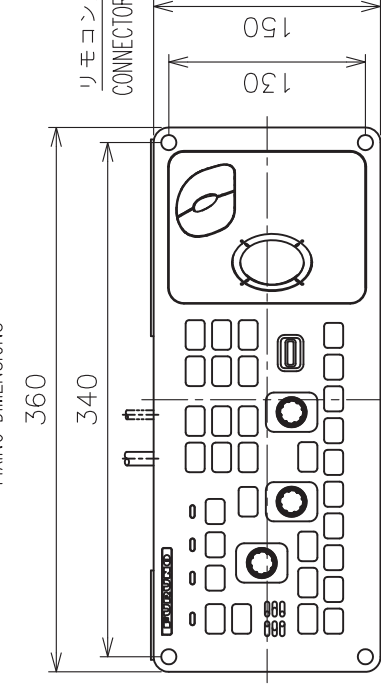

警告ラベル

WARNING LABEL

底面

BOTTOM VIEW

型式銘板

NAMEPLATE

注 記

- 1) 指定外の寸法公差は表1による。
- 2) #印寸法は最小サービス空間寸法とする。
- 3) 取付用ネジは+バイインドットピン1シユ呼び径5×20を使用のこと。

NOTE

1. TABLE 1 INDICATES TOLERANCE OF DIMENSIONS WHICH IS NOT SPECIFIED.
2. #: MINIMUM SERVICE CLEARANCE.
3. USE BINDING TAPPING SCREWS φ5x20 FOR FIXING THE UNIT.

DRAWN	21/Nov/2013	I. YAMASAKI	TITLE	FSV-2501
CHECKED	25/Nov/2013	H. MAKI	名称	操作部 (取付金具)
APPROVED	27/Nov/2013	H. MAKI	外寸図	
SCALE	1/5	質量 3.8 kg 質量は5mケーブルを含む。 MASS INCLUDES 5m CABLE.	NAME	CONTROL UNIT (KB FIXTURE MOUNT)
DWG.No.	C1344-606-A	REF.No.	10-089-251G-0	OUTLINE DRAWING

表1 TABLE 1

寸法区分 (mm) DIMENSION	公差 (mm) TOLERANCE
L ≤ 50	±1.5
50 < L ≤ 100	±2.5
100 < L ≤ 500	±3

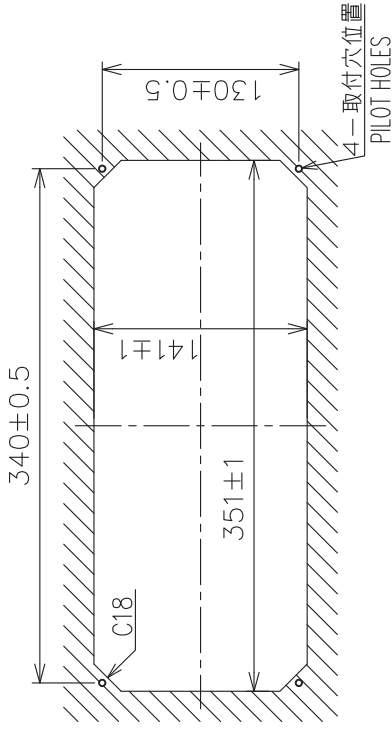
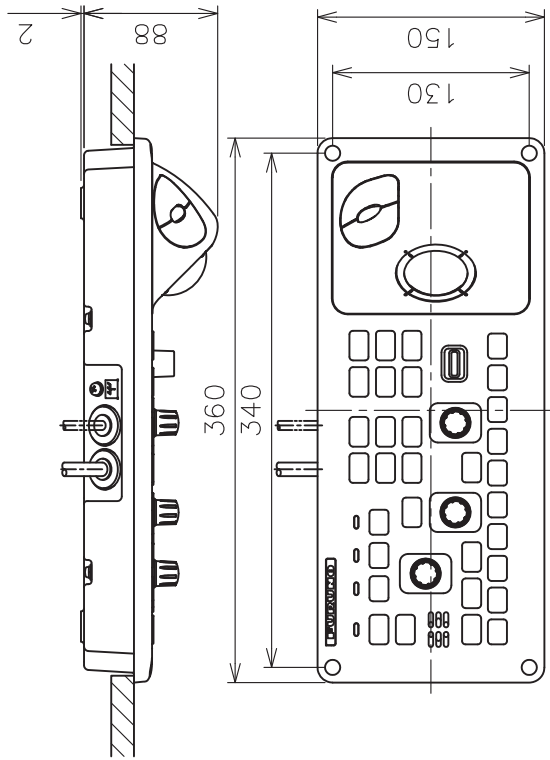

リモコンケーブル (オプション)
REMOTE CABLE (OPTION)

リモコン用コネクタ
アース端子
GND TERMINAL
CONNECTOR TO REMOTE

信号ケーブル
SIGNAL CABLE

警告ラベル
WARNING LABEL

型式銘板
NAMEPLATE

底面図
BOTTOM VIEW

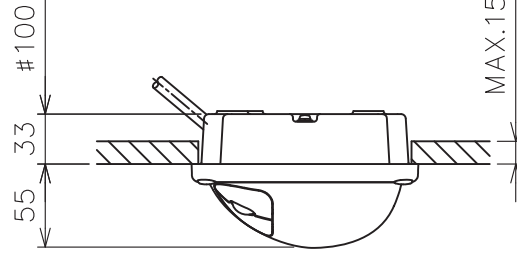

注 記

- 1) 指定外の寸法公差は表1による。
- 2) #印寸法は最小サービスマウント寸法とする。
- 3) 取付用ネジは+バインドットピン1シュ呼び径5×20を使用のこと。

NOTE

1. TABLE 1 INDICATES TOLERANCE OF DIMENSIONS WHICH IS NOT SPECIFIED.
2. #: MINIMUM SERVICE CLEARANCE.
3. USE BINDING TAPPING SCREWS $\phi 5 \times 20$ FOR FIXING THE UNIT.

DRAWN	21/Nov/2013	I. YAMASAKI	TITLE	FSV-2501
CHECKED	25/Nov/2013	H. MAKI	名称	操作部 (埋込装備)
APPROVED	27/Nov/2013	H. MAKI	外寸図	
SCALE	1/5	質量は5mケーブルを含む。 ±10% MASS INCLUDES 5m CABLE.	NAME	CONTROL UNIT (FLUSH MOUNT)
DMC No.	C1344-G05-A	REF. No.	10-089-250G-0	OUTLINE DRAWING



表 1 TABLE 1

寸法区分 (mm) DIMENSION	公差 (mm) TOLERANCE
$L \leq 50$	± 1.5
$50 < L \leq 100$	± 2.5
$100 < L \leq 500$	± 3

NOTE 1. TABLE 1 INDICATES TOLERANCE OF DIMENSIONS WHICH IS NOT SPECIFIED.
 2. # : MINIMUM SERVICE CLEARANCE.
 3. SELECT SIDE OR BOTTOM FOR CABLE ENTRY.
 4. THICKNESS (P): 10 MAX.

DRAWN	g/Sep/2011	T.YAMASAKI	TITLE	FSV-853
CHECKED	g/Sep/2011	H.MAKI	名称	簡易操作部 (埋込装備)
APPROVED	13/Sep/2011	Y.NISHIYAMA	外寸図	
SCALE	1/3	MASS 1.4 kg	NAME	SUB CONTROL UNIT (FLUSH MOUNT)
DWG.No.	C1335-G08-B	REF.No.		OUTLINE DRAWING
				10-088-853G-0

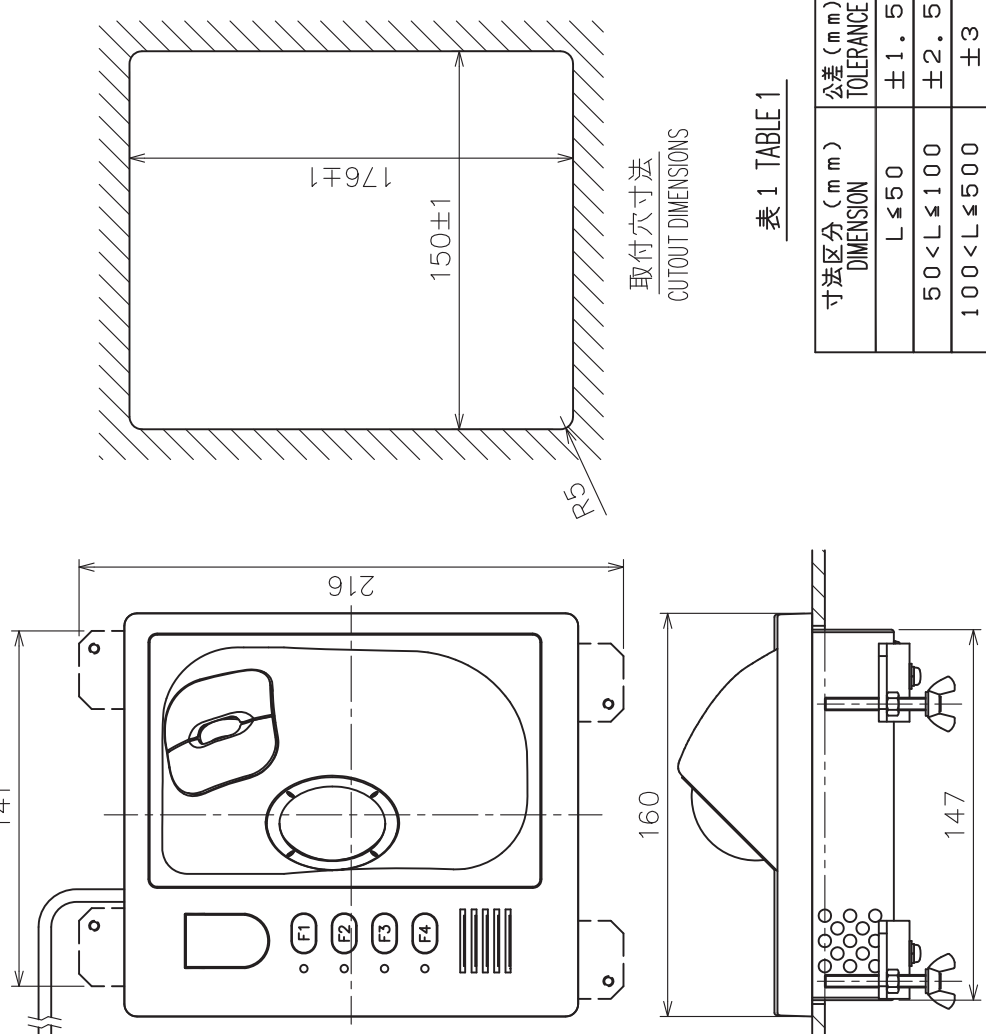
- 注記 1) 指定外の寸法公差は表 1 による。
 2) # 印寸法は最小サービス空間寸法とする。
 3) ケーブル導入口は側面・底面から選択のこと。
 4) 板厚 (P) は最大 10 とする。

表 1 TABLE 1

寸法区分 (mm) DIMENSION	公差 (mm) TOLERANCE
L ≤ 50	± 1.5
50 < L ≤ 100	± 2.5
100 < L ≤ 500	± 3

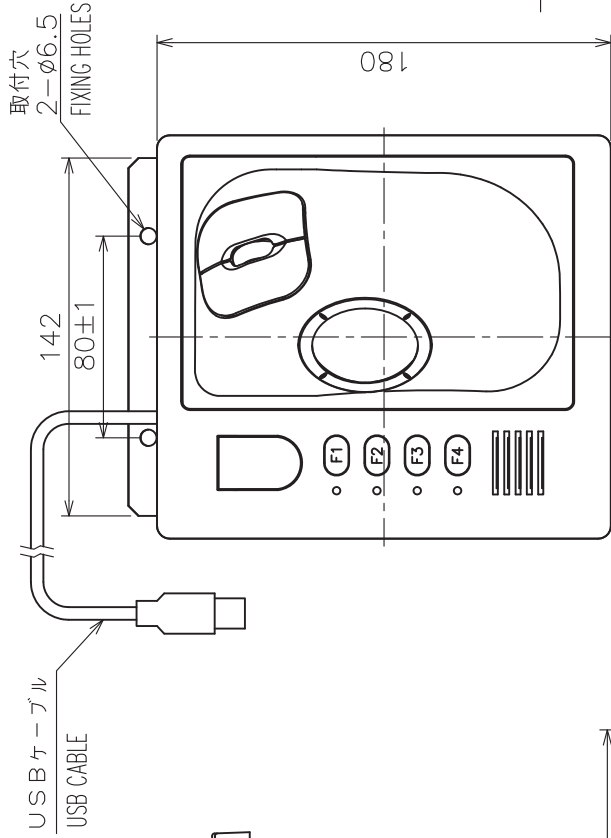

矢視 A
VIEW A

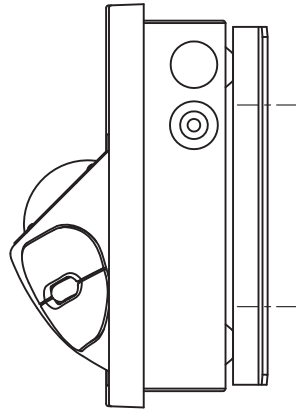

矢視 D
VIEW D

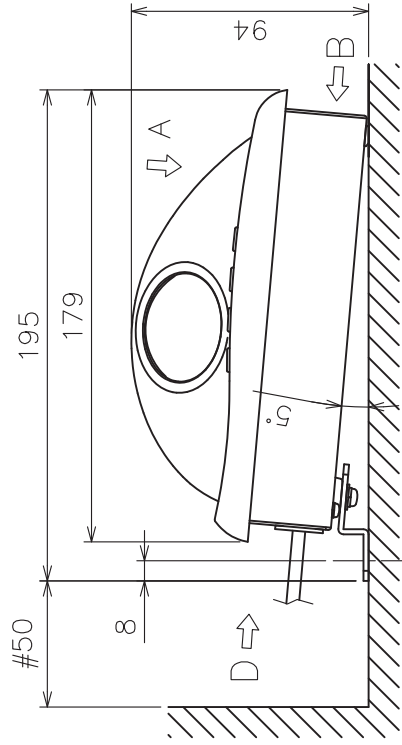

矢視 B
VIEW B

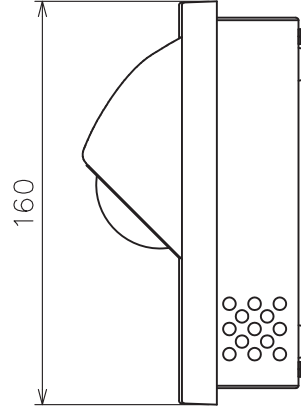

- 注 記 1) 指定外の寸法公差は表 1 による。
 2) # 印寸法は最小サービスペース寸法とする。
 3) 取付用ネジはトラスタップピンネジ呼び径 6、または M6 ボルトを使用のこと。
- NOTE 1. TABLE 1 INDICATES TOLERANCE OF DIMENSIONS WHICH IS NOT SPECIFIED.
 2. #: MINIMUM SERVICE CLEARANCE.
 3. USE TAPPING SCREWS $\phi 6$ OR M6 BOLTS FOR FIXING THE UNIT.

DRAWN	9/Sep/2011	T.YAMASAKI	TITLE	FSV-853
CHECKED	9/Sep/2011	H.MAKI	名称	簡易操作部 (取付金具)
APPROVED	13/Sep/2011	Y.NISHIYAMA	外寸図	
SCALE	1/3	質量 1.4 kg ±10% 質量はケーブル (5m) を含む。 MASS INCLUDES 5m CABLE.	NAME	SUB CONTROL UNIT (W/ FIXTURE)
DWG.No.	C1335-G07-B	REF.No.	10-088-853G-0	OUTLINE DRAWING

表 1 TABLE 1

寸法区分 (mm) DIMENSION	公差 (mm) TOLERANCE
$L \leq 50$	± 1.5
$50 < L \leq 100$	± 2.5
$100 < L \leq 500$	± 3

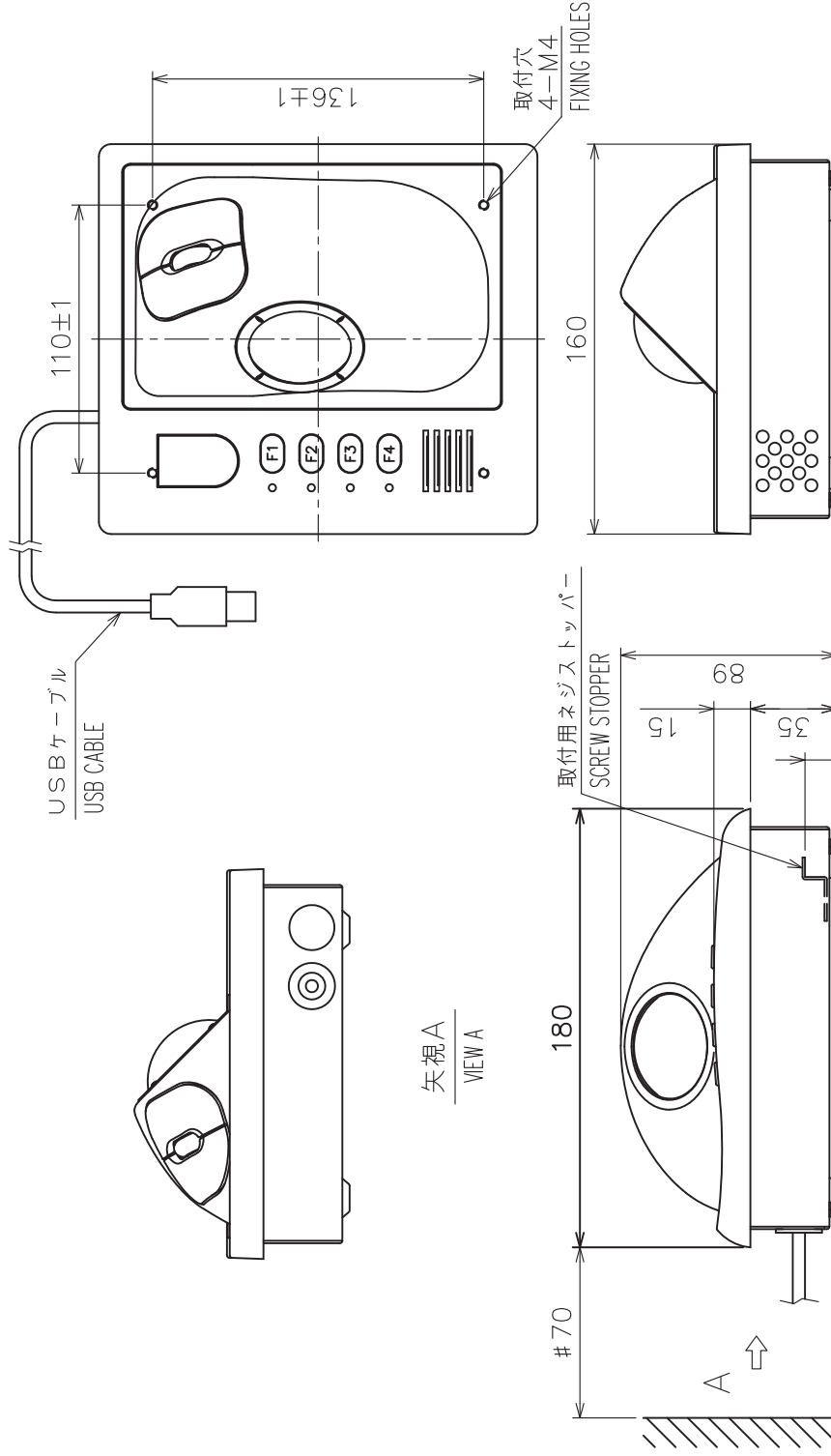

矢視 A
VIEW A

注 記

- 1) 指定外の寸法公差は表 1 による。
- 2) # 印寸法は最小サービスインスペーシングとする。
- 3) 取付用ネジはセムスB (M4x12) を使用のこと。取付面板厚は最小2 最大5とする。
またはネジ長さ (+7.8, 8) ±2 のセムスBを使用のこと。

NOTE

1. TABLE 1 INDICATES TOLERANCE OF DIMENSIONS WHICH IS NOT SPECIFIED.
2. # : MINIMUM SERVICE CLEARANCE.
3. USE SEMS B SCREWS (M4x12) FOR FIXING THE UNIT. MOUNT BOARD THICKNESS (t): $2 \leq t \leq 5$.
OR SCREW LENGTH SHOULD BE (+7.8)±2 FOR THICKER ONE.

DRAWN	9/Sep/2011	T. YAMASAKI	TITLE	FSV-653
CHECKED	9/Sep/2011	H. MAKI	名称	簡易操作部
APPROVED	13/Sep/2011	Y. NISHIYAMA	外寸図	
SCALE	1/3	質量はケーブル (5m) を含む。 ±0% MASS 1.4 kg MASS INCLUDES CABLE (5m).	NAME	SUB CONTROL UNIT
DWG. No.	C1335-G05-D	REF. No.	10-088-851G-1	OUTLINE DRAWING

表1 TABLE 1

寸法区分 (mm) DIMENSION	公差 (mm) TOLERANCE
$L \leq 50$	± 1.5
$50 < L \leq 100$	± 2.5
$100 < L \leq 500$	± 3

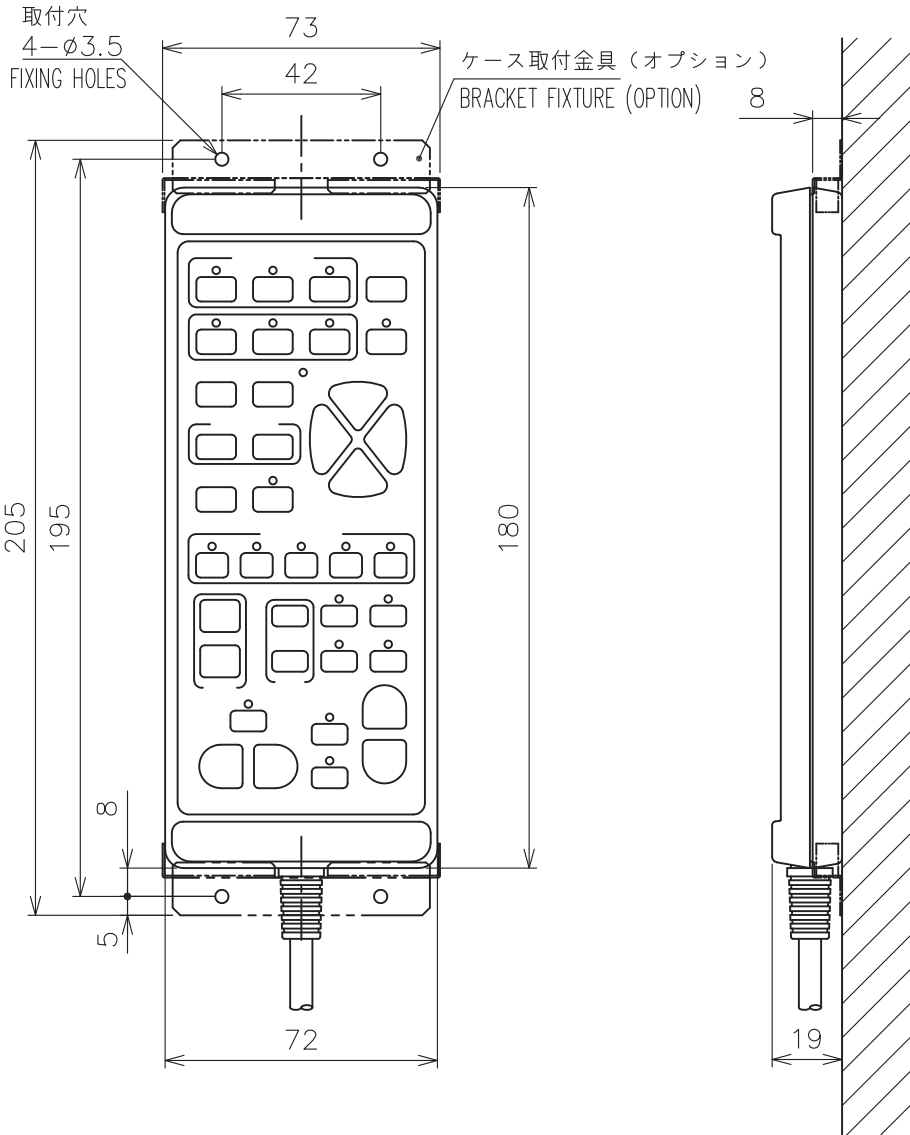

注 記

- 1) 指定外の寸法公差は表 1 による
- 2) 取付用ネジは+バインドタッピン 1 シュ呼び径 3 × 20 を使用のこと

NOTE

1. TABLE 1 INDICATES TOLERANCE OF DIMENSIONS WHICH IS NOT SPECIFIED.
2. USE BINDING TAPPING SCREWS $\phi 3 \times 20$ FOR FIXING THE UNIT.

DRAWN	21/Nov/2013	T.YAMASAKI	TITLE	FSV-2504
CHECKED	25/Nov/2013	H.MAKI	名称	リモコン
APPROVED	27/Nov/2013	H.MAKI		外寸図
SCALE	1/2	MASS 0.68 $\pm 10\%$ kg	質量はケーブル (10m) を含む。 MASS INCLUDES 10m CABLE.	NAME
DWG. No.	C1344-G07- A	REF. No.	10-089-260G- 0	REMOTE CONTROLLER
				OUTLINE DRAWING



表2 TABLE 2

放熱ファン FAN	有 YES	無 NO
質量 (kg±10%) MASS	17.9	16.2

延長箱使用時放熱ファンは延長箱に取り付け
REMOUNT FANS ONTO EXTENSION BOX WHEN AN
EXTENSION BOX IS USED.

表1 TABLE 1

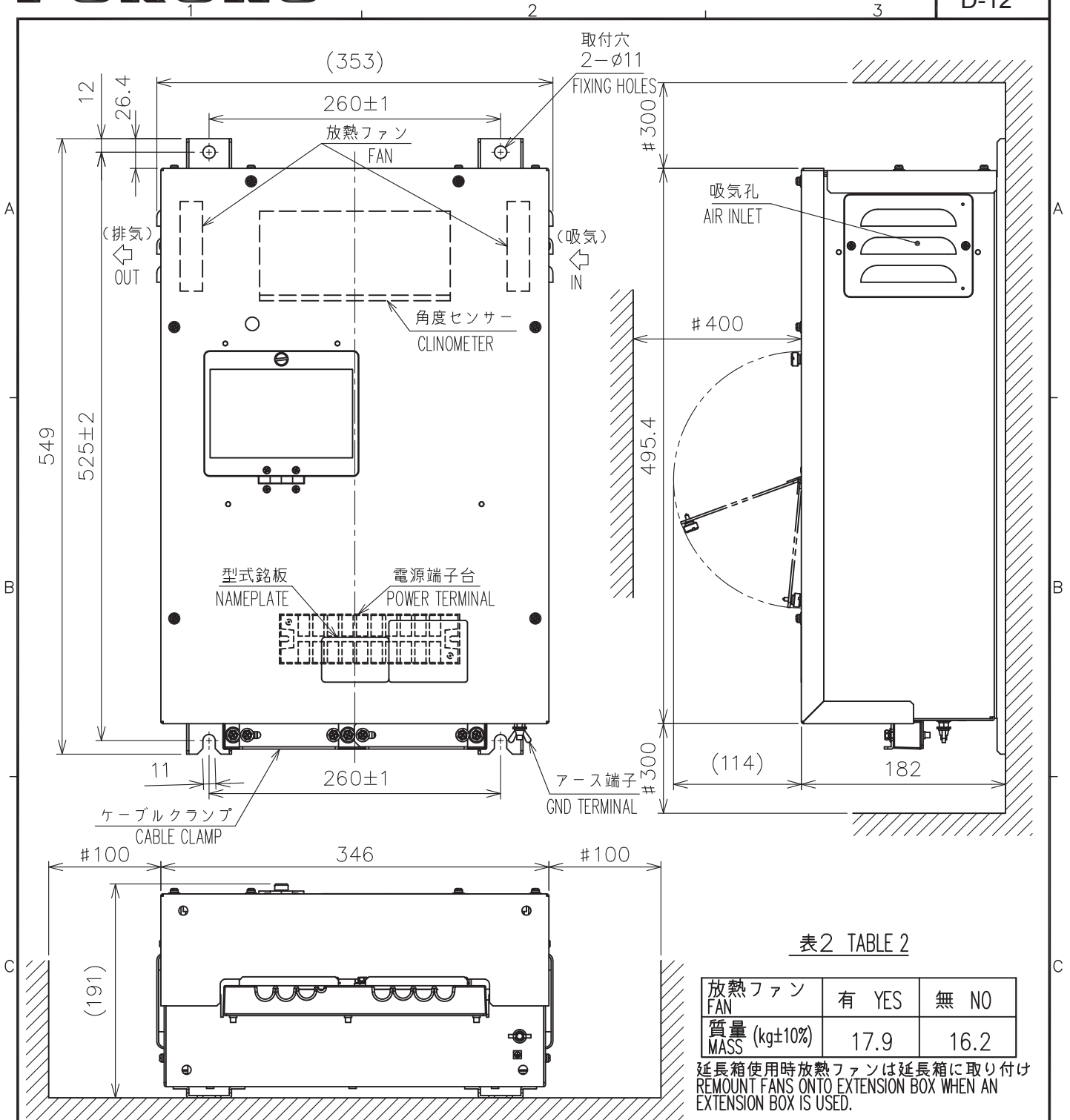
寸法区分 (mm) DIMENSION	公差 (mm) TOLERANCE
L ≤ 50	±1.5
50 < L ≤ 100	±2.5
100 < L ≤ 500	±3
500 < L ≤ 1000	±4

注 記

- 1) 指定外の寸法公差は表1による。
- 2) #印寸法は最小サービス空間寸法とする。
- 3) 取付はM10ボルトを使用のこ。

NOTE

1. TABLE 1 INDICATES TOLERANCE OF DIMENSIONS WHICH IS NOT SPECIFIED.
2. #: MINIMUM SERVICE CLEARANCE.
3. USE M10 BOLTS FOR FIXING THE UNIT.

DRAWN 18/Apr/2014 T.YAMASAKI	TITLE FSV-2530
CHECKED 18/Apr/2014 H.MAKI	名称 上下動制御器 (壁掛装備)
APPROVED 18/Apr/2014 H.MAKI	外寸図
SCALE 1/5	NAME RAISE/LOWER CONTROL BOX (BULKHEAD MOUNT)
DWG. No. C1344-G09-B	REF. No. 10-089-580G-1
MASS 表2参照 SEE TABLE 2	OUTLINE DRAWING

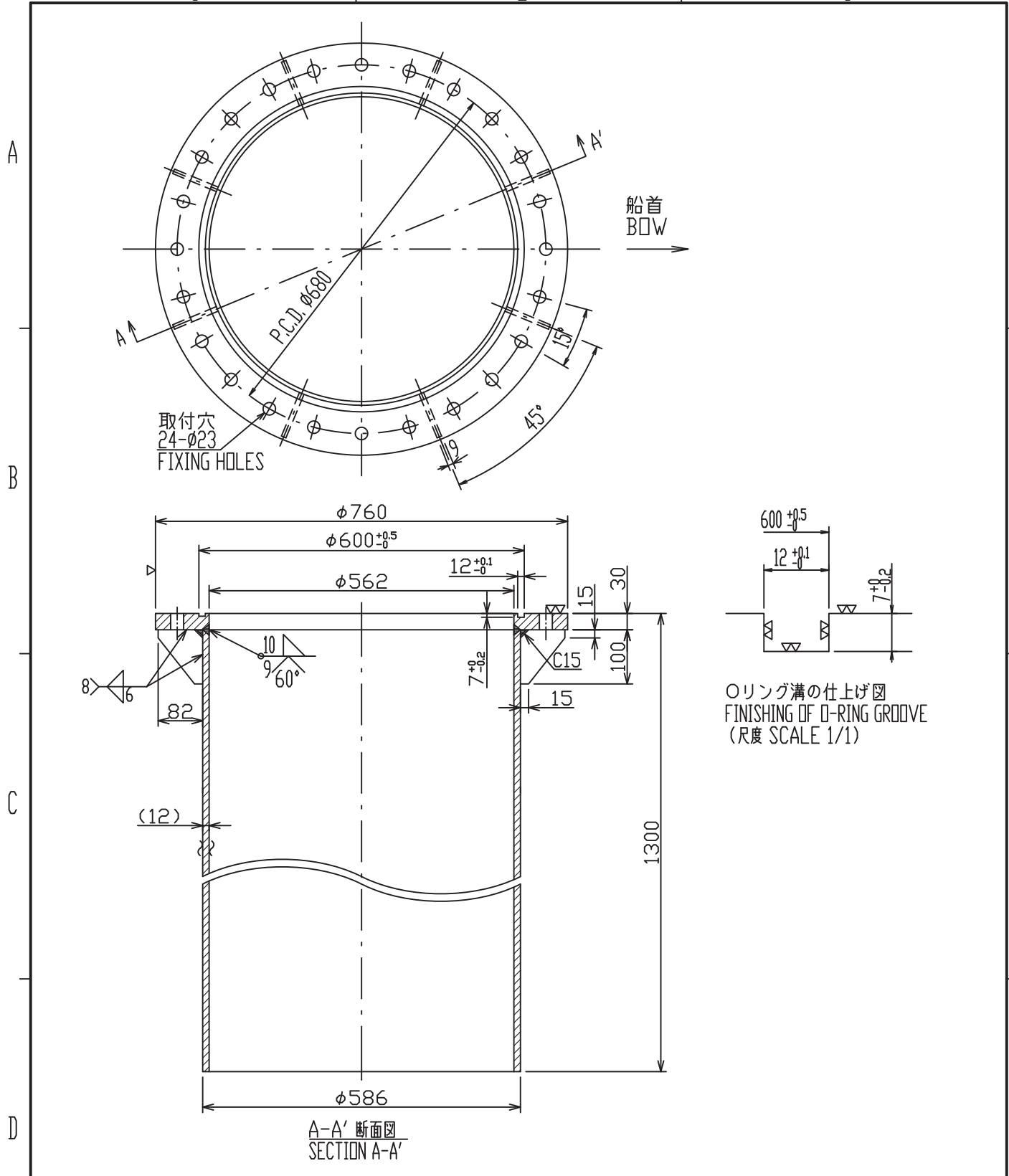

リング溝の仕上げ図
FINISHING OF O-RING GROOVE
(尺度 SCALE 1/1)

注記 1) 装備時24個のボルト穴のうち適当な1個を船首方向に一致させる。
NOTE 1. ONE OF 24 BOLT HOLES SHOULD BE FACED DEAD AHEAD.

DRAWN	11/Nov/2013 T.YAMASAKI	TITLE	10-077-5501
CHECKED	11/Nov/2013 H.MAKI	名称	格納タンク
APPROVED	11/Nov/2013 H.MAKI	FSV-24/25/30/35	外寸図
SCALE	1/10	MASS	260 ±10% kg
DWG. No.	C1318-G16-C	REF. No.	10-077-5501-0
		NAME	RETRACTION TANK OUTLINE DRAWING



表1 TABLE 1

寸法区分 (mm) DIMENSION	公差 (mm) TOLERANCE
L ≤ 50	±1.5
50 < L ≤ 100	±2.5
100 < L ≤ 500	±3
500 < L ≤ 1000	±4

NOTE

1. TABLE 1 INDICATES TOLERANCE OF DIMENSIONS WHICH IS NOT SPECIFIED.
2. # MINIMUM SERVICE CLEARANCE.
3. USE M10 BOLTS FOR FIXING THE UNIT.

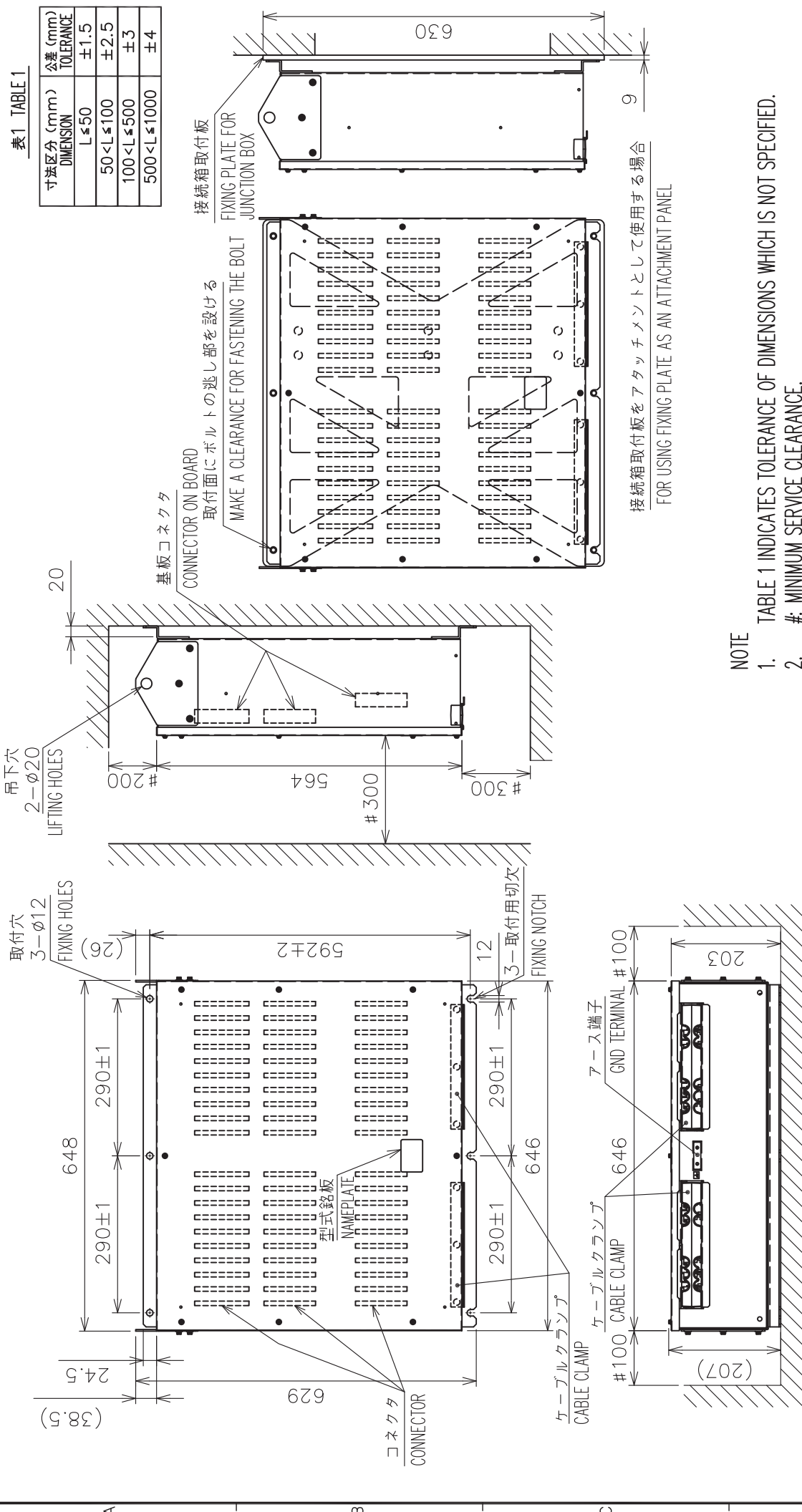
接続箱取付板をアタッチメントとして使用する場合は
FOR USING FIXING PLATE AS AN ATTACHMENT PANEL

DRAWN	22/Apr/2014	I.YAMASAKI	TITLE	FSV-2550
CHECKED	22/Apr/2014	H.MAKI	名称	接続箱 (壁掛装備)
APPROVED	25/Apr/2014	H.MAKI	外寸図	
SCALE	1/10	1/10	NAME	JUNCTION BOX (BULKHEAD MOUNT)
DMC No.	C1344-G11-B	REF.No.	10-089-700G-2	OUTLINE DRAWING

注記

- 1) 指定外の寸法公差は表1による。
- 2) #印寸法は最小サービス空間寸法とする。
- 3) 取付はM10ボルトを使用のこと。

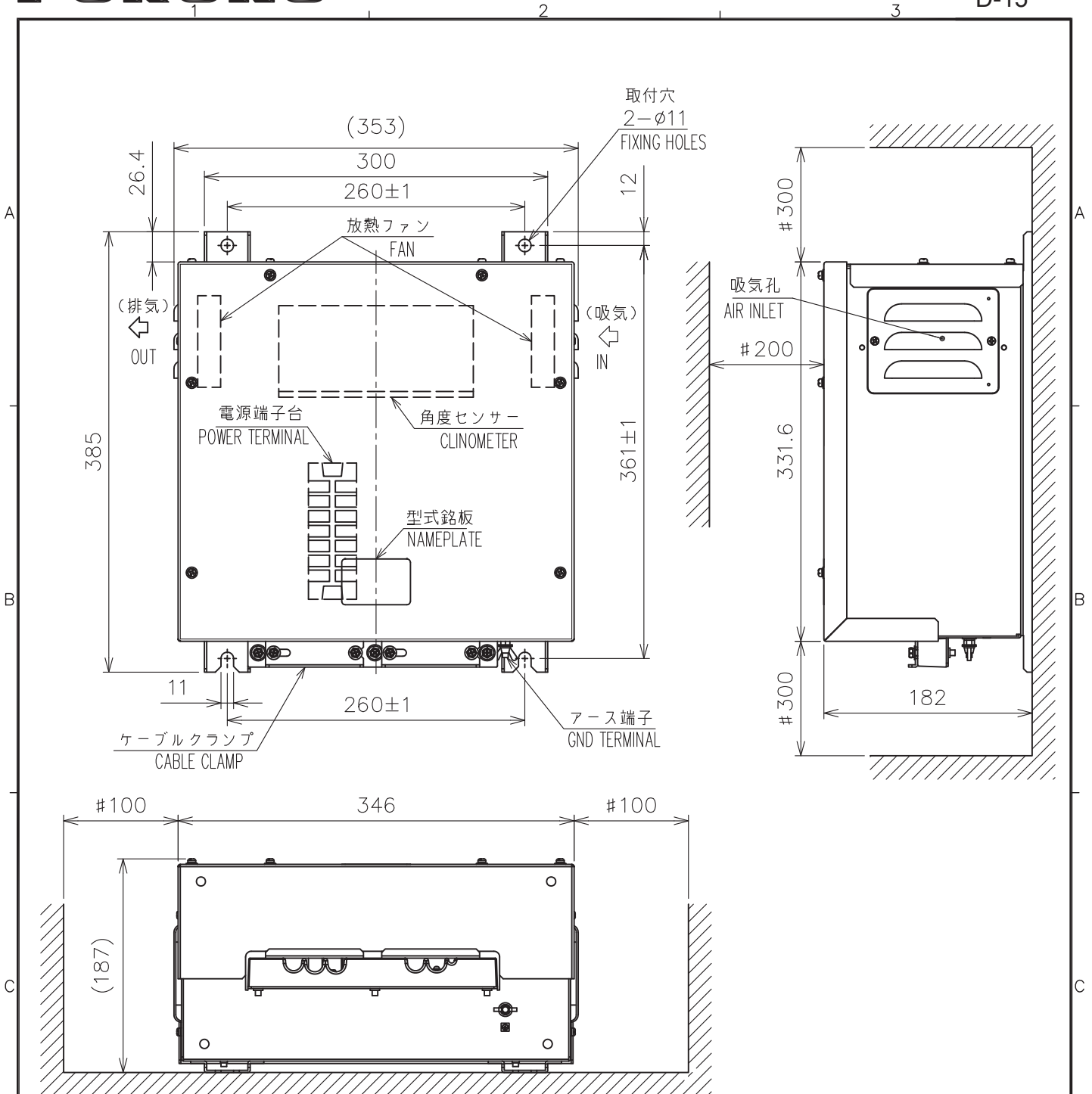

注 記

- 1) 指定外の寸法公差は表 1 による。
- 2) #印寸法は最小サービス空間寸法とする。
- 3) 取付はM10ボルトを使用のこと。

NOTE

1. TABLE 1 INDICATES TOLERANCE OF DIMENSIONS WHICH IS NOT SPECIFIED.
2. #: MINIMUM SERVICE CLEARANCE.
3. USE M10 BOLTS FOR FIXING THE UNIT.

表1 TABLE 1

寸法区分 (mm) DIMENSION	公差 (mm) TOLERANCE
L ≤ 50	±1.5
50 < L ≤ 100	±2.5
100 < L ≤ 500	±3

DRAWN 22/Apr/2014 T.YAMASAKI	TITLE FSV-2560
CHECKED 22/Apr/2014 H.MAKI	名称 制御器延長箱 (壁掛装備)
APPROVED 22/Apr/2014 H.MAKI	外寸図
SCALE 1/5	NAME CONTROL BOX EXTENSION BOX (BULKHEAD MOUNT)
MASS 9.2 ±10% kg	OUTLINE DRAWING
DWG. No. C1344-G10-B	REF. No. 10-089-590G-2

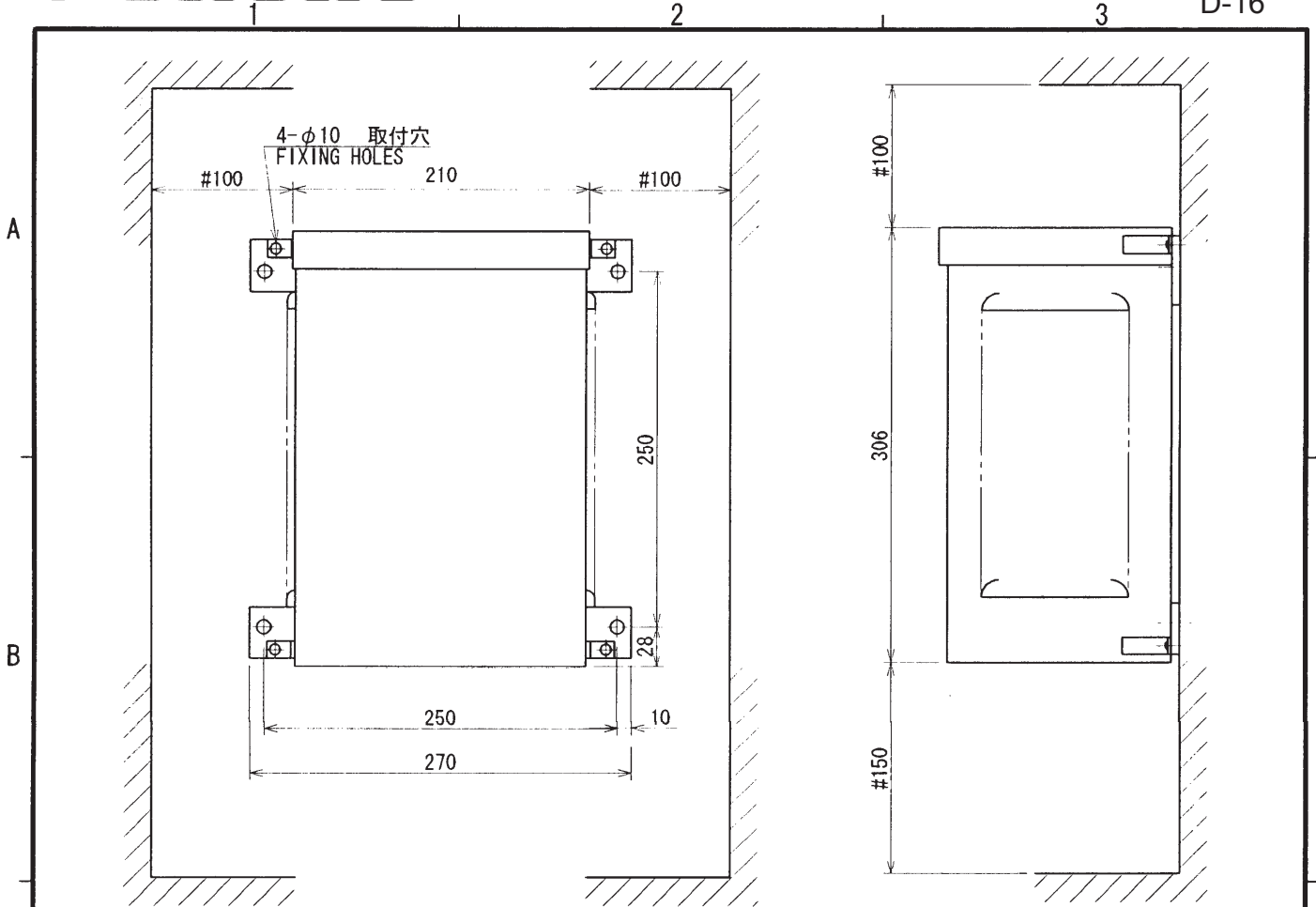

A

B

C

D

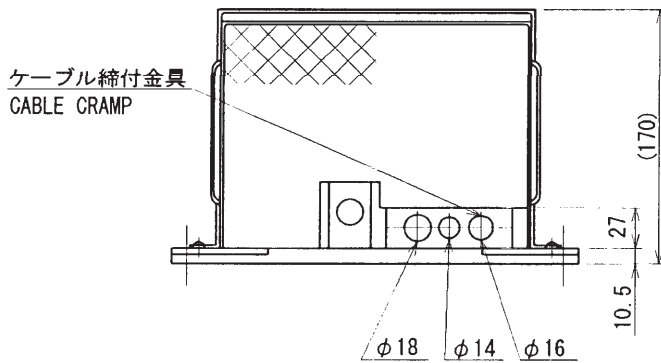

NOTE 1. # : 推奨サービス空間
RECOMMENDED SERVICE CLEARANCE.

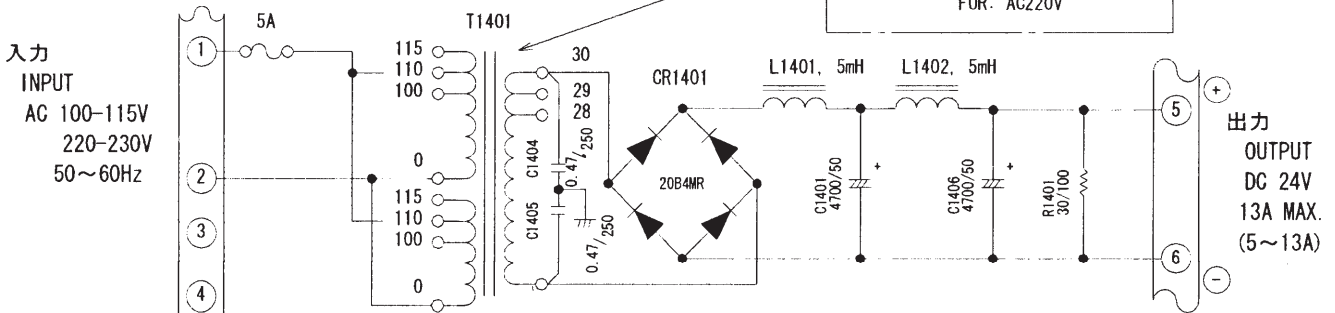
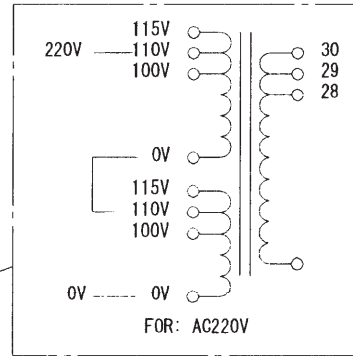

注記 AC220V入力に対しては T1401の一次巻線を直列に接続する。
NOTE FOR 220V AC INPUT, CONNECT T1401 PRIMARY WINDINGS IN SERIES.

DRAWN	Aug 16 '00 T.YAMASAKI
CHECKED	Aug 17 '00 Y.Kim
APPROVED	Aug 17 '00 Y.Kim
SCALE	1/5
MASS	±10% 17 kg
DWG. No.	C3002-002- N

TITLE	RU-1746B-2
名称	整流器
	外寸図
NAME	RECTIFIER UNIT
	OUTLINE DRAWING



表1 TABLE 1

寸法区分(mm) DIMENSION	公差(mm) TOLERANCE
0 < L ≤ 50	±1.5
50 < L ≤ 100	±2.5
100 < L ≤ 500	±3

注記
アース端子
GND TERMINAL
EYE-BOLT
2-M10 アイボルト

- 1) 指定なき寸法公差は表1による。
- 2) #印寸法は最小サービス空間寸法とする。
- 3) 取付にはM10ボルトを使用のこと。

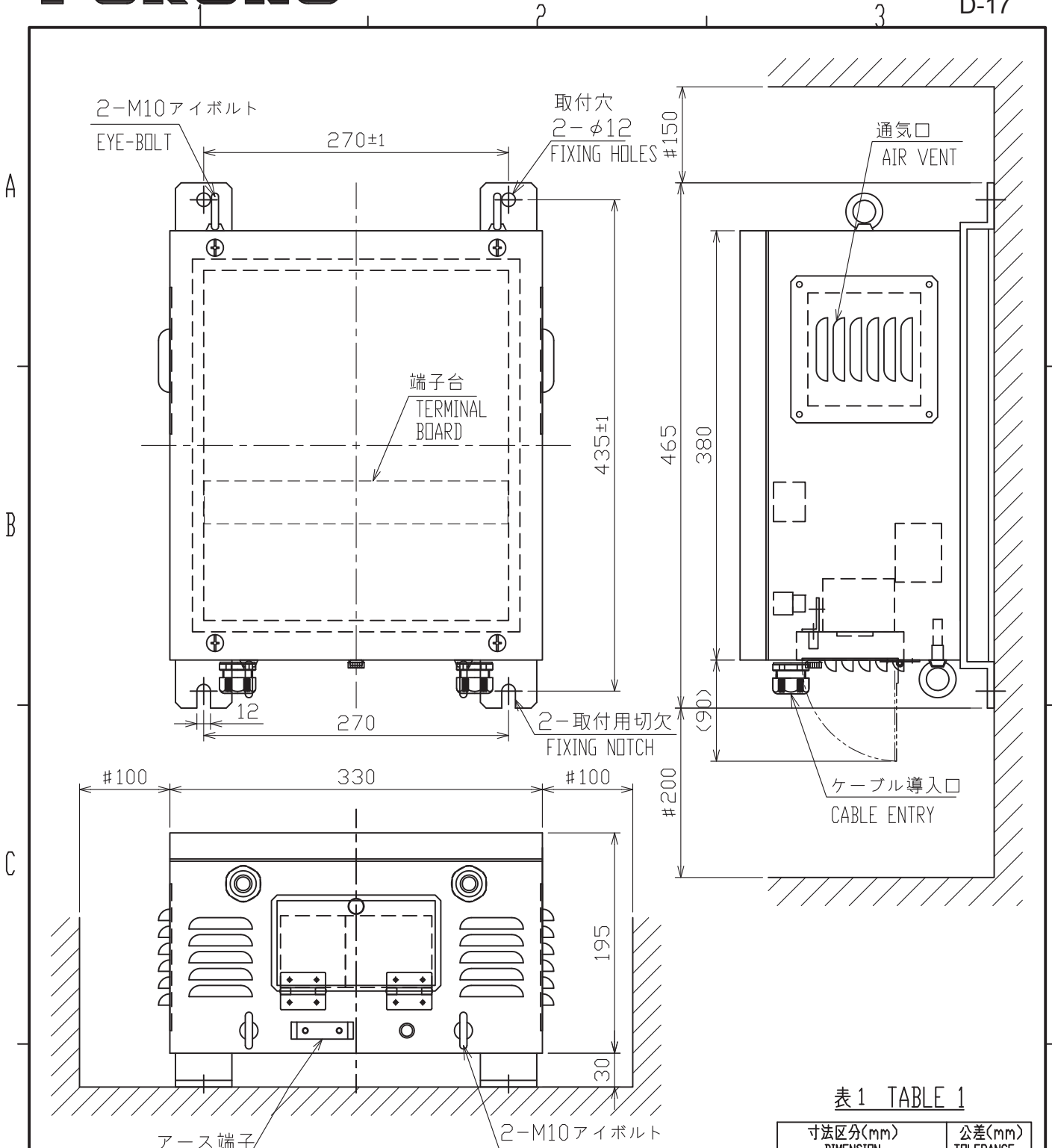
NOTE

1. TABLE 1 INDICATES TOLERANCE OF DIMENSIONS WHICH IS NOT SPECIFIED.
2. #: MINIMUM SERVICE CLEARANCE.
3. USE M10 BOLTS FOR FIXING THE UNIT.

DRAWN 27/Mar/2014 T.YAMASAKI		TITLE FSV-252
CHECKED 27/Mar/2014 H.MAKI		名称 電源装置(壁掛/卓上装備)
APPROVED 27/Mar/2014 H.MAKI	FSV-25/28W	外寸図
SCALE 1/5	MASS 37.5±2 kg	NAME POWER SUPPLY UNIT (BULKHEAD/TABLETOP MOUNT)
DWG. No. C1344-G04- B	REF. No. TR-K-0164	OUTLINE DRAWING

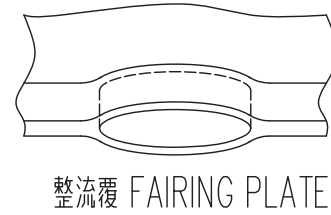
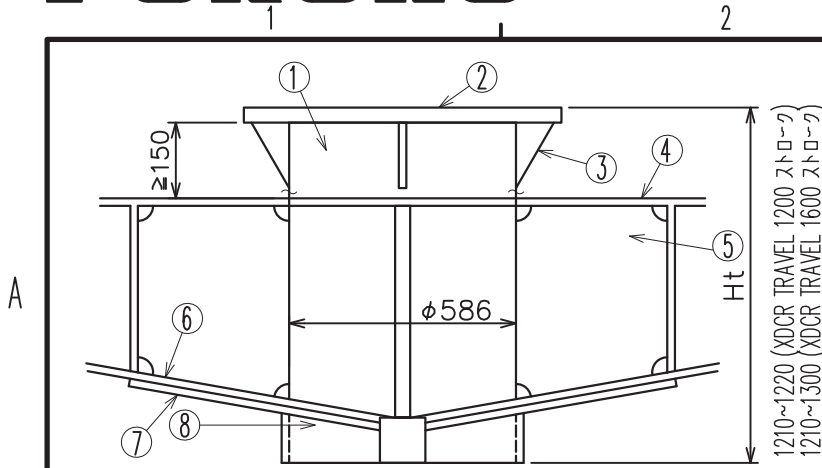

装備手順

1. 次の点に注意して、格納タンクを船底板に連続スミ肉溶接する。
 - * タンクのフランジ面が標準走航時に水平になること。
 - * フランジ面のボルト穴の中心が船首方向になること。
 - * 送受波器を突出させたときに送受波ビームがキールで遮られないように、フランジ面のキールよりの高さ“Ht”を図示の範囲内にすること。
(標準支給長1300mm)
2. 格納タンクの周囲にダブリング⑦および整流覆⑧を取り付ける。
ダブリングと整流覆には、船底板と同じ材質・肉厚のものを使用すること。
3. タンク周囲と隔壁⑤を溶接する。
4. 上下装置本体を格納タンクにボルト締めするのに必要なスペースとしてフランジ面の位置を二重船底板より150mm以上離す。

INSTALLATION METHOD OF RETRACTION TANK

1. Install tank to hull plate with fillet welding taking the following points into account;
 - * Flange face is exactly horizontal at normal ship's trim.
 - * One of 24 bolt holes on flange is faced dead ahead.
 - * Allow height of flange face from keel bottom "Ht" mentioned in the drawings, otherwise transducer beam is blocked by the keel, when transducer is fully lowered.
(The length of tank: 1300mm standard)
2. Fit doubling plate ⑦ and fairing plate ⑧ around the tank on hull plate.
Use same material and thickness of doubling and fairing plate as hull plate.
3. Weld the tank into bulkhead ⑤ around the tank.
4. Allow clearance of more than 150 mm below the flange face for easy bolting.

8	整流覆 FAIRING PLATE				
7	ダブリング DOUBLING				
6	船底板 HULL PLATE				
5	油槽隔壁 BULKHEAD				
4	二重船底板 INNER HULL PLATE				
3	補強リブ REINFORCEMENT RIB				
2	タンクフランジ TANK FLANGE				
1	格納タンク RETRACTION TANK				
品番 ITEM	品名 NAME	材質 MATERIAL	数量 QTY	図番 DWG. NO	摘要 REMARKS

DRAWN 19/Jun/2014 I. YAMASAKI

CHECKED 19/Jun/2014 H. MAKI

APPROVED 19/Jun/2014 H. MAKI

SCALE MASS kg

DWG. No. C1344-Y01-B

FSV-25

REF. No.

TITLE 10-026-3011

名称 格納タンク (鋼船用)

装備要領

NAME RETRACTION TANK (FOR STEEL HULL)

INSTALLATION PROCEDURE

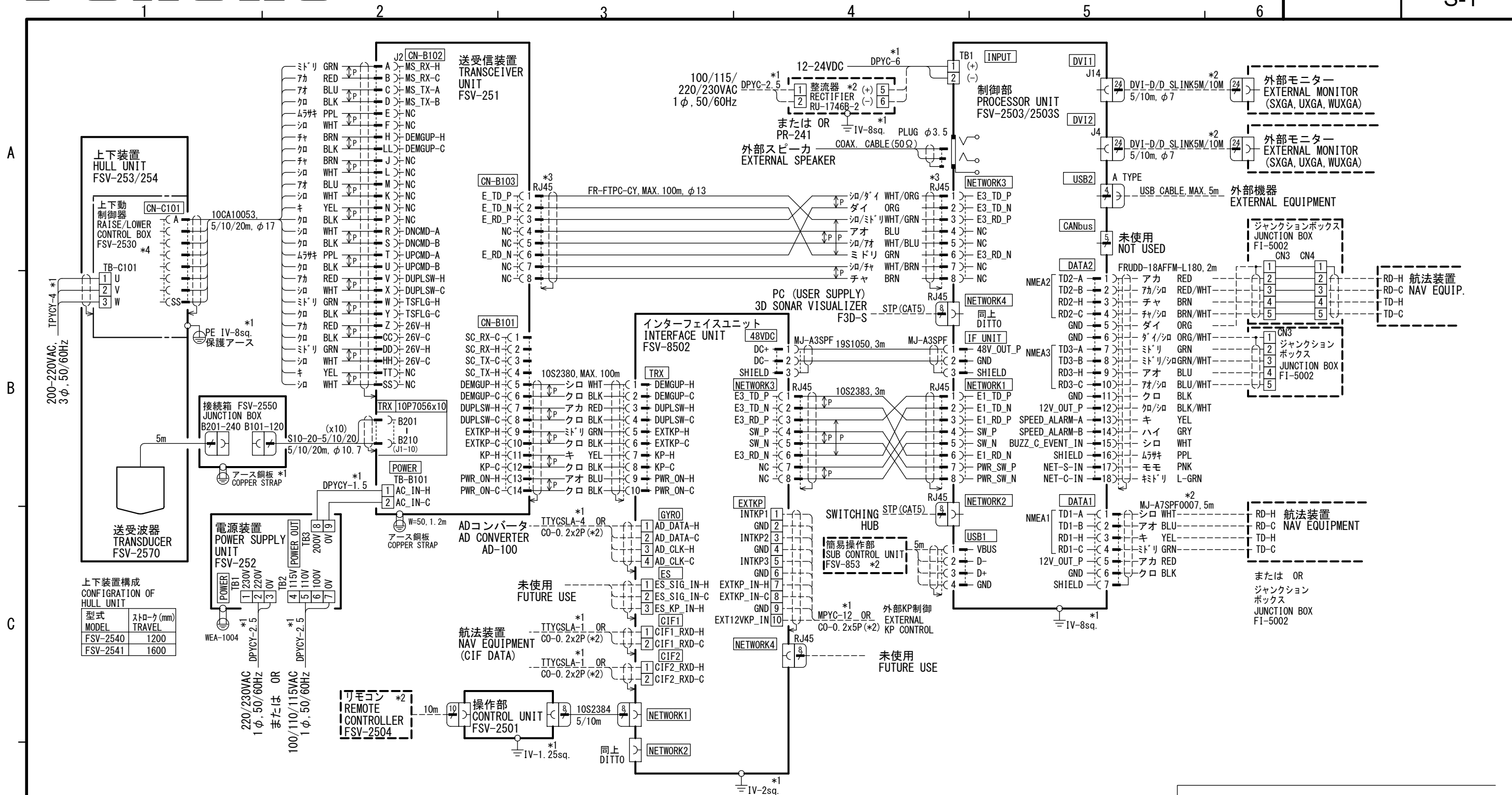

注記
 * 1) 造船所手配。
 * 2) オプション。
 * 3) コネクタは現地取付。
 * 4) 制御器延長箱 (オプション) 使用で上下動制御器を上下装置から5m離して取付可能。

NOTE
 *1: SHIPYARD SUPPLY.
 *2: OPTION.
 *3: FIT CONNECTOR AT LOCAL.
 *4: CONTROL BOX EXTENSION BOX (OPTION) MAY EXTEND TO 5m BETWEEN RAISE/LOWER CONTROL BOX AND HULL UNIT.

CO-0. 2x2P: CO-SPEVV-SB-C 0. 2x2P, φ 10. 5
 CO-0. 2x5P: CO-SPEVV-SB-C 0. 2x5P, φ 13. 5

DRAWN	16/Feb/2021 T. YAMASAKI	TITLE	FSV-25/25S
CHECKED	16/Feb/2021 H. MAKI	名称	カラーキャニングソナー
APPROVED	24/Feb/2021 H. MAKI		相互結線図
SCALE	MASS kg	NAME	COLOR SCANNING SONAR
DWG No.	G1344-C01-L	REF. No.	10-089-0201-2
		INTERCONNECTION DIAGRAM	

A

B

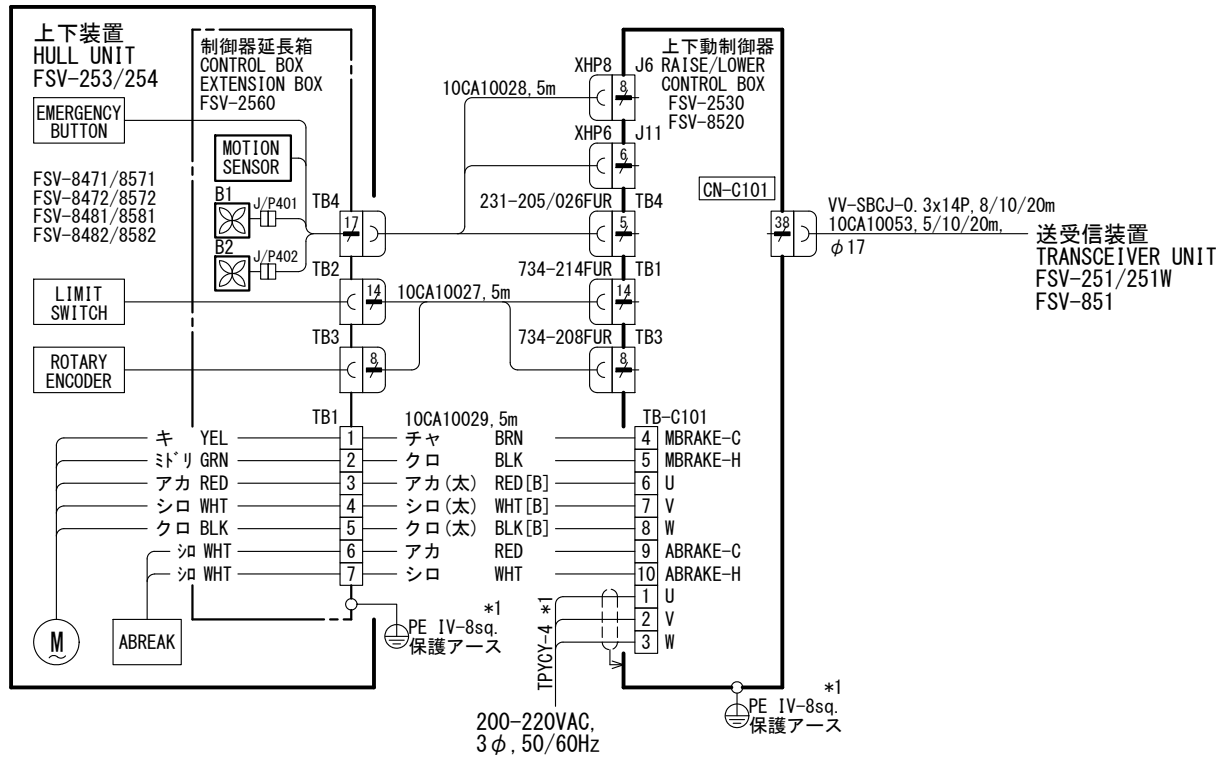

C

D

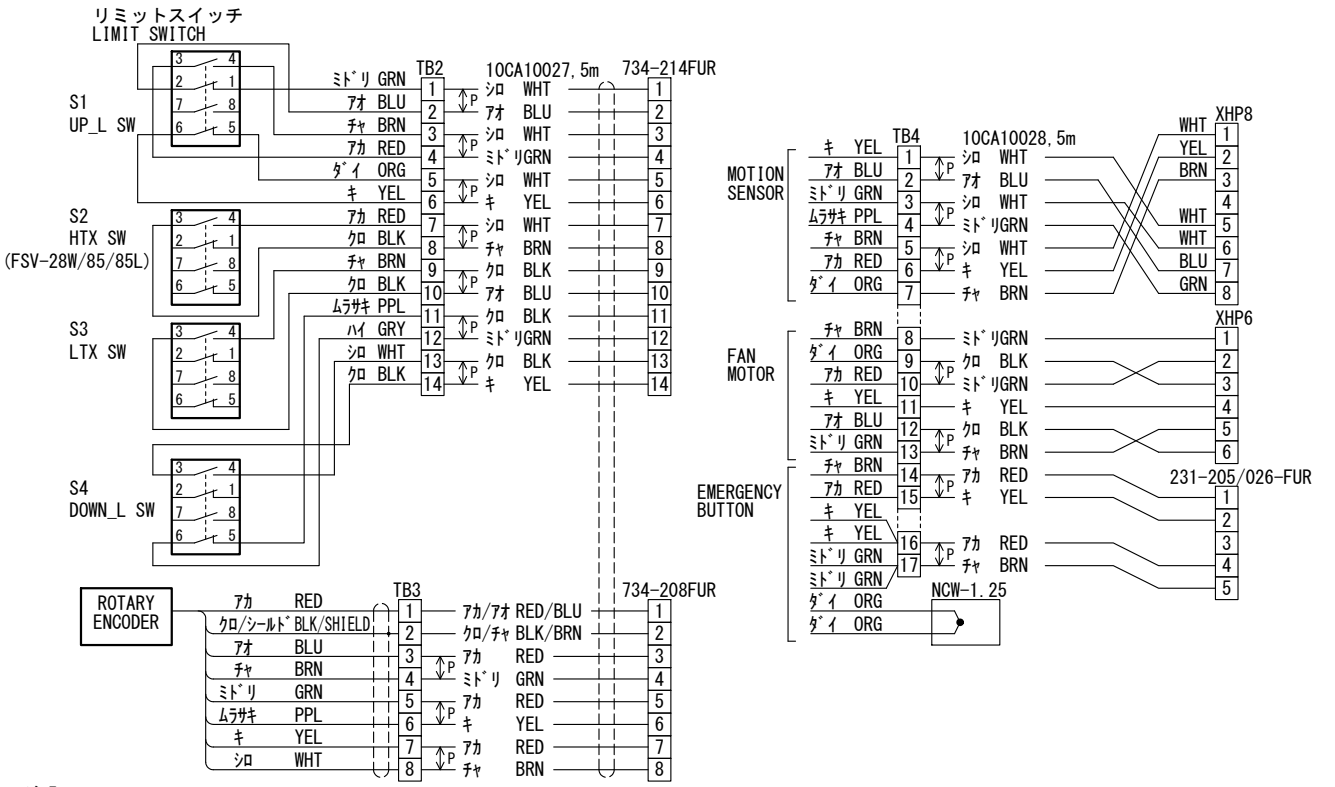

注記
* 1) 造船所手配。

NOTE
*1: SHIPYARD SUPPLY.

DRAWN 27/Feb/2019 T. YAMASAKI	TITLE FSV-2560
CHECKED 27/Feb/2019 H. MAKI	名称 制御器延長箱
APPROVED 28/Feb/2019 H. MAKI	相互結線図
SCALE MASS kg	NAME CONTROL BOX EXTENSION BOX
DWG. No. C1344-C02- G	REF. No. 10-089-5001-4
INTERCONNECTION DIAGRAM	