

Installation Manual

Color Scanning Sonar

Model FSV-85-MARK-2

SAFETY INSTRUCTIONS	i	3.10 How to Configure the Own Ship Mark	3-10
SYSTEM CONFIGURATION	iii	3.11 Others Menu	3-11
EQUIPMENT LISTS.....	v		
1. HOW TO INSTALL THE SYSTEM ..	1-1	APPENDIX 1 JIS CABLE GUIDE	AP-1
1.1 Hull Unit	1-1	APPENDIX 2 INSTALLATION	
1.2 Processor Unit	1-11	CHECK LIST	AP-2
1.3 Control Unit.....	1-12		
1.4 Transceiver Unit.....	1-17	PACKING LISTS	A-1
1.5 Raise/Lower Control Box	1-18	OUTLINE DRAWINGS	D-1
1.6 Control Box Extension Box	1-19	INTERCONNECTION DIAGRAMS	S-1
1.7 Attachment Kit (option)	1-19		
1.8 How to Fill the Soundome with Antifreeze.....	1-21		
1.9 FRP Tank (option).....	1-22		
1.10 Sub Control Unit (option)	1-24		
2. WIRING.....	2-1		
2.1 How to Use the Crimping Tool, Pin Extractor	2-1		
2.2 How to Connect Units	2-2		
2.3 Processor Unit	2-5		
2.4 Control Unit.....	2-11		
2.5 Transceiver Unit.....	2-12		
2.6 Raise/Lower Control Box	2-16		
2.7 Control Box Extension Box	2-18		
3. ADJUSTMENTS AND CHECKS	3-1		
3.1 How to Access the System Menu	3-1		
3.2 How to Change the Displayed Language	3-1		
3.3 Selecting Monitor Resolution	3-2		
3.4 How to Set Up for Two Monitors	3-3		
3.5 How to Set Up a Vertical Monitor.....	3-4		
3.6 How to Change the Frequency Setting.....	3-4		
3.7 How to Register the Transducer Position	3-5		
3.8 How to Check the Hull Unit.....	3-6		
3.9 How to Adjust the Heading	3-9		

**FURUNO ELECTRIC CO., LTD.**www.furuno.com

All brand and product names are trademarks, registered trademarks or service marks of their respective holders.

ECF

(Elemental Chlorine Free)

The paper used in this manual
is elemental chlorine free.

FURUNO ELECTRIC CO., LTD.

9-52 Ashihara-cho,
Nishinomiya, 662-8580, JAPAN

• FURUNO Authorized Distributor/Dealer

All rights reserved. Printed in Japan

A : JUL. 2021

Pub. No. IME-13670-A

(TEHI) FSV-85-MARK-2-70/80





0 0 0 1 9 8 9 0 4 1 0



SAFETY INSTRUCTIONS

The installer must read the safety instructions before attempting to install the equipment.

 DANGER	Indicates a potentially hazardous situation which, if not avoided, will result in death or serious injury.
 WARNING	Indicates a potentially hazardous situation which, if not avoided, could result in death or serious injury.
 CAUTION	Indicates a potentially hazardous situation which, if not avoided, may result in minor or moderate injury.

 Warning, Caution	 Prohibitive Action	 Mandatory Action
--	--	--

 **DANGER**

 **Keep away from raise/lower shaft in hull unit when it is moving.**

Gears will cause serious injury. In case of an emergency, press the **EMERGENCY STOP** button to stop the raising or lowering of the transducer.

 **Confirm that there is no person below the transducer before raising or lowering the transducer.**

 **WARNING**

 **Be sure no water leaks in at the hull unit.**

Water leakage can sink the vessel. Also confirm that the transducer will not loosen by ship's vibration. The installer of the equipment is solely responsible for the proper installation of the equipment. FURUNO will assume no responsibility for any damage associated with improper installation.

 **WARNING**

 **Do not open the equipment unless totally familiar with electrical circuits and service manual.**

High voltage exists inside the equipment, and a residual charge remains in capacitors several minutes after the power is turned off. Improper handling can result in electrical shock.

 **Turn off the power at the mains switchboard before beginning the installation.**

Fire, electrical shock or serious injury can result if the power is left on or is applied while the equipment is being installed.

 **Do not install the equipment where it may get wet from rain or water splash.**

Water can cause fire or electrical shock, or damage the equipment.

 **If a steel tank is installed on a wooden or FRP vessel, take appropriate measures to prevent electrolytic corrosion.**

Electrolytic corrosion can damage the hull.

 **Install the specified transducer tank in accordance with the installation instructions. If a different tank is to be installed the shipyard is solely responsible for its installation, and it should be installed so the hull will not be damaged if an object strikes the tank.**

The tank or hull may be damaged if the tank strikes an object.

 **Be sure to power each unit with proper voltage.**

Connection of an improper power supply can cause fire or damage the equipment.

 **CAUTION**

WORKING WITH THE SONAR OIL
Precautions

- Keep the oil away from eyes. Wear protective glasses when working with the oil. The oil can cause inflammation of the eyes.
- Do not touch the oil. Wear protective gloves when working with the oil. The oil can cause inflammation of the skin.
- Do not ingest the oil. Diarrhea or vomiting can result.
- Keep the oil out of reach of children.
- For further details, see the material safety data sheet (MSDS).

 **Emergency**

- If the oil enters eyes, flush with clean water for about 15 min. Consult a physician.
- If the oil contacts skin, wash with soap and water.
- If the oil is ingested, see a physician immediately.
- Keep the oil out of reach of children.
- For other information, see the safety data sheet (SDS).

Disposal of oil and its container

- Dispose of oil and its container in accordance with local regulations. For further details, contact the place of purchase.

Storage

- Seal container to keep out foreign materials. Store in dark place.

 **CAUTION**

 **Maximum speed while the transducer is projected or being raised or lowered is as below, to prevent damage to the transducer.**

Projected	Raising/ Lowering
18 kn	15 kn

 **Ground the equipment to prevent electrical shock and mutual interference.**

 **Observe the following compass safe distances to prevent magnetic compass deviation:**

Unit	Standard compass	Steering compass
Processor Unit	2.15 m	1.35 m
Control Unit	0.30 m	0.30 m
Sub Control Unit	0.90 m	0.55 m
Remote Controller	0.30 m	0.30 m

SYSTEM CONFIGURATION

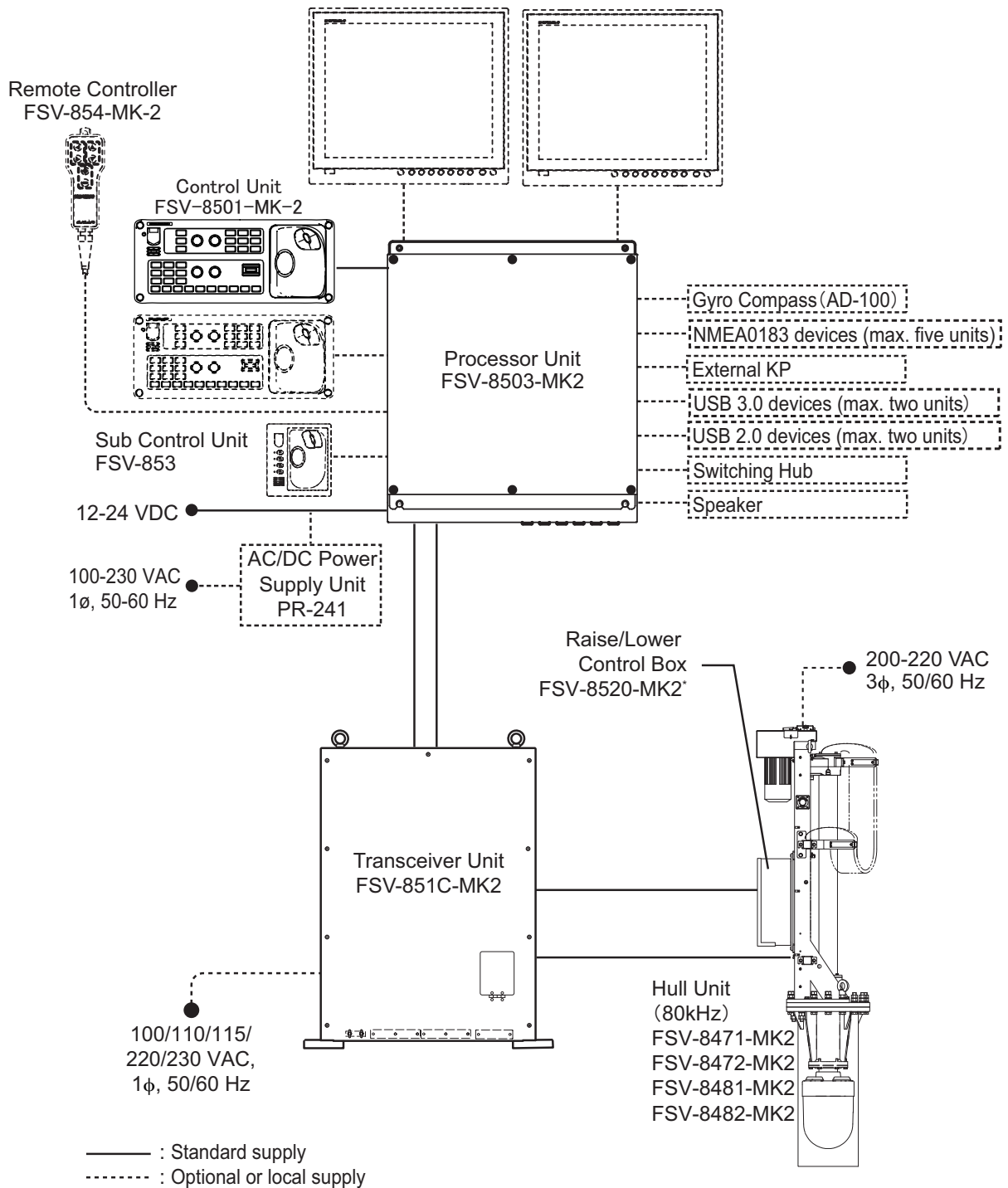

*: Use the optional Control Box Extension Box (FSV-2560) to extend the distance between the raise/lower control box and the hull unit.

Equipment identification tables

Transducer

	FSV-8422-MK2	FSV-8423-MK2
Frequency	80 kHz	
Dome	Yes (thickness: 8mm)	No
Nameplate	Yes (Unit type and serial no.)	
Color of binding tape	Yellow	
Cable fabrication, label	Yes (Unit name and serial no.)	
Color of unit	Black	
Dome label	Yes	-
Dome (flange) stamping	No	-

EQUIPMENT LISTS

Standard supply

Name	Type	Code No.	Qty	Remarks
Control Unit	FSV-8501-MK2	-	1	With 10 m cable
Processor Unit	FSV-8503-MK2	-	1	
Transceiver	FSV-851C-MK2	-	1	
Hull Unit	FSV-8471-MK2	-	1	800 travel, 80 kHz with dome
	FSV-8472-MK2	-		800 travel, 80 kHz less dome
	FSV-8481-MK2	-		1100 travel, 80 kHz with dome
	FSV-8482-MK2	-		1100 travel, 80 kHz less dome
Installation Materials	CP10-06000	000-067-071	1	
	CP10-09600	000-036-274	1	For Control Unit
	CP10-09700	000-036-275	1	For Processor Unit
	CP10-07011	001-005-660	1	For Transceiver Unit
Spare Parts	SP26-00301	001-080-860	1	For Processor Unit
	SP10-03101	007-008-530	1	For Transceiver Unit
	SP10-04201	001-269-280	1	For Hull Unit

Optional supply

Name	Type	Code No.	Remarks	
Control Unit	FSV-8501-MK2	-	With 10 m cable	
Remote Controller	FSV-854-MK2	-	Inst. Mat. CP10-07401	
Sub Control Unit	FSV-853	-		
Control Box Extension Box	FSV-2560	-		
AC/DC Power Supply Unit	PR-241	-		
Speaker	SEM-21Q	-		
Retraction Tank	OP10-28	000-067-177	Steel	
	OP10-29	000-067-178	FRP, includes liquid gasket	
		000-034-852	FRP, without liquid gasket	
Attachment Kit	OP10-30	000-067-179		
Ferrite Core	OP86-11	001-594-450	For PR-241	
5-Pair Cable	10S2380 *10M*	001-196-330-10	For between the processor unit and the transceiver	10 m
	10S2380 *20M*	001-196-340-10		20 m
	10S2380 *30M*	001-196-350-10		30 m
	10S2380 *40M*	001-196-360-10		40 m
	10S2380 *50M*	001-196-370-10		50 m
	10S2380 *60M*	001-196-380-10		60 m
	10S2380 *100M*	001-196-390-10		100 m
Cable Assembly	HDMI-TO-DVI-L=5.3M	001-407-180	DVI-HDMI cable	5.3 m
	HDMI-TO-DVI-L=10.3M	001-407-170		10.3 m
Installation Materials	CP10-10100	000-036-244	LAN cable	10 m
	CP10-10110	000-036-245		15 m
	CP10-10120	000-036-246		30 m
	CP10-10130	000-036-247		40 m
	CP10-10140	000-036-248		50 m
	CP10-10150	000-036-722		100 m
Flushmount Kit	FP03-09870	008-535-630		

1. HOW TO INSTALL THE SYSTEM

1.1 Hull Unit

Note 1: The control box on the hull unit contains an inertial measurement unit. Handle the hull unit carefully.

Note 2: Handle the transducer carefully. Rough handling will damage its sensitive components.

1.1.1 Installation considerations

Decide the location of the hull unit through consultation with the dockyard and ship owner. When deciding the location, the following points should be taken into account.

- Select an area where propeller noise, cruising noise, air bubbles and interference from turbulence are at a minimum. Generally, the point at $1/3$ to $1/2$ of the ship's length from the bow on or near the keel is optimum. On-the-keel installation is advantageous for minimizing oil consumption in comparison with off-the-keel. If the hull unit can not be installed on the keel, the center of the retraction tank should be within 600 mm from the keel to prevent a rolling effect. For large ship with deep draft, the hull unit can be installed at the bow.

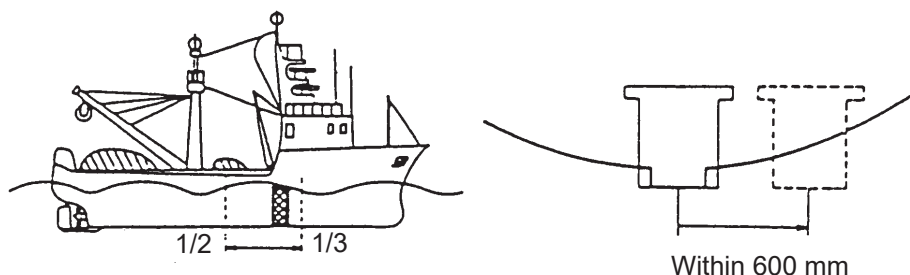

- Select a place where the hull bottom is flat and the draft is sufficiently deep. Normally, the transducer should protrude at least 500 mm beyond the keel to minimize the effect of air foam and bubbles.
- Select a place where interference from other transducers is minimal. The hull unit should be at least 2.5 m away from the transducers of other equipment.
- No obstacle should be in the fore direction since it causes a shadow zone and aerated water, resulting in poor sonar performance.
- The physical distance between the hull unit and the transceiver unit should be no more than 5 m.
- The space shown in the figure on the next page is required around the hull unit for wiring and maintenance.

1. HOW TO INSTALL THE SYSTEM

- If the ambient temperature around the unit will be below 0°C, provide the sonar compartment with a heater to keep the temperature above 0°C.

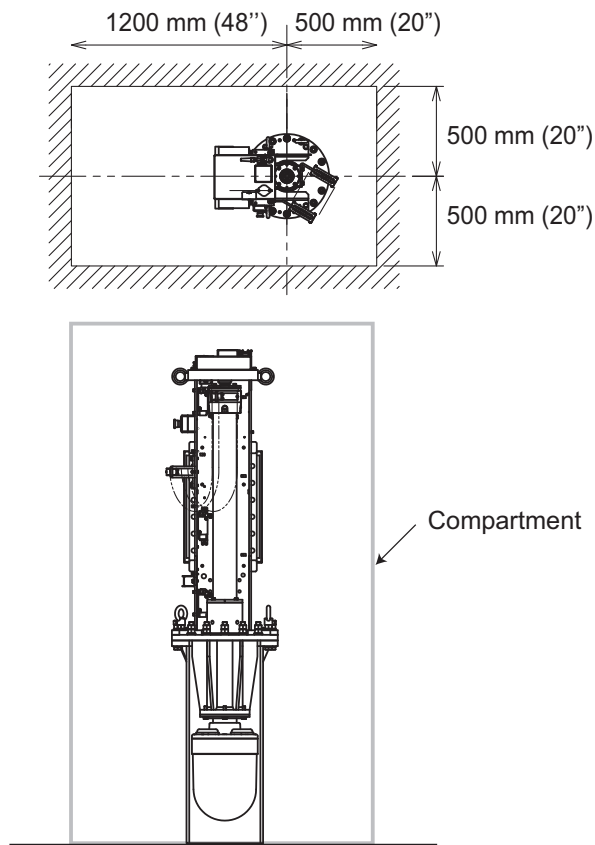

Note: After you mount the hull unit, be sure to install anti-vibration stays, referring to page 1-5.

1.1.2 Guideline for how to shorten the retraction tank

Shorten the tank as necessary so that the transducer positions well below the keel when it is fully lowered. The following table provides guidelines for shortening the tank. Refer also to the retraction tank installation drawing at the back of this manual.

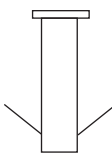
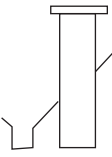
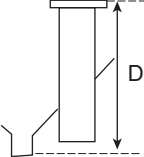
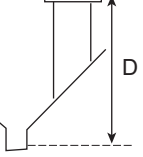
Installation Method				
Stroke				
800 mm stroke	Cut 0-50 mm from the end.	Same as left.	Cut 0-50 mm from the end. Note that the length "D" must be less than 1000 mm.	Same as left.
1100 mm stroke	Cut 0-50 mm from the end.	Same as left.	Cut 0-50 mm from the end. Note that the length "D" must be less than 1200 mm.	Same as left.

Note 1: Adjust the position for the TX limit switch, according the retraction tank length. For how to adjust the position for the TX limit switch, see section 1.1.4.

Note 2: When maximum length is removed and "D" is minimum, the effect of air foam is minimized because the transducer fully protrudes in water.

Guidelines for installation of the retraction tank

- If the keel plate on the inside of the hull is not adequate for installing the retraction tank, install a secondary keel plate.
- Install the retraction tank where the keel plate and hull frame intersect.
- If there is no suitable location where the hull frame and keel intersect, install suitable "T" shaped reinforcement ribs, then weld the base of the frame to the reinforcement ribs and the sides of the reinforcement ribs to the hull walls or other nearby reinforcement ribs. The reinforcement ribs should be secured in the fore, aft, port and starboard directions.
- Install the reinforcement ribs as near as possible to the top of the retraction tank, allowing 150 to 200 mm space for tightening of nuts and bolts.
- Fit a doubling plate (a plate added to another to give extra strength or stiffness) to the location where the retraction tank is welded to the hull bottom. While it is recommended that both sides attach to the hull, consult with the installer regarding length and diameter.

1. HOW TO INSTALL THE SYSTEM

- The thickness for doubling plates and reinforcement ribs is 12 mm minimum.

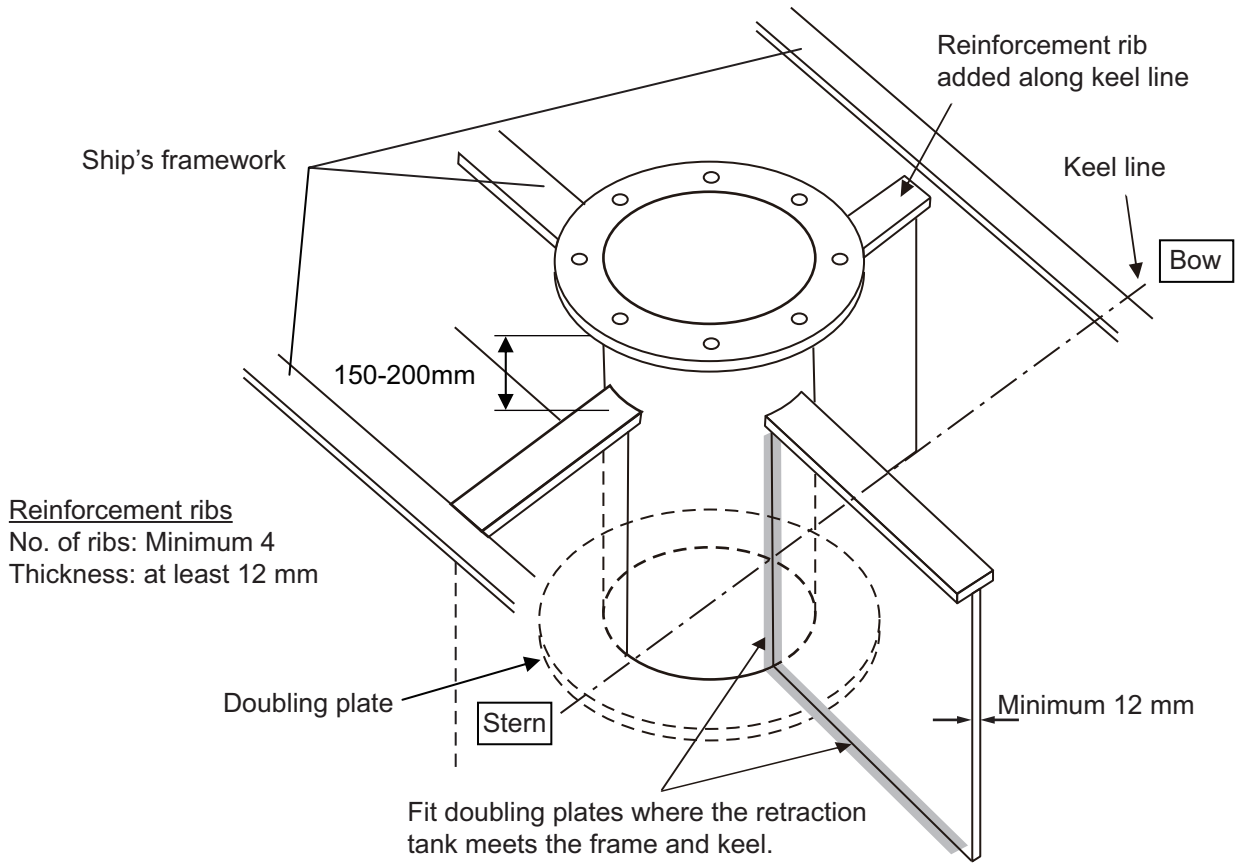

1.1.3 How to install the hull unit on the retraction tank

Weld the retraction tank and allow sufficient time for cooling. Install the hull unit as follows:

Prepare the materials and tools as shown below.

Name	Remarks
Screw wrench	M20 (opposite side 30 mm)
Ethyl alcohol	99.5%
Waste cloths	
Lithium grease	For O-ring and drive shaft Common lithium grease (the equivalent of Daphne Grease MP #2 (IDEMITSU KOSAN CO.,LTD))
Molytone grease	For gear and bearing Molytone grease #2 (by SUMICO LUBRICANT CO., LTD)

1. Clean the flange and O-ring groove of the retraction tank (welded to hull). Use waste cloths moistened with ethyl alcohol.
2. Coat the O-ring and O-ring groove with lithium grease, then place the O-ring in its groove on the tank flange.
3. Orient the hull unit so that the bow mark (inscribed on its flange) points toward the ship's bow.
Note: If the bow mark on the hull unit flange is not facing the ship's bow, rotate the transducer so that the bow mark on the transducer points toward the ship's bow (see section 3.9).
4. Confirm the following points, then place the hull unit on the retraction tank.
 - Clean the flange platform.
 - Wipe the undersurface of the hull unit flange with clean waste cloths.
 - Keep O-ring in its groove.

1. HOW TO INSTALL THE SYSTEM

5. Coat the threads of the bolts with a slight amount of lithium grease to prevent scorching, then secure the hull unit to the retraction tank, referring to the following figure.

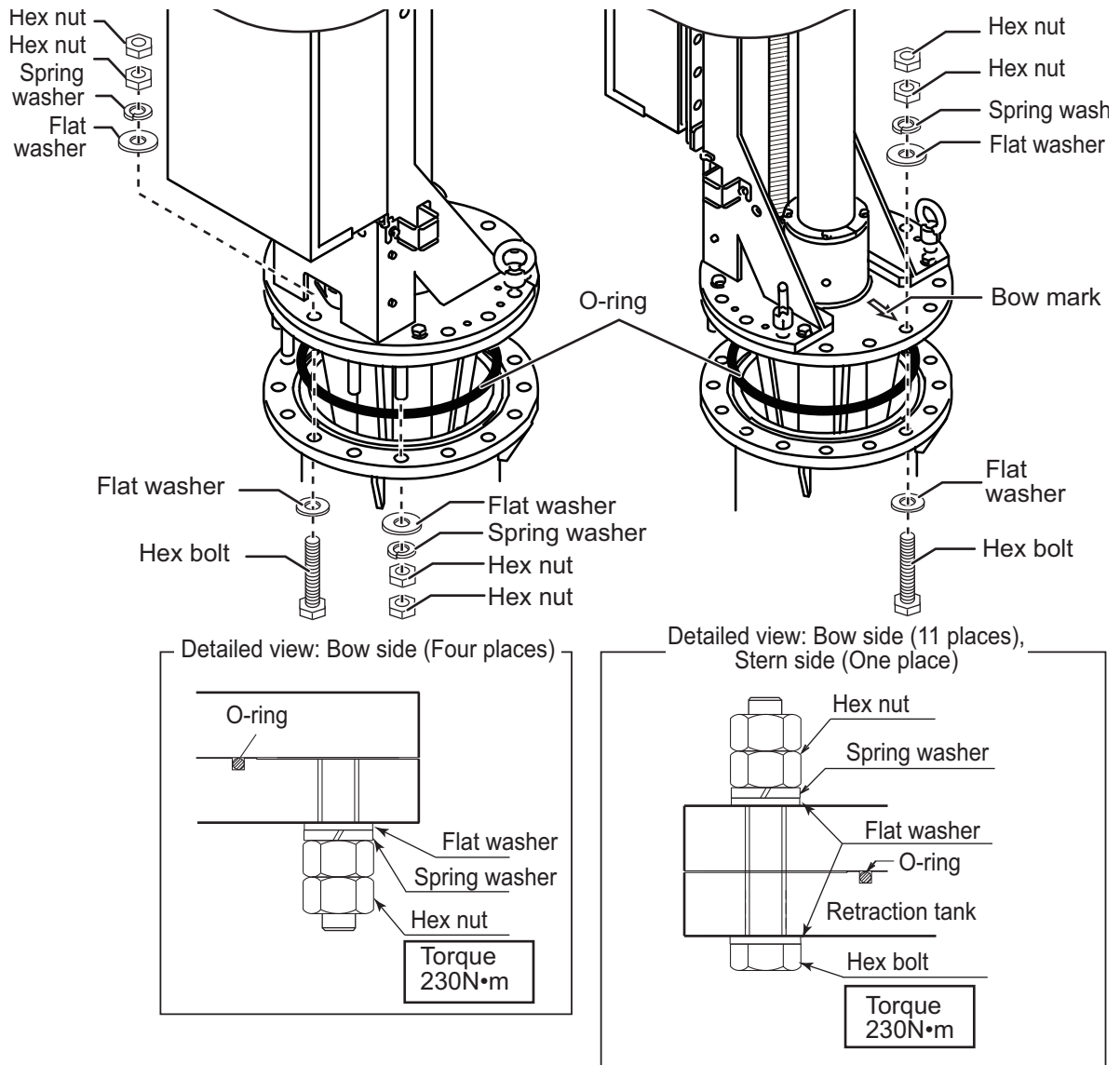

How to remount the emergency switch

The emergency switch is attached to the starboard side of the hull unit. If the starboard side clearance is not sufficient for switch operation, the switch may be remounted on the port side.

1. Unfasten the four screws to remove the box base.
2. Unfasten the two screws to remove the box cover.

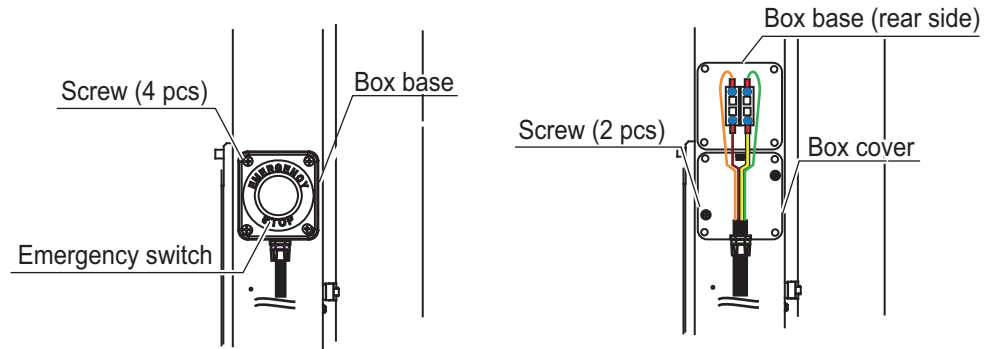

3. Remount the emergency switch to the port side.
4. Secure the emergency switch cable, using the three wiring bands. Wiring band must be secured to the hull unit, using pan head screws (M4×12).

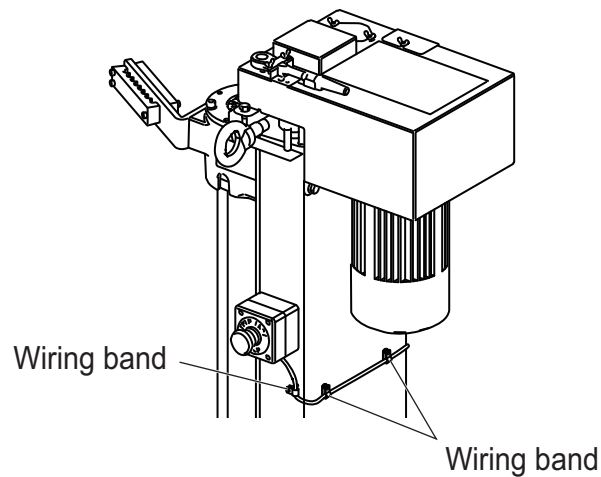

1. HOW TO INSTALL THE SYSTEM

How to install the stays (anti-vibration and anti-shock measures)

This measure must be done after installing the hull unit to prevent damage from vibration or impact shock to the transducer. Stays should be as sturdy as possible (75×75×9 mm minimum recommended). Install a minimum of two stays, one in the aft direction, one in the fore direction. Where possible install two more stays (one in the port and one in the starboard direction), making a total of four stays. Where the hull unit is installed off center from the bow-stern line, install the stays at right angles with the bow mark on the hull unit.

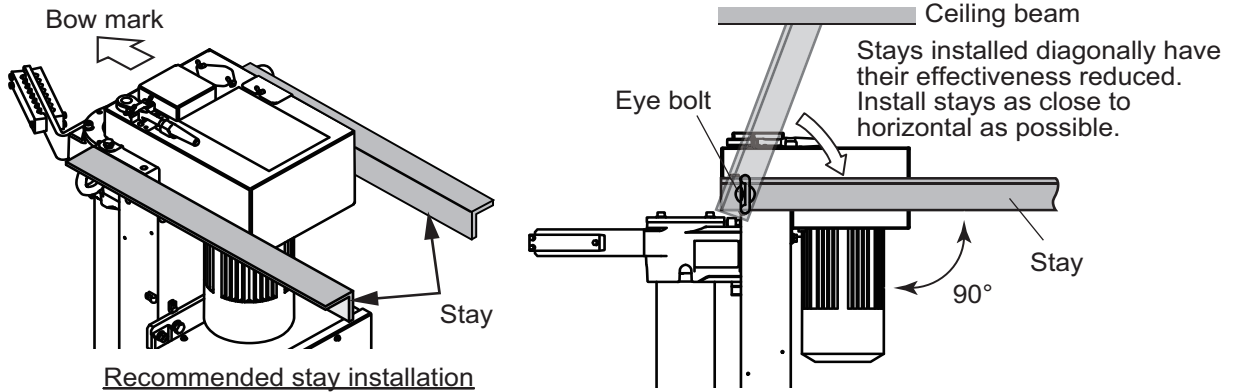

Where horizontal installation of the stays is not possible, install the stays in a diagonal manner to reduce vibration in the hull unit.

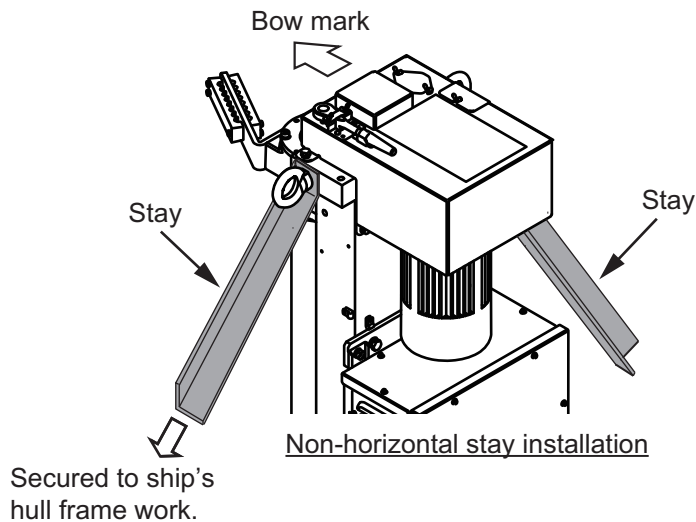

1.1.4 How to adjust the TX limit switch position

Adjust the TX limit switch position so that the switch is turned on where the transmitting face of the transducer is projected from the hull unit.

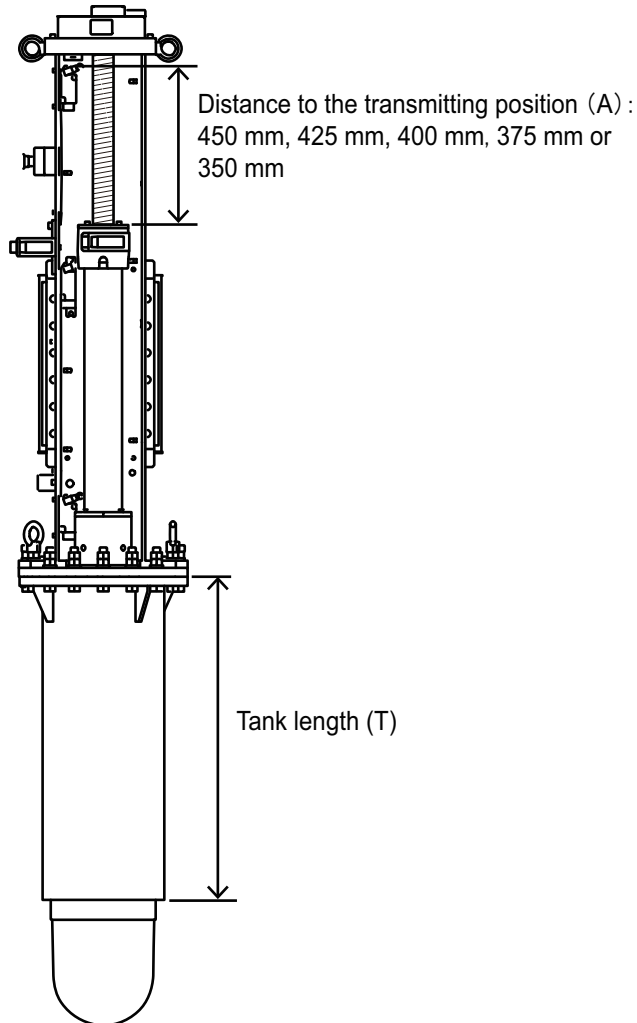

Distance to the transmitting position (A) can be selected from 450 mm, 425 mm, 400 mm, 375 mm or 350 mm. The distance to the transmitting position can be calculated with the following formula. Select the value closest to the calculation.

- $A = T - 450 \text{ mm}$

For example, when the tank length (T) is 820 mm, the calculated value is “ $A = 820 - 450 = 370 \text{ mm}$ ”. Therefore, adjust the TX limit switch so that the distance to the transmitting position is 375 mm.

Note: The transducer can transmit when the transducer is projected 300 mm from the retraction tank.

1. HOW TO INSTALL THE SYSTEM

At factory default, the distance to the transmitting position is 450 mm (tank length: 900 mm). To adjust the distance to the transmitting position, unfasten the two mounting screws (M6) to remount the TX limit switch.

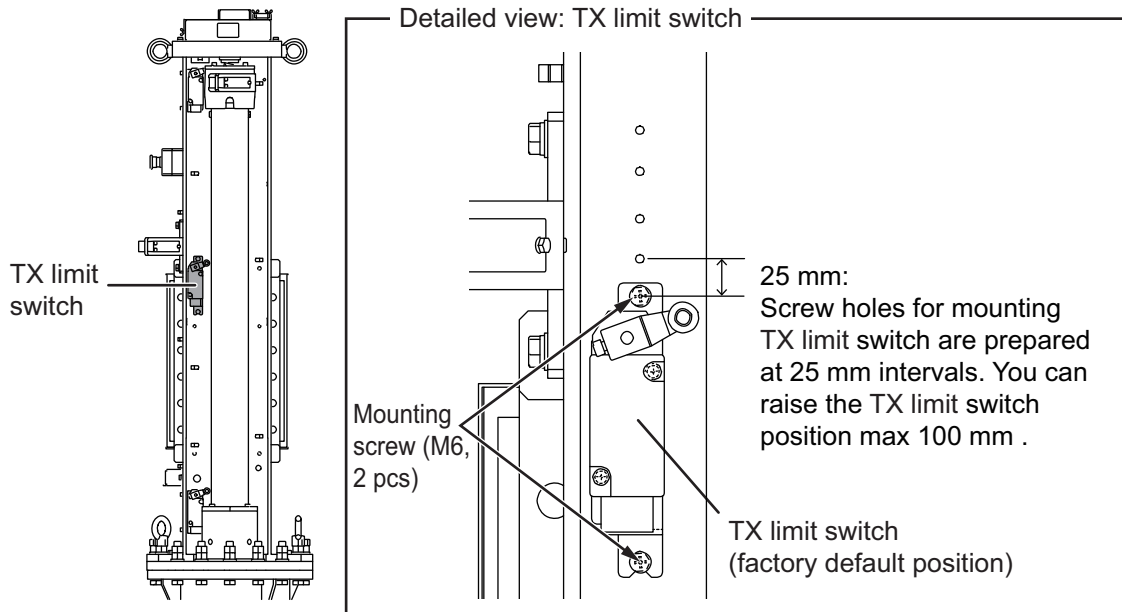

1.2 Processor Unit

The processor unit can be installed on a deck or bulkhead.

Mounting considerations

Select a mounting location, keeping in mind the following points:

- Locate the unit out of direct sunlight and away from heat sources.
- Locate the unit away from places subject to water splash and rain.
- Select a mounting location considering the length of the cables to be connected to the unit.
- Select a location where shock and vibration are minimal.
- Be sure the mounting location is strong enough to support the weight of the unit.
- Referring to the outline drawings at the back of this manual, allow sufficient space for maintenance and service.
- A magnetic compass will be affected if the unit is placed too close to the magnetic compass. Observe the compass safe distances at the front of this manual to prevent interference to a magnetic compass.
- For the bulkhead installations, secure the unit so that the cable entrance faces downward.

1.2.1 Deck mount

1. Drill four pilot holes in the mounting location for mounting screws (M6 bolts or coach screws $\phi 6$), referring to the outline drawing at the back of this manual.
2. Secure the unit using the four mounting screws (supplied locally).

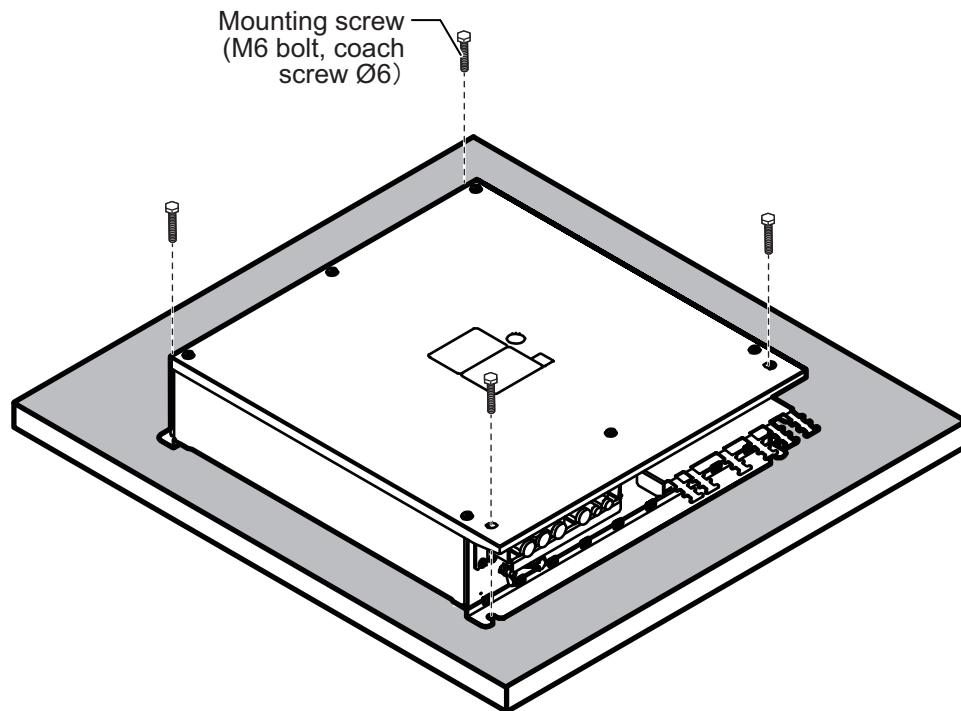

1. HOW TO INSTALL THE SYSTEM

1.2.2 Bulkhead mount

1. Drill four pilot holes in the mounting location for mounting screws (M6 bolts or coach screws $\phi 6$), referring to the outline drawing at the back of this manual.
2. Screw two mounting screws (supplied locally) into the lower pilot holes. Leave 5 mm of thread visible.
3. Set the notches of the unit onto the screws fastened at step 2.
4. Screw two mounting screws (supplied locally) into the upper fixing holes.
5. Fasten all screws tightly to secure the unit in place.

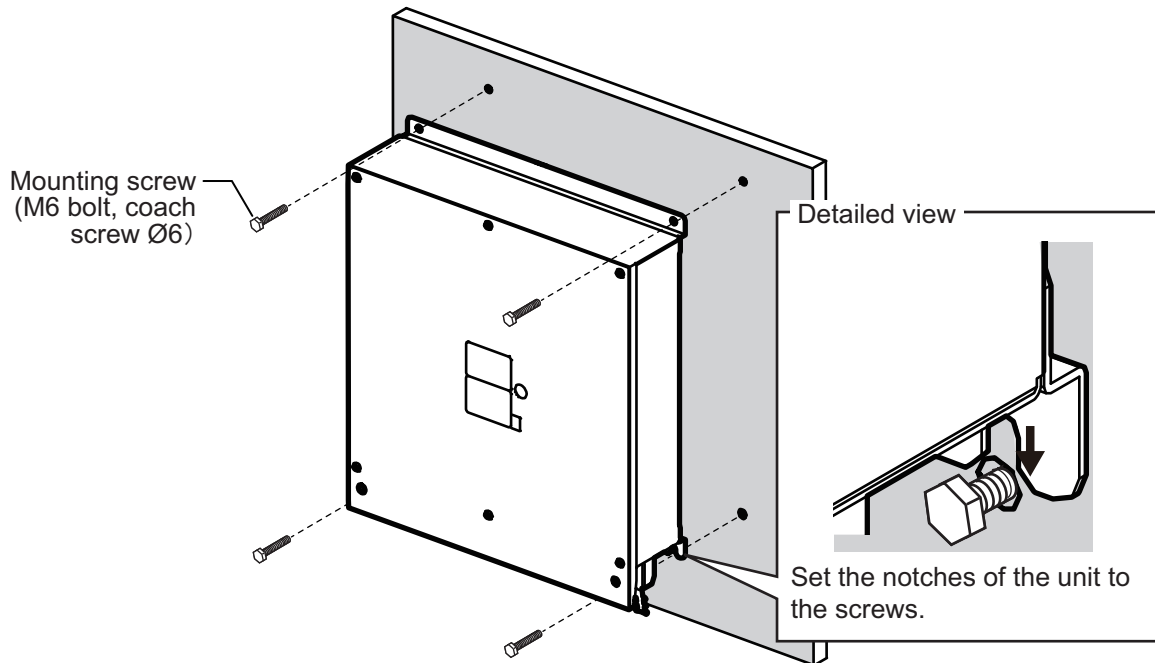

1.3 Control Unit

The control unit has following three mounting methods:

- Tabletop mounting: The unit is secured from the underside.
- Tabletop mounting with KB fixture: The unit is secured from the topside.
- Flush mounting

Mounting considerations

- Select a location where the unit can easily be operated.
- Locate the unit out of direct sunlight.
- Locate the unit away from places subject to water splash and rain.
- Select a location where shock and vibration are minimal.
- Select a mounting location considering the length of the cable.
- Referring to the outline drawings at the back of this manual, allow sufficient space for maintenance and service.
- A magnetic compass will be affected if the unit is placed too close to the magnetic compass. Observe the compass safe distances at the front of this manual to prevent interference to a magnetic compass.
- For flush installations, select a location where the surface is flat.

1.3.1 Tabletop mounting without KB fixture

1. Drill four pilot holes in the mounting location for stud bolts (M4×50), referring to the outline drawing at the back of this manual.
2. Attach a ground wire (IV-1.25sq, supplied locally) to the ground terminal at the bottom of the unit, then connect the other end of the ground wire with the ship's ground.
3. Insert four stud bolts (M4×20, supplied) to the bolt holes at the bottom of the unit.
Note: Insert the stud bolts manually. Do not use a tool to insert the bolts - the unit may become damaged.

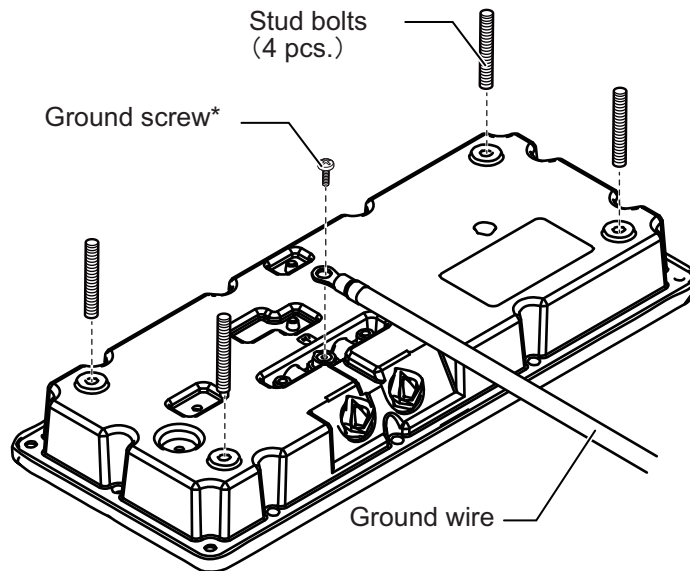

*: Use the screw that is preattached to the ground terminal.

4. Set the unit to the mounting location so that the stud bolts on the bottom of the unit are inserted to the pilot holes.
Note: Be careful to prevent the ground wire from being caught between the unit chassis and mounting surface.

1. HOW TO INSTALL THE SYSTEM

5. Fasten the four wing nuts (supplied) to the stud bolts from the rear side of the mounting surface.

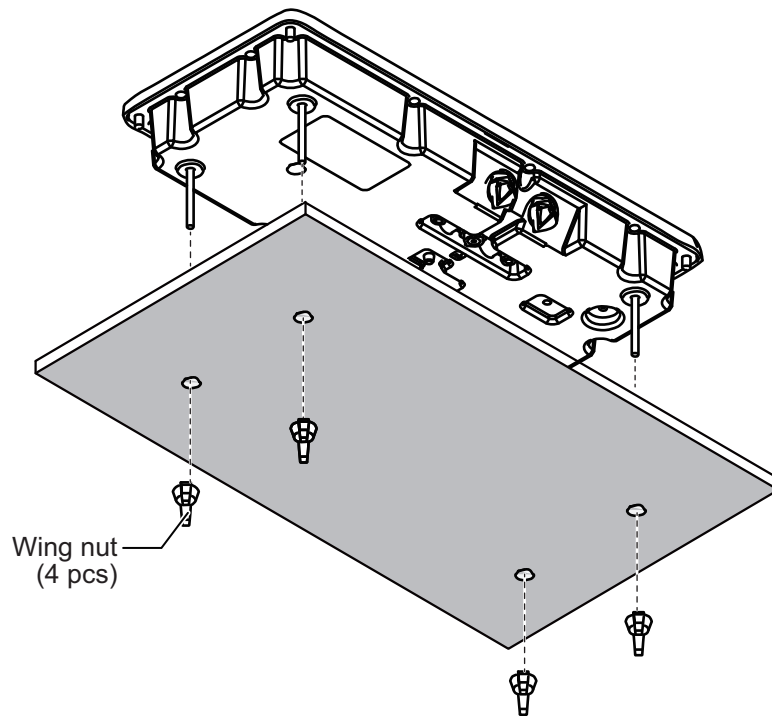

1.3.2 Tabletop mounting with KB fixture

The control unit can be mounted with the KB fixture, which mounts the unit at an angle.

1. Drill four pilot holes in the mounting location for mounting screws, referring to the outline drawing at the back of this manual.
2. Secure the KB fixture (supplied) to the mounting location, using four self tapping screws ($\phi 5 \times 20$, supplied).

Note: Secure the KB fixture so that the cutout is located on the side farthest from the operator.

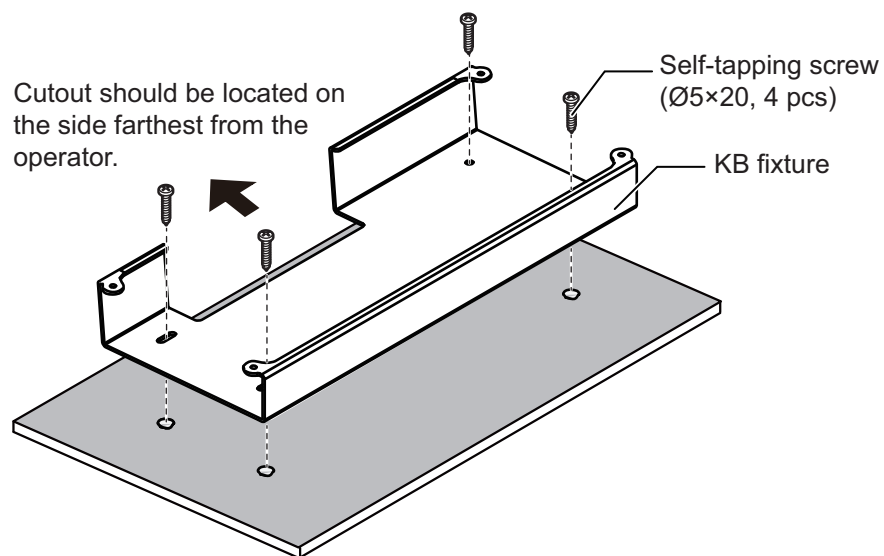

3. Attach a ground wire (IV-1.25sq, supplied locally) to the ground terminal at the bottom of the unit, then connect the other end of the ground wire with the ship's ground.

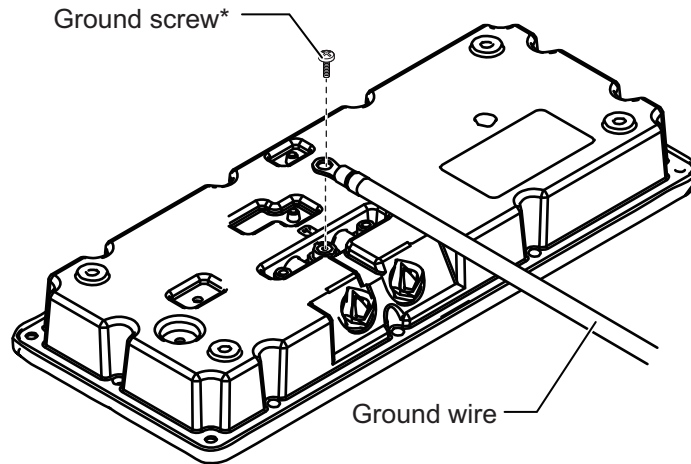

*: Use the screw that is preattached to the ground terminal.

4. Secure the control unit the KB fixture, using four binding screws (M5×20, supplied).
5. Attach four bolt hole caps (supplied).

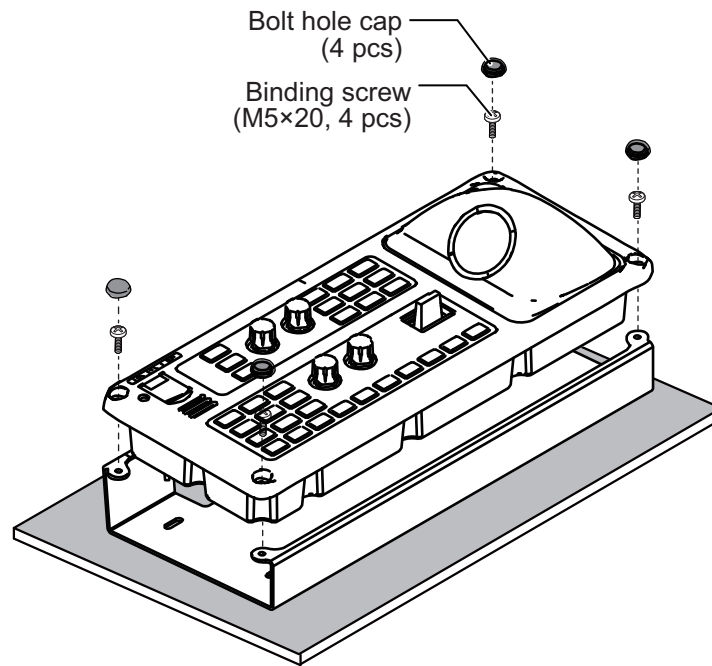

1.3.3 Flush mounting

Note: Be sure the mounting surface is flat.

1. Referring to the outline drawing at the back of this manual, prepare a cutout, then drill four pilot holes in the mounting location.

1. HOW TO INSTALL THE SYSTEM

2. Attach a ground wire (IV-1.25sq, supplied locally) to the ground terminal at the bottom of the unit, then connect the other end of the ground wire with the ship's ground.

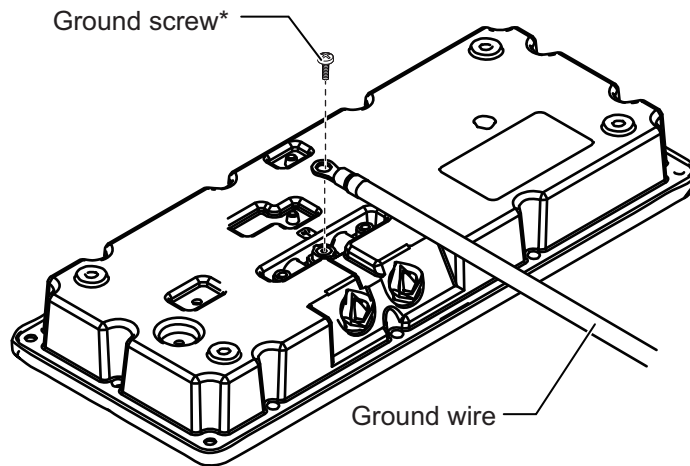

*: Use the screw that is preattached to the ground terminal.

3. Set the unit to the cutout, then secure the unit with four self-tapping screws ($\phi 5 \times 20$, supplied).
4. Attach four bolt hole caps (supplied).

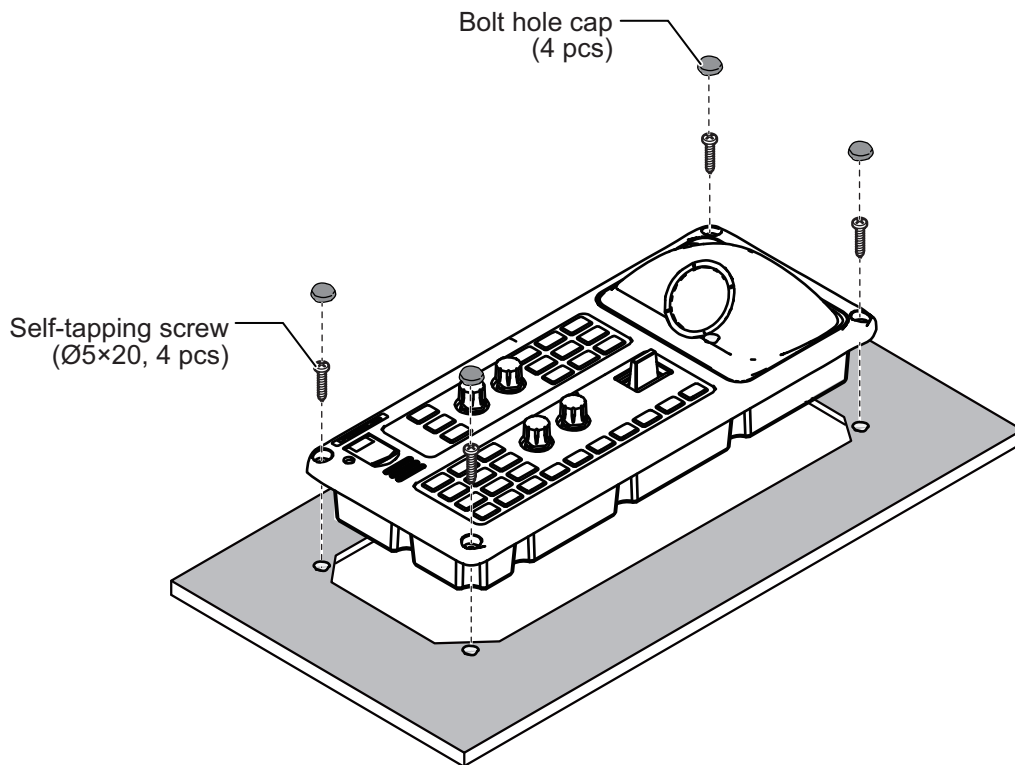

1.4 Transceiver Unit

Select a mounting location considering that the effective length. The transceiver unit should be fixed to a mounting base (shipyard supply) whose dimensions are as shown in the outline drawing at the back of this manual. Reinforce the transceiver unit against vibration by stays extending from the eye-bolts on the top of the unit. Fasten four bolts (M12, local supply) at the bottom of the transceiver unit to fix the unit to the mounting base.

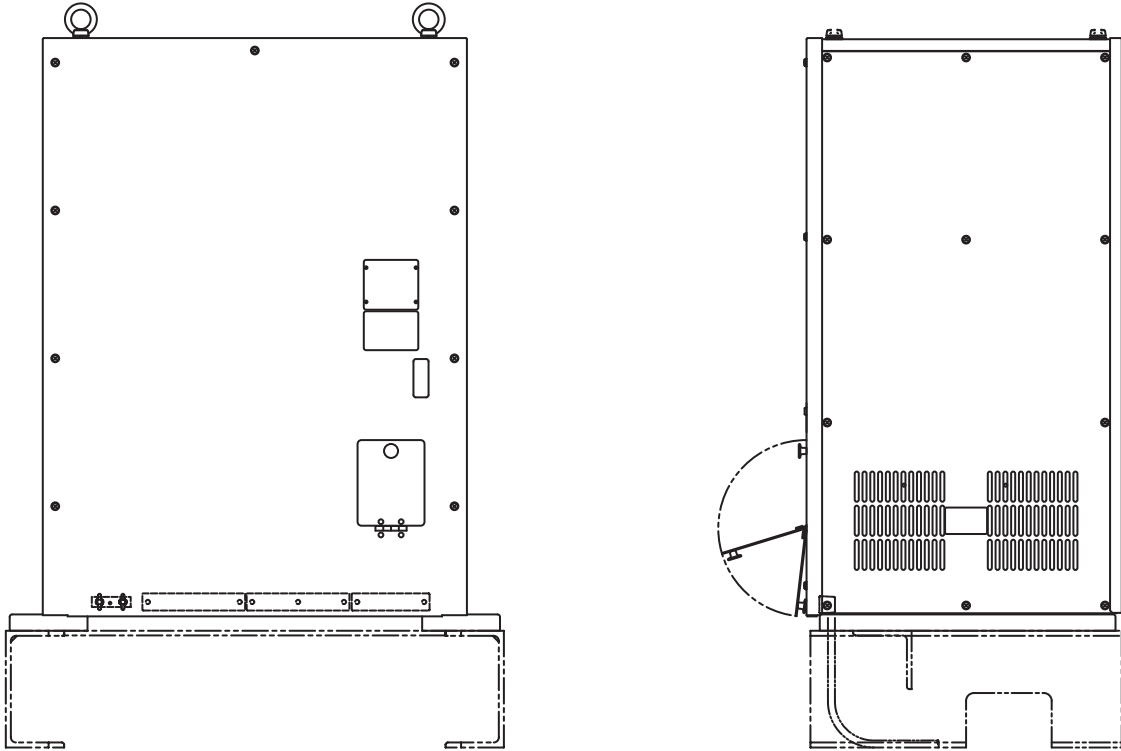

1.5 Raise/Lower Control Box

The inertial measurement unit is installed in the raise/lower control box. When using the control box extension box, remove the two fans from the raise/lower control box and install them in the control box extension box. Install the inertial measurement unit in the control box extension box, then secure the control box extension box to the hull unit.

How to attach the raise/lower control box to a bulkhead

When using the control box extension box, the raise/lower control box can only be installed on a bulkhead. Use 4×M10 bolts to fasten the raise/lower control box in position.

The internal electromagnetic switches only function correctly if the raise/lower control box is installed in the correct orientation, as shown in the figure below.

Note 1: When installing the inertial measurement unit inside the raise/lower control box, you must enter the location and angle of the raise/lower control box for heading correction. (See section 3.9 for how to adjust the heading.)

Note 2: The inertial measurement unit must be installed inside the control box extension box. The unit is extremely shock sensitive, take care not to drop it. Where possible, install the unit after the control box extension box has been installed.

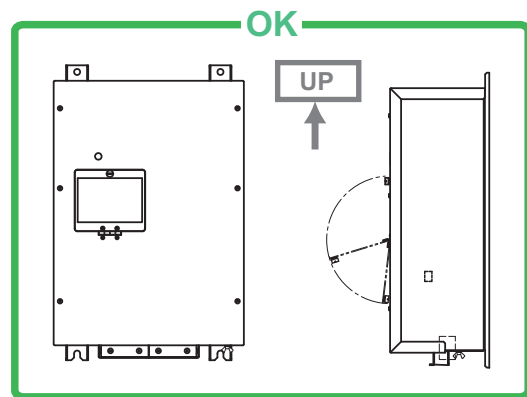

1.6 Control Box Extension Box

The control box may be mounted separately from the hull unit. Detach the control box and the mounting plate from the hull unit and fix the junction box of the control box to the hull unit. When securing the extension box, change the location of mounting plate (see below figure).

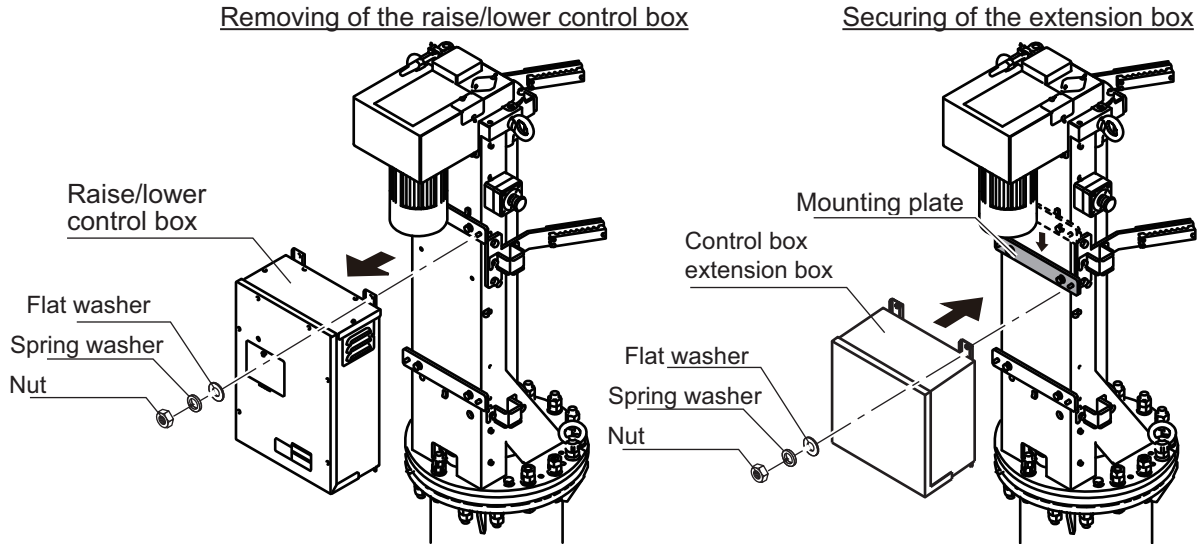

1.7 Attachment Kit (option)

The attachment kit permits use of the retraction tank for the CSH-80 series.

OP10-30. Code No. 000-067-179

Name	Type	Code No.	Qty
Insulation Gasket (1)	SHG-0003-1	100-038-571	1
Insulation Gasket (2)	MS-1000-68-1	100-347-611	16
O-ring	C00117A	000-158-976-10	1

- Clean the flange and O-ring groove of the retraction tank (welded to hull) with ethyl alcohol moistened waste cloths. Coat O-ring and O-ring groove with lithium grease. Place the O-ring in its groove on the tank flange.
- Lay the insulation gaskets (1) on the top of the tank flange.
- Position the hull unit so that the bow mark (inscribed) on its flange points toward the ship's bow. Note that heading adjustment in the monitor is required if the bow mark does not physically face the ship's bow.
- Confirm the following points as below and place the hull unit on the tank.
 - Clean the flange platform.
 - Wipe the undersurface of the hull unit flange with clean waste cloths.
 - Keep O-ring in its groove.
- Insert the flat washers and insulation gaskets (2) into the bolt holes of the tank flange.
- Coat threads of the bolts with a slight amount of lithium grease to prevent scorching. Insert the bolts with washers from the retraction tank flange, and then put the flat washers and spring washers in this order from above. Fasten bolts with nuts.

1. HOW TO INSTALL THE SYSTEM

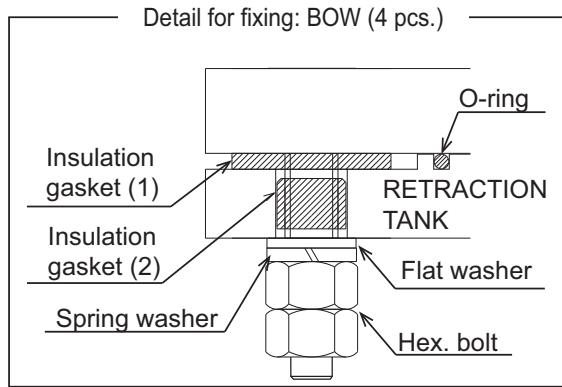
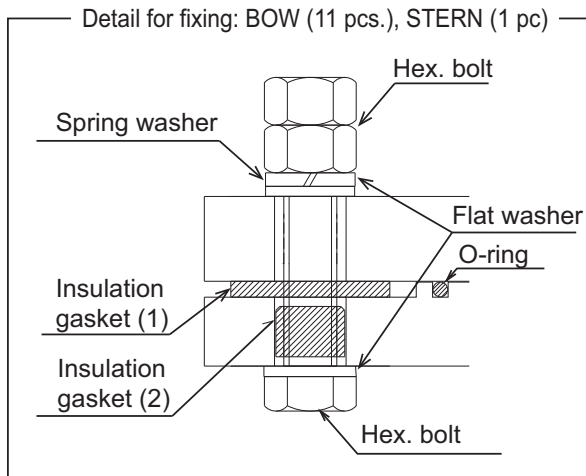
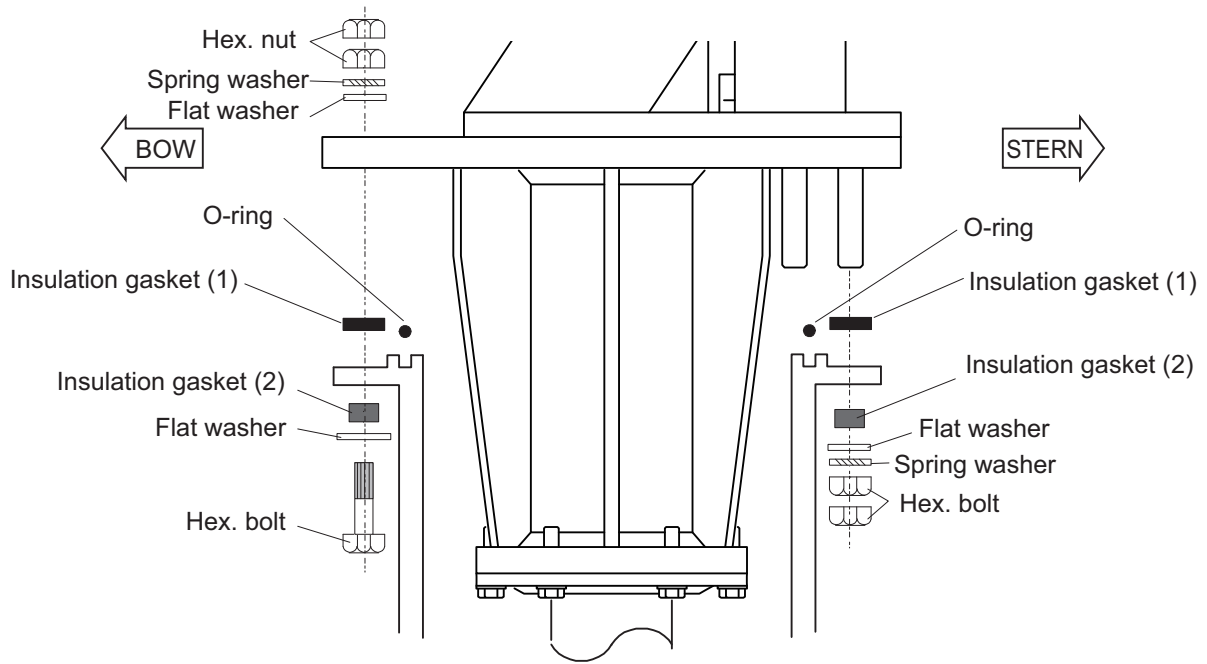

1.8 How to Fill the Soundome with Antifreeze

Fill the soundome with antifreeze as shown below.

IF THERE IS SUFFICIENT ROOM

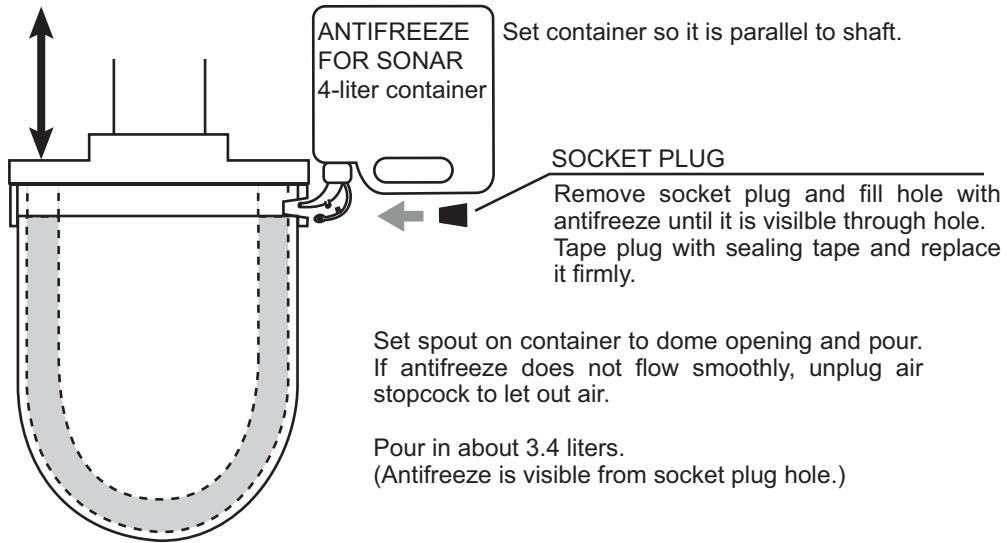

IF THERE IS NOT ENOUGH ROOM, USE FUNNEL

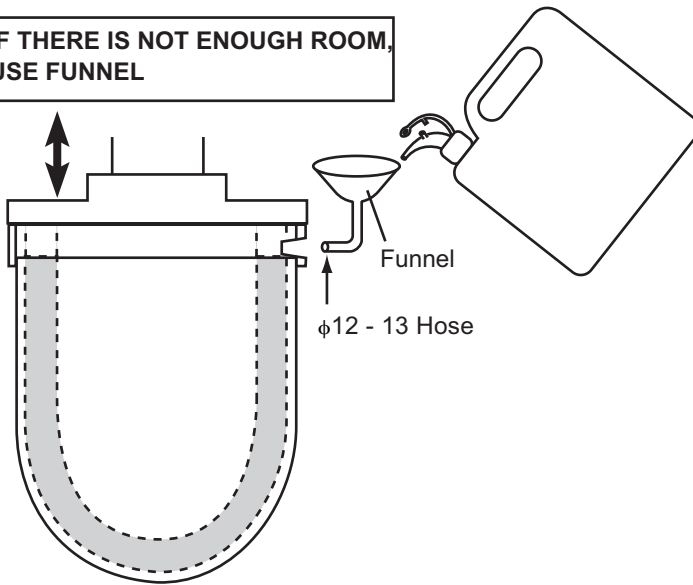

WHEN SHIP IS DRY DOCKED

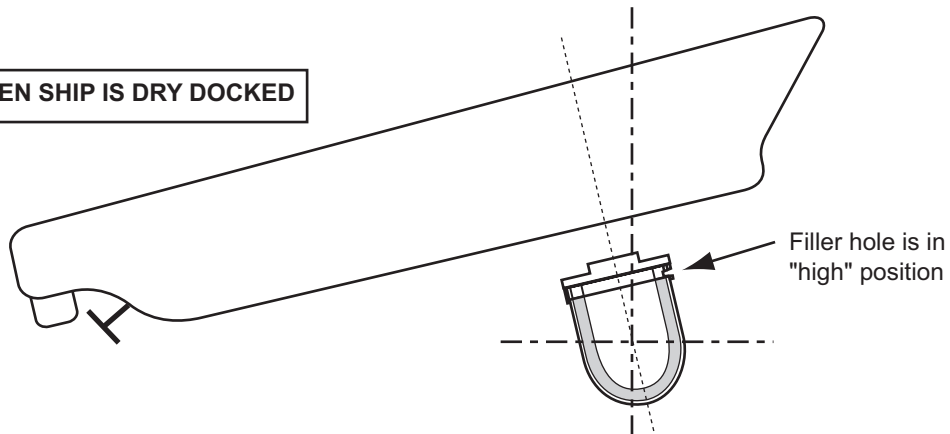

NOTICE: When the ship is dry docked, drain antifreeze from dome when temperature is lower than -20°C. Failure to do so can damage the dome.

1.9 FRP Tank (option)

Use an FRP tank supplied by FURUNO. Other makes of tank may be used, however watertightness cannot be guaranteed by FURUNO. A non-FURUNO make of tank should meet the following requirements:

- The surface of the FRP tank flange must be flush (within 0.5 mm) with tank.
- Use the liquid gasket recommended by shipyard.

Contents of FRP retraction tank installation kit

Name	Type	Code No.	Qty
Retraction Tank	OP10-29-1	007-022-920	1
Waterproofing Gasket	SHH-0003-1	660-800-031	1
Liquid Gasket*	TB1121 200G	000-193-909-10	1

*: Liquid gasket is not supplied with the FRP tank, because of export restrictions in each country. Prepare TB1121 or TB1184 (ThreeBond Holdings Co., Ltd.) locally.

1.9.1 How to install the hull unit to an FRP tank

Fasten the hull unit to the FRP retraction tank as follows:

1. Clean the surface of the tank flange with ethyl alcohol moistened waste cloths.
2. Apply approx. 1 mm thickness of liquid gasket (TB1121 or TB1184) to the retraction tank flange. For the application area, see the following figure.

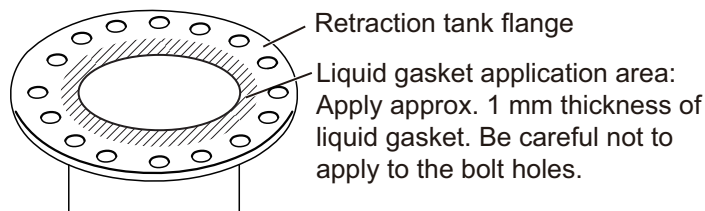

3. Lay the waterproofing gasket on the tank flange.
Note 1: Do not apply liquid gasket to the waterproofing gasket. If applied, clean the gasket with waste cloth.
Note 2: Use only specified waterproofing gasket.
4. Position the bow mark (arrow) on the hull unit flange toward ship's bow. (If the mark can not be perfectly oriented toward ship's bow, adjust heading after installation, as shown later in this manual.

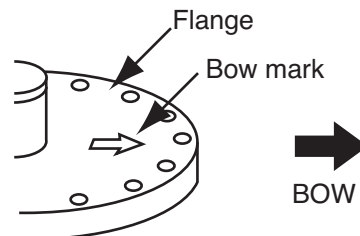

5. Set the hull unit on the top of the retraction tank, observing the following cautions:
 - Clean the flange platform.
 - Wipe the undersurface of the hull unit flange with clean waste cloths.
 - Confirm that the waterproofing gasket is properly in place.

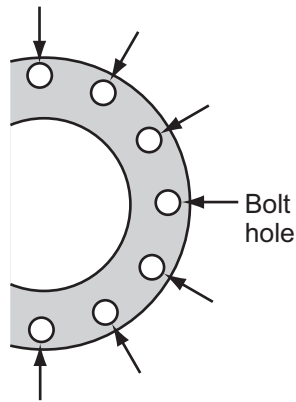

6. Coat threads of the bolts with a slight amount of lithium grease to prevent scorching. Insert the bolts with washers from the retraction tank flange, and then put the flat washers and spring washers in this order from above. Fasten bolts with nuts.

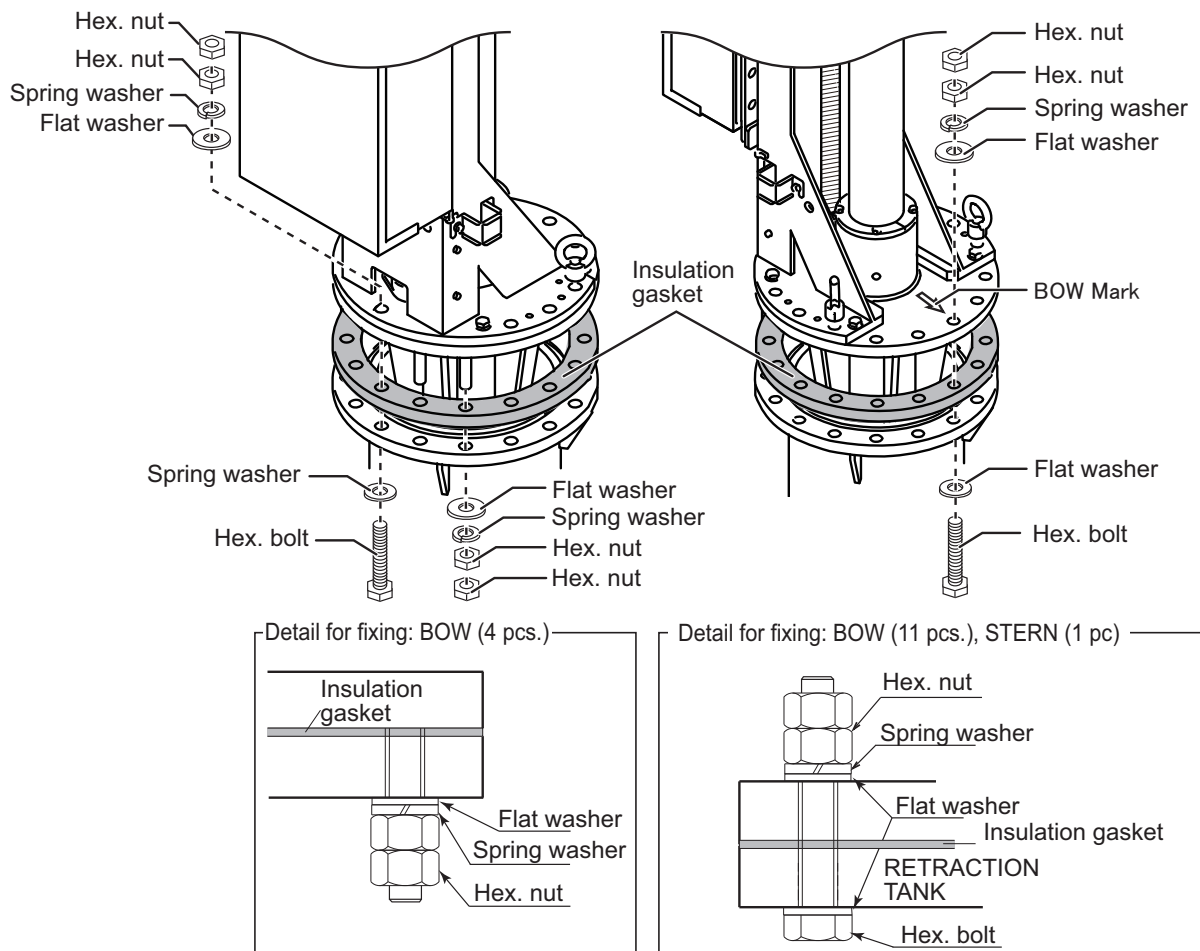

1.10 Sub Control Unit (option)

The control unit has following three mounting methods:

- Tabletop mounting: The unit is secured from the underside.
- Tabletop mounting with KB fixture: The unit is secured from the topside.
- Flush mounting

Mounting considerations

- Select a location where the unit can easily be operated.
- Locate the unit out of direct sunlight.
- Locate the unit away from places subject to water splash and rain.
- Select a location where shock and vibration are minimal.
- Select a mounting location considering the length of the cable.
- Referring to the outline drawings at the back of this manual, allow sufficient space for maintenance and service.
- A magnetic compass will be affected if the unit is placed too close to the magnetic compass. Observe the compass safe distances at the front of this manual to prevent interference to a magnetic compass.
- For flush installations, select a location where the surface is flat.

1.10.1 Desktop installation, with keyboard fixture

1. Fix the keyboard fixture to the bottom of the unit with the screws (M4x12) supplied.
2. Attach rubber feet (2 pcs.) to the bottom of the unit.
3. Fix the unit to the mounting location with self-tapping screws (local supply).

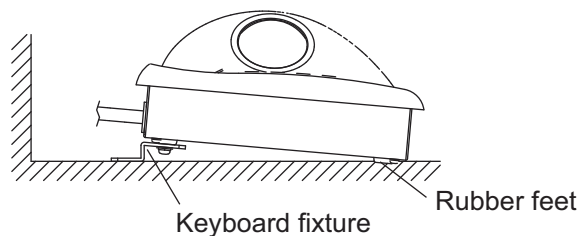

1.10.2 Desktop installation, no keyboard fixture

1. Drill four mounting holes of 5 mm diameter, referring to the outline drawing at the back of this manual.

- Fix the unit with four screws (M4) from under side of the desktop. (Supply the screws locally. Be sure the screws are of a sufficient length for the thickness of the desktop.)

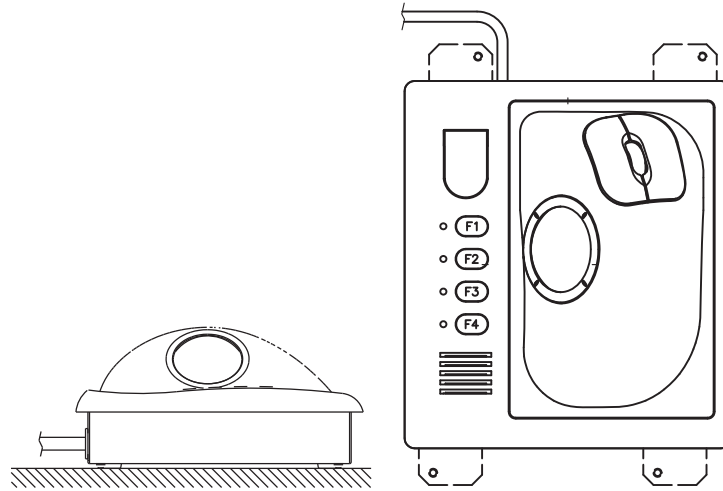

1.10.3 Flush mount (option)

Use the optional flush mount kit (Type: FP03-09870, Code No.: 008-535-630) to mount the sub control unit.

Name	Type	Code No.	Qty
Mounting plate	03-163-7531	100-306-261	4
Hex nut	M5	000-863-108	4
Wing screw	M5x40	000-162-682-10	4
Pan head screw	M4x12	000-163-192-10	4

- Prepare a cutout in the mounting location referring to the outline drawing at the back of this manual.
- Set the unit to the cutout.
- Attach the mounting plate to the unit with four screws from the rear side.
- Screw the wing screw to each mounting plate and then insert hex bolt to each wing screw.
- Fasten each wing screw and then fasten the hex nuts.

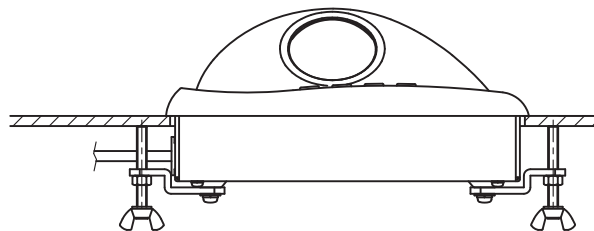

1. HOW TO INSTALL THE SYSTEM

This page is intentionally left blank.

2. WIRING

2.1 How to Use the Crimping Tool, Pin Extractor

A special crimping tool is necessary for connection of wires to the contact pins of the 38P connector. The pin extractor removes the contact pin from the connector body. This paragraph describes how to crimp and extract the contact pin.

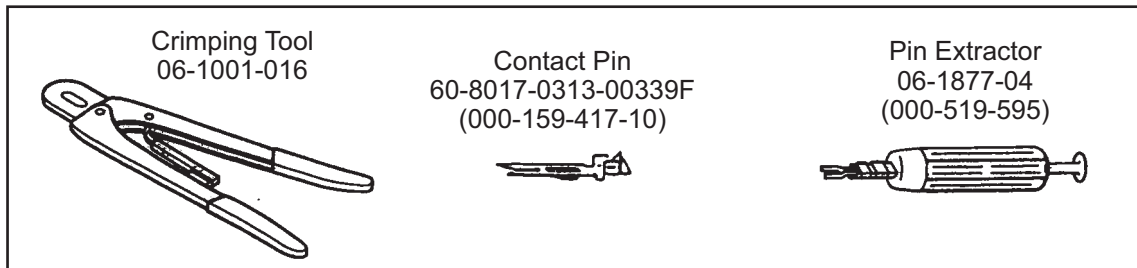

2.1.1 How to use the crimping tool

1. Remove the vinyl sheath by 3 to 4 mm to expose the core.
2. Hold the crimping tool horizontally and insert the contact pin with its slit facing downward into the crimp hole on the crimping tool.
3. Insert the wire onto the contact pin and squeeze the handle until the ratchet releases. (The wire should be placed deep enough into the contact pin so that its end comes in contact with the stopper plate of the crimping tool.)
4. With crimping completed, pull the wire while holding the contact pin to make sure that the wire is held firmly by the contact pin.

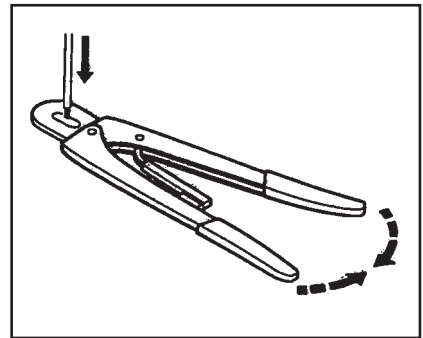

2.1.2 How to use the pin extractor

If a contact pin is inserted into an incorrect hole on the connector body, remove it with the pin extractor.

1. Push the pin extractor into the pin hole from the side opposite to the pin inserting side.
2. Push in the head of the pin extractor. The retaining spring comes free and the contact pin can be removed.

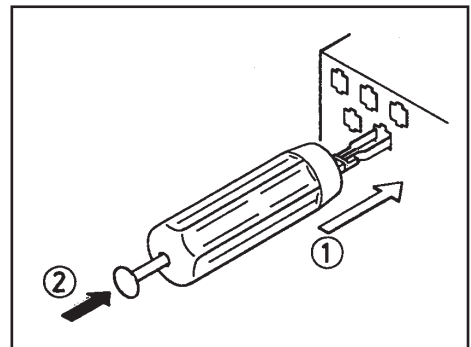

2.2 How to Connect Units

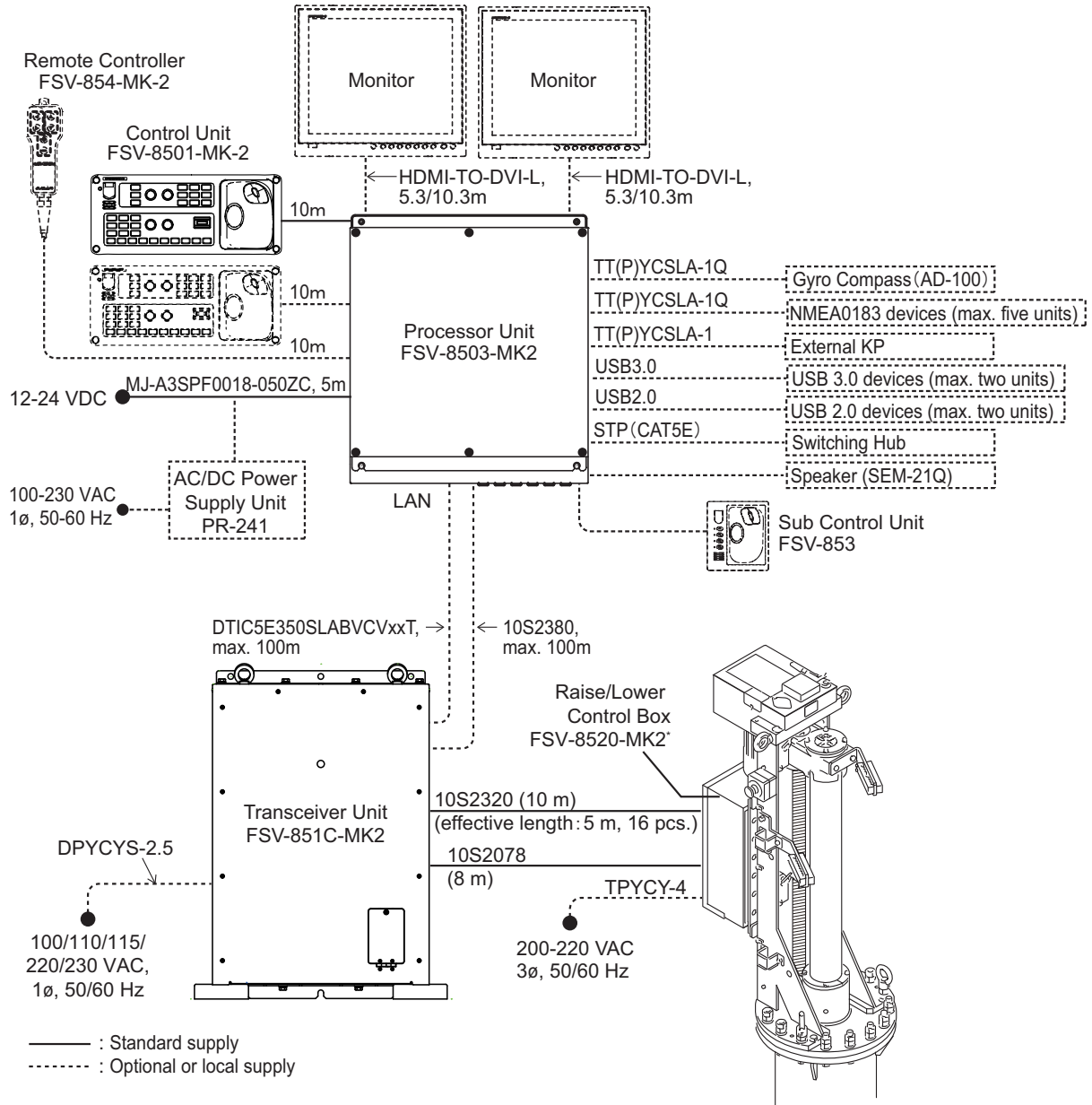

*: Use the optional Control Box Extension Box (FSV-2560) to extend the distance between the raise/lower control box and the hull unit.

Transducer cable

- The transducer cables (10S2320, 16 pcs) are secured on the cable securing plate. After installation of the hull unit, release the transducer cables from the cable securing plate for wiring. The cable securing plate can be removed and discarded after releasing the transducer cables.
- If the transducer cables are not quite long enough, unfasten the cable clamp to release the cables.

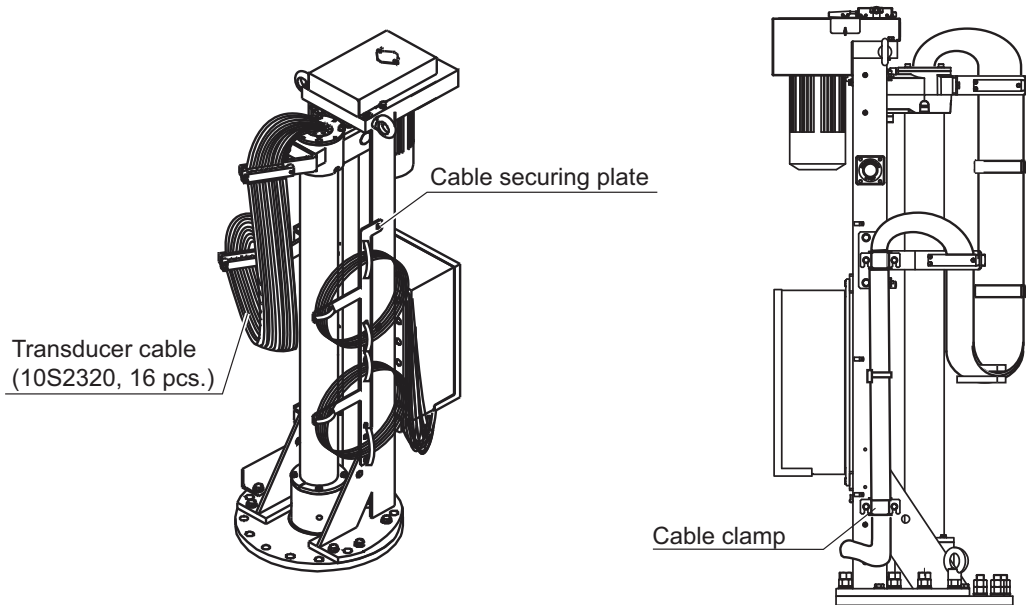

- When the transducer is removed from the hull unit while installing the hull unit, re-attach the transducer and route the transducer cables as shown in the following figure.

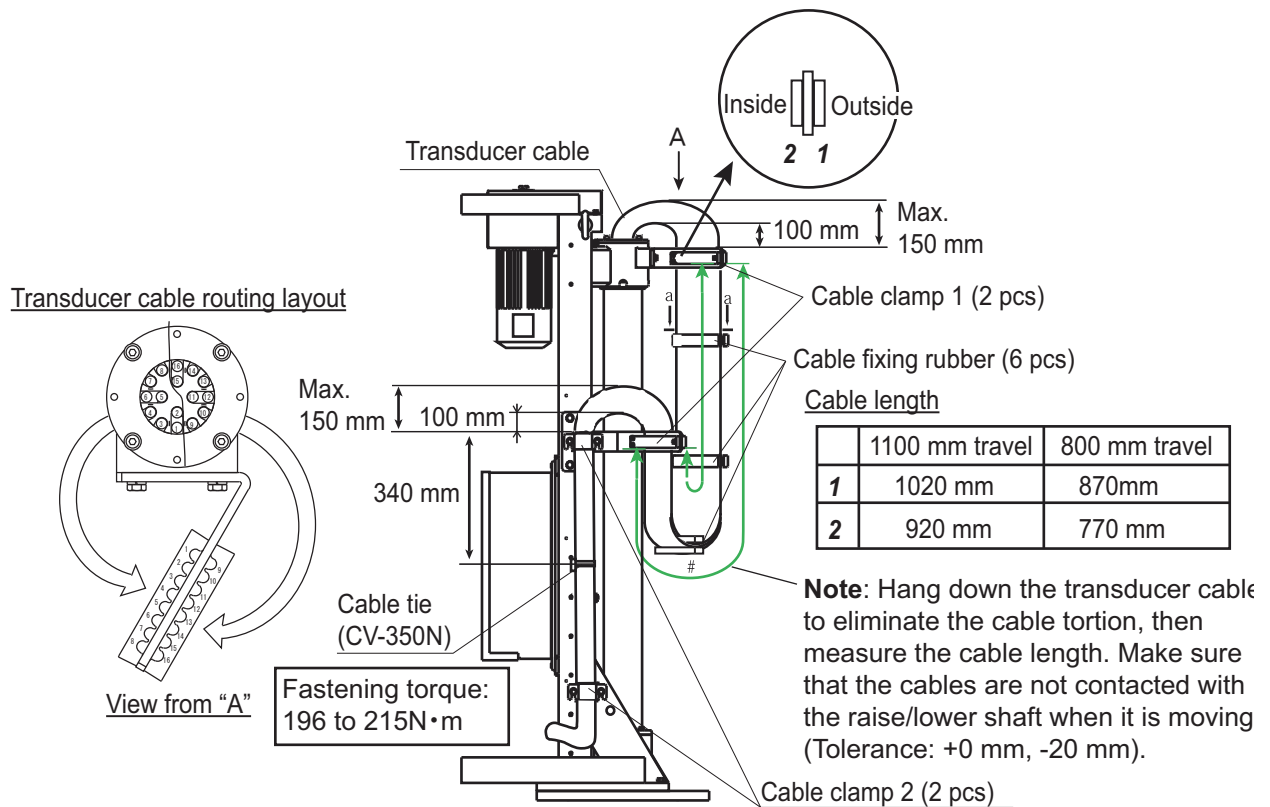

2. WIRING

How to attach the cable clamp 1

Fastening torque: 4.51 N·m

Upset screw (M5x30)

Use three screws to secure one cable clamp.

How to attach the cable clamp 2

Bind the transducer cables, using a vinyl tape, then secure the cables with the cable clamp.

Hex bolt (M8x16)

Fastening torque: 18.4 N·m

Appx. 20 mm

Vinyl tape (Width 90 mm)

How to attach the cable fixing rubber

Cross-section view: a-a

Outside routing cable

Slit

Inside routing cable

Note: The distance between inside and outside routing cable must be 30 to 40 mm, at the location “# (indicated in the figure on the previous page)”. Also, the distance between the flange and outside routing cable must be 100 to 120 mm.

Attach two cable routing rubber at the regular intervals between the cable clamps.

Ground

Ground the processor unit and the hull unit, using an IV-8 sq. wire or copper strap, to prevent electrical shock. The transceiver unit also must be grounded, also with an IV-8 sq. wire or copper strap of 50 mm width. The transceiver unit is supplied with a copper strap.

Cable between Raise/Lower Control Box and Transceiver Unit

The length of the cable between the raise/lower control box and transceiver unit is 8 m. Arrange it as shown below.

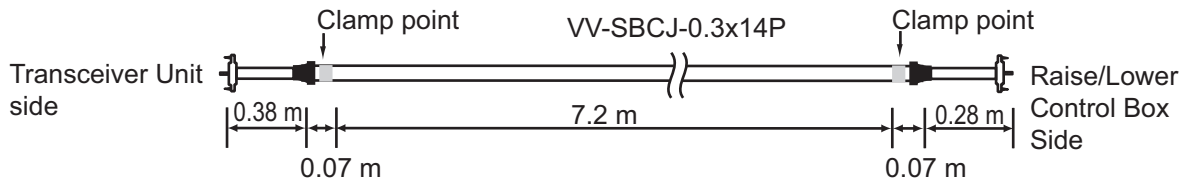

2.3 Processor Unit

2.3.1 Connectors

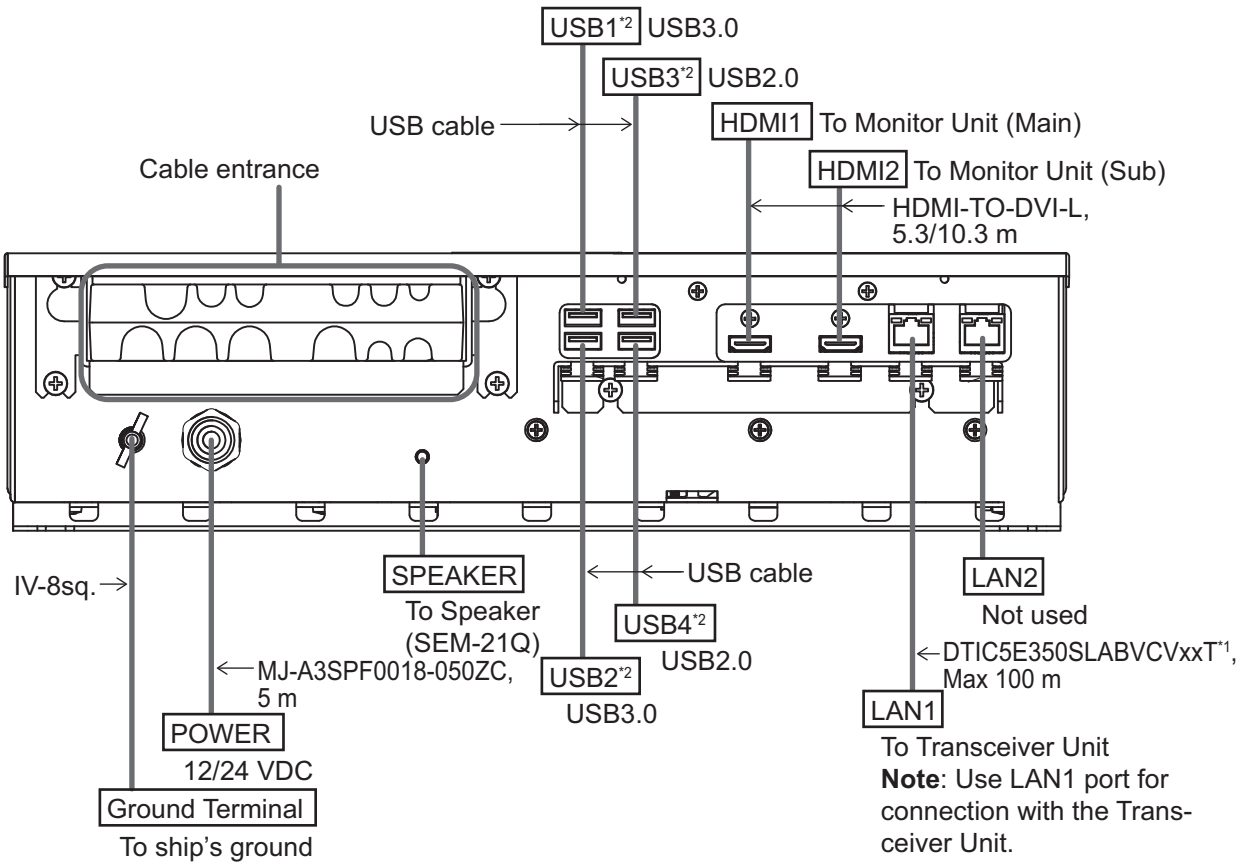

*1: Fabricate the cable referring to section 2.3.3.

*2: To connect a USB device, use the lower USB port first.

Secure the USB, HDMI and LAN cables to the cable clamp with a cable tie (supplied locally). For the USB cables, use two cable ties to secure the cable.

Note: The cable clamp can be adjusted to allow larger connectors, such as USB or HDMI, to be connected.

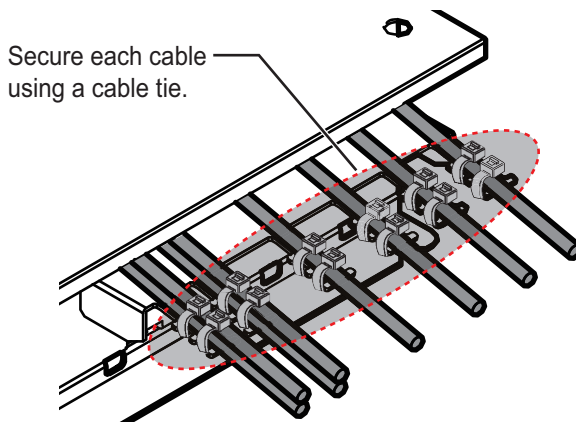

Unfasten the indicated screws to adjust the cable clamp. Refasten the screws to secure the cable clamp after adjustment.

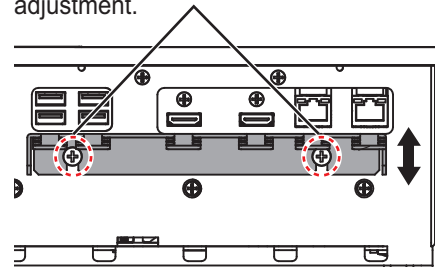

2. WIRING

2.3.2 Internal wiring and cable clamp position

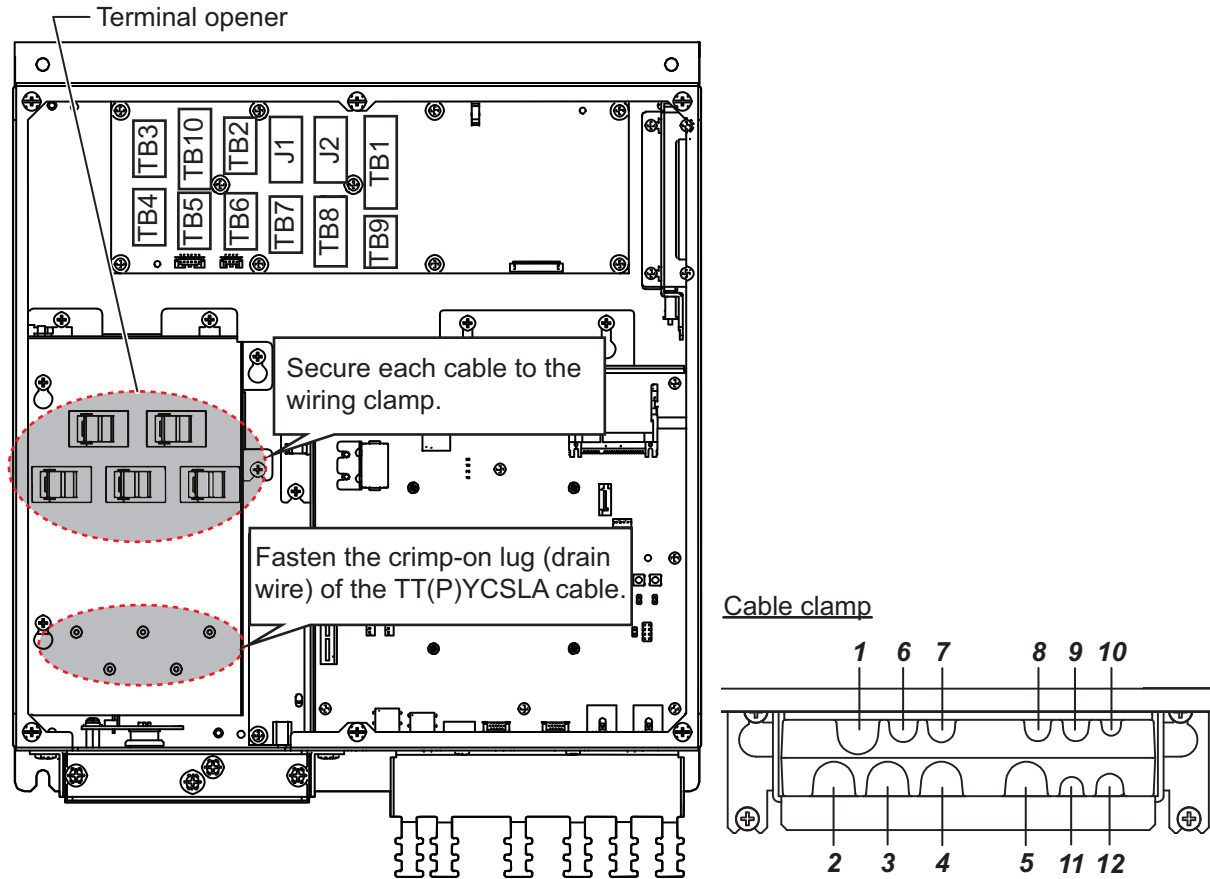

Clamp position	Connect to	Cable from	Cable
1	TB3	NMEA0183 equipment	TT(P)YCSLA--1Q*1
2	TB4		
3	TB5		
4	TB6		
5	TB7		
6	TB10	Transceiver unit	10S2380*1
7	TB2	Gyrocompass (AD-10)	TT(P)YCSLA-1Q*1
8	J1	Control unit	-
9	J2	Control unit	-
10	TB1	Remote controller, external switch*2	-
11	TB8	External KP*3	TT(P)YCSLA-1*1
12	TB9	Not used	

*1: Fabricate the cables referring to section 2.3.3.

*2: To connect an external switch, see section 2.3.5.

*3: To connect an external KP, see section 2.3.6.

2.3.3 Cable fabrication

10S2380 cable

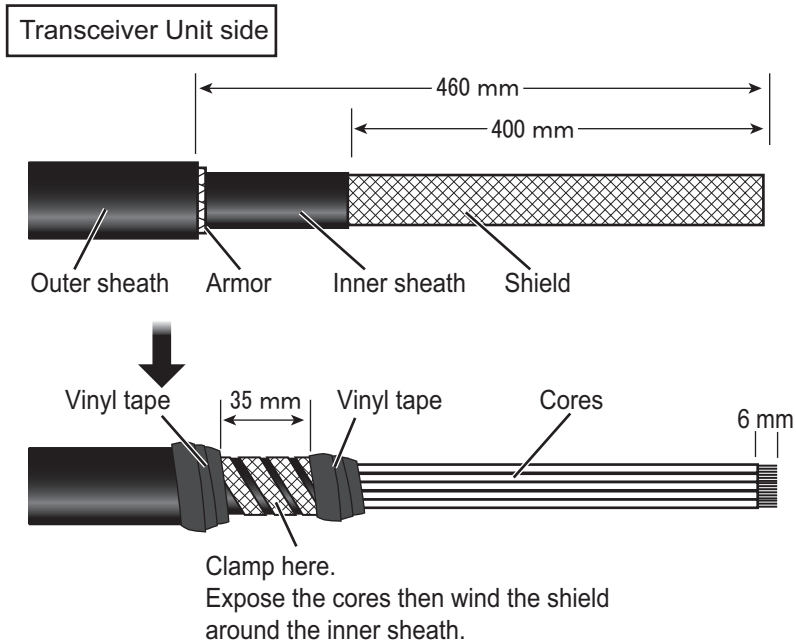
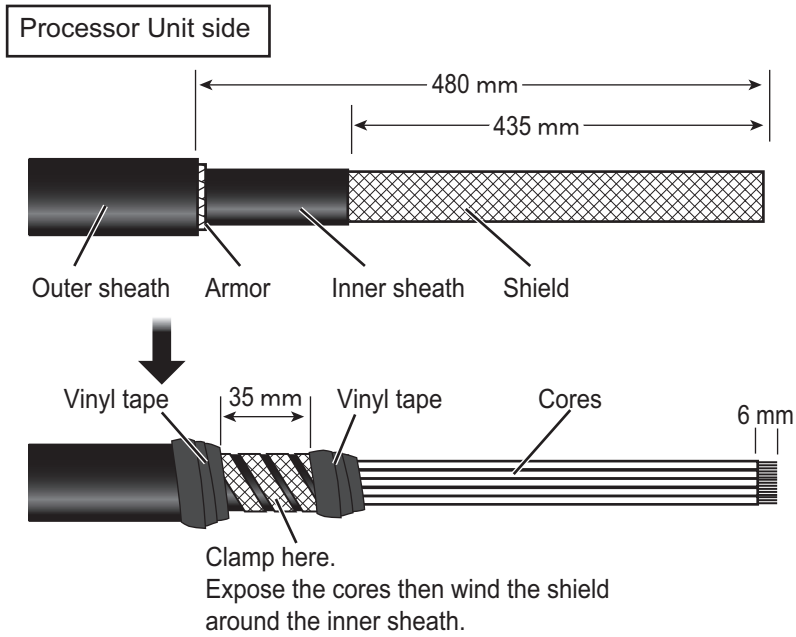

How to connect wires to a terminal connector

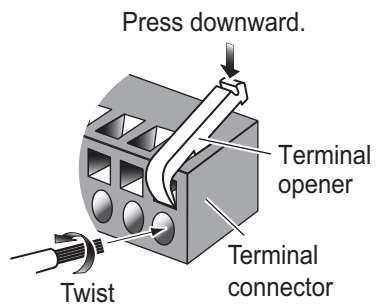

Procedure

1. Twist the cores.
2. Press the terminal opener downward.
3. Insert the wire in the hole.
4. Remove the terminal opener.
5. Pull the wire to confirm that it is secure.

2. WIRING

LAN cable

Fabricate the LAN cable (DTIC5E350SLABVCVxxT, max 100 m), referring to the following figure. After fabricating the cable, attach the modular connector.

Note: This equipment only uses straight cables. Use a CAT5E LAN cable.

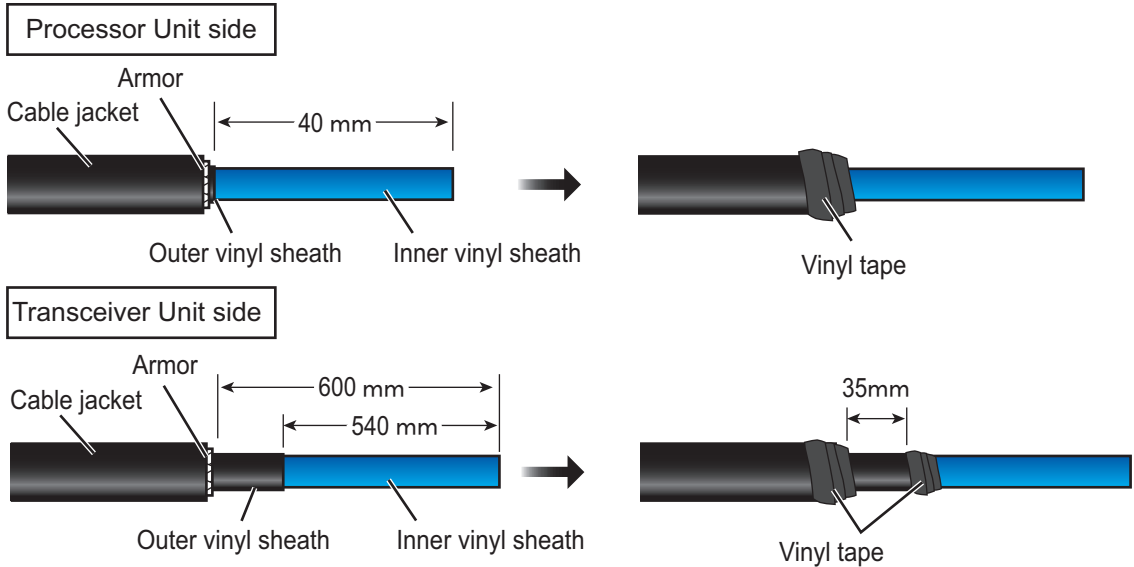

1 Expose inner vinyl sheath.



2 Remove the inner vinyl sheath by approx. 25 mm. Be careful not to damage inner shield and cores.

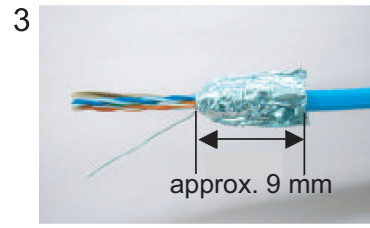

3 Fold back the shield, wrap it onto the inner vinyl sheath and cut it, leaving approx. 9 mm.

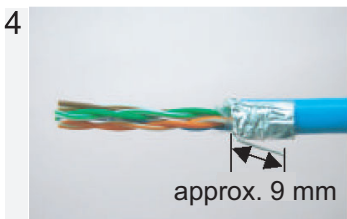

4 Fold back drain wire and cut it, leaving approx. 9 mm.

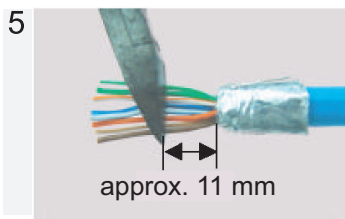

5 Straighten and flatten the cores in colored order and cut them, leaving approx. 11 mm.

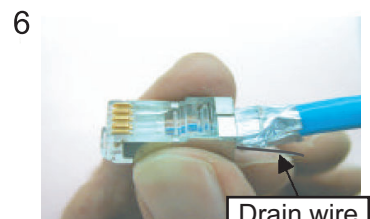

6 Insert the cable into the modular plug so that the folded part of the shield enters into the plug housing. The drain wire should be located on the tab side of the jack.



7 Using special crimping tool MPT5-8AS (PANDUIT CORP.), crimp the modular plug. Finally, check the plug visually.

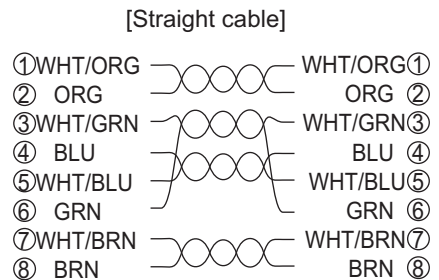
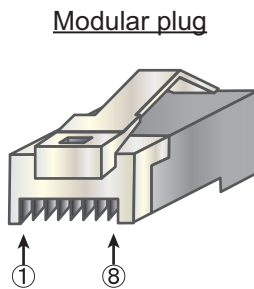

TT(P)YCSLA cable

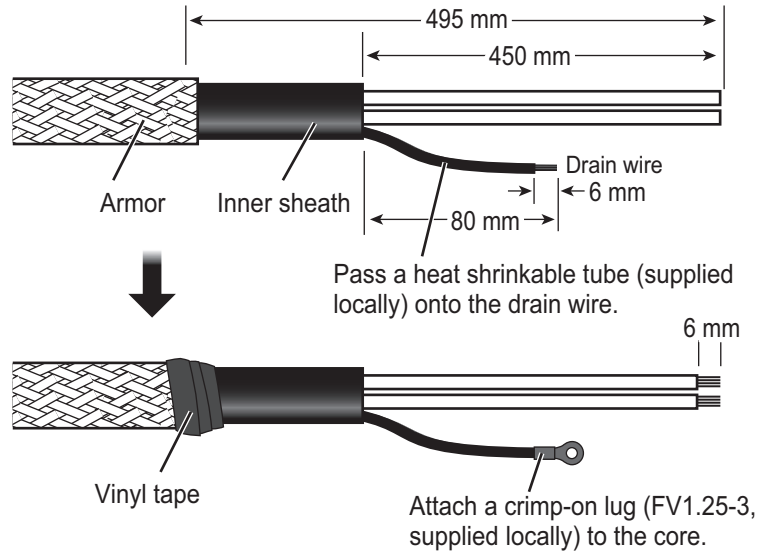

How to connect wires to a terminal connector

Procedure

1. Twist the cores.
2. Press the terminal opener downward.
3. Insert the wire in the hole.
4. Remove the terminal opener.
5. Pull the wire to confirm that it is secure.

2.3.4 How to change the fuse

Change the fuse in the fuse holder on the power cable according to the input voltage, referring to the following table. Fuses are supplied as spare parts.

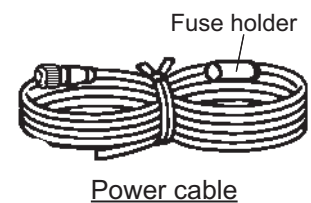

WARNING

! Use the proper fuse.

Fuse rating is shown in the table below. Use of a wrong fuse can result in damage to the equipment.

Input voltage	Rating of fuse
12 VDC	15 A (factory default)
24 VDC	7 A

2.3.5 External switch connection

External switches can be connected to the TB1 terminal in the processor unit to provide one-touch access to a desired menu item or menu. Up to four external switches, each with an individual function, can be connected.

Use a push button switch (momentary contact) for the external switch. For how to assign the function to the external switch, see the operator’s manual.

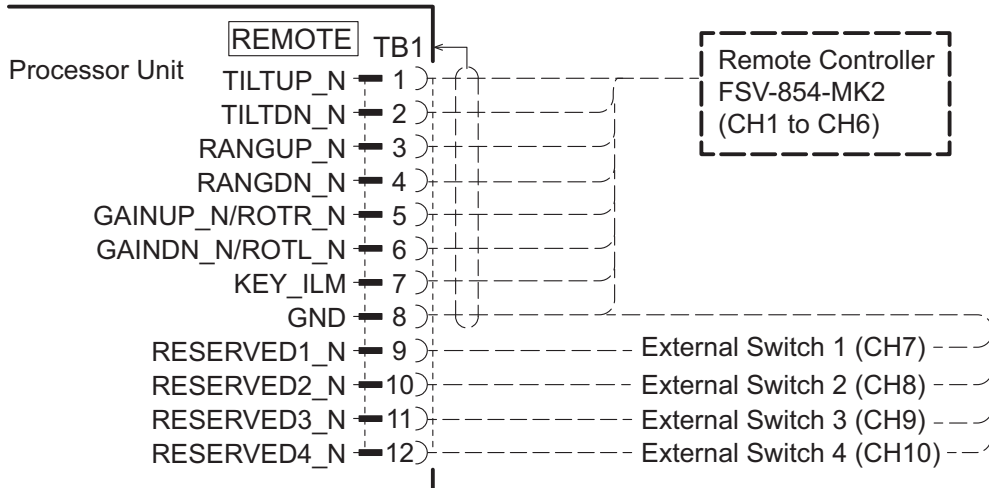

2.3.6 External KP connection

Note: To use the 3D functions, output the KP signal from the transceiver unit to external equipment. If the KP (Keying Pulse) signal is synchronized from external equipment, the 3D function may not work properly.

KP input

To synchronize the KP (Keying Pulse) signal from external equipment, make the connection as follows:

- When the external equipment is a current drive circuit: Use the TB8-1 and TB8-2.
- When the external equipment is a voltage drive circuit: Use the TB8-3 and TB8-4.

The signals for current and voltage drive circuit cannot be used simultaneously.

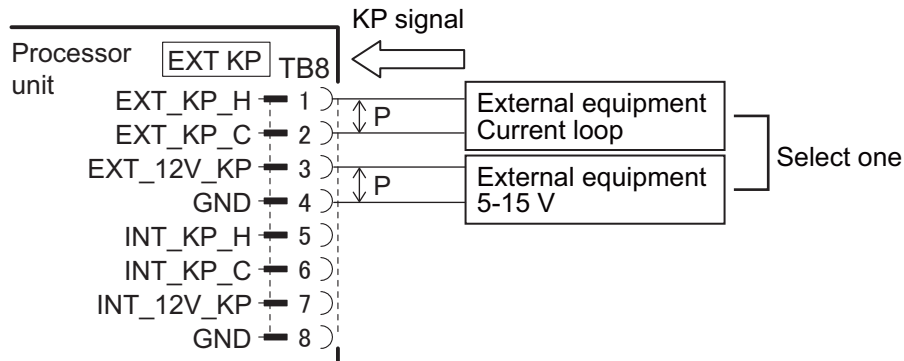

KP output

To output the KP signal from the transceiver unit to external equipment, make the connection as follows:

- When the external equipment is a current drive circuit: Use the TB8-5 and TB8-6.
- When the external equipment is a voltage drive circuit: Use the TB8-7 and TB8-8.

The signals for current and voltage drive circuit can be used simultaneously, for separate destinations.

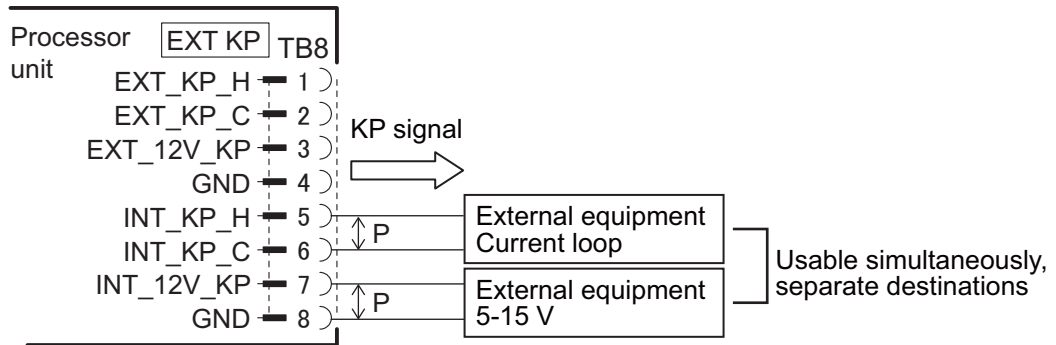

2.4 Control Unit

Connect the control unit to the J1 or J2 terminal in the processor unit.

Ground the control unit, using a ground wire (IV-1.25sq., supplied locally).

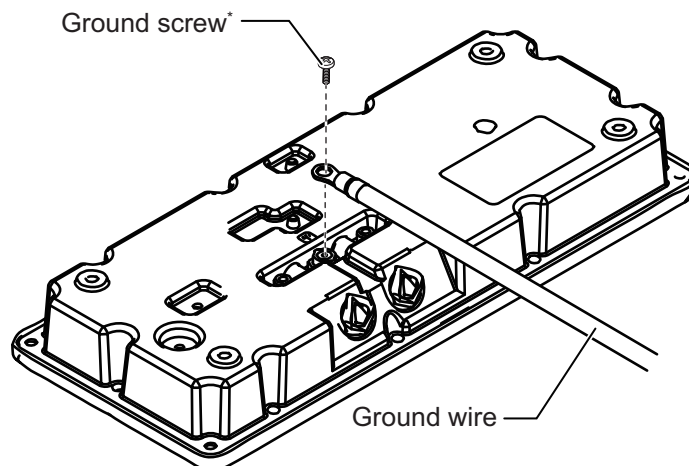

*: Pre-attached to the unit.

2.5 Transceiver Unit

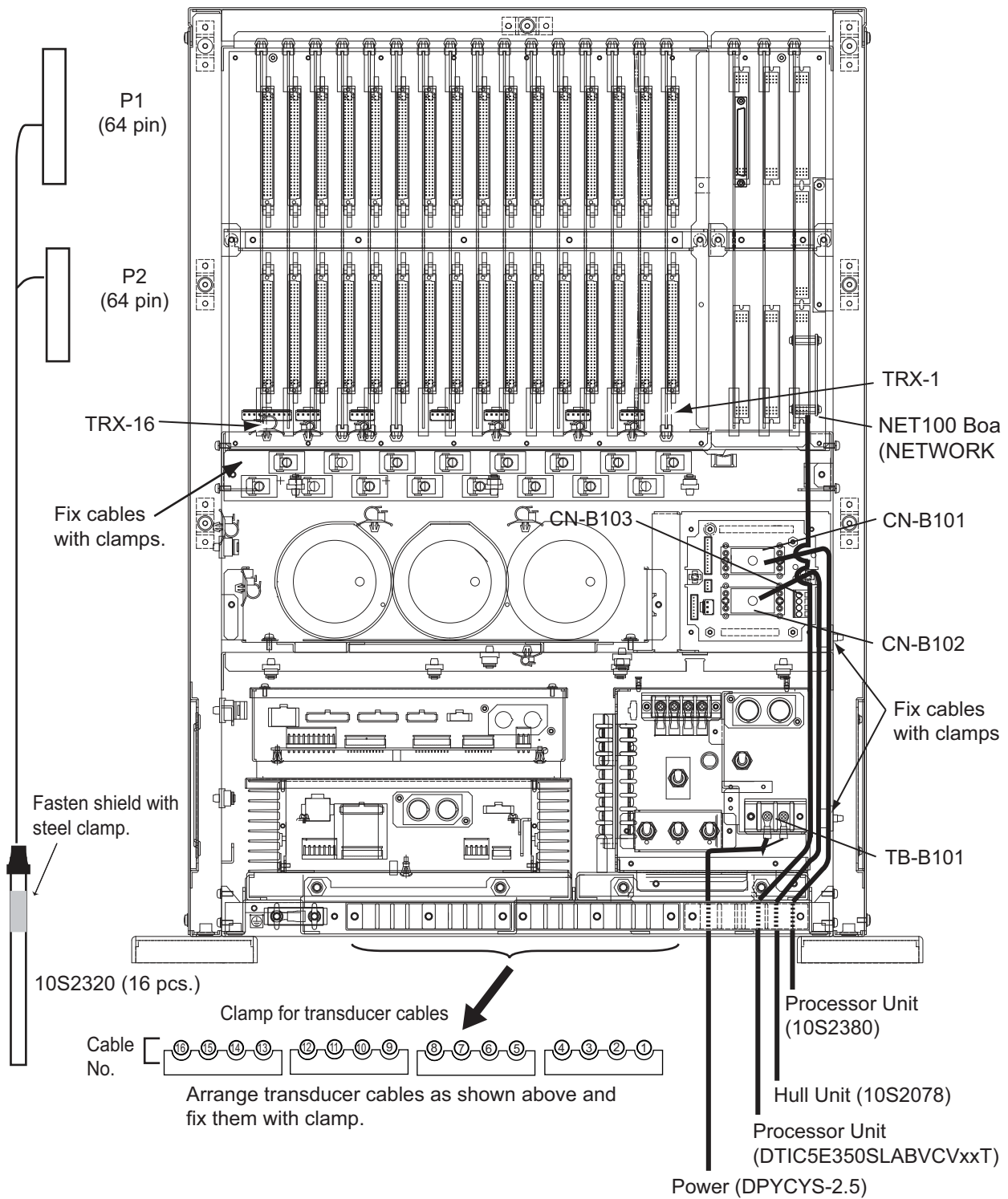

Connect the cables from the transducer referring to cable no. labeled on the chassis and connector no. labeled on each pc board. Connector is locked properly when you hear a “click” sound. For the cable 10S2078 from the control box of the hull unit connect the longer, peeled portion of the cable to the transceiver unit.

Note: To remove or insert a TRX board when the transducer cable is not connected, lock the catch on the transducer cable connector (HIF connector) of that TRX board so that it won't contact the board release tab.

2.5.1 Cable fabrication

10S2380 cable

Fabricate the cable referring to below and connect to CN-B101 passing through the cable clamp of the transceiver unit.

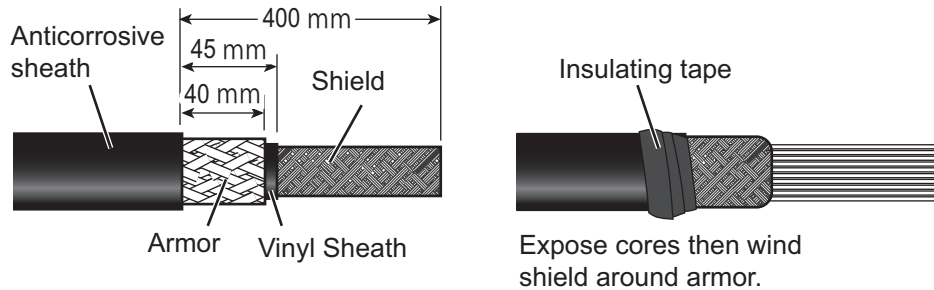

How to fabricate 38P connector

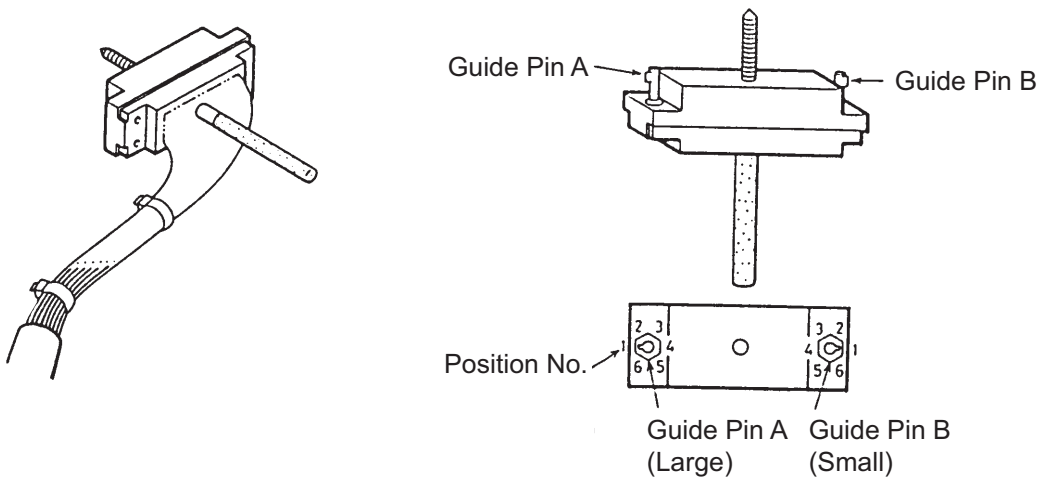

How to assemble 38P connector

Use the guide pin insertion tool (Code No. 10-910-0179-0) to correctly insert guide pins to connectors.

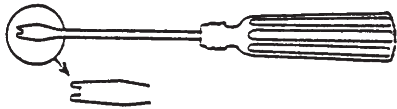
Connector	CN-B101	Tool  (Guide pin insertion tool, notch in head)
Guide pin	1	
Guide pin A (large)	1	
Guide pin B (small)	1	

LAN cable

Fabricate the cable referring to section 2.3.3.

2. WIRING

DPYCYS-2.5 cable

Fabricate the cable as shown in the following figure.

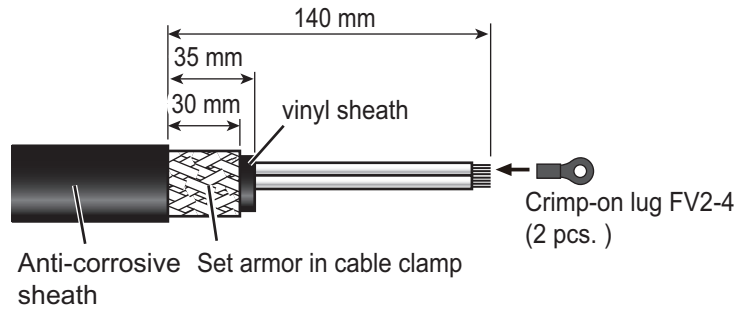

2.5.2 Input Voltage and Fuses

The transceiver unit is shipped from the factory with its input voltage set for 230 VAC and a 10 A fuse inserted in F601 and F602. For other voltages, change toggle switch positions and fuses as shown below.

Input voltage and toggle switch

Input voltage	S603	S604	S605	Default setting
100 VAC	L	L	L	-
110 VAC	H	L	L	-
115 VAC	H	H	L	-
220 VAC	H	L	H	-
230 VAC	H	H	H	Default

Fuses

Change the fuse in F601 and F602 according to input voltage, referring to the table below.

Input Voltage (TB-B101)	F601	F602	Default setting
100 VAC	20A	20A	-
110 VAC			-
115 VAC			-
220 VAC	10A	10A	-
230 VAC			Default



WARNING

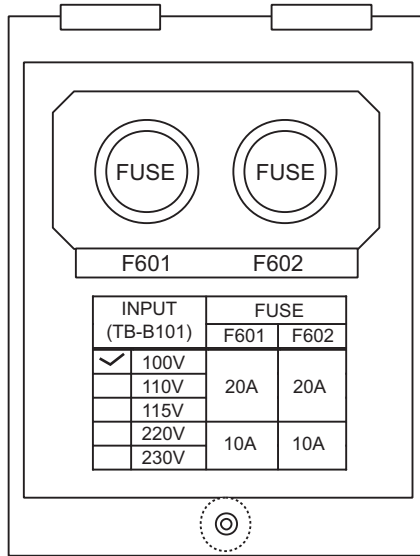

Use the correct fuse.
Use of a wrong fuse can result in damage to the equipment.

How to mark the input voltage label

After setting toggle switches and changing the fuses, mark the label on the inside of the cover with the voltage that applies. In the example shown in the figure to the right, 100 V is checked; 20A fuses are used.

2.6 Raise/Lower Control Box

Connect the 3 phase power cable and the transceiver unit cables (10CA10053 - marked with "Control Unit") as shown below.

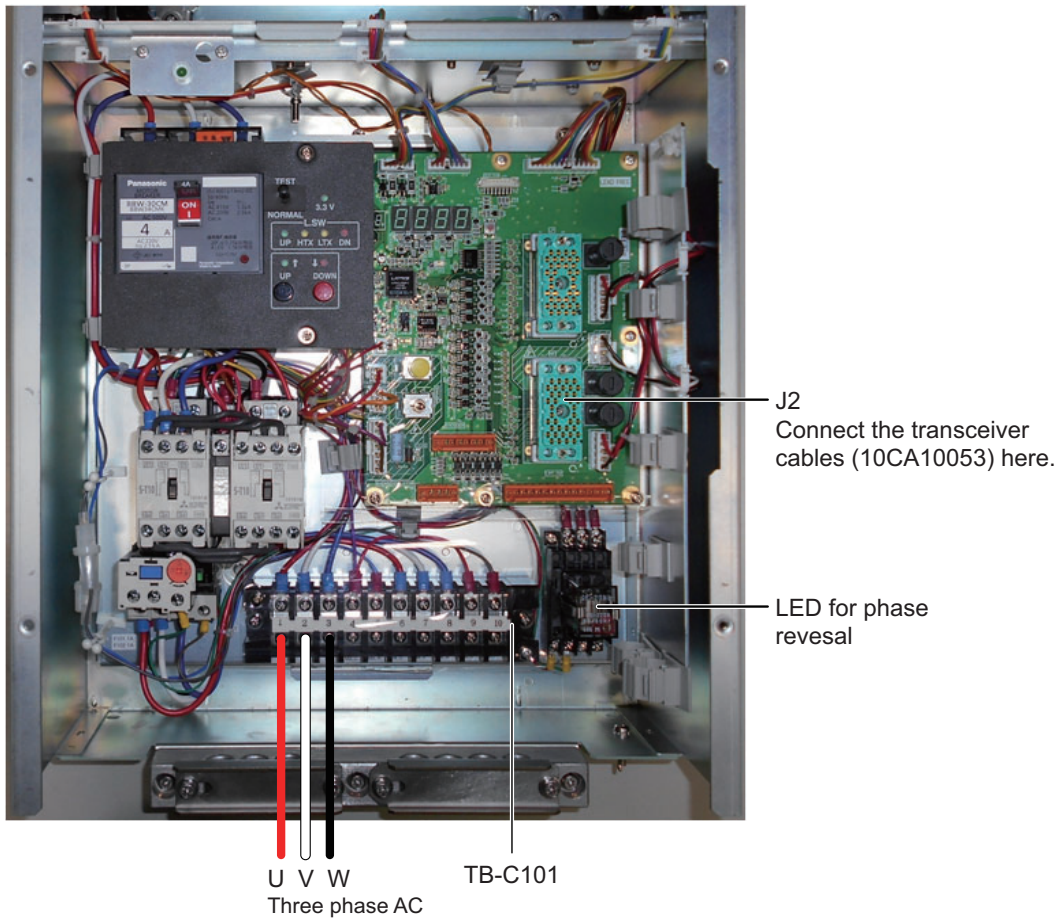

Confirm that the LED lights in red after the wiring is completed. If the LED does not light, turn off power from the mains switchboard, disconnect then reconnect the power cables, turn on the power, and check if the LED lights.

The hull unit does not work when the connection is wrong.

Normal phase: LED lights in red.

Phase reversal: LED does not light.

Fabricate the power cable as shown below.

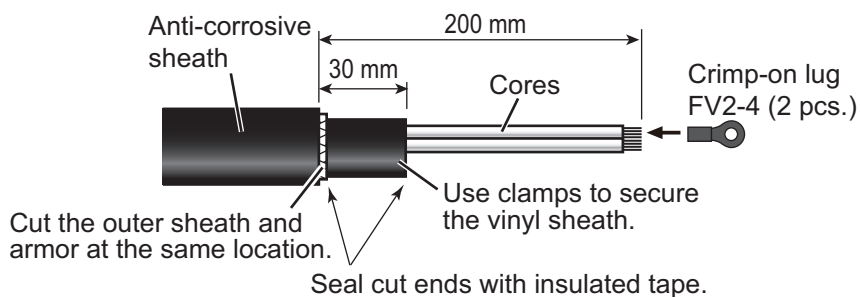

Ground connection

Use a ground wire (IV-8 sq., local supply) to connect to the ship's earth.

Secure the cables in the cable clamp as shown below.

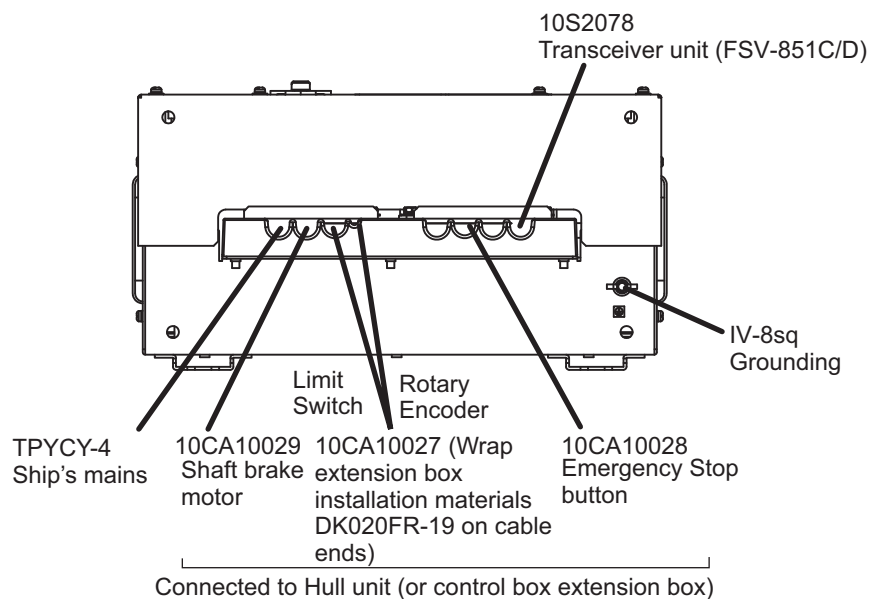

2.7 Control Box Extension Box

The raise/lower control box can be wall mounted up to 5 m away from the hull using the control box extension box.

1. Disconnect the raise/lower control box from the hull unit.
2. Connect the control box extension box to the hull unit, in the same place the raise/lower control box was originally connected.
3. Mount the raise/lower control box on a bulkhead within 5 m of the hull unit.
4. Connect the control box extension box to the raise/lower control box, using the included cables.

Note: When connecting the rotary encoder, limit switch and **EMERGENCY STOP** button to the control box extension box, disconnect the connectors from each cable and replace them with the included crimp-on lugs (See table below for details). Connect the connectors to the control box extension box cables.

See the Interconnection Diagrams at the back of this manual for information on how to wire the raise/lower control box and control box extension box.

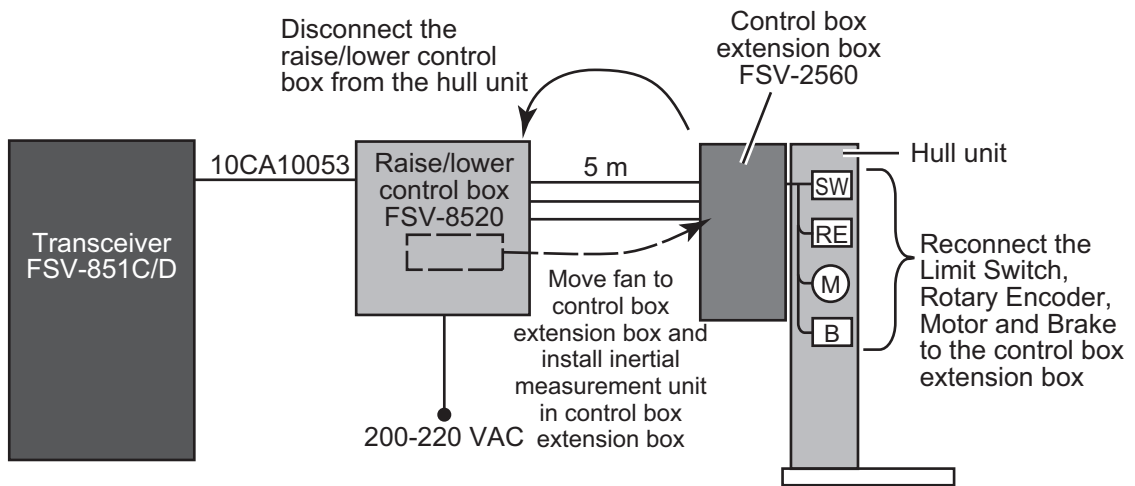

Crimp-on lug cable connections

Crimp-on lug	Cable
FV1.25-3	LMT_SW, Emergency stop button
FV0.5-3	Rotary encoder

Note: The orange line on the emergency stop button, crimp with NCW-1.25 as following figure.

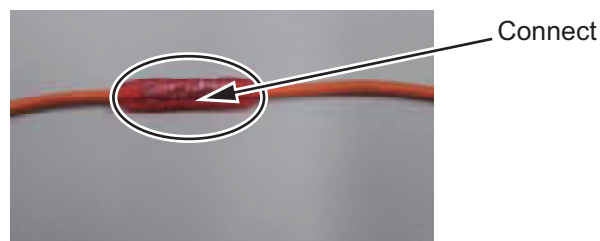

2.7.1 Cable clamp location

Secure all connected cabling in the cable clamp, referring to the following figure.

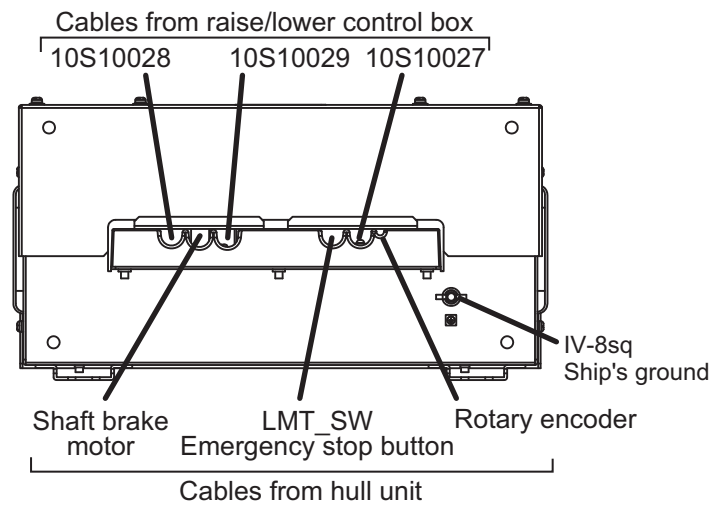

2.7.2 How to connect the fans and inertial measurement unit to the control box extension box

When using the control box extension box, the fans and inertial measurement unit from the raise/lower control box must be installed in the control box extension box. Follow the procedure below.

How to remove the fans and inertial measurement unit from the raise/lower control box

1. Unfasten six screws to remove the front cover.
2. Unfasten four screws to remove the top cover.

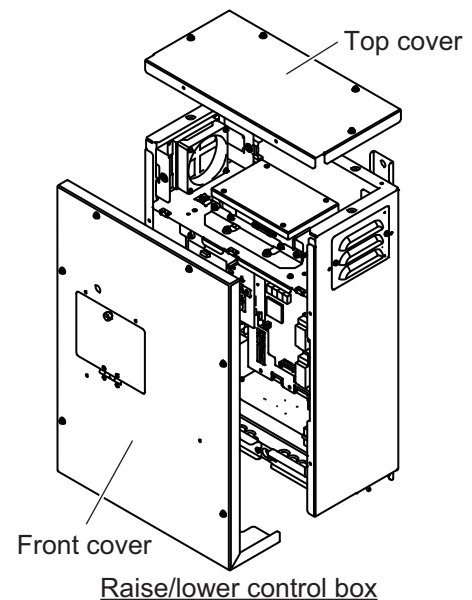

2. WIRING

3. Disconnect the cable from the connector on the inertial measurement unit, then unfasten four screws to remove the unit.

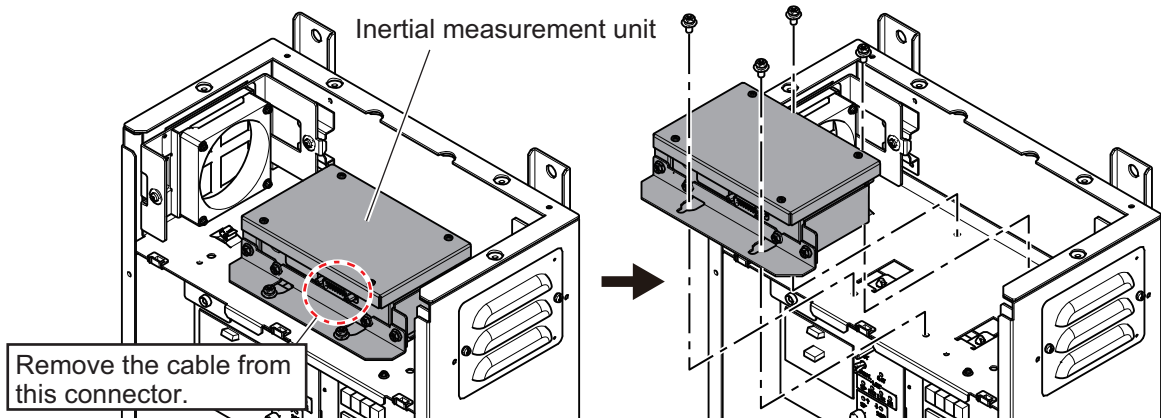

4. Disconnect the fan connectors, then unfasten screws to remove two fans.

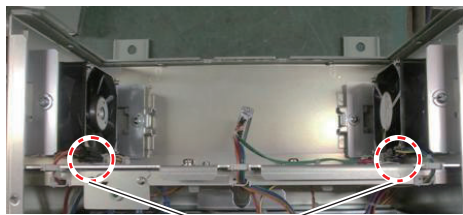

Remove these connectors.

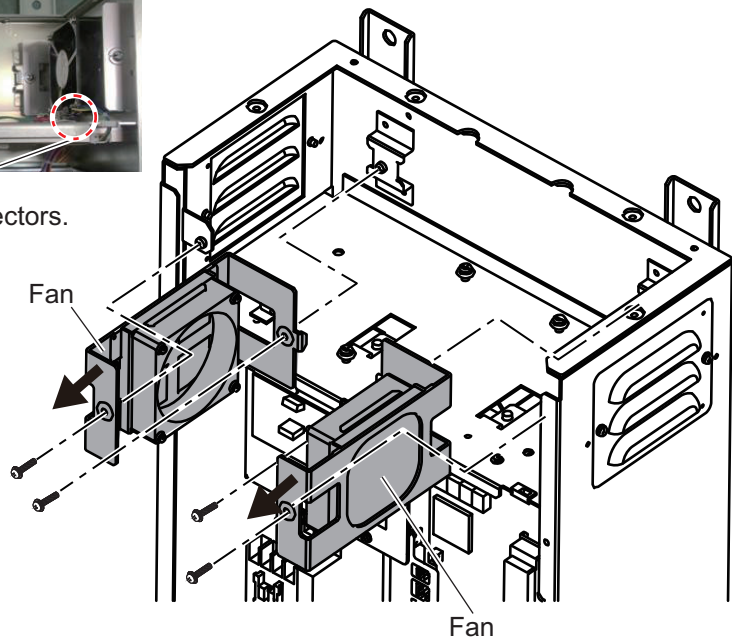

5. Reattach the top cover and front cover.

How to attach the fans and inertial measurement unit to the control box extension box

Note: The inertial measurement unit is extremely shock sensitive, take care not to drop it. Where possible, install the unit after the control box extension box has been installed.

1. Unfasten six screws to remove the front cover.
2. Unfasten four screws to remove the top cover.

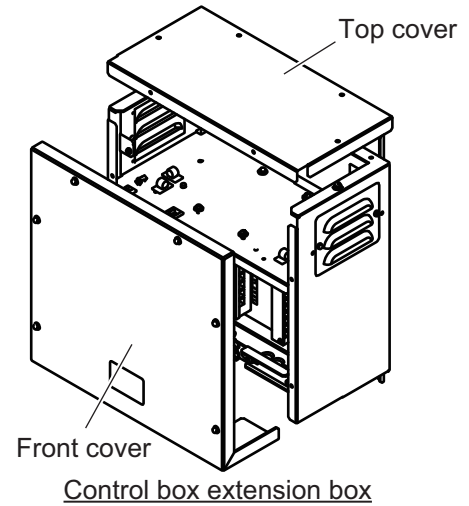

3. Install the fans in the control box extension box, using the four screws to secure them in place.

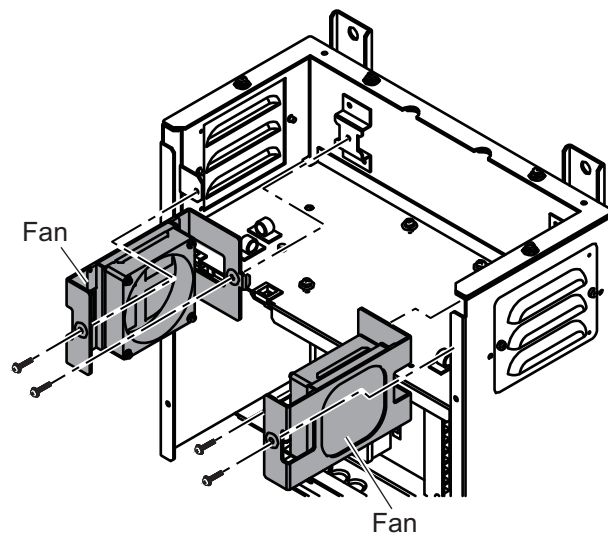
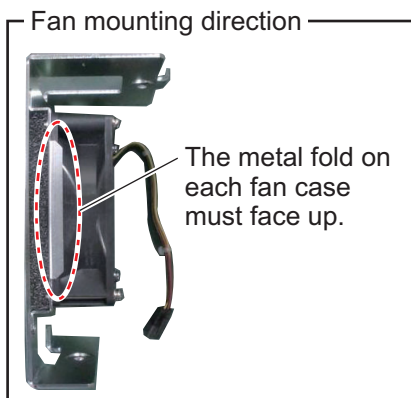

2. WIRING

4. Connect the cables on the fan to the connector inside the control box extension box.

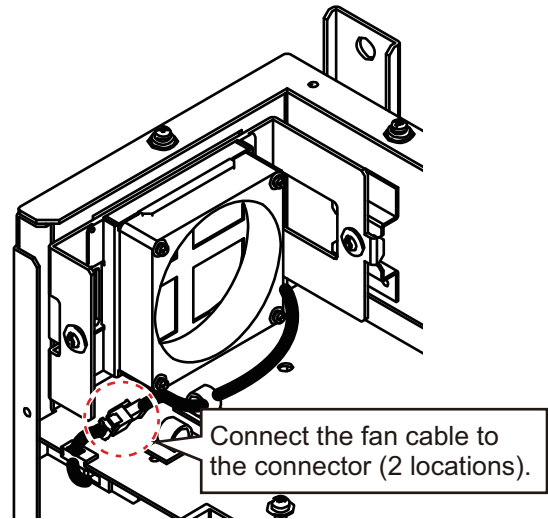

5. Unfasten four screws and set the inertial measurement unit, then fasten the screws to secure it.

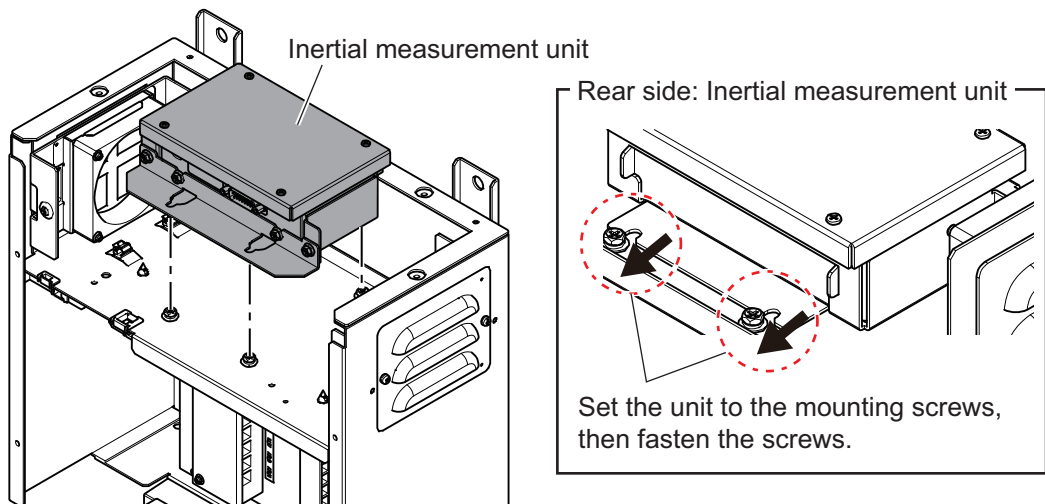

6. Connect the D-SUB connector inside the control box extension box to the inertial measurement unit.

7. Fasten the ground wire (crimp-on lug) of the D-SUB cable to the ground terminal.

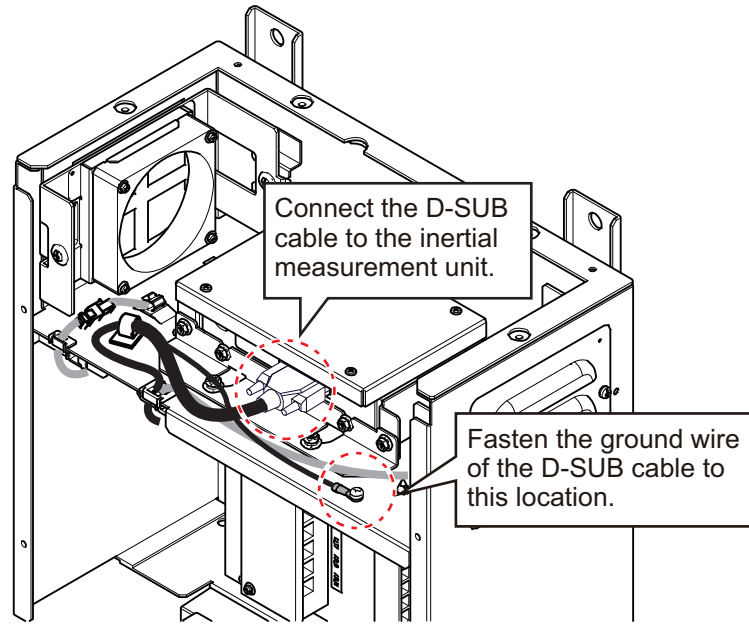

8. Reattach the top cover and front cover.

2. WIRING

This page is intentionally left blank.

3. ADJUSTMENTS AND CHECKS

3.1 How to Access the System Menu

The System menu is used by FURUNO technicians to set up and maintain the unit. This menu should not be accessed otherwise. Use the following procedure to access the system menu items. (System menu items appear to the right of the regular menus).

This section explains the setting procedures for the [OTHERS] system menu.

1. Turn the power to the unit on, then, with no menus displayed on screen, proceed to step 2.
2. While pressing and holding down the **MENU/ESC** key, press **1/F1**, **3/F3**, **5/F5** in order.
3. Release the **MENU/ESC** key.
4. Press the **MENU/ESC** key twice.
5. Select [Others] then left click.

The System menu items are now displayed to the right side of the normal [Others] menu.

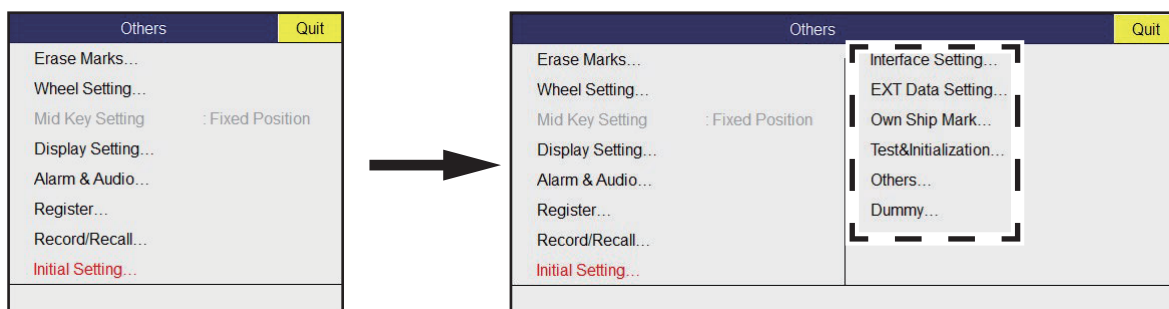

Default "Others" menu

System menu is displayed as part of the "Others" menu

Repeating the above procedure will hide the System menu items.

3.2 How to Change the Displayed Language

The language in which the menus and indications are displayed can be changed. This unit is shipped with the language set to English.

1. Access the System menu. (Refer to section 3.1.)
2. Select [Others] from the System menu items, then left click.
3. Select [Language], then left click.
4. Choose the appropriate language, then left click.
The available choices are English or Japanese.
5. Select [Quit] then left-click.
6. To close all open menus, press and hold the **MENU/ESC** key.

3.3 Selecting Monitor Resolution

Monitor resolution can be selected from below menu.

1. Access the System menu. (Refer to section 3.1.)
2. Select [Others] from the System menu items, then left click.
3. Select [Monitor Resolution] from [Monitor Setting], then left click.

Monitor Setting		Quit
Monitor Orientation	: Horizontal	
2nd Monitor Setting	: OFF	
Monitor Resolution	: SXGA	

4. Left-click [SXGA], [UXGA] or [WUXGA] as applicable.
 - [SXGA]: 1280 × 1024 dots
 - [UXGA]: 1600 × 1200 dots
 - [WUXGA]: 1920 × 1200 dots

Quit
Cancel
SXGA
UXGA
WUXGA

5. Select [Quit] in [Monitor Setting] menu then left click.
6. Turn off and on the power, then the resolution setting is reflected.

Note: After changing the monitor resolution, the size and display position of vertical display will change. Proceed with Monitor Setting as appropriate.

3.4 How to Set Up for Two Monitors

If two monitors are connected, set the display method for the second monitor as follows.

1. At the main menu, select and left-click, in order, [Others], [Initial Setting]. In the pop-up window, select [Changeable].

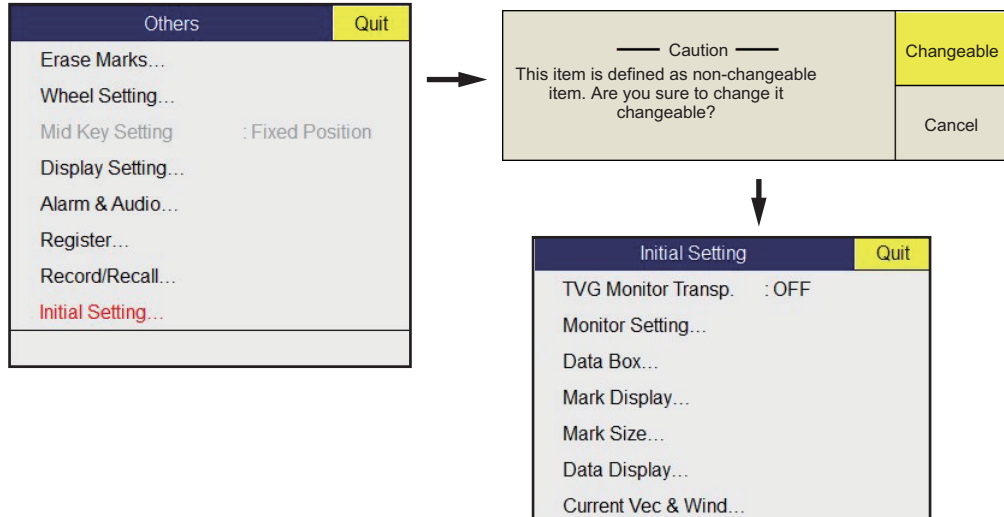

2. Left-click [Monitor Setting].

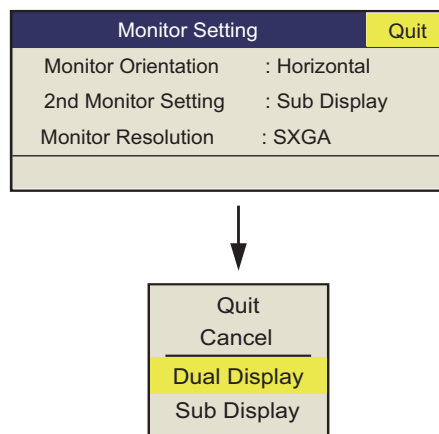

3. Left-click [2nd Monitor Setting].
4. Left-click [Dual Display] or [Sub Display] as applicable.
 - [Dual Display]:** When in dual mode, each display can be assigned as Main or Sub monitor.
 - [Sub Display]:** Displays the same screen as the Main or Sub monitor. When there is no secondary monitor, set this option to [OFF].
5. Select [Quit] then left-click.
6. Close all menu windows, then restart the FSV unit.

3.5 How to Set Up a Vertical Monitor

When using an after market monitor set up in a vertical manner, the monitor settings must be adjusted. Failure to adjust the settings correctly can cause the screen to be displayed upside down.

Ensure the screen has been rotated 90° clockwise from the normal orientation, then do the following:

1. Turn the FSV unit's power on.
2. Press the **MENU/ESC** key to display the main menu.
3. Select and left-click, in order, [Others], [Initial Setting]. In the pop-up window, select [Changeable].

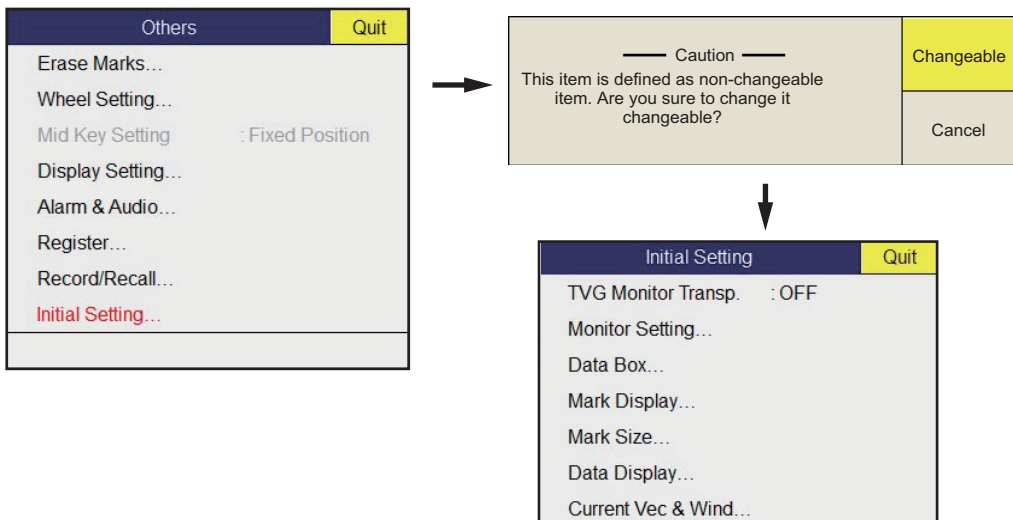

4. Select [Vertical] then left-click.

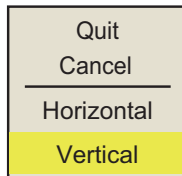

5. Select [Quit] then left-click.
6. Close all menu windows, then restart the FSV unit.

3.6 How to Change the Frequency Setting

The default frequency is 80 kHz. If the sonar frequency is 70 kHz, an alarm sounds and a warning message appears the first time the power is applied after installation. Change to 70 kHz as follows:

1. Turn on the power then press the **R/B AUDIO** key to silence the alarm and erase the message.
2. Access the System menu, referring to section 3.1.

3. Select and left-click, in order, [Others], [Initial Setting]. In the pop-up window, select [Changeable].

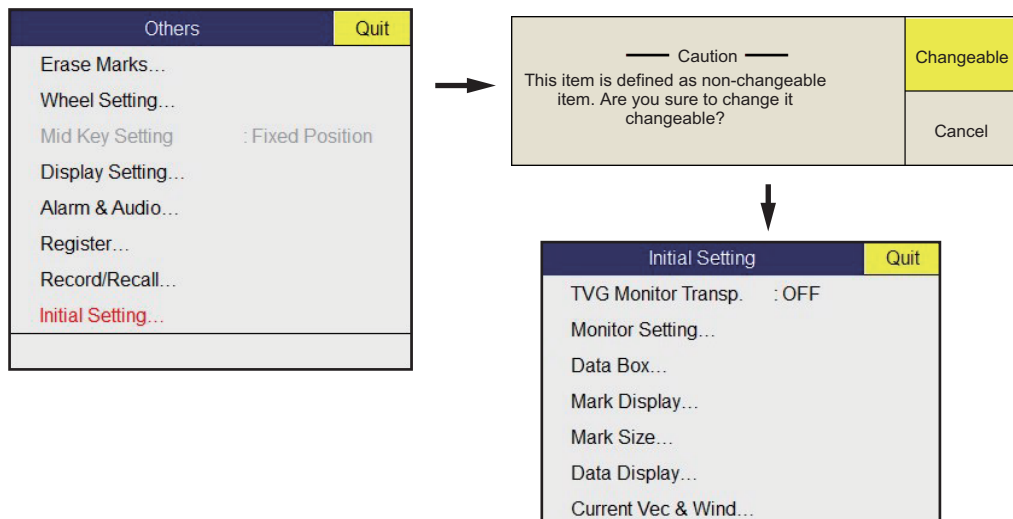

4. Select [Others] from the System menu items, then select [Model], then select [FSV-85-MK-2-70].

3.7 How to Register the Transducer Position

To display the distance which the transducer is protruded, the limit switch location must be entered at the processor unit.

This setting requires the transducer to be protruded from a fully retracted position. Make sure there is sufficient room for full protrusion.

1. Turn the FSV unit's power on.
2. Press the **MENU/ESC** key to display the main menu.
3. Select and left-click, in order, [Others], [Initial Setting]. In the pop-up window, select [Changeable].
4. Select [Hull Unit Setting].
5. Select [REG TD Position].
The following confirmation message appears.
Note: When the transducer position is already registered, the following message appears. To re-register the transducer position, select [Next] the left click.
6. Confirm that transducer is retracted, then select [Next].
7. Confirm that the transducer can be protruded fully, then select [Next].
8. Check the safety and press the **↓** (Full-protrude) key to protrude the transducer.
9. When the transducer is at full protrusion, select [Next].
10. Press the **↑** (Retract) key to retract the transducer.
11. Select [Quit].

3. ADJUSTMENTS AND CHECKS

Note: If transducer registration is aborted for any reason, the following message appears. Select [Quit] to close the message and restart the procedure once safety is ensured.

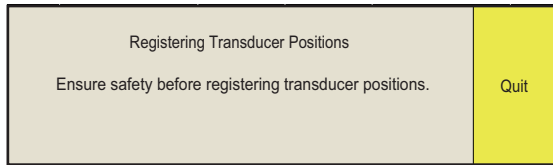

3.8 How to Check the Hull Unit

Do not transmit while doing this procedure.

How to enable transmission

The default transmission state is OFF. Enable transmission as shown in the procedure below. NEVER transmit when the vessel is in dry dock, to prevent damage to the transducer.

1. Turn on the power and press the **MENU/ESC** key to open the menu.
2. Use the trackball to select [Others] then right-click.

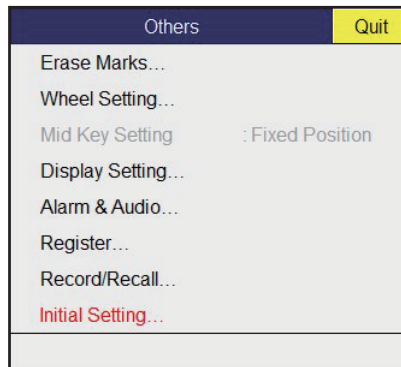

3. Select [Initial Setting] then left-click.

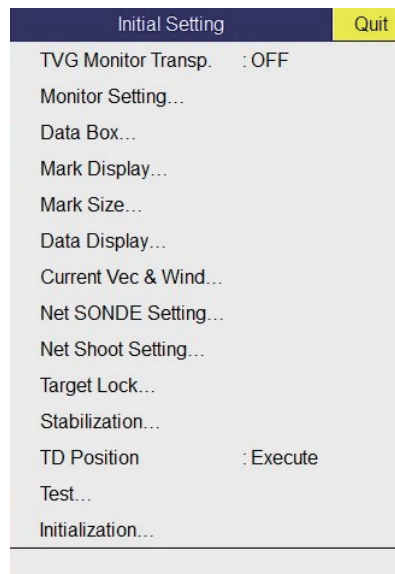

4. Select [Test] then left-click.

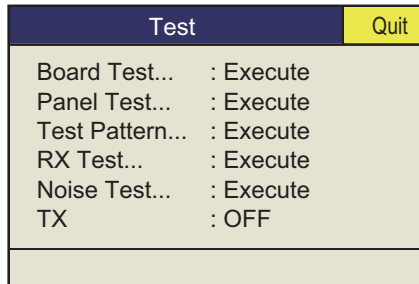

5. Select [TX] then left-click.
6. Select [On] then left-click.
7. Select [Quit] then left-click.
8. Select [Quit] on the topmost menu then left-click.

How to check the hull unit

1. Press the power switch (⏻) on the control unit to turn on the system. Check that both the “ON” LED next to the POWER switch and the ▲ are lit.
2. Confirm that the 3.3V and UP LEDs on the control box are lit.
3. Remove the cover of the control box and use a multimeter to measure the following voltages:

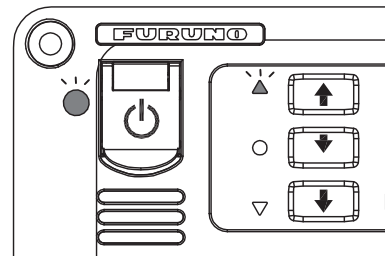

Terminal	Terminal No.	Voltage
TB-C101	(1) - (2) (2) - (3) (1) - (3)	220 VAC 220 VAC 220 VAC

4. In the control box, set the TEST/NORMAL switch to “TEST”. Press the DOWN switch to confirm that the transducer lowers. Also, while the transducer is being lowered, check that the HTX LED lights when the MD L. SW kicks. Note that the MD L. SW does not stop the transducer when the TEST/NORMAL switch is in the TEST position.

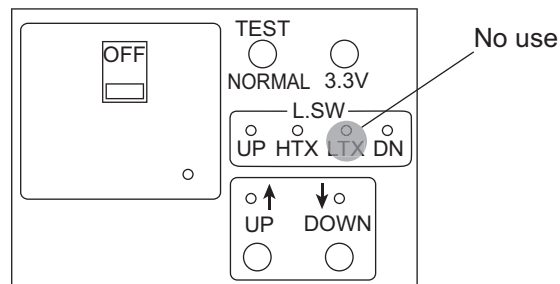

5. Press and release the [DOWN] switch during lowering. Confirm that the transducer stops lowering.
6. Press the DOWN switch again to continue lowering. Confirm that the transducer stops at the moment when the EMERGENCY STOP switch is pressed. After you

3. ADJUSTMENTS AND CHECKS

have confirmed the EMERGENCY STOP switch stops the hull unit lowering, release the EMERGENCY STOP switch by turning the switch clockwise.

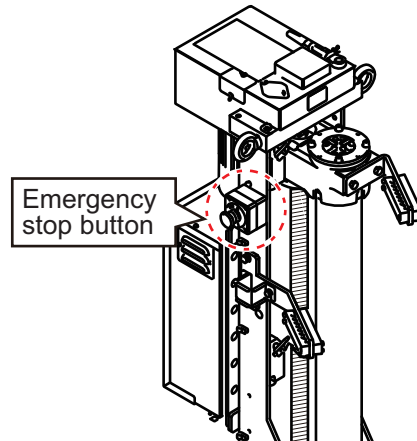

7. Press the DOWN switch again to continue lowering. Confirm that the transducer stops at the moment when the lower limit switch is pressed.
8. Confirm that the [UP] switch operates in a similar manner.
9. Remove the ratchet wrench from its holder on the side of the hull unit. Press the UP switch, then the DOWN switch on the raise/lower control box to make sure the hull unit does not move. Once you have confirmed there is no movement in the hull unit, place the ratchet wrench back in its holder.

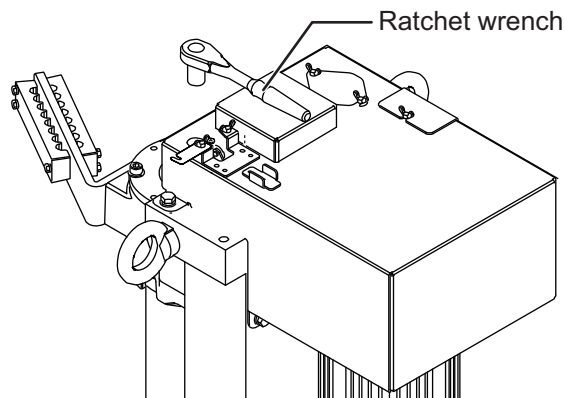

10. Check that LEDs on the panel of the control box light as follows:
 - 1) The UP, HTX and DN LEDs light when corresponding limit switch is kicked.
 - 2) The UP and DN LEDs light while UP and DOWN switches are pressed and extinguish when the switches are released.
11. Set the TEST/NORMAL switch to "NORMAL".
12. Check that the transducer is fully retracted. At the control unit, press the ▼ (mid-protrusion position) switch. Confirm that the LED above the switch blinks while the transducer is being lowered, a short beep sounds when the mid limit switch kicks, and the LED lights when the transducer stops at the mid position.
13. Press the ▼ switch (fully lowered position) and then the ▲ switch. Confirm that the LED above the respective switch blinks while the transducer is being lowered or raised, and a short beep sounds when the lower or upper limit switch is kicked, and the LED lights when the transducer is fully lowered or raised.
14. Press the OFF switch. Confirm that the transducer is completely retracted and the power is off.

15. With the transducer lowered (mid or fully lowered), confirm that the transducer is raised when the  switch or the OFF switch is pressed.

3.9 How to Adjust the Heading

Heading correction at the hull unit

When the BOW mark on the flange of the hull unit cannot be directed toward ship's bow, adjust the heading so an echo which is dead ahead appears dead ahead on the display.

1. Enable transmission as shown in section 3.8.
2. Find a target in the bow direction (buoy, for example) and display it on a near range perfectly. If the target appears at 12 o'clock the heading alignment is correct. If it does not, measure the error and go to next step.

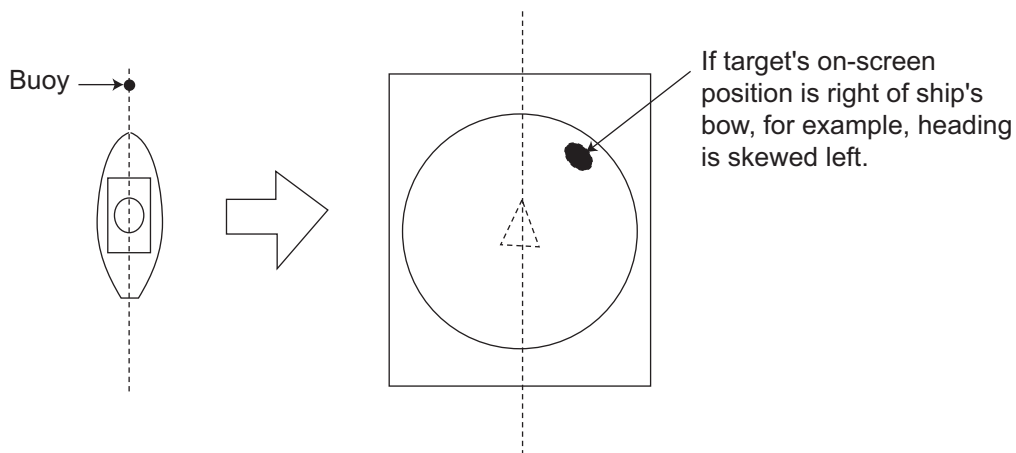

3. If the heading is skewed, measure the skew angle.
4. Access the System menu, referring to section 3.1.
5. Select [Others] from the System menu items, then left-click.
6. Select [Heading Adjust 1] then left-click.
7. Rotate the scrollwheel to enter the angle measured at step 3. The setting range is -180° to 179° , in one-degree increments.
8. Select [Quit] then left-click.
9. Select [Heading Adjust 2] then left-click.
10. Rotate the scrollwheel to enter the angle measured at step 3. The setting range is -180° to 179° , in one-degree increments.
11. Select [Quit] then left-click.
12. Select Quit on the topmost menu then left-click.

3.10 How to Configure the Own Ship Mark

Set your ship's length and width and the position of the transducer, to accurately display the own ship mark on the screen.

1. Access the System menu, referring to section 3.1.
2. Select [Own Ship Mark] then left-click.
3. Select [Ship's Length] then left-click.
4. Use the scrollwheel to set length. The setting range is 15 to 150 m.
5. Set ship's width and transducer positions similarly.

- [Ship's Width]: The width of the ship at its widest point. (Setting range: 5 to 30 m)
- [TD Position 1]: Distance from transducer to bow. (Setting range: 5 to 50 m)
- [TD Position 2]: Distance from transducer to keel. Select "+" for starboard, "-" for port. (Setting range: -10 to 10m)

6. Long-press the **MENU/ESC** key to close all menus.

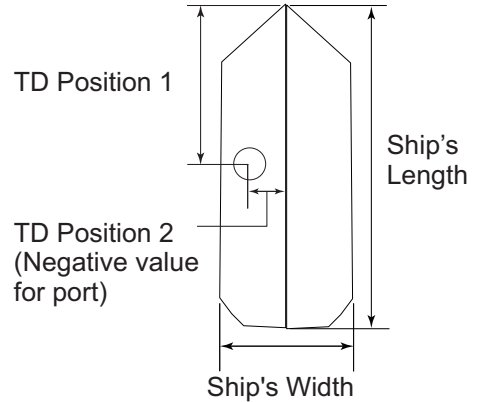

3.11 Others Menu

The [Others] menu sets the equipment according to the external equipment connected.

3.11.1 Interface Setting menu

NMEA1 to 5 Baud Rate: Set the transmission rate for the NMEA 1 to NMEA 5 ports. (4800 bps, 9600 bps, 19200 bps, 38400 bps)

EXT KP Input: Set the input logic of KP from external equipment. (Disable, Enable)
Disable: Disable external KP. Enable: Use KP from external equipment.

3.11.2 EXT Data Setting menu

Date&Time: Select the input format for date and time data. (Disable, NMEA)

Heading: Select the input format for heading data. (Disable, AD10, NMEA)

Speed&Course: Select the input format for ship's speed and course data. (Disable, NMEA (SOG), NMEA (STW))

Speed Sensor: Select the input format for speed data. (Disable, GPS/DR, DOPPLER/DR) If response is slow, select GPS.

Lat/Lon: Select the input format for position data. (Disable, NMEA)

Water Depth: Select the input format for water depth. (Disable, NMEA)

Water Temp: Select the input format for water temperature. (Disable, NMEA)

Water Current: Select the input format for water current. (Disable, NMEA)

Wind: Select the input format for wind data. (Disable, NMEA)

Net Depth: Select the input format for net depth data. (Disable, NMEA)

3.11.3 Others menu

Language: Select the language to use. (English, Japanese, Chinese)

Trackball Speed: Select the tracking speed for the trackball. (Slow, Normal, Fast)

Hull Unit Stroke: Select the stroke of the hull unit. (800 mm, 1100 mm)

Noise Meas. Freq: Select the frequency for which to measure noise. Two settings are available, but keep the default setting. Meas. Freq1: 80 kHz: 95 - 145, 70 kHz: 130 - 260 Meas. Freq2: 80 kHz: -145 to -95, 70 kHz: -130 to -110

3. ADJUSTMENTS AND CHECKS

Propeller Supp. items:

Propeller Supp.: Turn the propeller noise suppressor on or off. The setting range is 0 - 13. 0 is OFF. The higher the number the greater the suppression.

Propeller Tilt: Keep the initial setting (0). When [Propeller Supp] above is set to 0, this item appears in gray.

Propeller Dir. : Set the bearing of the propeller as viewed from the transducer position, to set the bearing at which propeller noise is suppressed. The setting range is -180° to 179°.

Exclus. Apt Len: Keep the initial setting (0).

Error Code List: Confirm error codes.

Explorer: Confirm and search files.

APPENDIX 1 JIS CABLE GUIDE

Cables listed in the manual are usually shown as Japanese Industrial Standard (JIS). Use the following guide to locate an equivalent cable locally.

JIS cable names may have up to 6 alphabetical characters, followed by a dash and a numerical value (example: DPYC-2.5).

For core types D and T, the numerical designation indicates the *cross-sectional Area (mm²)* of the core wire(s) in the cable.

For core types M and TT, the numerical designation indicates the *number of core wires* in the cable.

1. Core Type

D: Double core power line

T: Triple core power line

M: Multi core

TT: Twisted pair communications
(1Q=quad cable)

2. Insulation Type

P: Ethylene Propylene Rubber

3. Sheath Type

Y: PVC (Vinyl)

4. Armor Type

C: Steel

5. Sheath Type

Y: Anticorrosive vinyl sheath

6. Shielding Type

SLA: All cores in one shield, plastic tape w/aluminum tape

-SLA: Individually shielded cores, plastic tape w/aluminum tape



EX: ¹ ³ ⁴ ⁵ ⁶ TTYCYSLA - 4
 Designation type | # of twisted pairs

¹ ² ³ ⁴ MPYC - 4
 Designation type | # of cores

The following reference table lists gives the measurements of JIS cables commonly used with Furuno products:

Type	Area	Core Diameter	Cable Diameter	Type	Area	Core Diameter	Cable Diameter
DPYC-1.5	1.5mm ²	1.56mm	11.7mm	TTYCSLA-1	0.75mm ²	1.11mm	9.4mm
DPYC-2.5	2.5mm ²	2.01mm	12.8mm	TTYCSLA-1T	0.75mm ²	1.11mm	10.1mm
DPYC-4	4.0mm ²	2.55mm	13.9mm	TTYCSLA-1Q	0.75mm ²	1.11mm	10.8mm
DPYC-6	6.0mm ²	3.12mm	15.2mm	TTYCSLA-4	0.75mm ²	1.11mm	15.7mm
DPYC-10	10.0mm ²	4.05mm	17.1mm	TTYCY-1	0.75mm ²	1.11mm	11.0mm
DPYCY-1.5	1.5mm ²	1.56mm	13.7mm	TTYCY-1T	0.75mm ²	1.11mm	11.7mm
DPYCY-2.5	2.5mm ²	2.01mm	14.8mm	TTYCY-1Q	0.75mm ²	1.11mm	12.6mm
DPYCY-4	4.0mm ²	2.55mm	15.9mm	TTYCY-4	0.75mm ²	1.11mm	17.7mm
MPYC-2	1.0mm ²	1.29mm	10.0mm	TTYCY-4SLA	0.75mm ²	1.11mm	19.5mm
MPYC-4	1.0mm ²	1.29mm	11.2mm	TTYCYSLA-1	0.75mm ²	1.11mm	11.2mm
MPYC-7	1.0mm ²	1.29mm	13.2mm	TTYCYSLA-4	0.75mm ²	1.11mm	17.9mm
MPYC-12	1.0mm ²	1.29mm	16.8mm	TTPYCSLA-1	0.75mm ²	1.11mm	9.2mm
TPYC-1.5	1.5mm ²	1.56mm	12.5mm	TTPYCSLA-1T	0.75mm ²	1.11mm	9.8mm
TPYC-2.5	2.5mm ²	2.01mm	13.5mm	TTPYCSLA-1Q	0.75mm ²	1.11mm	10.5mm
TPYC-4	4.0mm ²	2.55mm	14.7mm	TTPYCSLA-4	0.75mm ²	1.11mm	15.3mm
TPYCY-1.5	1.5mm ²	1.56mm	14.5mm				
TPYCY-2.5	2.5mm ²	2.01mm	15.5mm				
TPYCY-4	4.0mm ²	2.55mm	16.9mm				

APPENDIX 2 INSTALLATION CHECK LIST

After completing the installation, perform the following checks:

Check point		Reference	Result
Hardware installation check			
Sonar oil	The dome is filled with the sonar oil.	section 1.8	<input type="checkbox"/>
O-ring in the retraction tank flange	O-ring is attached to the retraction tank flange.	section 1.1.3	<input type="checkbox"/>
O-ring in the retraction tank flange (when the attachment kit is used)	O-ring, gasket and insulation packing are attached to the retraction tank flange.	section 1.7	<input type="checkbox"/>
Waterproofing Gasket in the retraction tank flange (when OP10-29 is used)	Waterproofing Gasket is attached to the retraction tank flange.	section 1.9	<input type="checkbox"/>
Bow mark direction of the transducer	Confirm that the bow mark on the transducer faces the bow direction.	section 1.1.3	<input type="checkbox"/>
Input voltage toggle switch on the transceiver unit	Input voltage toggle switches on the transceiver unit are changed correctly, depending on the input voltage.	section 2.5.2	<input type="checkbox"/>
Vibration and sound while raising/lowering the transducer	Confirm that abnormal vibration or noise is not generated from the hull unit while raising/lowering the transducer.	-	<input type="checkbox"/>
Software setting check			
Language setting	The language in which the menus and indications is changed as necessary.	section 3.2	<input type="checkbox"/>
Transducer position registration	The transducer position registration is completed.	section 3.7	<input type="checkbox"/>
Turn the transmission on	Change the transmission status from [OFF] to [ON].	section 3.8	<input type="checkbox"/>
Heading Correction	Adjust the heading so an echo which is dead ahead appears dead ahead on the display.	section 3.9	<input type="checkbox"/>
Direction offset of the motion sensor	Offset the direction difference between the [Reference Direction] mark on the motion sensor and bow direction.	section 3.9	<input type="checkbox"/>
Stroke setting	Select 800 mm or 1100 mm according to the stroke (length) of your hull unit.	section 3.11.3	<input type="checkbox"/>
External data setting	Set the baud rate for the NMEA2000 port and select the input format for external data.	section 3.11.1/ section 3.11.2	<input type="checkbox"/>
System time setting	Set the system time and time zone.	Operator's manual	<input type="checkbox"/>
Continued of following page			



Check point		Reference	Result
Save ship's original setting	Save all menu settings in the internal memory as necessary.	Operator's manual	<input type="checkbox"/>
Display setting for the numeric/graphic data display	Change the display setting for the numeric/graphic data display as appropriate.	Operator's manual	<input type="checkbox"/>
Function key setting	Assign the function to the function keys as necessary.	Operator's manual	<input type="checkbox"/>
Preset the horizontal mode ranges	Preset the horizontal mode ranges as selected with the RANGE control as necessary.	Operator's manual	<input type="checkbox"/>

PACKING LIST

FSV-8501-MK2

10CV-X-9866 -0 1/1

A-1

NAME	OUTLINE	DESCRIPTION/CODE No.	Q'TY
ユニット			
制御部 CONTROL UNIT		FSV-8501-MK2-* 000-038-291-00 **	1
工事材料			
KB取付金具 KB FIXTURE ASSEMBLY		CP03-3320Z 001-115-510-00	1
工事材料 INSTALLATION MATERIALS		CP10-09601 001-537-900-00	1

コード番号末尾の[*]**は、選用品の代表コードを表します。
CODE NUMBER ENDING WITH * ** INDICATES THE CODE NUMBER OF REPRESENTATIVE MATERIAL.

(略図の寸法は、参考値です。DIMENSIONS IN DRAWING FOR REFERENCE ONLY.)





C1367-Z01-A

PACKING LIST

FSV-8503-MK2

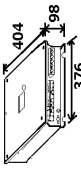
10CV-X-9867 -0 1/1

A-2

NAME	OUTLINE	DESCRIPTION/CODE No.	Q'TY
ユニット			
制御部 PROCESSOR UNIT		FSV-8503-MK2 000-038-293-00	1
予備品			
予備品 SPARE PARTS		SP26-00301 001-080-860-00	1
工事材料			
ケーブル組品組 CABLE ASSY.		MJ-A3SPF0018-050ZC 001-597-190-00	1
工事材料 INSTALLATION MATERIALS		CP10-09701 001-538-140-00	1
図書			
ヒューズ交換要領 FUSE REPLACEMENT GUIDE		C12-01903-* 000-197-190-1*	1

(略図の寸法は、参考値です。DIMENSIONS IN DRAWING FOR REFERENCE ONLY.)





C1367-Z02-A

PACKING LIST

10CV-X-9868 -0 1/1

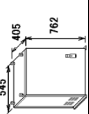
FSV-851C/D-MK2-*

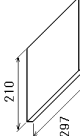
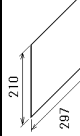
A-3

NAME	OUTLINE	DESCRIPTION/CODE No.	Q'TY
ユニット			
送受信装置 TRANSCIVER UNIT		FSV-851*-MK2-* 000-038-302-00 **	1
予備品			
予備品 SPARE PARTS		SP10-03101 007-008-530-00	1
工事材料			
INSTALLATION MATERIALS			
取説説明書 OPERATOR'S MANUAL		CP10-07011 001-005-660-00	1
図書 DOCUMENT			
取説説明書 OPERATOR'S MANUAL		OM*-13670-* 000-198-902-1* **	1
整備要領書 INSTALLATION MANUAL		IM*-13670-* 000-198-904-1* **	1
電源設定書 INPUT VOLTAGE SETTING		C12-00602-* 000-162-177-1*	1

コード番号末尾の[*]**は、選択品の代表コードを表します。
CODE NUMBER ENDING WITH * ** INDICATES THE CODE NUMBER OF REPRESENTATIVE MATERIAL.

(*1)の現地組部品は仕様により選択願います。
(*1) CHOOSE ONE ACCORDING TO SPECIFICATION.

(略図の寸法は、参考値です。 DIMENSIONS IN DRAWING FOR REFERENCE ONLY.)





C1367-Z03-A

PACKING LIST

10CV-X-9869 -0 1/1

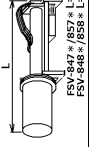
FSV-847*/848*/857*/858*-MK2-T

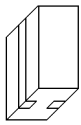
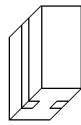
A-4

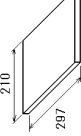
NAME	OUTLINE	DESCRIPTION/CODE No.	Q'TY
ユニット			
上下装置 HULL UNIT		FSV-847*/848*/857*/858*-T 000-038-333-00 **	1
予備品			
予備品 SPARE PARTS		SP10-04201 001-269-280-00	1
現地組部品			
LOCAL ASSEMBLING PARTS			
現地組部品箱詰 LOCAL ASSEMBLY PARTS COMPLETE SET		FSV-85/85L-D-T 001-520-120-00	1 (*1)
現地組部品箱詰 LOCAL ASSEMBLY PARTS COMPLETE SET		FSV-85/85L-T 001-520-130-00	1 (*1)
工事材料			
INSTALLATION MATERIALS			
工事材料 INSTALLATION MATERIALS		CP10-08101 001-269-290-00	1
図書			
図書 DOCUMENT			
整備要領書 INSTALLATION MANUAL		IM*-13670-* 000-198-904-1* **	1

コード番号末尾の[*]**は、選択品の代表コードを表します。
CODE NUMBER ENDING WITH * ** INDICATES THE CODE NUMBER OF REPRESENTATIVE MATERIAL.

(*1)の現地組部品は仕様により選択願います。
(*1) CHOOSE ONE ACCORDING TO SPECIFICATION.

(略図の寸法は、参考値です。 DIMENSIONS IN DRAWING FOR REFERENCE ONLY.)





C1367-Z04-A

PACKING LIST

100V-X-9870 -0 1/1

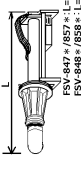
FSV-847*/848*/857*/858*-MK2-N

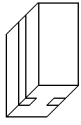
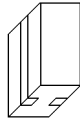
A-5

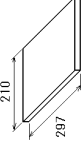
NAME	OUTLINE	DESCRIPTION/CODE No.	Q'TY
ユニット			
上下装置 HULL UNIT	 FSV-847*/857*/L=2089 FSV-848*/858*/L=2389	FSV-847*/848*/857*/858*-N 000-038-336-00 **	1
予備品			
予備品 SPARE PARTS		SP10-04201 001-269-280-00	1
現地組品			
LOCAL ASSEMBLING PARTS			
現地組品箱詰 LOCAL ASSEMBLY PARTS COMPLETE SET		FSV-85/85L 001-520-110-00	1 (*1)
現地組品箱詰 LOCAL ASSEMBLY PARTS COMPLETE SET		FSV-85/85L-D 001-520-100-00	1 (*1)
工事材料			
INSTALLATION MATERIALS			
工事材料 INSTALLATION MATERIALS		CP10-08101 001-269-290-00	1
図書			
装備要領書 INSTALLATION MANUAL		IM*-13670-* 000-198-904-1* **	1

コード番号末尾の[*1]は、選択品の代表コードを表します。
CODE NUMBER ENDING WITH '*1' INDICATES THE CODE NUMBER OF REPRESENTATIVE MATERIAL.
(*1)の現地組品は仕様により選択願います。
(*1) CHOOSE ONE ACCORDING TO SPECIFICATION.

(略図の寸法は、参考値です。 DIMENSIONS IN DRAWING FOR REFERENCE ONLY.)



C1367-Z05-A

PACKING LIST

100V-X-9872 -0 1/1

FSV-854-MK2-E*

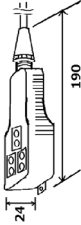
A-6

NAME	OUTLINE	DESCRIPTION/CODE No.	Q'TY
ユニット			
リモコン REMOTE CONTROLLER		FSV-854-MK2-E* 000-038-341-00 **	1
工事材料			
INSTALLATION MATERIALS			
工事材料 INSTALLATION MATERIALS		CP10-04200 006-027-250-00	1

コード番号末尾の[*1]は、選択品の代表コードを表します。
CODE NUMBER ENDING WITH '*1' INDICATES THE CODE NUMBER OF REPRESENTATIVE MATERIAL.

(略図の寸法は、参考値です。 DIMENSIONS IN DRAWING FOR REFERENCE ONLY.)

C1367-Z07-A





PACKING LIST

FSV-2560

10CV-X-9891 -1

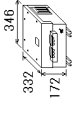
1/1

A-7

N A M E	O U T L I N E	D E S C R I P T I O N / C O D E N o.	Q ' T Y
ユニット			
制御器延長箱		FSV-2560	1
CONTROL BOX EXTENSION BOX		000-025-106-00	
工事材料			
INSTALLATION MATERIALS			
ケーブル(組品)		CP10-08000	
CABLE ASSEMBLY	 L=5M	10CA10027	1
ケーブル(組品)		000-178-749-10	
CABLE ASSEMBLY	 L=5M	10CA10028	1
ケーブル(組品)		000-178-750-10	
CABLE ASSEMBLY	 L=5M	10CA10029	1
ケーブル(組品)		000-178-751-11	
CABLE ASSEMBLY		CP10-08001	1
工事材料		001-269-660-00	
INSTALLATION MATERIALS			
INSTALLATION MATERIALS			

(略図の寸法は、参考値です。 DIMENSIONS IN DRAWING FOR REFERENCE ONLY.)

C1344-Z19-B



PACKING LIST

FSV-853

10CV-X-9856 -0

1/1

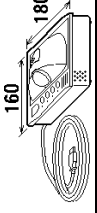
A-8

N A M E	O U T L I N E	D E S C R I P T I O N / C O D E N o.	Q ' T Y
ユニット			
簡易操作部		FSV-853	1
CONTROL UNIT		000-019-213-00	
工事材料			
INSTALLATION MATERIALS			
工事材料		CP10-07501	1
INSTALLATION MATERIALS		001-135-210-00	

型式/コード番号が2段の場合、下段より上段に代わる過渡期品であり、どちらかが入っています。 なお、品質は変わりません。
TWO TYPES AND CODES MAY BE LISTED FOR AN ITEM. THE LOWER PRODUCT MAY BE SHIPPED IN PLACE OF THE UPPER PRODUCT. QUALITY IS THE SAME.

(略図の寸法は、参考値です。 DIMENSIONS IN DRAWING FOR REFERENCE ONLY.)

C1335-Z06-A

FURUNO

CODE NO.	001-115-510-00	03HE-X-9407-0	1/1
TYPE	CP03-33202		

工事材料表

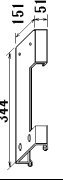
INSTALLATION MATERIALS			
番号 NO.	名称 NAME	略図 OUTLINE	数量 QTY
1	KB取付金具 KB FIXTURE	ROU-021, FSV-8501 344 	1
		型名/規格 DESCRIPTIONS 03-177-2201-0 CODE NO. 100-355-860-10	用途/備考 REMARKS

型式/コード番号が2段の場合、下段より上段に代わる通線部品であり、どちらかが入っています。なお、品質は変わりません。

TWO TYPES AND CODES MAY BE LISTED FOR AN ITEM. THE LOWER PRODUCT MAY BE SHIPPED IN PLACE OF THE UPPER PRODUCT. QUALITY IS THE SAME.

(略図の寸法は、参考値です。 DIMENSIONS IN DRAWING FOR REFERENCE ONLY.)

FURUNO ELECTRIC CO., LTD.

FURUNO

CODE NO.	001-537-900-00	100A-X-9401-0	1/1
TYPE	CP10-09601		

工事材料表

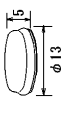
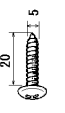
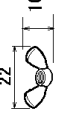
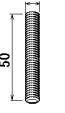
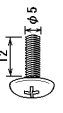
INSTALLATION MATERIALS			
番号 NO.	名称 NAME	略図 OUTLINE	数量 QTY
1	帽子 CAP		4
		型名/規格 DESCRIPTIONS 03-177-2204-0 CODE NO. 100-355-860-10	用途/備考 REMARKS
2	ナット TAPPING SCREW		4
		型名/規格 DESCRIPTIONS 5X20 SUS304 CODE NO. 000-171-997-10	
3	冷間圧造鋼ナット WING NUT		4
		型名/規格 DESCRIPTIONS M4 SUS304 CODE NO. 000-167-545-10	
4	寸切棒 THREADED ROD		4
		型名/規格 DESCRIPTIONS M4X50 SUS304 CODE NO. 000-162-679-10	
5	ナット BINDING HEAD SCREW		4
		型名/規格 DESCRIPTIONS MEX12 SUS304 CODE NO. 000-171-999-10	

(略図の寸法は、参考値です。 DIMENSIONS IN DRAWING FOR REFERENCE ONLY.)

FURUNO ELECTRIC CO., LTD.

CODE NO.	001-538-140-00	100A-X-9402-0	1/1
TYPE	CP10-09701		

工事材料表

INSTALLATION MATERIALS

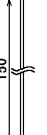
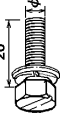
番号 NO.	名称 NAME	略図 OUTLINE	型名/規格 DESCRIPTIONS	数量 QTY	用途/備考 REMARKS
1	ケーブル CABLE TIE		CV-150N CODE NO. 000-162-166-10	8	
2	六角スリットボルト HEX HEAD SLOT BOLT-B		M6X20 SUS304 CODE NO. 000-162-348-10	4	

(略図の寸法は、参考値です。 DIMENSIONS IN DRAWING FOR REFERENCE ONLY.)



FURUNO ELECTRIC CO., LTD.

CODE NO.	001-005-660-00	100U-X-9416-7	1/1
TYPE	CP10-07011		

FSV-841A/841B, FSV-851A/851B-80

工事材料表

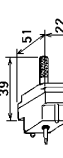
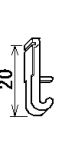
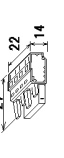
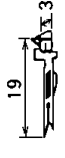
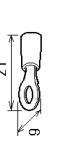
INSTALLATION MATERIALS





番号 NO.	名称 NAME	略図 OUTLINE	型名/規格 DESCRIPTIONS	数量 QTY	用途/備考 REMARKS
1	コネクタ CONNECTOR (8016)		008016-038-313761MF CODE NO. 000-159-017-11	1	
2	操作部 TERMINAL OPENER		231-131 CODE NO. 000-165-800-11	1	
3	コネクタ CONNECTOR		231-304/026-FUR CODE NO. 000-147-429-12	1	
4	コンタクト CONTACT PIN (8017)		60-8017-0313-00339F+ 60-8017-0313-00339F+ CODE NO. 000-159-417-11 000-159-417-10	2	
5	圧着端子 CRIMP-ON LUG		FV2-4 BLU K CODE NO. 000-157-247-11	3	
6	銅板 COPPER STRAP		WEA-1004-0 ROHS CODE NO. 500-310-040-10	1	

型式/コード番号が2図の場合、下図より上図に代わる通線部品であり、どちらかが入っています。なお、品質は変わりません。
TWO TYPES AND CODES MAY BE LISTED FOR AN ITEM. THE LOWER PRODUCT MAY BE SHIPPED IN PLACE OF THE UPPER PRODUCT.
QUALITY IS THE SAME.

(略図の寸法は、参考値です。 DIMENSIONS IN DRAWING FOR REFERENCE ONLY.)

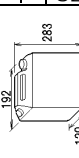
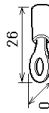
FURUNO ELECTRIC CO., LTD.

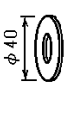
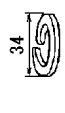
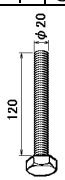
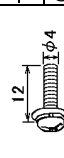

CODE NO.	001-520-120-00	10CV-X-9408 -1	1/1
TYPE	FSV-85/85L-D-T		

工事材料表		FSV-85/85L-D-T		INSTALLATION MATERIALS		略図 OUTLINE		型名/規格 DESCRIPTIONS		数量 Q'TY		用途/備考 REMARKS	
番号 NO.	名称 NAME												
1	7ヶ-不凍液 4L SOMAR ANTIFREEZE			FSV-84/84L CODE NO. 007-023-030-00		1							
2	圧着端子 CRIMP-ON LUG			FV5.5-4(LF) YEL K CODE NO. 000-166-744-11		3							
3	ハセパスト BAND			HP-5N CODE NO. 000-162-508-10		3							
4	六角ナット 1/2 HEX NUT			M20 SUS304 CODE NO. 000-167-476-10		32							
5	ミカキ丸平座金 FLAT WASHER			M20 SUS304 CODE NO. 000-167-452-10		28							
6	ハネ座金 SPRING WASHER			M20 SUS304 CODE NO. 000-167-401-10		16							
7	六角ナット 全ネジ HEXAGONAL HEAD SCREW			M20X120 SUS304 CODE NO. 000-162-825-10		12							
8	ハネ+モムAB WASHER HEAD SCREW *B*			MAX12 C2700W MBN12 CODE NO. 000-163-192-10		3							
9	0リング O-RING			CO 0117A(P355) CODE NO. 000-156-976-10		1							

(略図の寸法は、参考値です。 DIMENSIONS IN DRAWING FOR REFERENCE ONLY.)

FURUNO ELECTRIC CO., LTD.

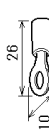
CODE NO.	001-520-130-00	10CV-X-9409 -1	1/1
TYPE	FSV-85/85L-T		

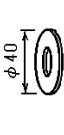
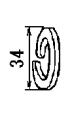
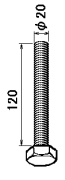
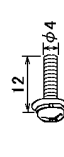
工事材料表		FSV-85/85L-T		INSTALLATION MATERIALS		略図 OUTLINE		型名/規格 DESCRIPTIONS		数量 Q'TY		用途/備考 REMARKS	
番号 NO.	名称 NAME												
1	0リング O-RING			CO 0117A(P355) CODE NO. 000-156-976-10		1							
2	圧着端子 CRIMP-ON LUG			FV5.5-4(LF) YEL K CODE NO. 000-166-744-11		3							
3	ハセパスト BAND			HP-5N CODE NO. 000-162-508-10		3							
4	六角ナット 1/2 HEX NUT			M20 SUS304 CODE NO. 000-167-476-10		32							
5	ミカキ丸平座金 FLAT WASHER			M20 SUS304 CODE NO. 000-167-452-10		28							
6	ハネ座金 SPRING WASHER			M20 SUS304 CODE NO. 000-167-401-10		16							
7	六角ナット 全ネジ HEXAGONAL HEAD SCREW			M20X120 SUS304 CODE NO. 000-162-825-10		12							
8	ハネ+モムAB WASHER HEAD SCREW *B*			MAX12 C2700W MBN12 CODE NO. 000-163-192-10		3							

(略図の寸法は、参考値です。 DIMENSIONS IN DRAWING FOR REFERENCE ONLY.)

FURUNO ELECTRIC CO., LTD.

FURUNO



CODE NO.	001-520-110-00
TYPE	FSV-85/85L

100V-X-9407-1

1/1

工事材料表

FSV-85/85L

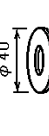
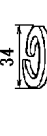
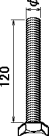
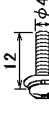
INSTALLATION MATERIALS		略図 OUTLINE		型名/規格 DESCRIPTIONS		数量 QTY		用途/備考 REMARKS	
番号 NO.	名称 NAME								
1	圧着端子 CRIMP-ON LUG			FV5.5-4(LF) YEL K CODE NO. 000-166-744-11		3			
2	ハテパント BAND			HP-5N CODE NO. 000-162-508-10		3			
3	六角ナット 1/2 HEX NUT			M20 SUS304 CODE NO. 000-167-476-10		32			
4	ミカキ丸平座金 FLAT WASHER			M20 SUS304 CODE NO. 000-167-482-10		28			
5	ハネ座金 SPRING WASHER			M20 SUS304 CODE NO. 000-167-401-10		16			
6	六角ナット 全ネジ HEXAGONAL HEAD SCREW			M20X120 SUS304 CODE NO. 000-162-825-10		12			
7	ハネ+モムAB WASHER HEAD SCREW *B*			M4X12 C2700W MBN12 CODE NO. 000-163-192-10		3			

(略図の寸法は、参考値です。 DIMENSIONS IN DRAWING FOR REFERENCE ONLY.)

FURUNO ELECTRIC CO., LTD.

C1335-M11-B

FURUNO





CODE NO.	001-520-100-00
TYPE	FSV-85/85L-D

100V-X-9406-1

1/1

工事材料表

FSV-85/85L-D

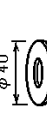
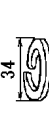
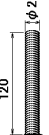
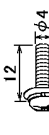
INSTALLATION MATERIALS		略図 OUTLINE		型名/規格 DESCRIPTIONS		数量 QTY		用途/備考 REMARKS	
番号 NO.	名称 NAME								
1	ソノア凍液 4L SONAR ANTIFREEZE			FSV-84/84L CODE NO. 007-023-030-30		1			
2	圧着端子 CRIMP-ON LUG			FV5.5-4(LF) YEL K CODE NO. 000-166-744-11		3			
3	ハテパント BAND			HP-5N CODE NO. 000-162-508-10		3			
4	六角ナット 1/2 HEX NUT			M20 SUS304 CODE NO. 000-167-476-10		32			
5	ミカキ丸平座金 FLAT WASHER			M20 SUS304 CODE NO. 000-167-482-10		28			
6	ハネ座金 SPRING WASHER			M20 SUS304 CODE NO. 000-167-401-10		16			
7	六角ナット 全ネジ HEXAGONAL HEAD SCREW			M20X120 SUS304 CODE NO. 000-162-825-10		12			
8	ハネ+モムAB WASHER HEAD SCREW *B*			M4X12 C2700W MBN12 CODE NO. 000-163-192-10		3			

(略図の寸法は、参考値です。 DIMENSIONS IN DRAWING FOR REFERENCE ONLY.)

FURUNO ELECTRIC CO., LTD.

C1335-M12-B

CODE NO.	001-269-290-00	100X-X-9418-1	1/1
TYPE	CP10-08101		

工事材料表

INSTALLATION MATERIALS

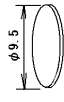
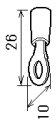
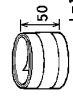
番号 NO.	名称 NAME	略図 OUTLINE	型名/規格 DESCRIPTIONS	数量 QTY	用途/備考 REMARKS
1	ブラインドシールN2.5 BLIND SEAL N2.5		09-104-6919-0 CODE NO. 100-372-550-10	1	
2	圧着端子 CRIMP-ON LUG		FV5-5-4(LF) YEL K CODE NO. 100-166-744-11	3	
3	7-ス板 COPPER STRAP		WEA-1004-0 RQHS CODE NO. 500-310-040-10	1	

(略図の寸法は、参考値です。 DIMENSIONS IN DRAWING FOR REFERENCE ONLY.)

FURUNO ELECTRIC CO., LTD.

C1344-M12-B

CODE NO.	1000-X-9408-3	1/1
TYPE		

工事材料表

FSV-24/24S

INSTALLATION MATERIALS

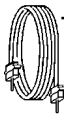
番号 NO.	名称 NAME	略図 OUTLINE	型名/規格 DESCRIPTIONS	数量 QTY	用途/備考 REMARKS
1	ケーブル (組品) CABLE ASSY.		10S2078 10S2078 CODE NO. 100-160-862-10 100-144-389-30	1	送受信装置 - 上下装置

型式/コード番号が2段の場合、下段より上段に代わる通線部品であり、どちらが入っています。なお、品質は変わりません。

TWO TYPES AND CODES MAY BE LISTED FOR AN ITEM. THE LOWER PRODUCT MAY BE SHIPPED IN PLACE OF THE UPPER PRODUCT. QUALITY IS THE SAME.

(略図の寸法は、参考値です。 DIMENSIONS IN DRAWING FOR REFERENCE ONLY.)

FURUNO ELECTRIC CO., LTD C1318-M10-C

CODE NO.	006-027-250-00	10CH-X-9405-3	1/1
TYPE	CP10-04200		

CSH-7040/CH-256





工事材料表

INSTALLATION MATERIALS		略 図 OUTLINE	型名/規格 DESCRIPTIONS	数量 Q T Y	用途/備考 REMARKS
番号 NO.	名 称 NAME				
1	TF型玉付きフック HOOK		TF-20 TF-20 CODE NO. 000-167-860-10 000-805-659-00	1	

型式/ノット番号が2段の場合、下段より上段に代わる遮断部品であり、どちらが入っています。なお、品質は変わりません。
 TWO TYPES AND CODES MAY BE LISTED FOR AN ITEM. THE LOWER PRODUCT MAY BE SHIPPED IN PLACE OF THE UPPER PRODUCT. QUALITY IS THE SAME.
 (略図の寸法は、参考値です。 DIMENSIONS IN DRAWING FOR REFERENCE ONLY.)

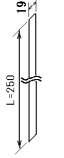
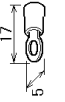
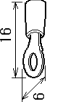
CODE NO.	001-269-660-00	10CX-X-9406-2	1/1
TYPE	CP10-08001		

工事材料表

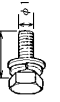
INSTALLATION MATERIALS		略 図 OUTLINE	型名/規格 DESCRIPTIONS	数量 Q T Y	用途/備考 REMARKS
番号 NO.	名 称 NAME				
1	剥電性布ナフ CONDUCTIVE TAPE		DK020PR-19 #0.25M* CODE NO. 000-177-289-10	1	
2	圧着端子 CRIMP-ON LUG		FV0.5-3 (LF) K CODE NO. 000-166-729-11	8	
3	圧着端子 CRIMP-ON LUG		FV1.25-3 (LF) RED K CODE NO. 000-166-756-11	18	
4	ミカネ平座金 FLAT WASHER		M10 SUS304 CODE NO. 000-167-232-10	2	
5	六角ナット 1/2 HEX NUT		M10 SUS304 CODE NO. 000-166-475-10	2	
6	ハネ座金 SPRING WASHER		M10 SUS304 CODE NO. 000-167-233-10	2	
7	六角ワッシャー HEX WASHER HEAD BOLT-B		M10X20 SUS304 CODE NO. 000-179-081-10	2	

(略図の寸法は、参考値です。 DIMENSIONS IN DRAWING FOR REFERENCE ONLY.)
 FURUNO ELECTRIC CO., LTD.

FURUNO

CODE NO. TYPE	001-135-210-00 CP10-07501	100V-X-9405-0 1/1			
FURUNO FSV-853		SHIP NO.			
INSTALLATION MATERIALS					
番号 NO.	名称 NAME	略図 OUTLINE	型名/規格 DESCRIPTIONS	数量 QTY	用途/備考 REMARKS
1	KB直付金具(T) KEYBOARD FIXTURE		03-103-7021-I ROMS CODE NO. 100-306-291-10	1	
2	ワッシャー頭ネジ #B* WASHER HEAD SCREW #B*		MAX12 C2700M MENS12 CODE NO. 000-163-192-10	6	
3	ゴム足 RUBBER FOOT		TM-180-302 CODE NO. 000-166-468-10	2	

型式/コード番号が異なる際の場合、下段より上段に代わる通線部品であり、どちらが入っています。なお、品質は変わりません。
 TWO TYPES AND CODES MAY BE LISTED FOR AN ITEM. THE LOWER PRODUCT MAY BE SHIPPED IN PLACE OF THE UPPER PRODUCT.
 QUALITY IS THE SAME.
 (略図の寸法は、参考値です。 DIMENSIONS IN DRAWING FOR REFERENCE ONLY.)

FURUNO ELECTRIC CO., LTD.

C1335-M05-A

FURUNO

CODE NO. TYPE	001-080-860-00 SP26-00301	26AE-X-9301-1 BOX NO. P				
FURUNO		SHIP NO.				
SPARE PARTS LIST FOR						
ITEM NO.	NAME OF PART	OUTLINE	DWG. NO. OR TYPE NO.	QUANTITY		REMARKS/CODE NO.
				WORKING PER SET	SPARE	
1	エ-キ GLASS TUBE FUSE 		FB90-A 125V 15A PBF	1	1	3 000-155-827-10
2	エ-キ GLASS TUBE FUSE 		FB90-A 125V 7A PBF	0	0	3 000-164-965-10
MFR'S NAME	FURUNO ELECTRIC CO., LTD.		DWG NO.	C4457-PO1-B		1/1
(略図の寸法は、参考値です。 DIMENSIONS IN DRAWING FOR REFERENCE ONLY.)						



表1 TABLE 1

寸法区分 (mm) DIMENSION	公差 (mm) TOLERANCE
L ≤ 50	±1.5
50 < L ≤ 100	±2.5
100 < L ≤ 500	±3

表2 TABLE 2

ケーブル長(m) CABLE LENGTH	質量(kg±10%) MASS
5	1.8
10	2.4

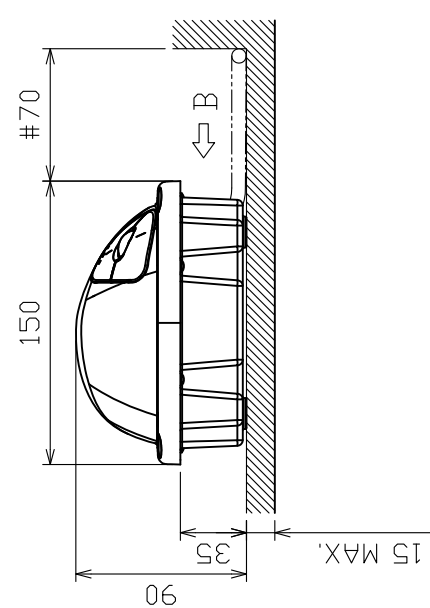
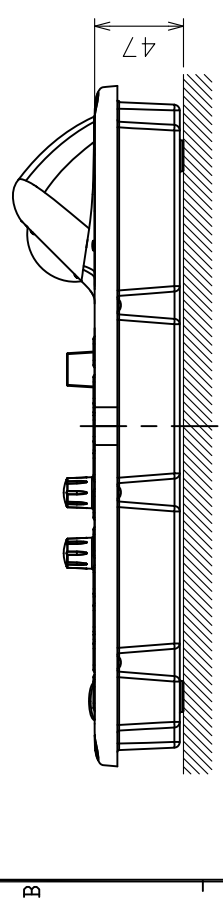
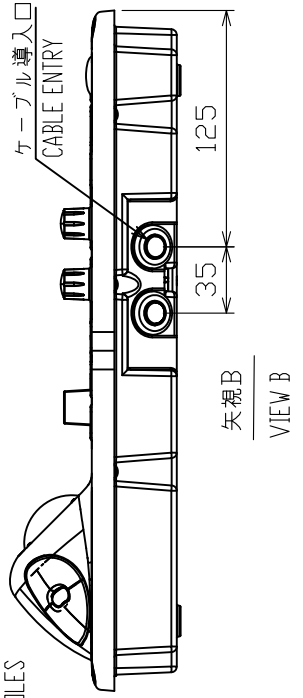
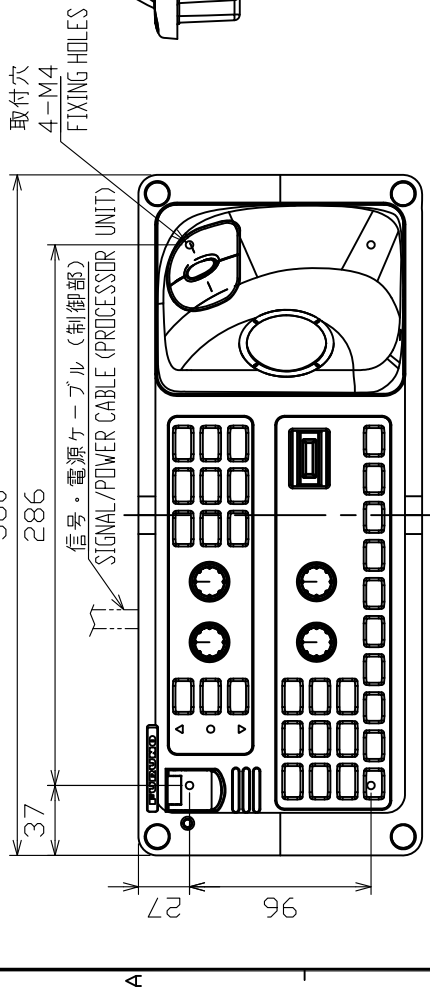
NOTE

1. TABLE 1 INDICATES TOLERANCE OF DIMENSIONS WHICH IS NOT SPECIFIED.
2. # MINIMUM SERVICE CLEARANCE.
3. USE STUD BOLTS M4X50 AND WING NUTS FOR FIXING THE UNIT.

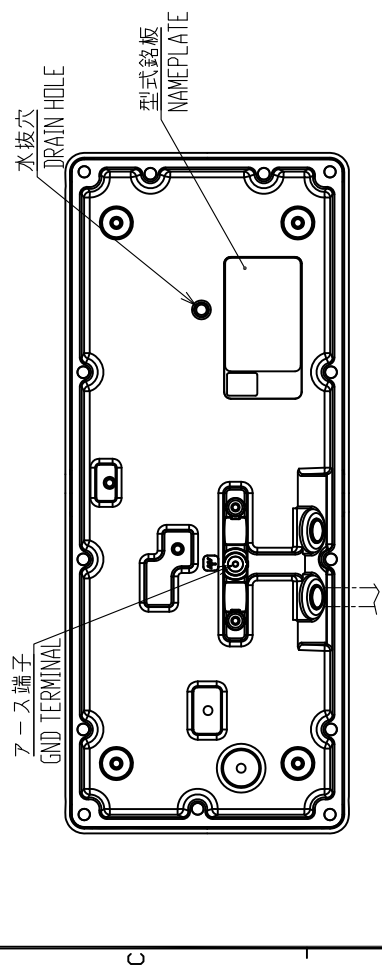

注 記

- 1) 指定外の寸法公差は表1による。
- 2) #印寸法は最小サービスイ間寸法とする。
- 3) 取付用ネジは寸切りボルトM4×50と蝶ナットを使用のこと。

DRAWN	15/Mar/2021	I.YAMASAKI	TITLE	FSV-8501-MK2
CHECKED	15/Mar/2021	H.MAKI	名称	操作部 (卓上装備)
APPROVED	7/Jul/2021	H.MAKI	外寸図	FSV-85/85L-MARK-2
SCALE	1/4	表2参照 TABLE 2	NAME	CONTROL UNIT (TABLETOP MOUNT)
DWG.No.	C1367-604-A	REF.No.	10-091-1506-0	OUTLINE DRAWING



表1 TABLE 1

寸法区分 (mm) DIMENSION	公差 (mm) TOLERANCE
L ≤ 50	±1.5
50 < L ≤ 100	±2.5
100 < L ≤ 500	±3

取付穴寸法
CUTOUT DIMENSIONS

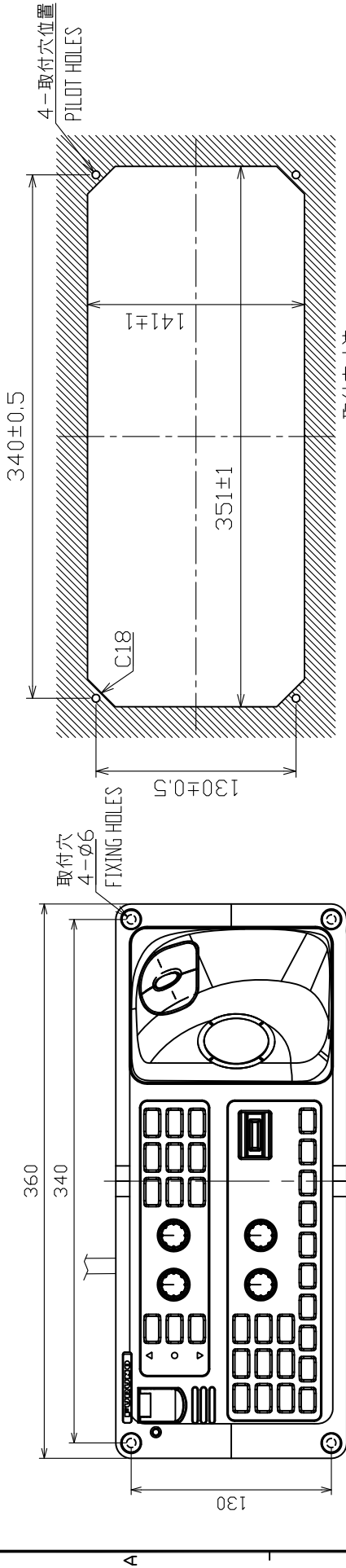

表2 TABLE 2

ケーブル長(m) CABLE LENGTH	質量 ($kg \pm 10\%$) MASS
5	1.8
10	2.4

NOTE

1. TABLE 1 INDICATES TOLERANCE OF DIMENSIONS WHICH IS NOT SPECIFIED.
2. # MINIMUM SERVICE CLEARANCE.
3. USE TAPPING SCREWS $\phi 5 \times 20$ FOR FIXING THE UNIT.

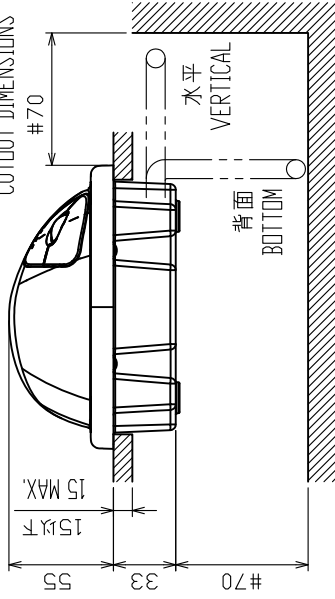
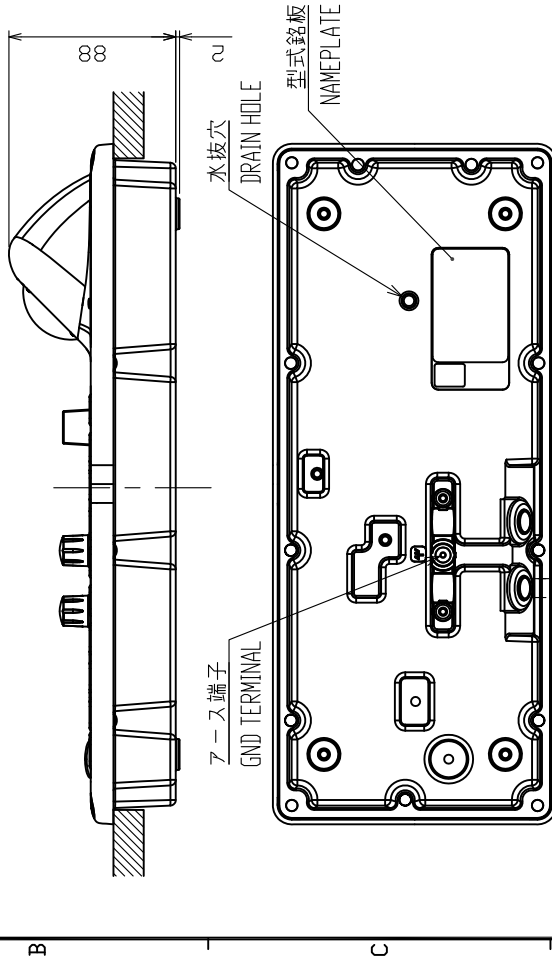

注記

- 1) 指定外の寸法公差は表1による。
- 2) #印寸法は最小サービスインスペーシングとする。
- 3) 取付用ネジはトラスタップピンネジ呼び径5×20を使用のこと。

DRAWN	16/Mar/2021	I.YAMASAKI	TITLE	FSV-8501-MK2
CHECKED	16/Mar/2021	H.MAKI	名称	操作部 (埋込装備)
APPROVED	7/Jul/2021	H.MAKI	外寸図	FSV-85/85L-MARK-2
SCALE	1/4	質量参照 TABLE 2	NAME	CONTROL UNIT (FLUSH MOUNT)
JWG.No.	C1367-605-A	REF.No.	10-091-151G-0	OUTLINE DRAWING



表1 TABLE 1

寸法区分 (mm) DIMENSION	公差 (mm) TOLERANCE
L ≤ 50	±1.5
50 < L ≤ 100	±2.5
100 < L ≤ 500	±3

表2 TABLE 2

ケーブル長(m) CABLE LENGTH	質量(kg±10%) MASS
5	2.9
10	3.5

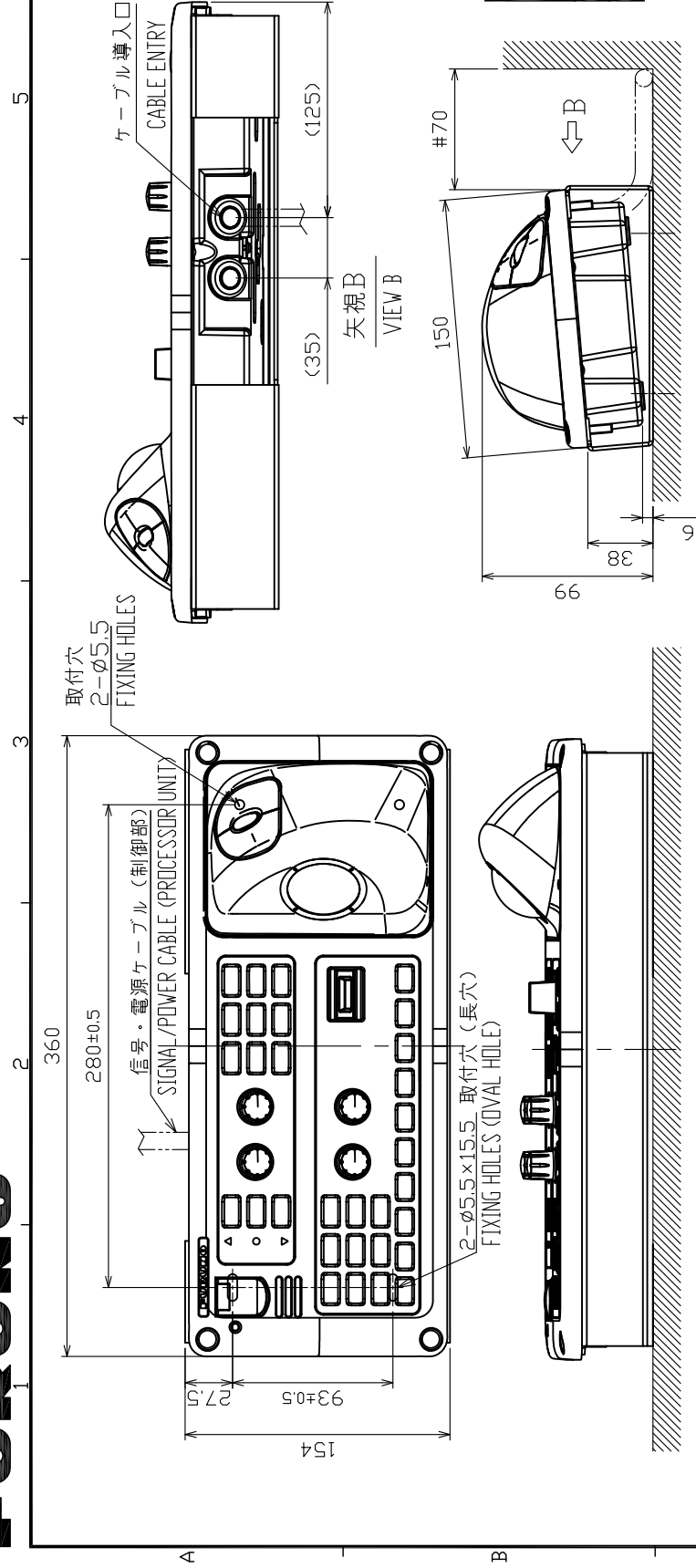
NOTE

1. TABLE 1 INDICATES TOLERANCE OF DIMENSIONS WHICH IS NOT SPECIFIED.
2. # MINIMUM SERVICE CLEARANCE.
3. USE TAPPING SCREWS Ø5x20 FOR FIXING THE UNIT.

注記

- 1) 指定外の寸法公差は表1による。
- 2) #印寸法は最小サービスインスペーシングとする。
- 3) 取付用ネジはトラスター呼び径5×20を使用のこと。

DRAWN	16/Mar/2021	I.YAMASAKI	TITLE	FSV-8501-MK2
CHECKED	16/Mar/2021	H.MAKI	名称	操作部 (取付金具)
APPROVED	7/Jul/2021	H.MAKI	外寸図	FSV-85/85L-MARK-2
SCALE	1/4	表2参照 TABLE 2	NAME	CONTROL UNIT (FIXTURE MOUNT)
JWG.No.	C1367-006-A	REF.No.	10-091-152G-0	OUTLINE DRAWING

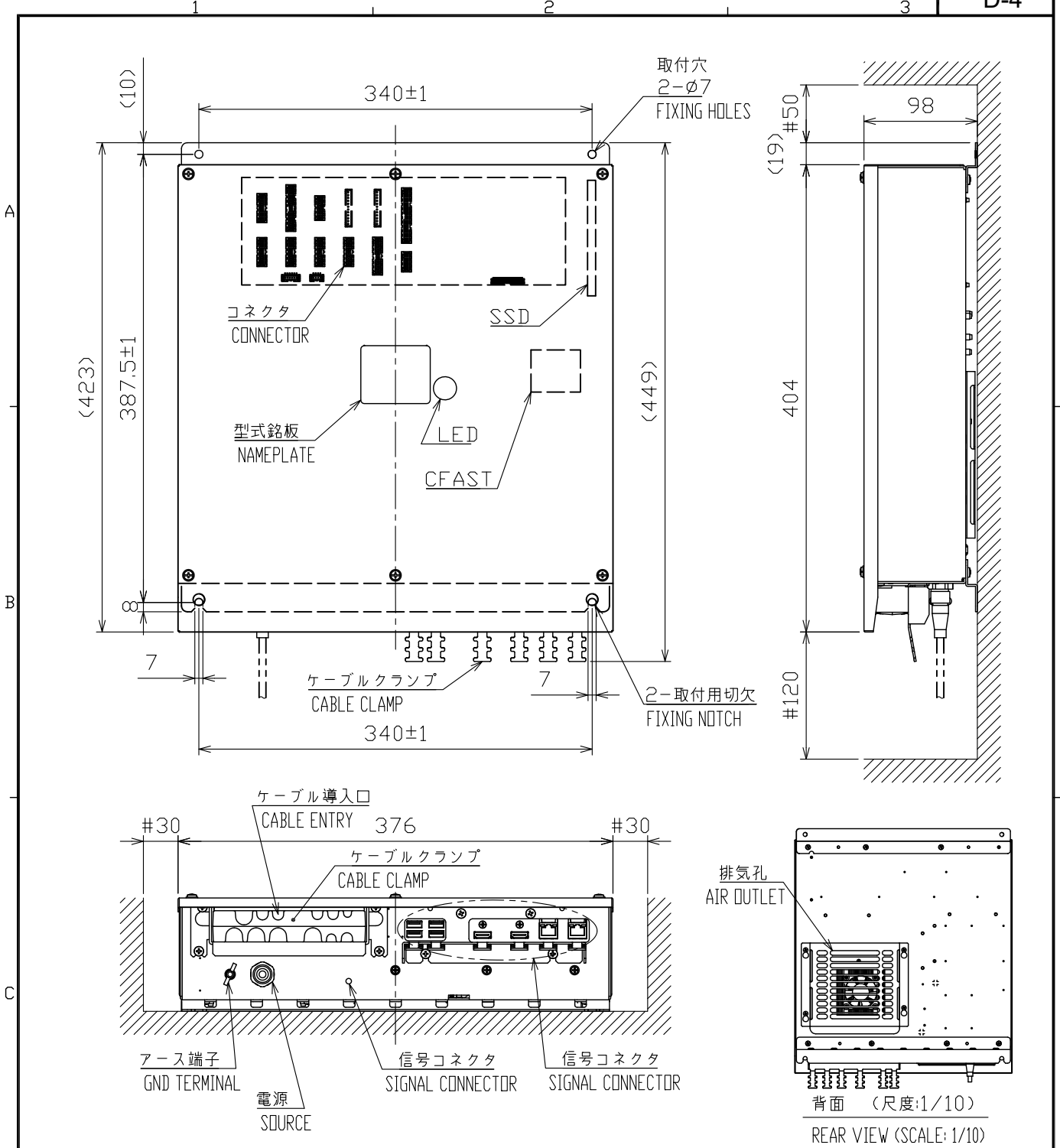

注記

- 1) 指定外の寸法公差は表 1 による。
- 2) # 印寸法は最小サービス空間寸法とする。
- 3) 取付ネジは M6 ボルトまたはコーチネジ呼び径 6 を使用のこと。

NOTE

1. TABLE 1 INDICATES TOLERANCE OF DIMENSIONS WHICH IS NOT SPECIFIED.
2. #: MINIMUM SERVICE CLEARANCE.
3. USE M6 BOLTS OR COACH SCREWS $\phi 6$ FOR FIXING THE UNIT.

表 1 TABLE 1

寸法区分 (mm) DIMENSION	公差 (mm) TOLERANCE
$L \leq 50$	± 1.5
$50 < L \leq 100$	± 2.5
$100 < L \leq 500$	± 3

DRAWN	5/Mar/2021 T.YAMASAKI	TITLE	FSV-8503-MK2
CHECKED	5/Mar/2021 H.MAKI	名称	制御部 (壁掛装備)
APPROVED	7/Jul/2021 H.MAKI	外寸図	
SCALE	1/5 MASS 7.6 $\pm 10\%$ kg	NAME	PROCESSOR UNIT (BULKHEAD MOUNT)
DWG. No.	C1367-G01-A	REF. No.	10-091-160G-0
			OUTLINE DRAWING

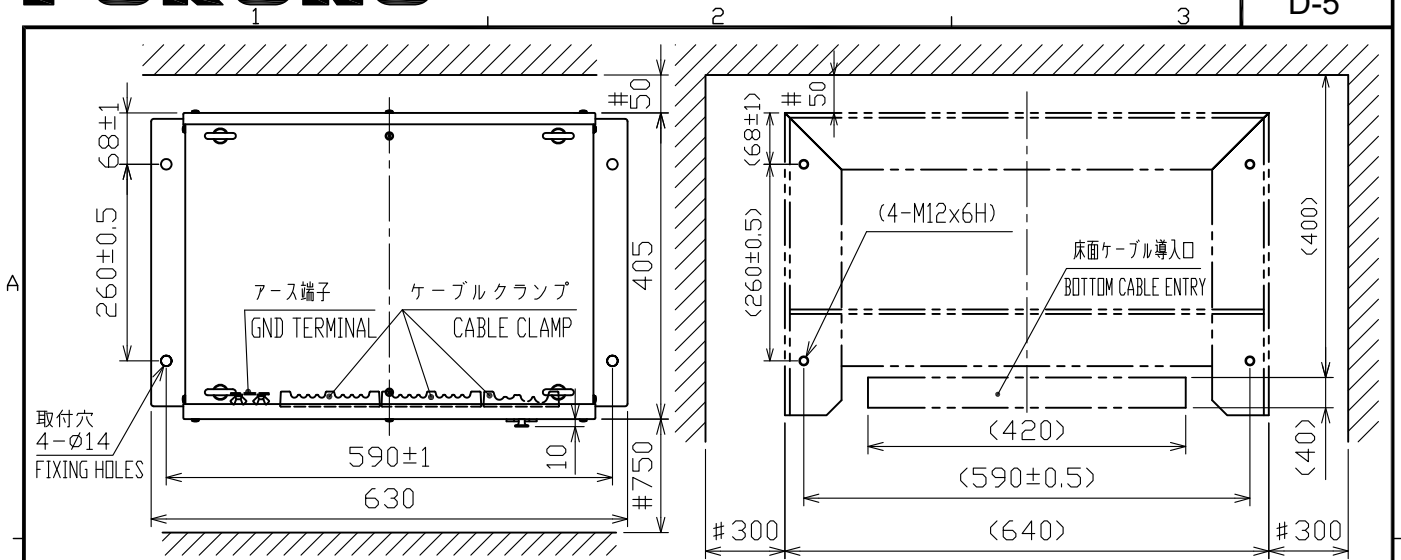

架台及び床面ケーブル導入口寸法図
DIMENSIONS OF MOUNTING BASE AND CABLE ENTRY

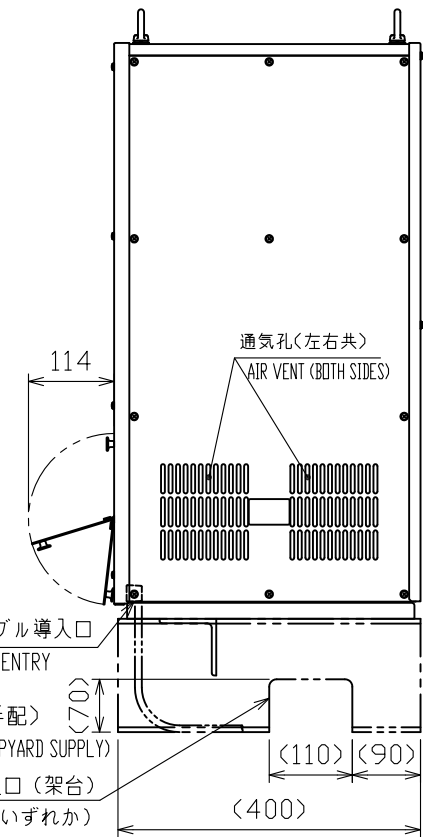
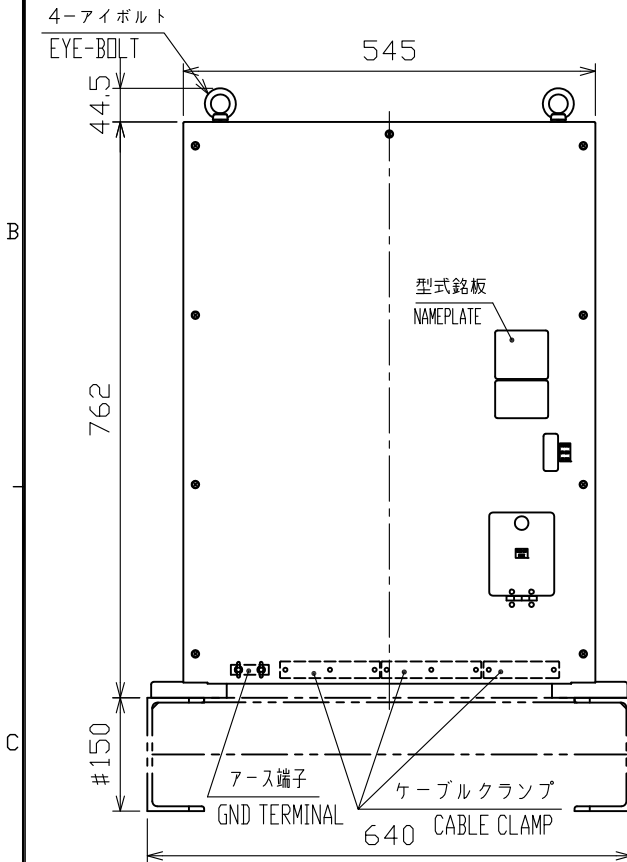

- 注記 1) 指定外の寸法公差は表1による。
 2) #印寸法は最小サービス空間寸法とする。CABLE ENTRY (LEFT OR RIGHT)
 3) 取付用ネジはM12ボルト (SUS304) を使用のこと。
 4) 架台(高さ150以上)および床面ケーブル導入口の寸法は参考寸法とする。
 直接床置の場合のみ床面ケーブル導入口を設ける。(架台材質: SS400)

- NOTE 1. TABLE 1 INDICATES TOLERANCE OF DIMENSIONS WHICH IS NOT SPECIFIED.
 2. #: MINIMUM SERVICE CLEARANCE.
 3. USE M12 BOLTS (SUS304) FOR FIXING THE UNIT.
 4. DIMENSIONS OF MOUNTING BASE (HEIGHT: 150 mm, MATERIAL: SS400) AND CABLE ENTRY ARE FOR REFERENCE ONLY. CABLE ENTRY ON DECK REQUIRED ONLY WHEN MOUNTING ON DECK DIRECTLY.

表1 TABLE 1

寸法区分 (mm) DIMENSION	公差 (mm) TOLERANCE
$L \leq 50$	± 1.5
$50 < L \leq 100$	± 2.5
$100 < L \leq 500$	± 3
$500 < L \leq 1000$	± 4

DRAWN 5/Jul/2021 T.YAMASAKI	TITLE FSV-851C/D-MK2
CHECKED 5/Jul/2021 H.MAKI	名称 送受信装置 (床置装備)
APPROVED 7/Jul/2021 H.MAKI	外寸図
SCALE 1/10 MASS 95 $\pm 10\%$ kg	NAME TRANSCEIVER UNIT (FLOOR MOUNT)
DWG. No. C1367-G02-A	REF. No. 10-091-350G-1



表2 TABLE 2

延長箱 (オプション) EXTENSION BOX (OPTION)	なし NO	あり YES
放熱ファン FAN	あり YES	なし NO
質量 (kg±10%) MASS	17.9	16.2

注記

- 1) 指定外の寸法公差は表1による。
- 2) #印寸法は最小サービス空間寸法とする。
- 3) 取付ネジはM10ボルトを使用のこと。

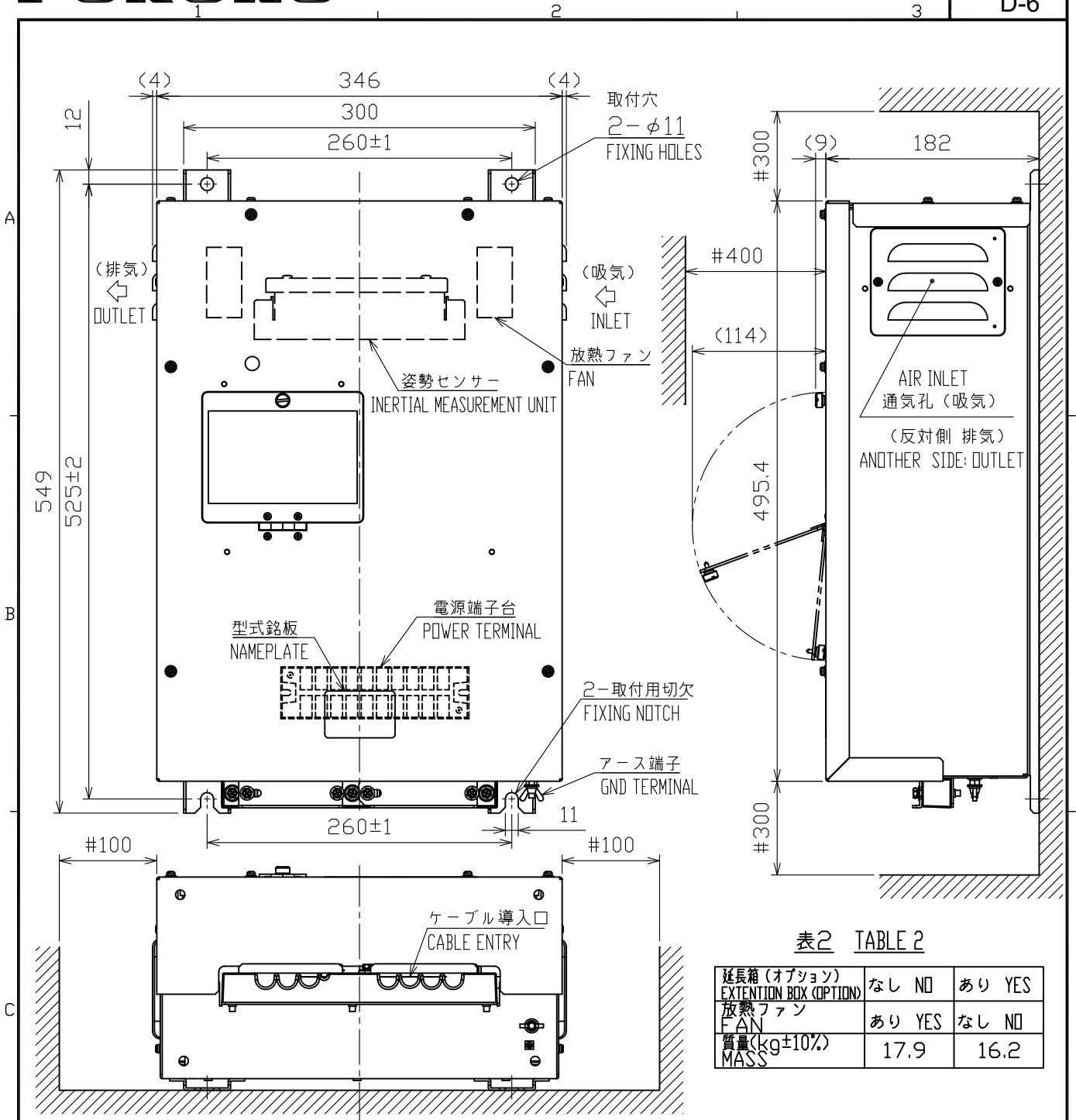
NOTE

1. TABLE 1 INDICATES TOLERANCE OF DIMENSIONS WHICH IS NOT SPECIFIED.
2. #: MINIMUM SERVICE CLEARANCE.
3. USE M10 BOLTS FOR FIXING THE UNIT.

表1 TABLE 1

寸法区分 (mm) DIMENSION	公差 (mm) TOLERANCE
L ≤ 50	±1.5
50 < L ≤ 100	±2.5
100 < L ≤ 500	±3

DRAWN 8/Mar/2021 T.YAMASAKI	TITLE FSV-8520-MK2
CHECKED 8/Mar/2021 H.MAKI	名称 上下装置制御器 (壁掛装備)
APPROVED 7/Jul/2021 H.MAKI	外寸図
SCALE 1/5 MASS表2参照 TABLE 2	NAME RAISE/LOWER CONTROL BOX (BULKHEAD MOUNT)
DWG. No. C1367-G03-A	REF. No. 10-091-280G-0

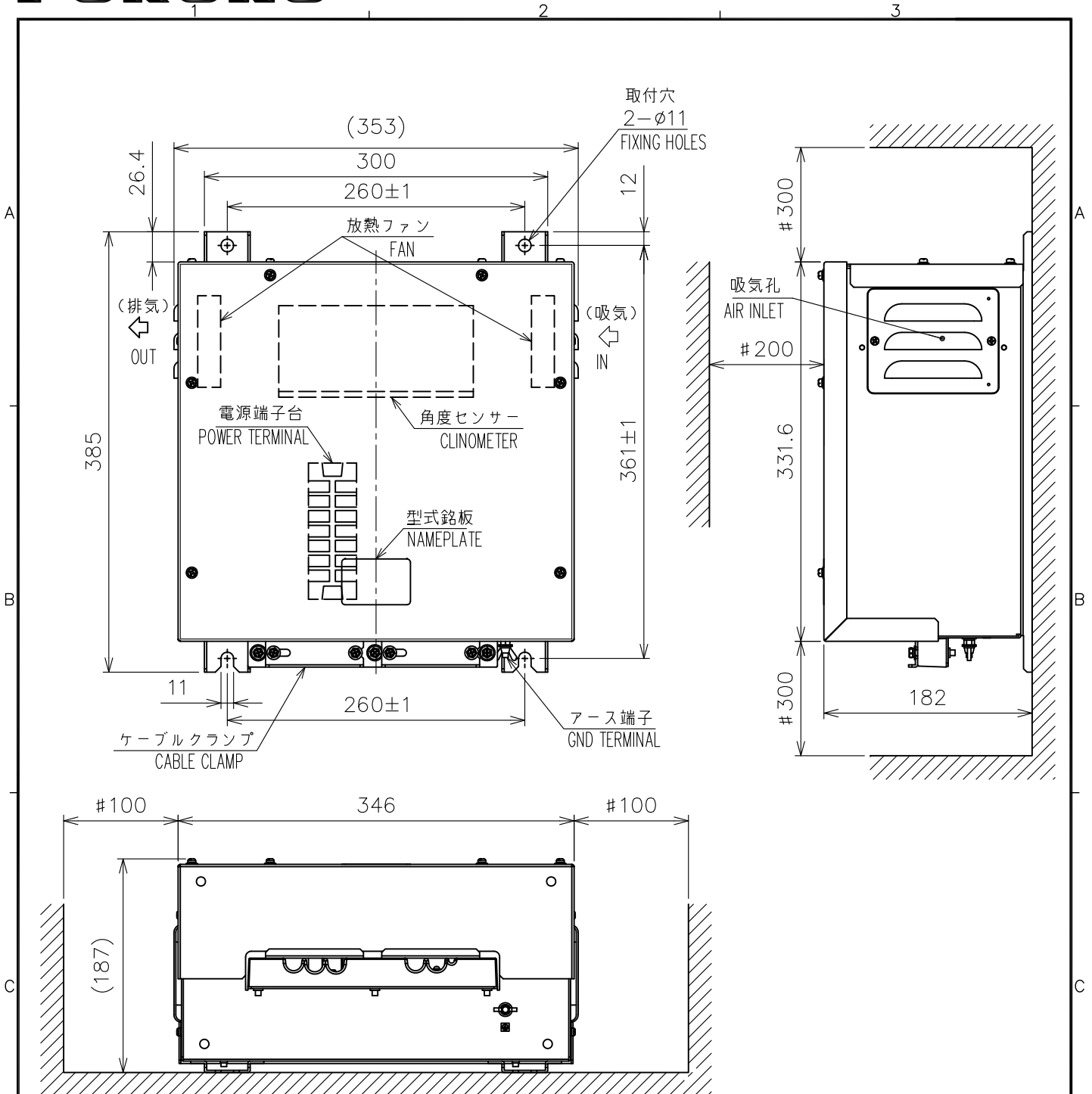

注 記

- 1) 指定外の寸法公差は表 1 による。
- 2) #印寸法は最小サービス空間寸法とする。
- 3) 取付はM10ボルトを使用のこと。

NOTE

1. TABLE 1 INDICATES TOLERANCE OF DIMENSIONS WHICH IS NOT SPECIFIED.
2. #: MINIMUM SERVICE CLEARANCE.
3. USE M10 BOLTS FOR FIXING THE UNIT.

表1 TABLE 1

寸法区分 (mm) DIMENSION	公差 (mm) TOLERANCE
L ≤ 50	±1.5
50 < L ≤ 100	±2.5
100 < L ≤ 500	±3

DRAWN 22/Apr/2014 T.YAMASAKI	TITLE FSV-2560
CHECKED 22/Apr/2014 H.MAKI	名称 制御器延長箱 (壁掛装備)
APPROVED 22/Apr/2014 H.MAKI	外寸図
SCALE 1/5	NAME CONTROL BOX EXTENSION BOX (BULKHEAD MOUNT)
MASS 9.2 ±10% kg	OUTLINE DRAWING
DWG. No. C1344-G10-B	REF. No. 10-089-590G-2

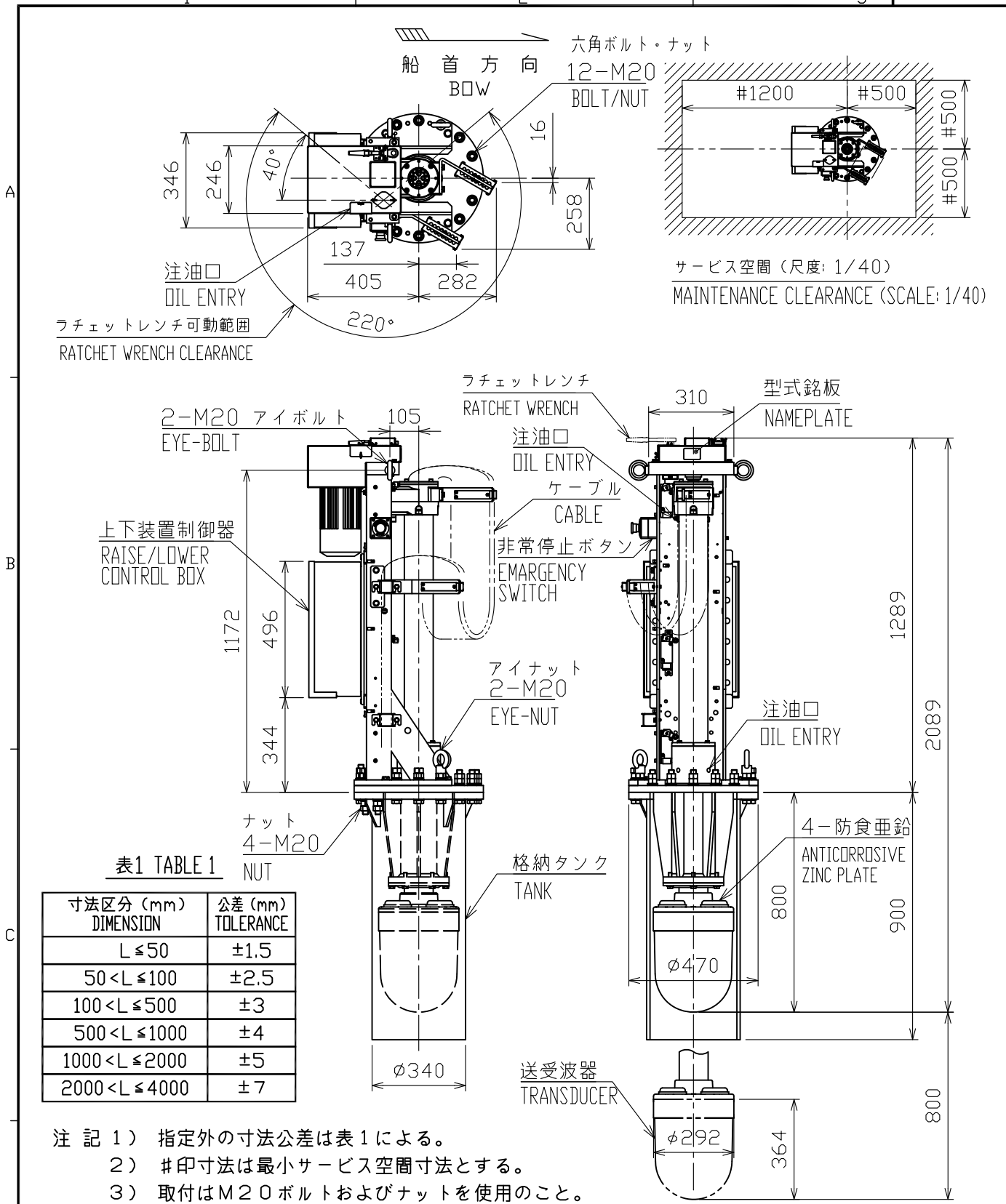

DRAWN	18/Mar/2021 J.YAMASAKI	TITLE	FSV-8471/8571 (-MK2)	
CHECKED	18/Mar/2021 H.MAKI	名称	上下装置 (ドームあり) 800ストローク	
APPROVED	24/Jun/2021 H.MAKI		外寸図	
SCALE	1/20 MASS 380 ±10% kg	質量は格納タンクを含まず。 MASS DOES NOT INCLUDE TANK.	NAME	HULL UNIT (W/ DOME) 800 TRAVEL
DWG. No.	C1336-G01-B	REF. No.	10-088-552G-2	OUTLINE DRAWING

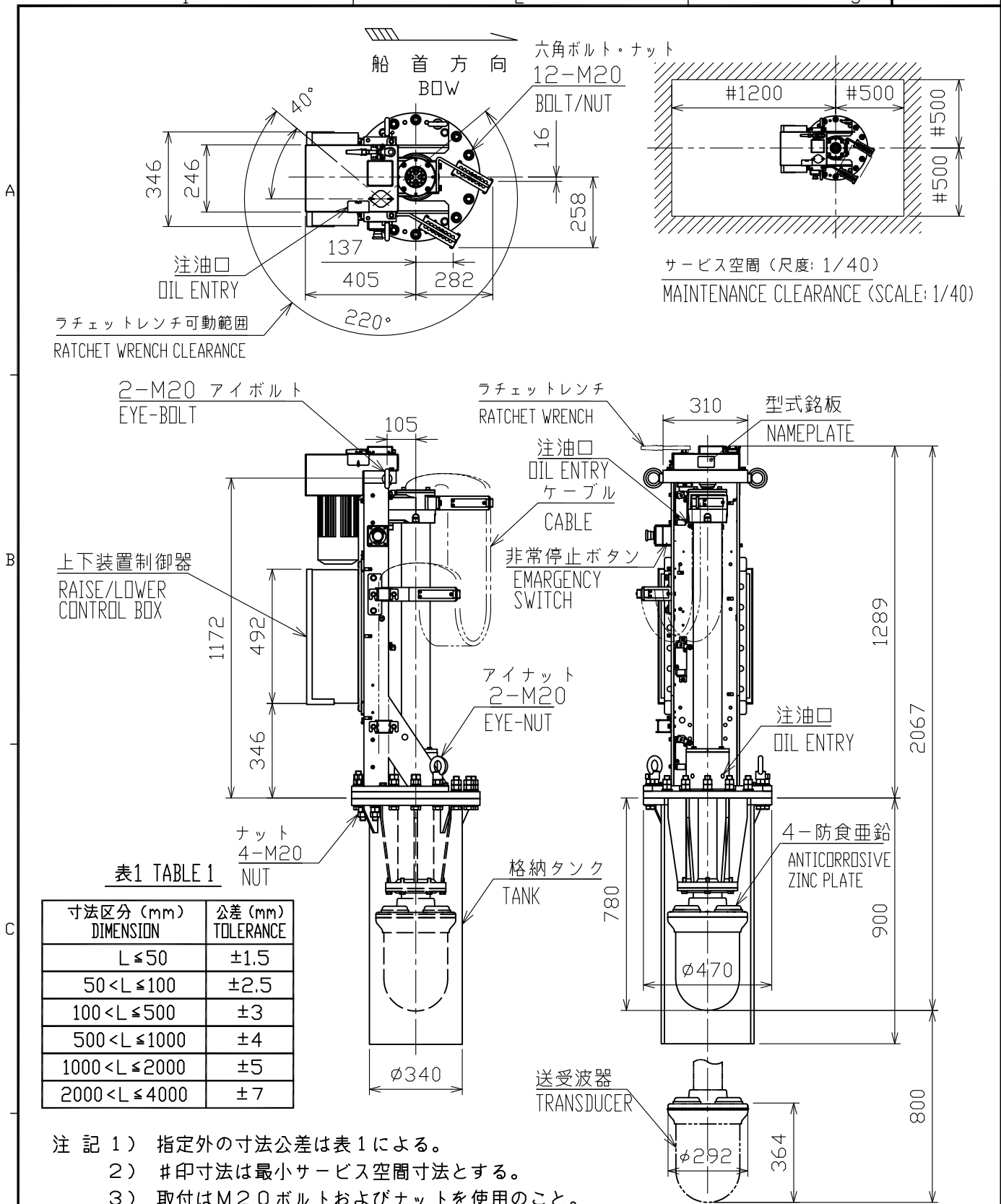

- 注記 1) 指定外の寸法公差は表1による。
 2) #印寸法は最小サービス空間寸法とする。
 3) 取付はM20ボルトおよびナットを使用のこと。

- NOTE 1. TABLE 1 INDICATES TOLERANCE OF DIMENSIONS WHICH IS NOT SPECIFIED.
 2. #: MINIMUM SERVICE CLEARANCE.
 3. USE M20 BOLTS AND NUTS FOR FIXING THE UNIT.

DRAWN	18/Mar/2021	T.YAMASAKI	TITLE	FSV-8472/8572 (-MK2)
CHECKED	18/Mar/2021	H.MAKI	名称	上下装置 (ドームなし) 800ストローク
APPROVED	24/Mar/2021	H.MAKI		外寸図
SCALE	1/20	MASS 370 ±10% kg	質量は格納タンクを含まず。 MASS DOES NOT INCLUDE TANK.	NAME
DWG. No.	C1336-G02-B	REF. No.	10-088-553G-2	OUTLINE DRAWING

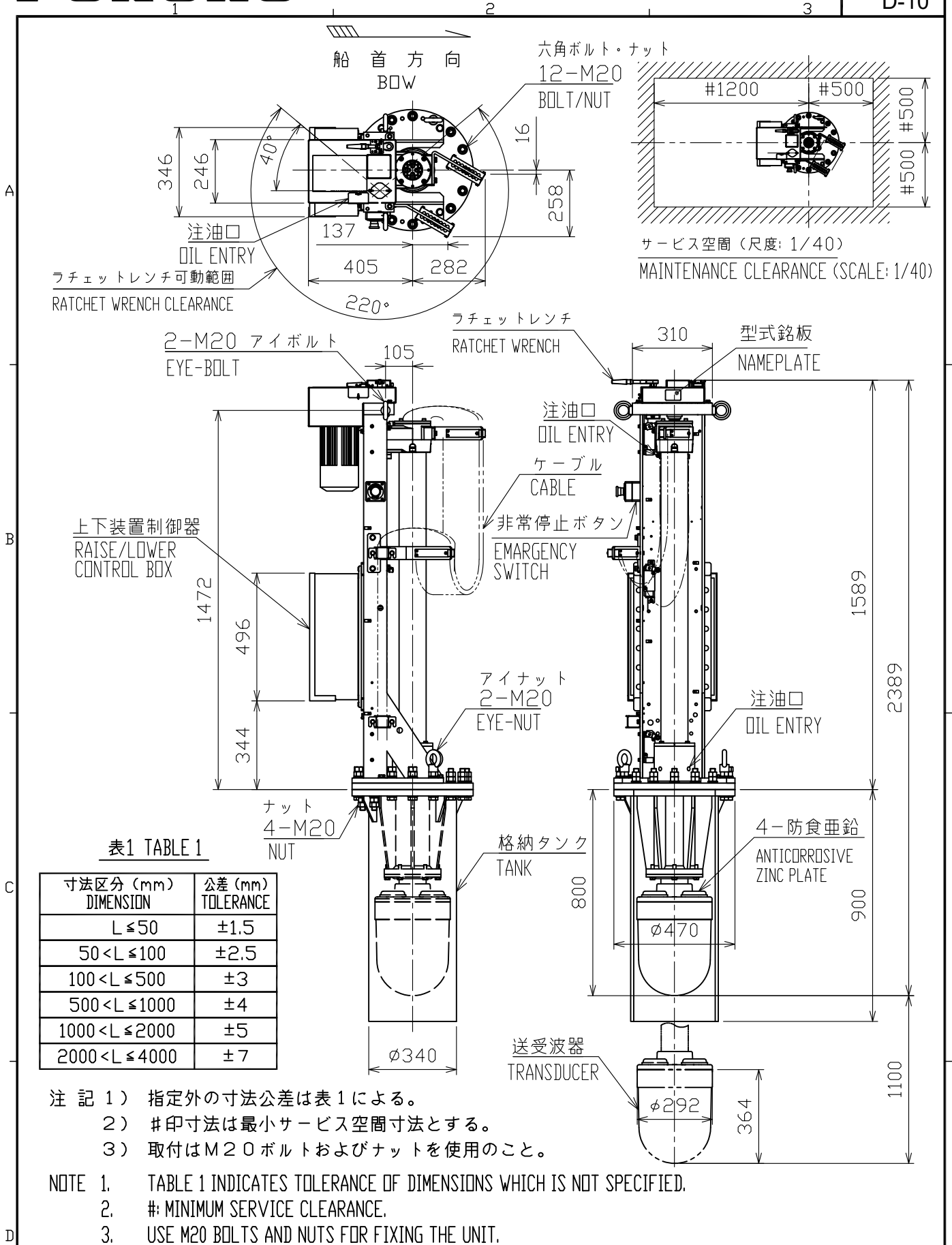

DRAWN	18/Mar/2021 T.YAMASAKI	TITLE	FSV-8481/8581 (-MK2)
CHECKED	18/Mar/2021 H.MAKI	名称	上下装置 (ドームあり) 1100ストローク
APPROVED	24/Jun/2021 H.MAKI		外寸図
SCALE	1/20	MASS	400 ±10% kg
			質量は格納タンクを含まず。 MASS DOES NOT INCLUDE TANK.
DWG. No.	C1336-G03-B	REF. No.	10-088-562G-1
			NAME
			HULL UNIT (W/ DOME) 1100 TRAVEL
			OUTLINE DRAWING

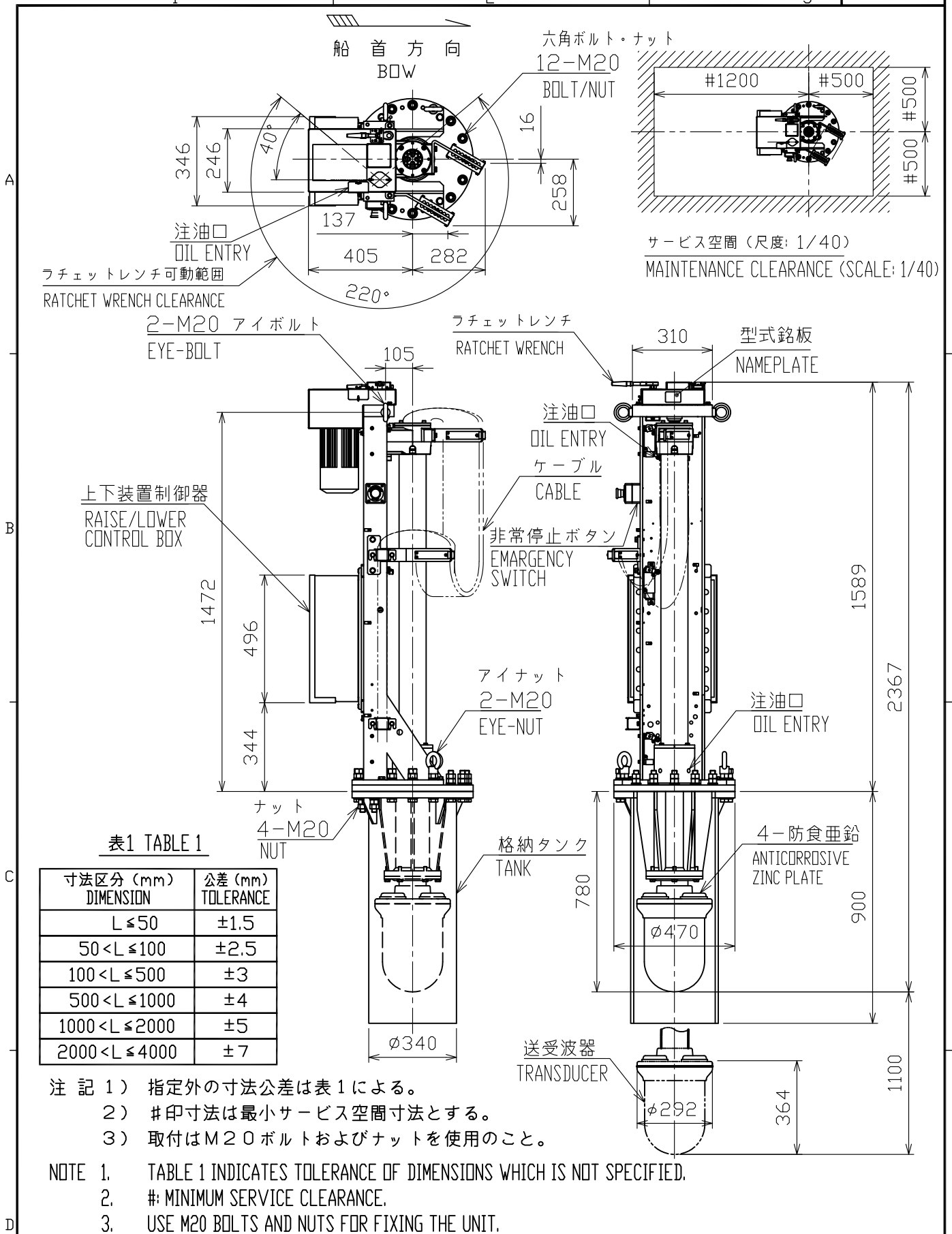

DRAWN	18/Mar/2021 T.YAMASAKI	TITLE	FSV-8482/8582 (-MK2)
CHECKED	18/Mar/2021 H.MAKI	名称	上下装置 (ドームなし) 1100ストローク
APPROVED	24/Jun/2021 H.MAKI		外寸図
SCALE	1/20	MASS	390 ±10% kg
DWG. No.	C1336-G04-B	質量は格納タンクを含まず。 MASS DOES NOT INCLUDE TANK.	NAME
		REF. No.	10-088-563G-1
			OUTLINE DRAWING

表1 TABLE 1

寸法区分 (mm) DIMENSION	公差 (mm) TOLERANCE
$L \leq 50$	± 1.5
$50 < L \leq 100$	± 2.5
$100 < L \leq 500$	± 3



表2 TABLE 2

ケーブル長 (m) CABLE LENGTH	質量 (kg $\pm 10\%$) MASS
5	0.46
10	0.76

注 記

1) 指定外の寸法公差は表 1 による。

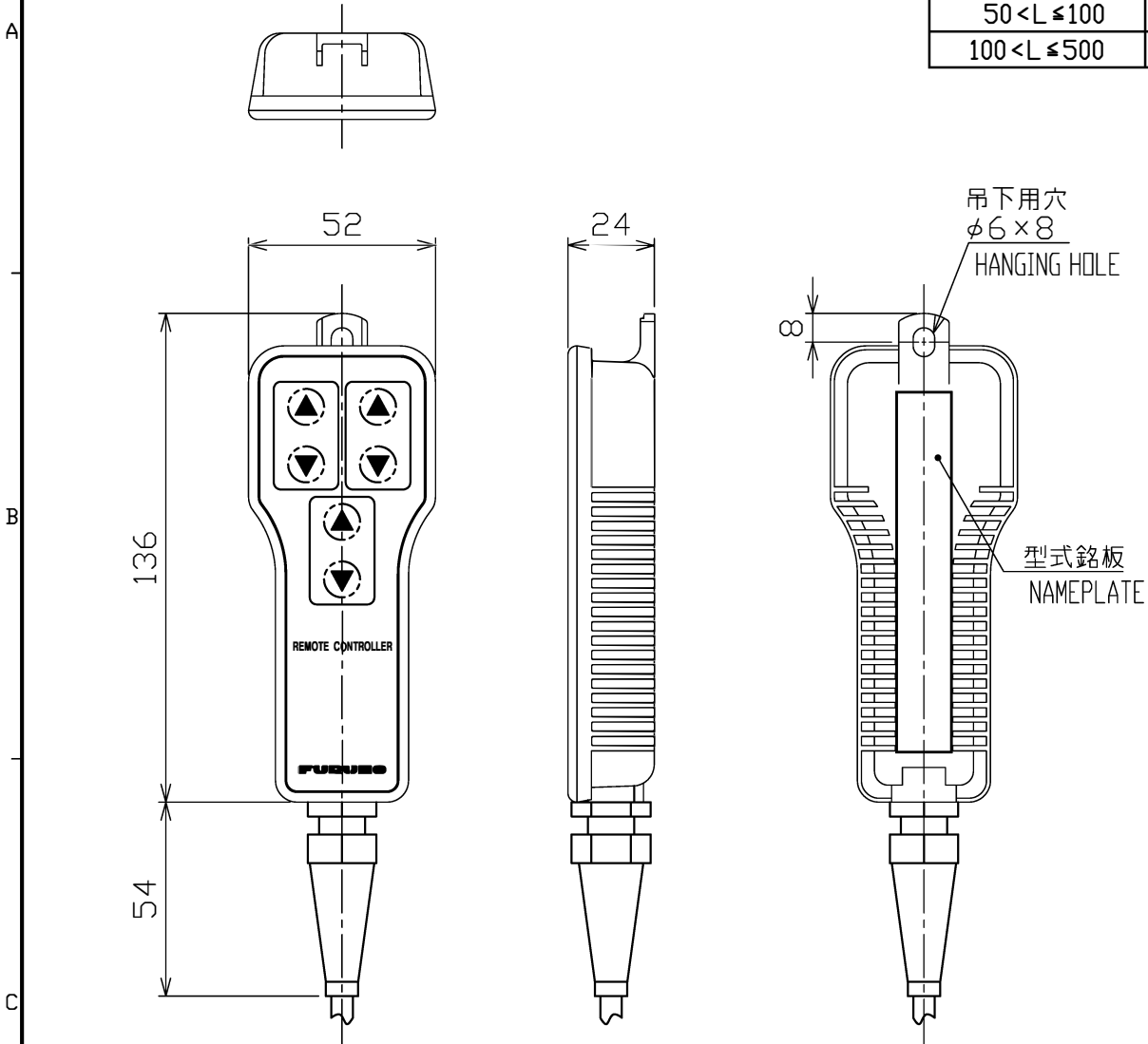
NOTE

1. TABLE 1 INDICATES TOLERANCE OF DIMENSIONS WHICH IS NOT SPECIFIED.

DRAWN 25/Jun/2021 T.YAMASAKI	TITLE FSV-854-MK2
CHECKED 25/Jun/2021 H.MAKI	名称 リモコン
APPROVED 100-101	外寸図
SCALE 1/2	NAME REMOTE CONTROLLER
DWG. No. C1367-G07-A	REF. No. 10-091-170G-1
MASS 表2参照 TABLE 2	OUTLINE DRAWING

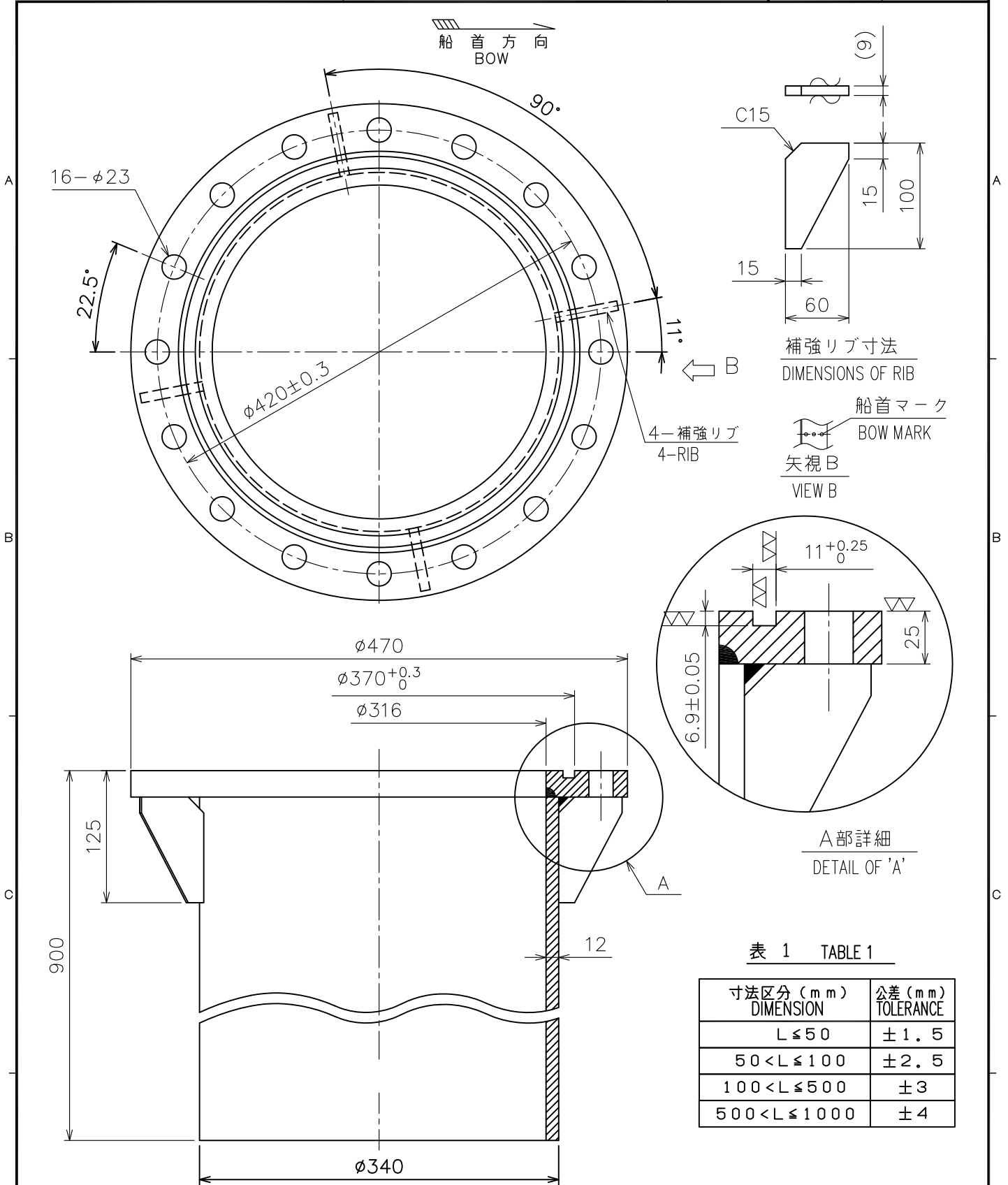

注 記 1) 指定外の寸法公差は表 1 による。

NOTE 1. TABLE 1 INDICATES TOLERANCE OF DIMENSIONS WHICH IS NOT SPECIFIED.

DRAWN	26/Jan/2021	T.YAMASAKI	TITLE	OP10-28/59	
CHECKED	26/Jan/2021	H.MAKI	名称	格納タンク (鉄)	
APPROVED	17/Feb/2021	H.MAKI	FSV-84/75	外寸図	
SCALE	1/5	MASS	100 ±10% kg	NAME	RETRACTION TANK (STEEL)
DWG. No.	C1329-G07-C		REF. No.	10-086-5801-3	OUTLINE DRAWING

A

B

C

D

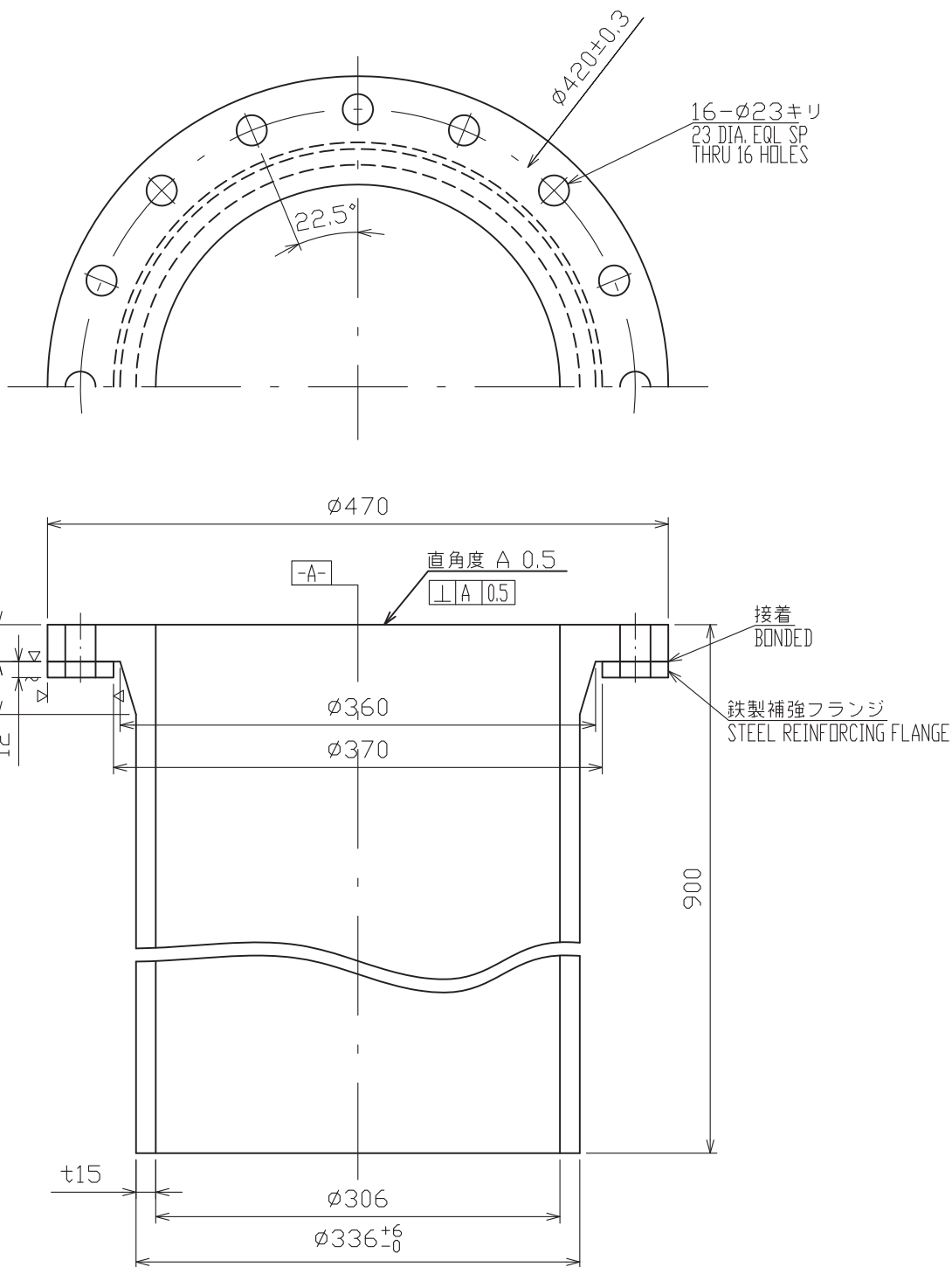

DRAWN	27/Apr/2018 T.YAMASAKI		TITLE	OP10-1
CHECKED	27/Apr/2018 H.MAKI		名称	格納タンク (FRP)
APPROVED	28/Apr/2018 H.MAKI	SH-164B, CSH-7080 SH-754B/884B		外寸図
SCALE	1/5	MASS 30 $\pm 10\%$ kg	NAME	RETRACTION TANK (FRP)
DWG. No.	C1217-086-D	REF. No.		OUTLINE DRAWING

表 1 TABLE 1

寸法区分 (mm) DIMENSION	公差 (mm) TOLERANCE
L ≤ 50	± 1.5
50 < L ≤ 100	± 2.5
100 < L ≤ 500	± 3

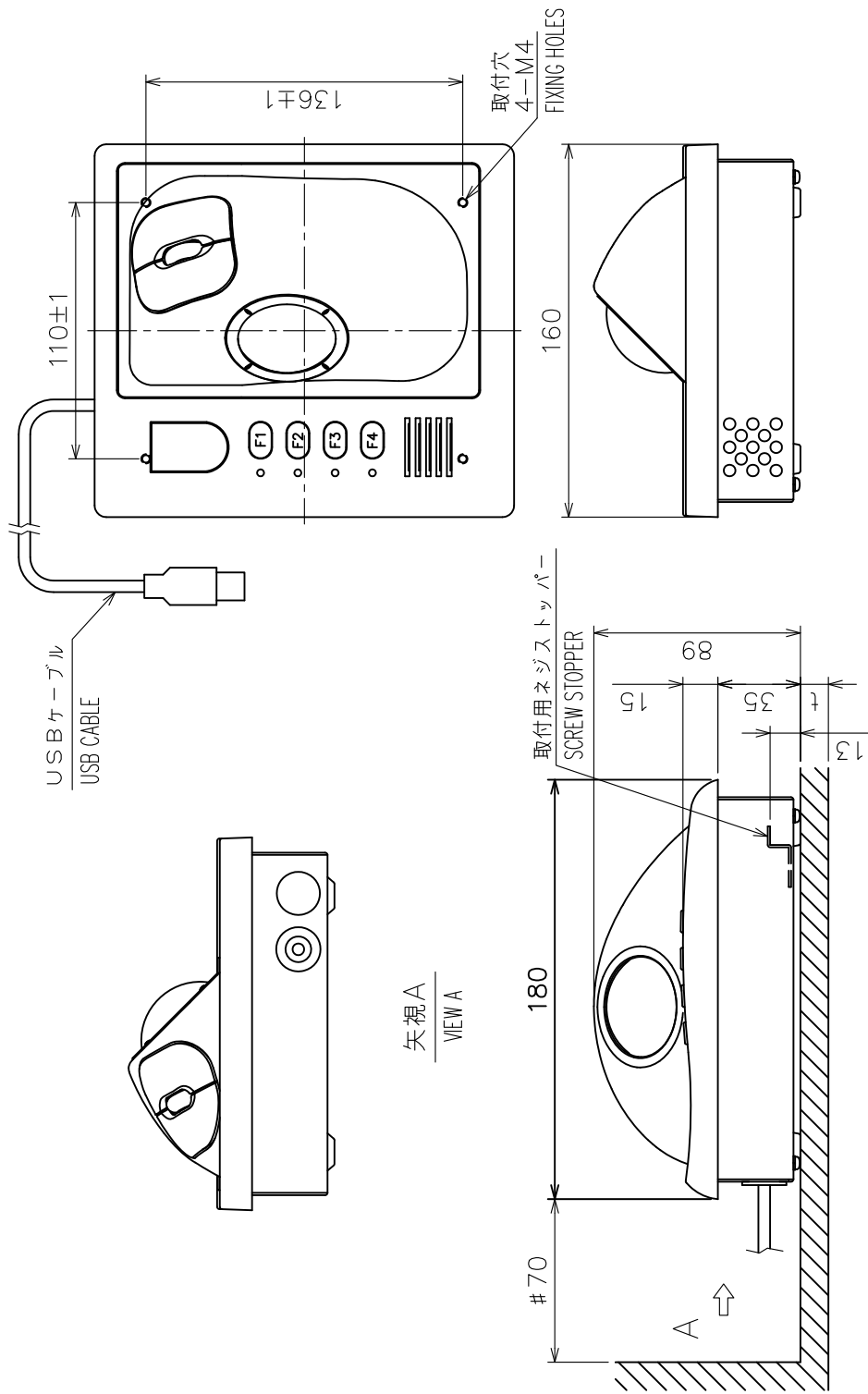

矢視 A
VIEW A

- 注 記
- 1) 指定外の寸法公差は表 1 による。
 - 2) # 印寸法は最小サービスクリアランスとする。
 - 3) 取付用ネジはセムスB (M4x12) を使用のこと。取付面板厚は最小2 最大5とする。
またはネジ長さ (+7.8, 8) ± 2 のセムスBを使用のこと。

- NOTE
1. TABLE 1 INDICATES TOLERANCE OF DIMENSIONS WHICH IS NOT SPECIFIED.
 2. #: MINIMUM SERVICE CLEARANCE.
 3. USE SEMS B SCREWS (M4x12) FOR FIXING THE UNIT. MOUNT BOARD THICKNESS (t): 2 ≤ t ≤ 5.
OR SCREW LENGTH SHOULD BE (+7.8) ± 2 FOR THICKER ONE.

DRAWN	9/Sep/2011	T. YAMASAKI	TITLE	FSV-653
CHECKED	9/Sep/2011	H. MAKI	名称	簡易操作部
APPROVED	13/Sep/2011	Y. NISHIYAMA	外寸図	
SCALE	1/3	質量 1.4 kg 質量はケーブル (5m) を含む。 MASS 1.4 kg MASS INCLUDES CABLE (5m).	NAME	SUB CONTROL UNIT
DWG. No.	C1335-G05-D	REF. No.	10-088-851G-1	OUTLINE DRAWING

表 1 TABLE 1

寸法区分 (mm) DIMENSION	公差 (mm) TOLERANCE
L ≤ 50	± 1.5
50 < L ≤ 100	± 2.5
100 < L ≤ 500	± 3

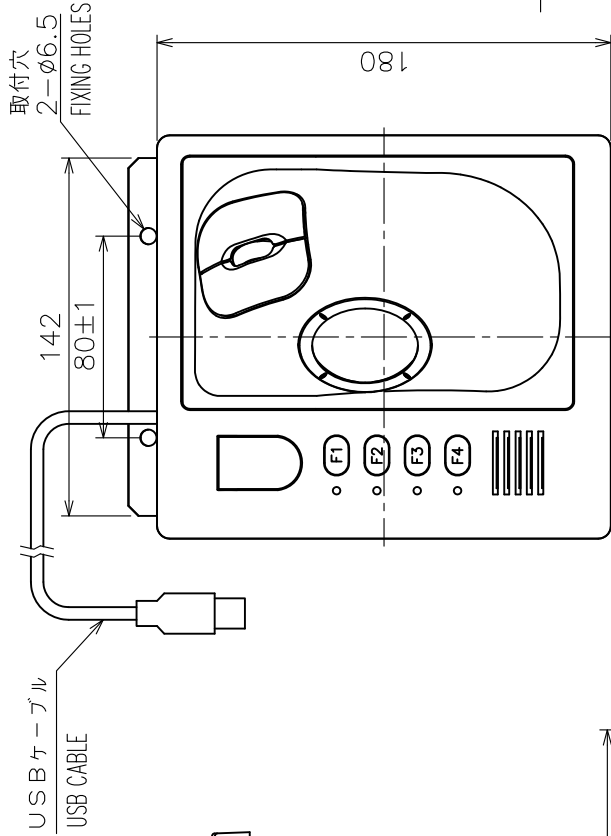

矢視 A
VIEW A

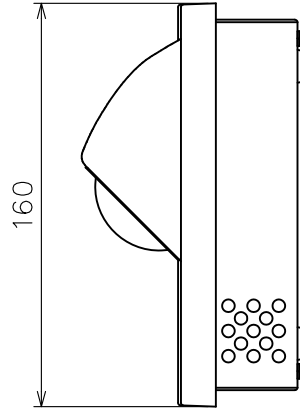

矢視 B
VIEW B

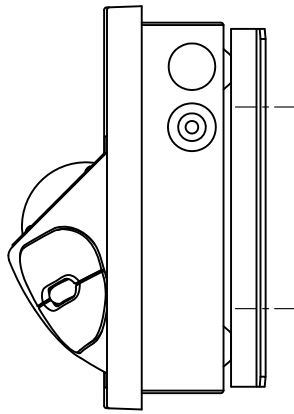

矢視 D
VIEW D

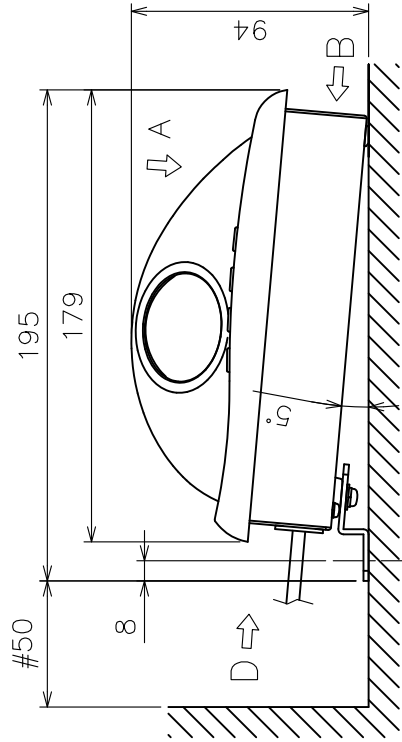

- 注 記 1) 指定外の寸法公差は表 1 による。
 2) # 印寸法は最小サービスペース寸法とする。
 3) 取付用ネジはトラスタップネジ呼び径 6、または M6 ボルトを使用のこと。
- NOTE 1. TABLE 1 INDICATES TOLERANCE OF DIMENSIONS WHICH IS NOT SPECIFIED.
 2. #: MINIMUM SERVICE CLEARANCE.
 3. USE TAPPING SCREWS φ6 OR M6 BOLTS FOR FIXING THE UNIT.

DRAWN	9/Sep/2011	I.YAMASAKI	TITLE	FSV-853
CHECKED	9/Sep/2011	H.MAKI	名称	簡易操作部 (取付金具)
APPROVED	13/Sep/2011	Y.NISHIYAMA	外寸図	
SCALE	1/3	質量 1.4 kg	NAME	SUB CONTROL UNIT (W/ FIXTURE)
DWG.No.	C1335-G07-B	質量はケーブル (5m) を含む。 MASS INCLUDES 5m CABLE.	REF.No.	10-088-853G-0
				OUTLINE DRAWING

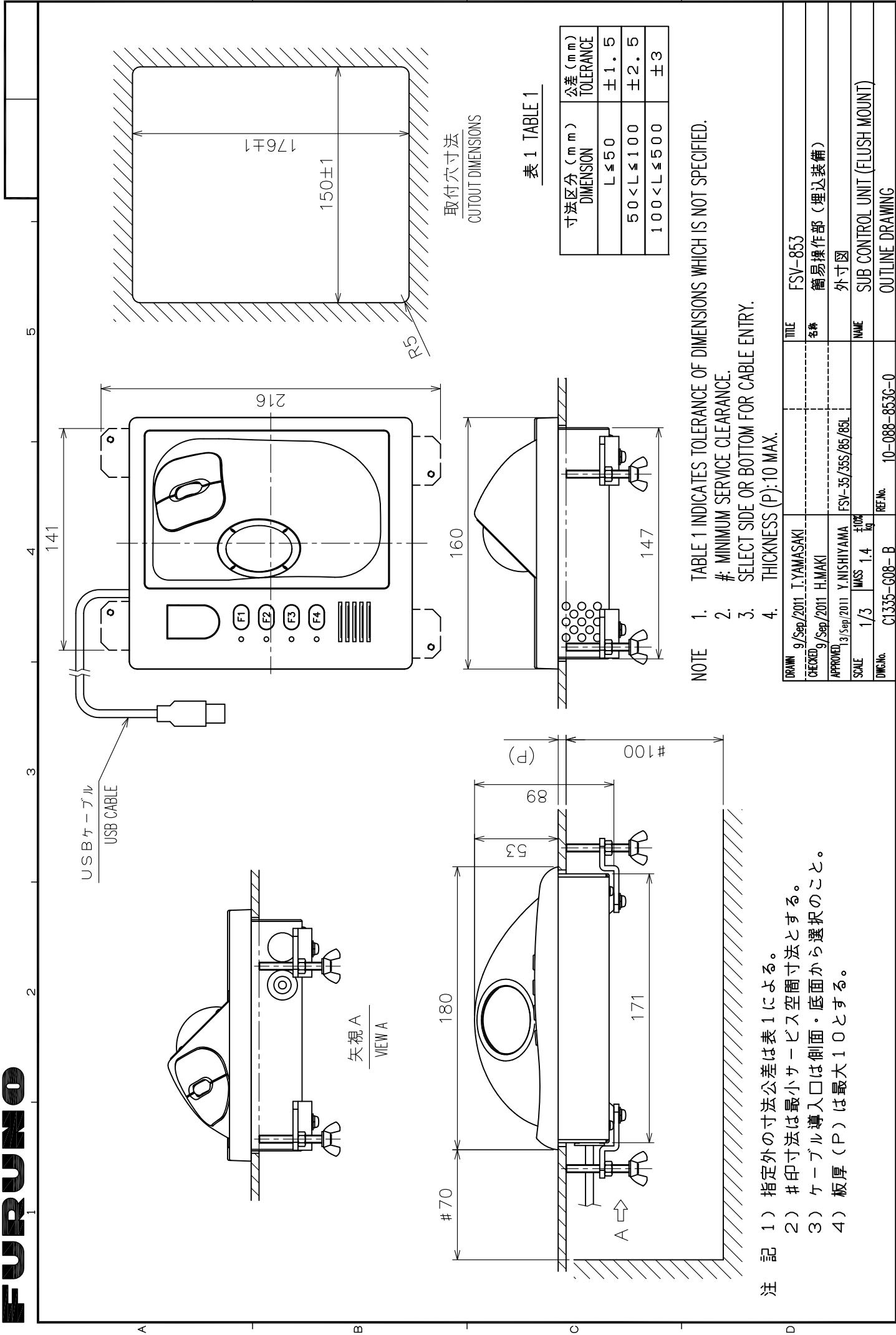

NOTE 1. TABLE 1 INDICATES TOLERANCE OF DIMENSIONS WHICH IS NOT SPECIFIED.
 2. # : MINIMUM SERVICE CLEARANCE.
 3. SELECT SIDE OR BOTTOM FOR CABLE ENTRY.
 4. THICKNESS (P): 10 MAX.

注記 1) 指定外の寸法公差は表 1 による。
 2) # 印寸法は最小サービス空間寸法とする。
 3) ケーブル導入口は側面・底面から選択のこと。
 4) 板厚 (P) は最大 10 とする。

DRAWN	g/Sep/2011	T.YAMASAKI	TITLE	FSV-853
CHECKED	g/Sep/2011	H.MAKI	名称	簡易操作部 (埋込装備)
APPROVED	13/Sep/2011	Y.NISHIYAMA	外寸図	
SCALE	1/3	MASS 1.4 kg	NAME	SUB CONTROL UNIT (FLUSH MOUNT)
DWG.No.	C1335-G08-B	REF.No.	10-088-853G-0	OUTLINE DRAWING

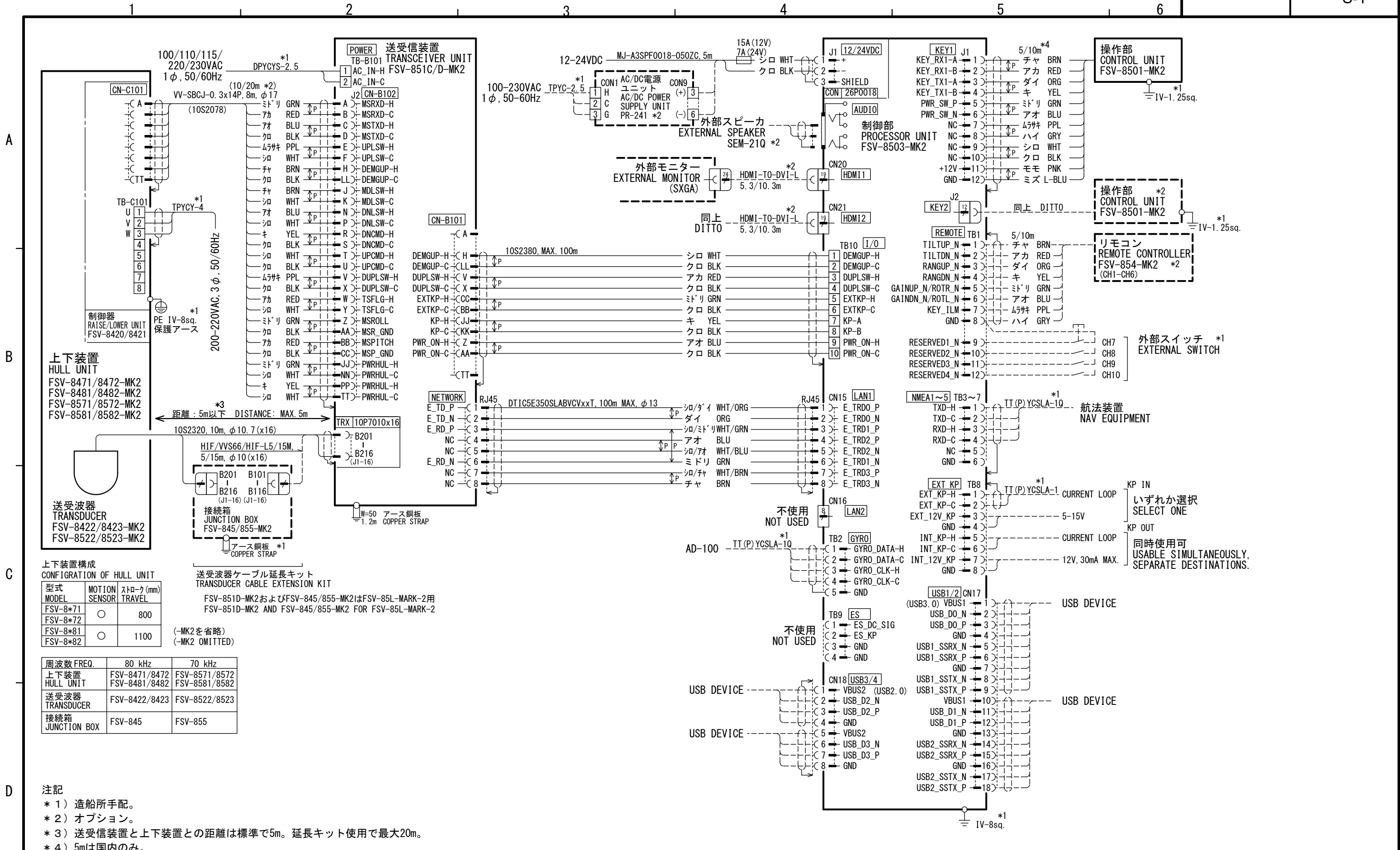

A

B

C

D

上下装置構成
CONFIGURATION OF HULL UNIT

型式 MODEL	MOTION SENSOR	ストローク(mm) TRAVEL
FSV-8*71	○	800
FSV-8*72	○	800
FSV-8*81	○	1100
FSV-8*82	○	1100

周波数 FREQ.	80 kHz	70 kHz
上下装置 HULL UNIT	FSV-8471/8472 FSV-8481/8482	FSV-8571/8572 FSV-8581/8582
送受波器 TRANSDUCER	FSV-8422/8423	FSV-8522/8523
接続箱 JUNCTION BOX	FSV-845	FSV-855

- 注記
- * 1) 造船所手配。
 - * 2) オプション。
 - * 3) 送受信装置と上下装置との距離は標準で5m。延長キット使用で最大20m。
 - * 4) 5mは国内のみ。

- NOTE
- *1: SHIPYARD SUPPLY.
 - *2: OPTION.
 - *3: DISTANCE BETWEEN TRANSCIEVER UNIT AND HULL UNIT: 5 m STANDARD. CABLE EXTENTION KIT MAY EXTEND TO 20 m MAXIMUM.
 - *4: 5m FOR JAPAN ONLY.

DRAWN 30/Jun/2021 T. YAMASAKI	TITLE FSV-85/85L-MARK-2
CHECKED 30/Jun/2021 H. MAKI	名称 カラスキャンニングソナー
APPROVED 7/Jul/2021 H. MAKI	相互結線図
SCALE MASS kg	NAME COLOR SCANNING SONAR
DWG No. G1367-C01-A	REF. No. INTERCONNECTION DIAGRAM

A

B

C

D

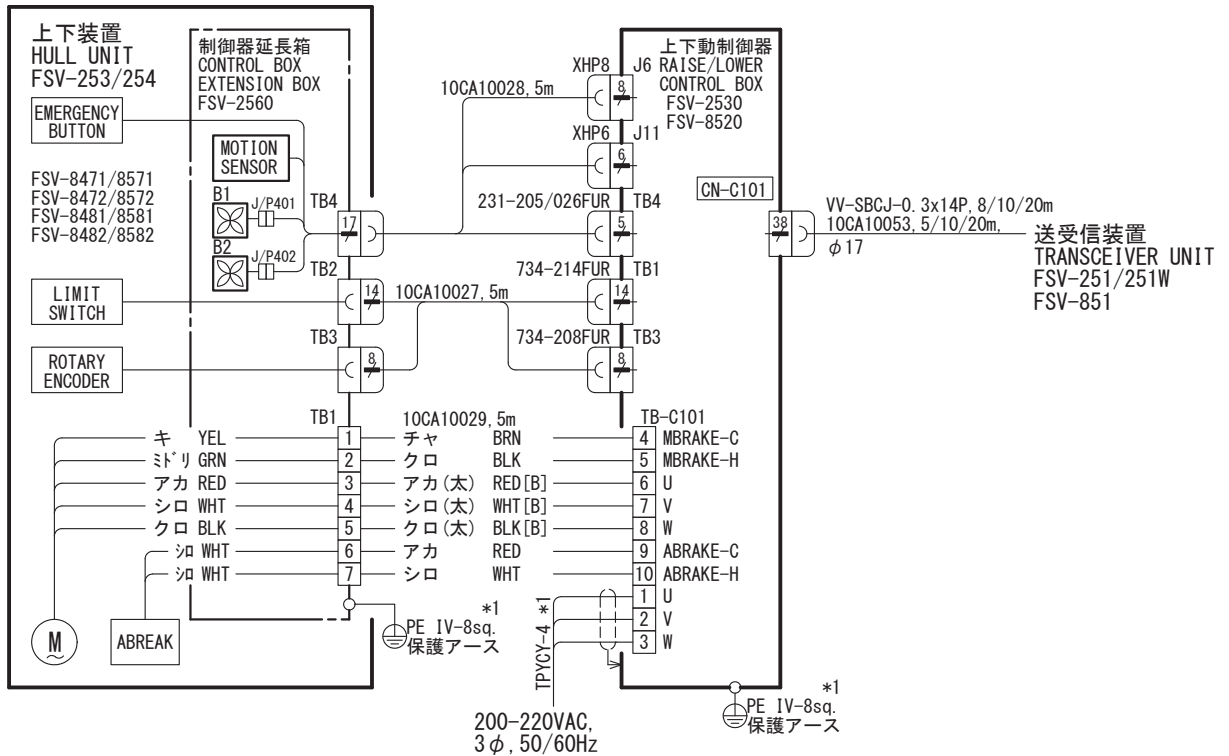

リミットスイッチ
LIMIT SWITCH

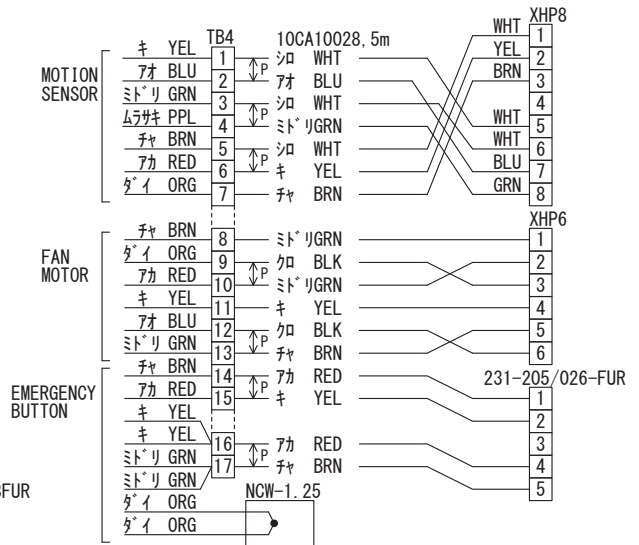
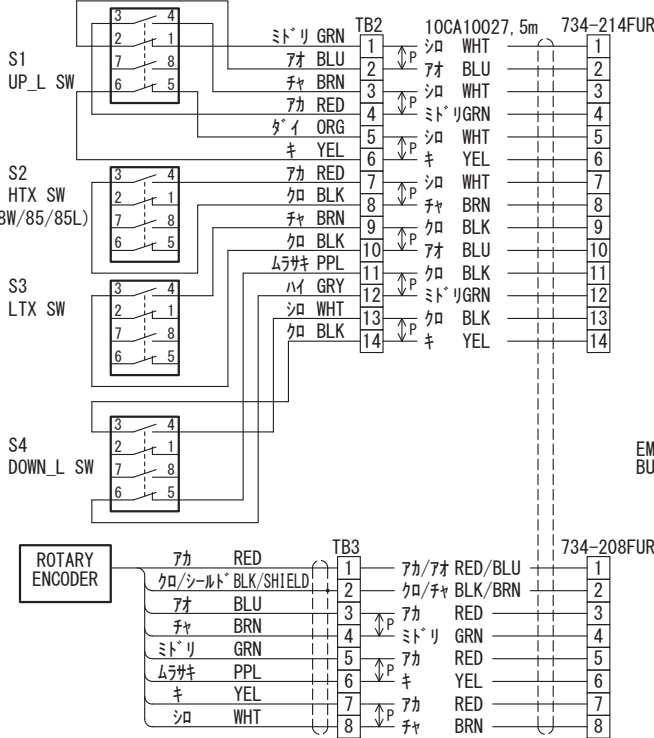

注記

* 1) 造船所手配。

NOTE

*1: SHIPYARD SUPPLY.

DRAWN 27/Feb/2019 T. YAMASAKI	TITLE FSV-2560
CHECKED 27/Feb/2019 H. MAKI	名称 制御器延長箱
APPROVED 28/Feb/2019 H. MAKI	相互結線図
SCALE MASS kg	NAME CONTROL BOX EXTENSION BOX
DWG. No. C1344-C02- G	REF. No. 10-089-5001-4
INTERCONNECTION DIAGRAM	