

# Installation Manual MULTI FUNCTION DISPLAY

## Model T<sup>Z</sup>T2BB

---

SAFETY INSTRUCTIONS .....	i
SYSTEM CONFIGURATION .....	ii
EQUIPMENT LIST .....	iii
<b>1. MOUNTING.....</b>	<b>1-1</b>
1.1 Mounting Considerations .....	1-1
1.2 How to Install the Processor Unit.....	1-2
1.3 How to Install the Switch Box.....	1-3
1.4 How to Install Transducers .....	1-4
<b>2. WIRING.....</b>	<b>2-1</b>
2.1 Interface Connections Overview .....	2-1
2.2 How to Protect the Interface Connections .....	2-2
2.3 MULTI Cable.....	2-4
2.4 DRS Radar Sensor Connections .....	2-7
2.5 Network Connections.....	2-8
2.6 USB Connections.....	2-8
2.7 VIDEO IN, HDMI IN/OUT Connections.....	2-8
2.8 CAN bus (NMEA2000 Connector).....	2-10
2.9 Example System Configurations.....	2-15
<b>3. EQUIPMENT SETUP.....</b>	<b>3-1</b>
3.1 How to Set Time Zone, Time Format and Language.....	3-3
3.2 How to Set Units of Measurement .....	3-5
3.3 Initial Setup .....	3-6
3.4 How to Set Up the Radar .....	3-12
3.5 How to Set Up the Fish Finder.....	3-15
3.6 Wireless LAN Settings .....	3-20
<b>PACKING LIST(S) .....</b>	<b>A-1</b>
<b>OUTLINE DRAWING(S).....</b>	<b>D-1</b>
<b>INTERCONNECTION DIAGRAM(S) .....</b>	<b>S-1</b>



 **FURUNO ELECTRIC CO., LTD.**

[www.furuno.com](http://www.furuno.com)

All brand and product names are trademarks, registered trademarks or service marks of their respective holders.

**ECF**

(Elemental Chlorine Free)

The paper used in this manual  
is elemental chlorine free.

**FURUNO ELECTRIC CO., LTD.**

9-52 Ashihara-cho,  
Nishinomiya, 662-8580, JAPAN

• FURUNO Authorized Distributor/Dealer

All rights reserved. Printed in Japan

Pub. No. IME-44960-F

(DAMI ) TZX2BB

A : MAY 2018

F : AUG. 04, 2022





0 0 0 1 9 4 2 2 8 1 5











# SAFETY INSTRUCTIONS

The installer must read the applicable safety instructions before attempting to install or operate the equipment.

 <b>WARNING</b>	Indicates a potentially hazardous situation which, if not avoided, could result in death or serious injury.
 <b>CAUTION</b>	Indicates a potentially hazardous situation which, if not avoided, may result in minor or moderate injury.

 Warning, Caution	 Prohibitive Action	 Mandatory Action
--	--	--

 <b>WARNING</b>	 <b>CAUTION</b>												
 <b>ELECTRICAL SHOCK HAZARD</b> <b>Do not open the equipment unless totally familiar with electrical circuits.</b>  Only qualified personnel are permitted to work inside the equipment.	 <b>Ground the equipment to prevent electrical shock and mutual interference.</b>												
 <b>Turn off the power at the switchboard before beginning the installation.</b>  Fire or electrical shock can result if the power is left on.	 <b>Use the proper fuse.</b>  Use of an incorrect fuse may damage the equipment.												
 <b>Be sure to use the designated power supply and cables.</b>  Use of incorrect power supply or cables can cause fire or damage the equipment.	 <b>Observe the following compass safe distances to prevent interference to a magnetic compass:</b> <table border="1" data-bbox="890 1332 1324 1568"> <thead> <tr> <th>Model</th> <th>Standard compass</th> <th>Steering compass</th> </tr> </thead> <tbody> <tr> <td>MPU-004</td> <td>0.50 m</td> <td>0.30 m</td> </tr> <tr> <td>PSD-003</td> <td>0.35 m</td> <td>0.30 m</td> </tr> <tr> <td>MCU-005</td> <td>0.55 m</td> <td>0.40 m</td> </tr> </tbody> </table>	Model	Standard compass	Steering compass	MPU-004	0.50 m	0.30 m	PSD-003	0.35 m	0.30 m	MCU-005	0.55 m	0.40 m
Model	Standard compass	Steering compass											
MPU-004	0.50 m	0.30 m											
PSD-003	0.35 m	0.30 m											
MCU-005	0.55 m	0.40 m											
 <b>Install a control unit (or emergency stop button) at each helm station, to allow you to disable the autopilot in an emergency.</b>  If the autopilot cannot be disabled, accidents may result.													

# SYSTEM CONFIGURATION

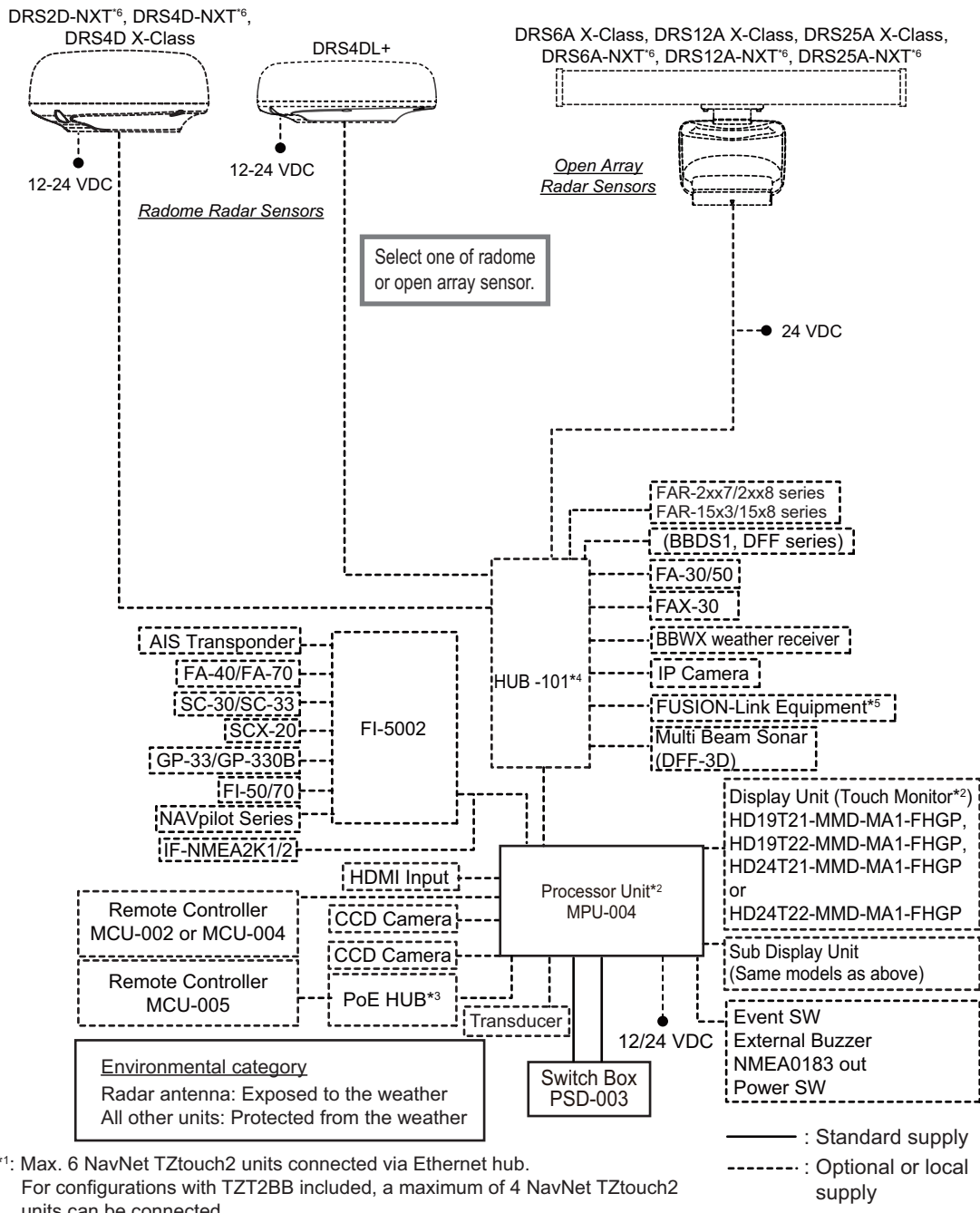

\*1: Max. 6 NavNet TZtouch2 units connected via Ethernet hub. For configurations with TZT2BB included, a maximum of 4 NavNet TZtouch2 units can be connected.  
 \*2: Hatteland Display monitor.  
 \*3: Use an after-market PoE hub. The NETGEAR GS108PE is confirmed as compatible. Compatibility tests are limited to general use as part of this configuration and in no way indicates overall capability.  
 \*4: Maximum of three can be connected.  
 \*5: FUSION-LINK units compatible with CAN bus.  
 \*6: Update the software of these radars to the following version or later before using:  
 • DRS2D-NXT, DRS4D-NXT: Ver. 01.07  
 • DRS6A-NXT, DRS12A-NXT, DRS25A-NXT: Ver. 01.02

**Note:** Do not connect/disconnect the HDMI cable between the MPU-004 and touch monitor while the power is turned on.

# EQUIPMENT LIST

## Standard supply

Name	Type	Code No.	Qty.	Remarks
Processor Unit	MPU-004	-	1	
Switch Box	PSD-003	-	1	
Installation Materials	CP19-02100	000-034-826	1	
Spare Parts	SP19-00601	001-023-040	1	Fuses

## Optional supply

Name	Type	Code No.	Remarks
Switch Box	PSD-003	000-034-828	
Joint Box	TL-CAT-012	000-167-140-10	For LAN cable extension
Remote Control Unit	MCU-002	-	
	MCU-004	-	
	MCU-005	-	
19" Maritime Multidisplay	HD19T22-MMD-MA1-FHGP	-	
24" Maritime Multidisplay	HD24T22-MMD-MA1-FHGP	-	
NMEA Data Converter	IF-NMEA2K2	000-020-510	
Ethernet Hub	HUB-101	000-011-762	
Junction Box	FI-5002	000-010-765	
Power Supply Unit	PSU-017	000-022-997	
Rectifier	RU-3423	000-030-443	For 100/110/115/220/230 V AC (Output: 24 V DC, 7 A)
	PR-62	000-013-484	For 100 V AC
		000-013-485	For 110 V AC
		000-013-486	For 220 V AC
		000-013-487	For 230 V AC
RU-1746B-2	000-030-439	For 100/110/115/220/230 V AC (Output: 24 V DC, 13 A)	
CAN bus Cable Assembly	M12-05BM+05BF-010	001-105-750-10	Length: 1 m
	M12-05BM+05BF-020	001-105-760-10	Length: 2 m
	M12-05BM+05BF-060	001-105-770-10	Length: 6 m
	M12-05BFFM-010	001-105-780-10	Length: 1 m
	M12-05BFFM-020	001-105-790-10	Length: 2 m
	M12-05BFFM-060	001-105-800-10	Length: 6 m
	CB-05PM+05BF-010	000-167-968-11	Length: 1 m
	CB-05PM+05BF-020	000-167-969-11	Length: 2 m
	CB-05PM+05BF-060	000-167-970-11	Length: 6 m
	CB-05BFFM-010	000-167-971-11	Length: 1 m
	CB-05BFFM-020	000-167-972-11	Length: 2 m
	CB-05BFFM-060	000-167-973-11	Length: 6 m
MJ Cable Assembly	MJ-A6SPF0016-005C	000-159-689-11	For FAX-30

## EQUIPMENT LIST

Name	Type	Code No.	Remarks
External Alarm Buzzer	OP03-136	000-086-443	Buzzer: PKB5-3A40
LAN Cable Assembly	MOD-Z072-020+	001-167-880-10	Length: 2 m
	MOD-Z073-030+	000-167-171-10	Length: 3 m
	MOD-Z072-050+	001-167-890-10	Length: 5 m
	MOD-Z072-100+	001-167-900-10	Length: 10 m
CAN bus connectors	SS-050505-FMF-TS001	000-168-603-10	Micro T-Connector
	NC-050505-FMF-TS001	000-160-507-10	Mini/Micro T-Connector
	LTWMC-05BMMT-SL8001	000-168-604-10	Termination Resistor (Micro)
	LTWMC-05BFFT-SL8001	000-168-605-10	
	LTWMN-05AMMT-SL8001	000-160-508-10	Termination Resistor (Mini)
	LTWMN-05AFFT-SL8001	000-160-509-10	
FRU-0505-FF-IS	001-077-830-10	In-line Terminator	
Matching Box	MB-1100	000-027-226	For 1kW transducers
Transducer	520-5PSD	000-015-204* <sup>1</sup>	
	520-5MSD	000-015-212* <sup>1</sup>	
	525-5PWD	000-027-447* <sup>1</sup>	
	520-PLD	000-023-680* <sup>1</sup>	
	525T-BSD	000-023-020* <sup>1</sup>	
	525T-PWD	000-023-019* <sup>1</sup>	
	SS60-SLTD/12	000-023-676* <sup>1</sup>	
	SS60-SLTD/20	000-023-677* <sup>1</sup>	
	525T-LTD/12	000-023-679* <sup>1</sup>	
	525T-LTD/20	000-023-678* <sup>1</sup>	
	526TID-HDD	000-023-021* <sup>1</sup>	
	50/200-1T *10M*	000-015-170* <sup>1</sup>	Require MB-1100 for connection (available separately).
	50B-6 *10M*	000-015-042	
	50B-6B *15M*	000-015-043	
200B-5S *10M*	000-015-029		
Triducer	525STID-MSD	000-011-783* <sup>1</sup>	
	525STID-PWD	000-011-784* <sup>1</sup>	
Extension Cable	C332 10M	001-464-120* <sup>2</sup>	For transducer cable extension.
Inner Hull Mounting Kit	22S0191	001-321-930	
MCU-005 Modification Kit	OP19-19	001-506-900	For retrofits.

\*1: Compatible with ACCU-FISH™, Bottom Discrimination and RezBoost™ Enhanced mode. All listed transducers are compatible with RezBoost™ Standard mode.

\*2: Use of the extension cable may cause the following problems:

- Reduced detection ability
- Wrong ACCU-FISH™ information (fish length smaller than actual length, fewer fish detections, error in individual fish detection).
- Wrong speed data
- No TD-ID recognition

# 1. MOUNTING

---

## 1.1 Mounting Considerations

When selecting a mounting location, keep the following points in mind:

- Install the units indoors.
- Locate the units away from water splash.
- The operating temperature range of the processor unit is -15°C to 55°C (-27°F to 99°F). Be sure the mounting location satisfies this requirement.
- Locate the units away from exhaust pipes and vents.
- The mounting locations should be well ventilated.
- Mount the units where shock and vibration are minimal.
- Keep the units away from electromagnetic field-generating equipment such as motors and generators.
- Referring to the outline drawings at the back of this manual, leave sufficient room for service and maintenance. Also, leave slack in cables for maintenance and servicing ease.
- A magnetic compass may receive interference if it is placed too close to these units. Observe the compass safe distances noted in the safety instructions to prevent interference to the magnetic compass.
- The processor unit is equipped with an internal LAN antenna and should be installed in a location where the signal is not interrupted or halted by obstructions. **If you cannot install the processor in an obstruction-free location**, connect the processor unit to a wireless LAN router via LAN cable to establish an ETHERNET connection.

## 1.2 How to Install the Processor Unit

The Processor Unit (MPU-004) can be installed on a flat surface (such as a desktop) or on a bulkhead.

### 1.2.1 Bulkhead installation

1. Referring to the outline drawing at the back of this manual, drill four holes for the mounting screws (self-tapping  $\phi 5 \times 20$ , supplied as installation materials).
2. Fit two screws to the upper holes, leaving sufficient thread exposed to hang the processor unit.
3. Hang the processor unit on the two fitted screws, taking care that the processor is correctly oriented, with the cables and connectors facing downwards.

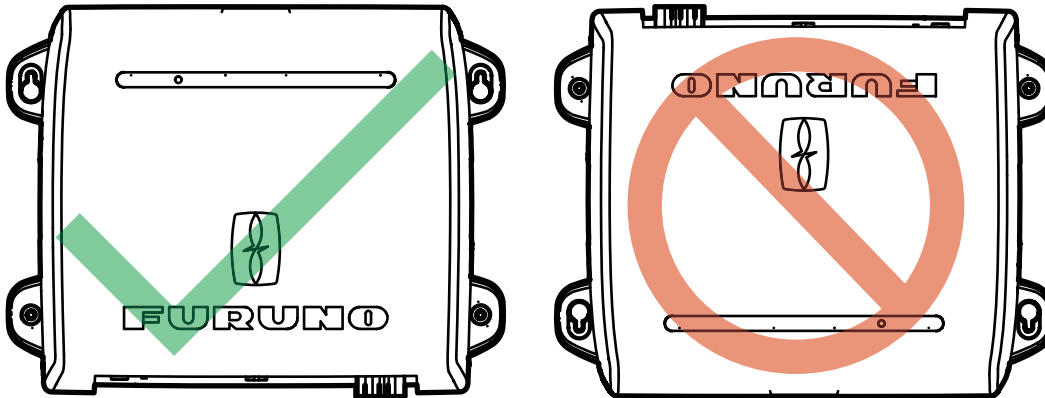

4. Loosely fasten two screws to the bottom two holes.
5. Fasten all four screws evenly, securing the processor unit to the installation location.

### 1.2.2 Flat Surface (desktop) installation

1. Referring to the outline drawing at the back of this manual, drill four holes for the mounting screws (self-tapping  $\phi 5 \times 20$ , supplied as installation materials).
2. Fit two screws to the upper holes, leaving sufficient thread exposed to fit the processor unit.
3. Slide the processor unit on the two fitted screws.
4. Loosely fasten two screws to the bottom two holes.
5. Fasten all four screws evenly, securing the processor unit to the installation location.



## 1.3 How to Install the Switch Box

The switch box (PSD-003) is designed to be flush mounted on a flat surface, such as a bulkhead or console.

1. Referring to the supplied outline drawing, make a cutout at the mounting location.
2. Unfasten the two screws that connect the flushmount bracket to the PSD-003, then remove the bracket. The bracket and screws are reused.
3. Fit the flushmount sponge (included as installation materials) to the rear of the switch box.
4. Insert the switch box to the cutout.  
**Note:** Take care that the cables are not pinched or squashed.
5. Fit the flushmount bracket (removed at step 2) to the rear of the unit, then secure the bracket with two screws.
6. Tighten the wing bolts to fasten the switch box.
7. Tighten the wing nuts to fasten the flushmount bracket, securing the switch box.

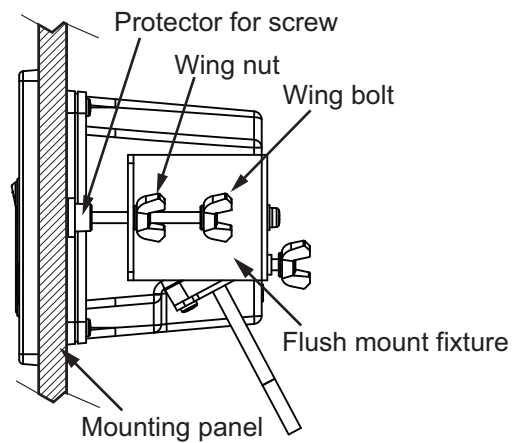

## 1.4 How to Install Transducers

**Note:** For configurations using the DFF-3D, see the DFF-3D installation instructions in the operator's manual (OME-13520-xx; xx indicates publication version).

### 1.4.1 How to install a transducer through the hull

#### Transducer mounting location

The thru-hull mount transducer provides the best performance of all, since the transducer protrudes from the hull and the effect of air bubbles and turbulence near the hull skin is reduced. If your boat has a keel, the transducer should be at least 30 cm away from it.

The performance of this fish finder is directly related to the mounting location of the transducer, especially for high-speed cruising. The installation should be planned in advance, keeping the length of the transducer cable and the following factors in mind:

- Air bubbles and turbulence caused by movement of the boat seriously degrade the sounding capability of the transducer. The transducer should, therefore, be located in a position where water flow is the smoothest. Noise from the propellers also adversely affects performance and the transducer should not be mounted nearby. The lifting strakes are notorious for creating acoustic noise, and these must be avoided by keeping the transducer inboard of them.
- The transducer must always remain submerged, even when the boat is rolling, pitching or up on a plane at high speed.
- A practical choice would be somewhere between 1/3 and 1/2 of your boat's length from the stern. For planing hulls, a practical location is generally rather far astern, so that the transducer is always in water regardless of the planing attitude.

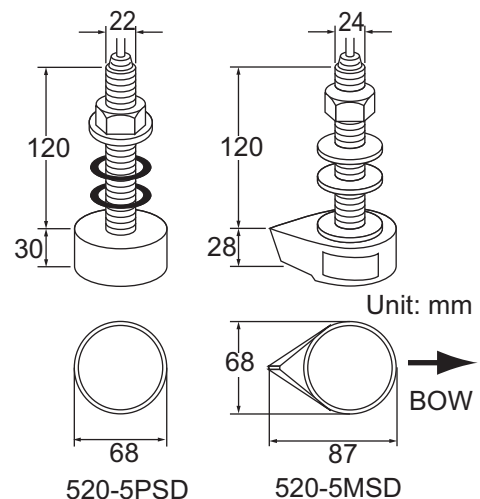
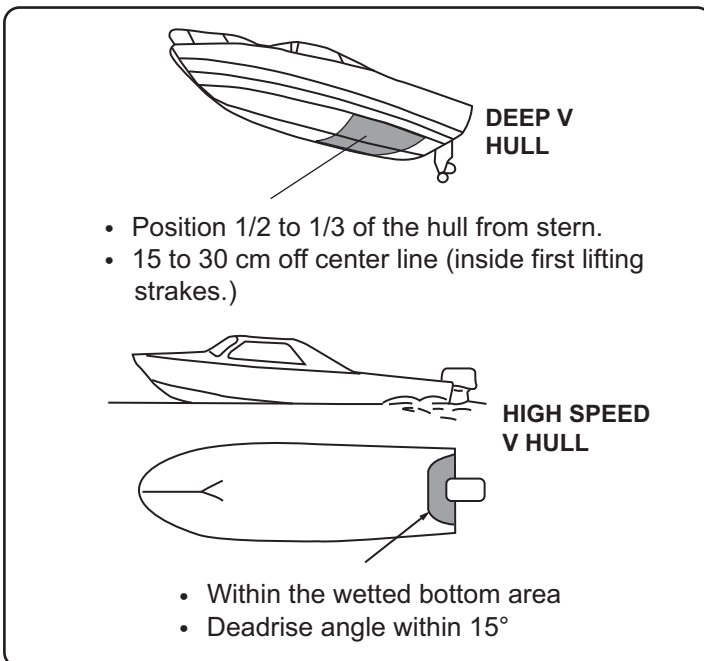

### Installation procedure

1. With the boat hauled out of the water, mark the location chosen for mounting the transducer on the bottom of the hull.
2. If the hull is not level within 15° in any direction, fairing blocks made out of teak should be used between the transducer and hull, both inside and outside, to keep the transducer face parallel with the water line. Fabricate the fairing block as shown below and make the entire surface as smooth as possible to provide an undisturbed flow of water around the transducer. The fairing block should be smaller than the transducer itself to provide a channel to divert turbulent water around the sides of the transducer rather than over its face.

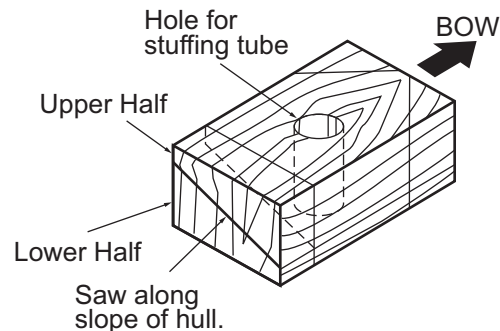

3. Drill a hole just large enough to pass the threaded stuffing tube of the transducer through the hull, making sure it is drilled vertically.
4. Apply a sufficient amount of high quality caulking compound to the top surface of the transducer, around the threads of the stuffing tube and inside the mounting hole (and fairing blocks if used) to ensure watertight mounting.
5. Mount the transducer and fairing blocks and tighten the locknut. Be sure that the transducer is properly oriented and its working face is parallel to the waterline.

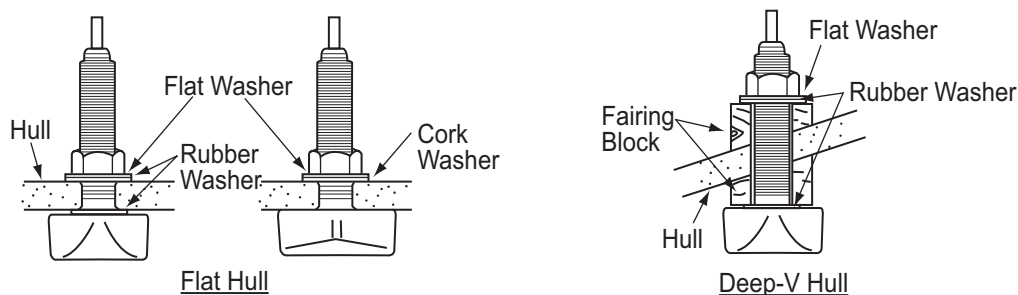

**Note:** Do not over-stress the stuffing tube and locknut through excessive tightening, since the wood block will swell when the boat is placed in the water. It is suggested that the nut be tightened lightly at installation and re-tightened several days after the boat has been launched.

### Transducer preparation

Before putting your boat in water, wipe the face of the transducer thoroughly with a detergent liquid soap. This will lessen the time necessary for the transducer to have good contact with the water. Otherwise the time required for complete "saturation" will be lengthened and performance will be reduced.

**DO NOT** paint the transducer. Performance will be affected.

## 1. MOUNTING

### 1.4.2 How to install a transducer in the transom

The optional transom mount transducer is very commonly employed, usually on relatively small I/O or outboard boats. Do not use this method on an inboard motor boat because turbulence is created by the propeller ahead of the transducer.

DO NOT over-tighten screws, to prevent damage to the transducer.

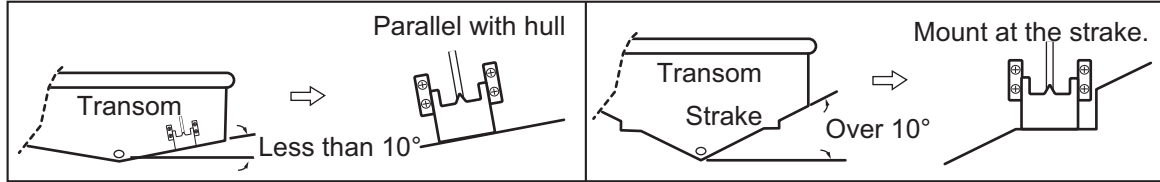

#### Installation procedure

A suitable mounting location is at least 50 cm away from the engine and where the water flow is smooth.

1. Drill four pilot holes for self-tapping screw (5x20) in the mounting location.
2. Coat the threads of the self-tapping screws (5x14) for the transducer with marine sealant for waterproofing. Attach the transducer to the mounting location with the self-tapping screws.
3. Adjust the transducer position so the transducer faces right to the bottom. If necessary, to improve water flow and minimize air bubbles staying on the transducer face, incline the transducer about 5° at the rear. This may require a certain amount of experimentation for fine tuning at high cruising speeds.
4. Tape the location shown in the figure below.

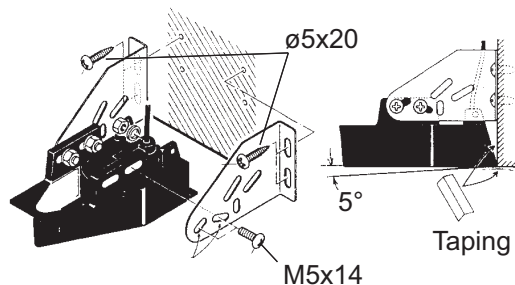

5. Fill the gap between the wedge front of the transducer and transom with epoxy material to eliminate any air spaces.

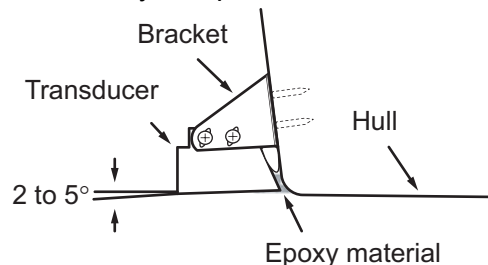

6. After the epoxy hardens, remove the tape.

### 1.4.3 How to install a transducer from inside the hull

The transducer may also be installed inside the hull on FRP boats. However, this installation method affects the ability to detect the seabed, fish and other objects because the ultrasound pulse is weakened when it passes through the hull.

**Note:** This mounting method should not be used to mount transducers that support the RezBoost™, ACCU-FISH™ and/or Bottom Discrimination Display feature, since performance is greatly degraded.

#### Necessary tools

The following tools are required:

- Sandpaper (#100)
- Marine sealant
- Water-filled plastic bag

#### Remarks on installation

- Do the installation with the ship moored at a dock, etc. The water depth should be 6.5 to 32 feet (2 to 10 meters).
- Turn off the engine.
- Do not power the unit with the transducer in the air, to prevent damage to the transducer.
- Do not use this method on a double layer hull.
- Before attaching the transducer to the hull, check that the site is suitable, by following steps 1 to 3 in the installation procedure below.

#### Installation procedure

The attenuation of the ultrasound pulse varies with the thickness of the hull. Select a location where attenuation is the lowest.

1. Select 2-3 locations considering the four points mentioned below.
  - Mount the transducer at a location 1/2 to 1/3 of the length of your boat from the stern.
  - The mounting location is between 15 to 50 cm from the centerline of the hull.
  - Do not place the transducer over hull struts or ribs which run under the hull.
  - Avoid a location where the rising angle of the hull exceeds 15°, to minimize the effect of the boat's rolling.
2. Decide the most suitable site from the locations selected.
  - 1) Connect the power cable and transducer cable to the display unit.
  - 2) Put the transducer into water-filled plastic bag. Press the transducer against the chosen site.
  - 3) Tap  (power switch) to turn the power on.
  - 4) After the startup procedure completes (approx. 90 seconds), the last used display appears. Tap the [Home] icon to show the home screen and display mode settings. See section 3.3 for how to use the menu.
  - 5) Drag the menu to show [Sounder] in the menu, then tap [Sounder].
  - 6) Drag the [Sounder] menu to show the [SOUNDER INITIAL SETUP] menu.
  - 7) Tap [Fish Finder Source].

## 1. MOUNTING

- 8) Confirm the available fish finder from the list of available sounders, then tap the appropriate fish finder. For the purpose of this example, the default setting [TZT2BB] (internal sounder) is selected as the source.
  - 9) Tap the [<] icon to return to the [Sounder] menu
  - 10) Drag the [Sounder] menu to show the [SOUNDER INITIAL SETUP] menu.
  - 11) Tap [Transducer Setup] → [Transducer Setup Type].
  - 12) Tap [Model], then tap the [<] icon to return to [Transducer Setup] menu.
  - 13) Tap [Model Number], drag the menu to show your transducer model, then tap the transducer model number.
  - 14) Tap the [<] icon twice to return to the [Sounder] menu, then drag the menu to show the [SOUNDER INITIAL SETUP] menu.
  - 15) At the [Transmission Power] menu item, set the transmission power to a level of [2].
  - 16) Drag the menu to show [Sounder Transmit], then tap [Sounder Transmit].  
Check if the bottom echo appears on the right side of the screen, in the display area.  
If no bottom echo appears, repeat the procedure until a suitable location is found.
  - 17) When a suitable installation location is found, turn the power off.
3. Remove the transducer from the plastic bag and wipe the face of transducer with a cloth to remove water and any foreign material. Lightly roughen the face with #100 sandpaper. Also, use the sandpaper to roughen the inside of the hull where the transducer is to be mounted.
  4. Wipe off any sandpaper dust from the face of the transducer.
  5. Dry the face of the transducer and the hull. Coat the transducer face and mounting location with marine sealant. Hardening begins in approx. 15 to 20 minutes so do this step without delay.
  6. Attach the transducer to the hull. Press the transducer firmly down on the hull and gently twist it back and forth to remove any air which may be trapped in the marine sealant.
  7. Support the transducer with a piece of wood to keep it in place while the sealant is drying. It takes 24 to 72 hours to harden completely.
  8. Turn the power on and change the menu setting as shown below. See section 3.3 for how to use the menu.
    - 1) Tap the [Home] icon to show the home screen and display mode settings.
    - 2) Drag the menu to show [Sounder] in the menu, then tap [Sounder].
    - 3) Drag the [Sounder] menu to show the [SOUNDER INITIAL SETUP] menu.
    - 4) At the [Transmission Power] menu item, set the transmission power to a level of [10].
    - 5) Adjust the Bottom Level and Gain Offset settings as shown in the table below.

Menu Item	Setting
Bottom Level HF	-40
Bottom Level LF	-40
Gain Offset HF	20
Gain Offset LF	20

### 1.4.4 How to install a triducer

DO NOT over-tighten screws, to prevent damage to the transducer.

#### **525STID-MSD**

The optional triducer 525STID-MSD is designed for thru-hull mounting.

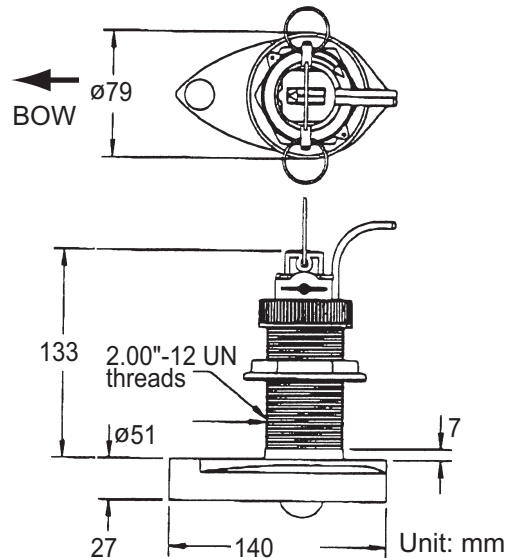

#### **525STID-PWD**

The optional transom mount triducer 525STID-PWD can be installed by the thru-hull method or the inside-hull method.

#### ***Pretest for speed and temperature***

Connect the sensor to the instrument and spin the paddlewheel. Check for a speed reading and the approximate air temperature. If there is no reading, return the sensor to your place of purchase.

#### ***Tools and materials required***

- Scissors
- Safety goggles
- Electric drill
- Drill bit:
  - For bracket holes: 4 mm, #23, or 9/64"
  - For fiberglass hull: chamfer bit (preferred), 6 mm, or 1/4"
  - For transom hole: 9 mm or 3/4" (optional)
  - For cable clamp holes: 3 mm or 1/8"
- Straight edge
- Pencil
- Water-based anti-fouling paint (mandatory in salt water)
- Masking tape
- Dust mask
- Screwdrivers
- Marine sealant
- Cable ties

## 1. MOUNTING

### Mounting location

To ensure the best performance, the sensor must be submerged in aeration-free and turbulence-free water. Mount the sensor close to the centerline of your boat. On slower heavier displacement hulls, positioning it farther from the centerline is acceptable. Allow adequate space above the bracket for it to release and rotate the sensor upward.

**Note 1:** Do not mount the sensor in an area of turbulence or bubbles: near water in-take or discharge openings; behind strakes, struts, fittings, or hull irregularities; behind eroding paint (an indication of turbulence).

**Note 2:** Avoid mounting the sensor where the boat may be supported during trailering, launching, hauling, and storage.

**Note 3:** For single drive boat, mount on the starboard side at least 75 mm (3") beyond the swing radius of the propeller, as shown in the right figure.

**Note 4:** For twin drive boat, mount between the drives.

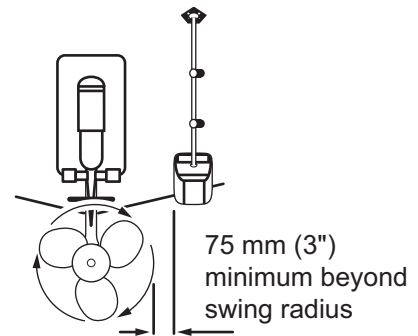
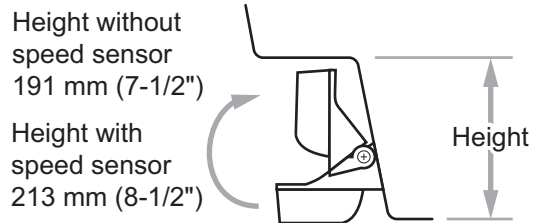

### How to install the bracket

1. Cut out the installation template (enclosed with transducer) along the dotted line.
2. At the selected location, position the template, so the arrow at the bottom is aligned with the bottom edge of the transom. Being sure the template is parallel to the waterline, tape it in place.

**Warning:** Always wear safety goggles and a dust mask.

3. Using a 4 mm, #23, or 9/64" bit, drill three holes 22 mm (7/8") deep at the locations indicated. To prevent drilling too deeply, wrap masking tape around the bit 22 mm (7/8") from the point.

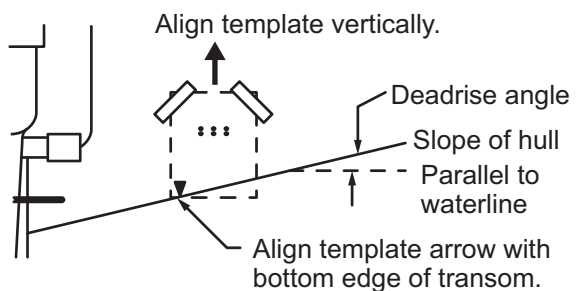

**Fiberglass hull:** Minimize surface cracking by chamfering the gelcoat. If a chamfer bit or countersink bit is not available, start drilling with a 6mm or 1/4" bit to a depth of 1 mm (1/16").

4. If you know your transom angle, the bracket is designed for a standard 13° transom angle.
  - 11° to 18° angle: No shim is required. Skip to step 3 in "Adjustments".
  - Other angles: The shim is required. Skip to step 2 of "Adjustments".

If you do not know the transom angle, temporarily attach the bracket and sensor to the transom to determine if the plastic shim is needed.



- Using the three #10 x 1-1/4" self-tapping screws, temporarily screw the bracket to the hull. DO NOT tighten the screws completely at this time. Follow the step 1-4 in "How to attach the sensor to the bracket", before proceeding with "Adjustments".

### Adjustments

- Using a straight edge, sight the underside of the sensor relative to the underside of the hull. The stern of the sensor should be 1-3 mm (1/16-1/8") below the bow of the sensor or parallel to the bottom of the hull.

**Note:** Do not position the bow of the sensor lower than the stern because aeration will occur.

- To adjust the sensor's angle relative to the hull, use the tapered plastic shim provided. If the bracket has been temporarily fastened to the transom, remove it. Key the shim in place on the back of the bracket.

**2°-10° transom angle (stepped transom and jet boats):** Position the shim with the tapered end down.

**19°-22° transom angle (small aluminum and fiberglass boats):** Position the shim with the tapered end up.

- If the bracket has been temporarily fastened to the transom, remove it. Apply marine sealant to the threads of the three #10 x 1-1/4" self-tapping screws to prevent water seeping into the transom. Screw the bracket to the hull. Do not tighten the screws completely at this time.

- Repeat step 1 to ensure that the angle of the sensor is correct.

**Note:** Do not position the sensor farther into the water than necessary to avoid increasing drag, spray, and water noise and reducing boat speed.

- Using the vertical adjustment space on the bracket slots, slide the sensor up or down to provide a projection of 3 mm (1/8"). Tighten the screws.

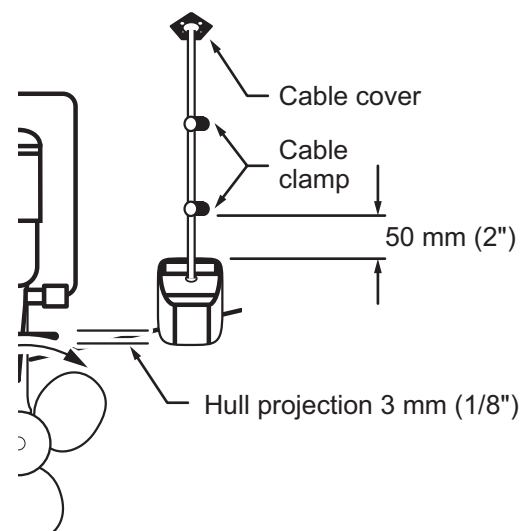

## 1. MOUNTING

### ***How to attach the sensor to the bracket***

1. If the retaining cover near the top of the bracket is closed, open it by depressing the latch and rotating the cover downward.
2. Insert the sensor's pivot arms into the slots near the top of the bracket.
3. Maintain pressure until the pivot arms click into place.
4. Rotate the sensor downward until the bottom snaps into the bracket.
5. Close the retaining cover to prevent the accidental release of the sensor when your boat is underway.

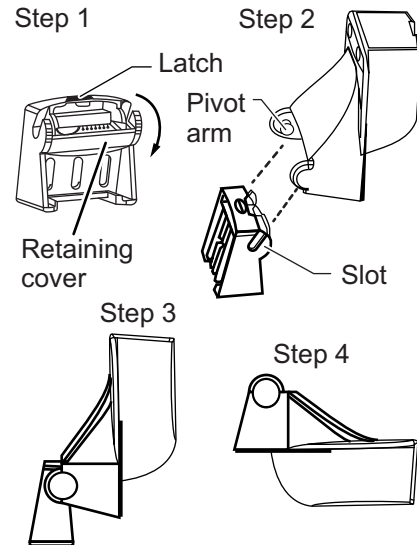

### ***How to route the cable***

Route the sensor cable over the transom, through a drain hole, or through a new hole drilled in the transom above the waterline.

Never cut the cable or remove the connector; this will void the warranty. Always wear safety goggles and a dust mask.

1. If a hole must be drilled, choose a location well above the waterline. Check for obstructions such as trim tabs, pumps, or wiring inside the hull. Mark the location with a pencil. Drill a hole through the transom using a 19 mm or 3/4" bit (to accommodate the connector).
2. Route the cable over or through the transom.
3. On the outside of the hull secure the cable against the transom using the cable clamps. Position a cable clamp 50 mm (2") above the bracket and mark the mounting hole with a pencil.
4. Position the second cable clamp halfway between the first clamp and the cable hole. Mark this mounting hole.
5. If a hole has been drilled in the transom, open the appropriate slot in the transom cable cover. Position the cover over the cable where it enters the hull. Mark the two mounting holes.
6. At each of the marked locations, use a 3 mm or 1/8" bit to drill a hole 10 mm (3/8") deep. The prevent drilling too deeply, wrap masking tape around the bit 10 mm (3/8") from the point.
7. Apply marine sealant to the threads of the #6 x 1/2" self-tapping screw to prevent water from seeping into the transom. If you have drilled a hole through the transom, apply marine sealant to the space around the cable where it passes through the transom.
8. Position the two cable clamps and fasten them in place. If used, push the cable cover over the cable and screw it in place.
9. Route the cable to the display unit being careful not to tear the cable jacket when passing it through the bulkhead(s) and other parts of the boat. To reduce electrical interference, separate the sensor cable from other electrical wiring and "noise" sources. Coil any excess cable and secure it in place with cable ties to prevent damage.

# 2. WIRING

## 2.1 Interface Connections Overview

The figure below shows the connections available on the processor unit. For detailed information on connections, see the interconnection diagram at the back of this manual.

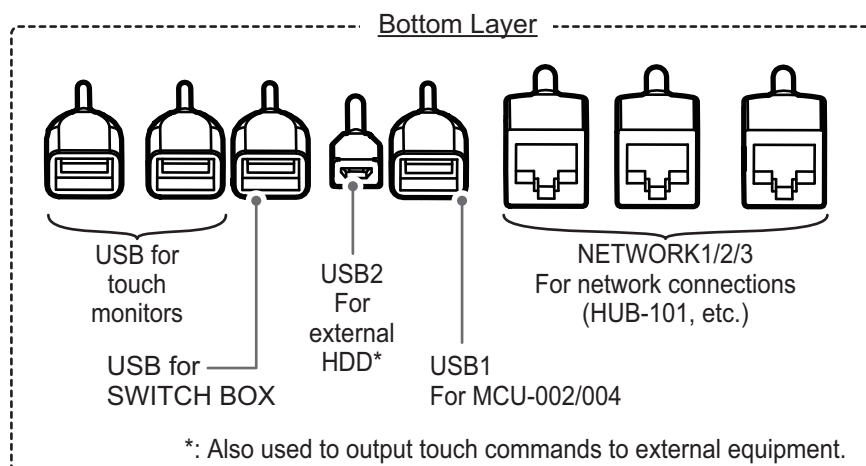
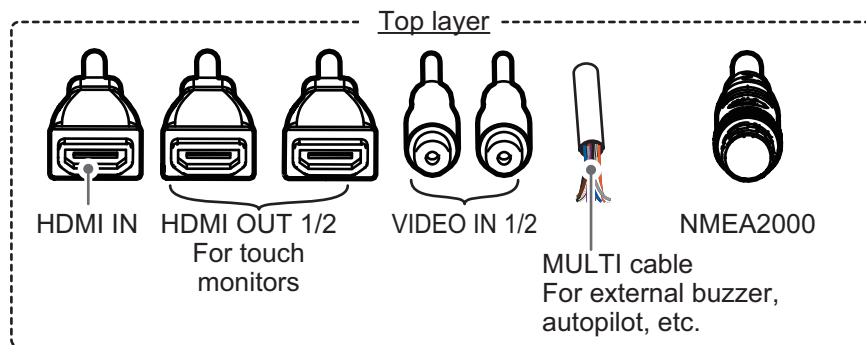
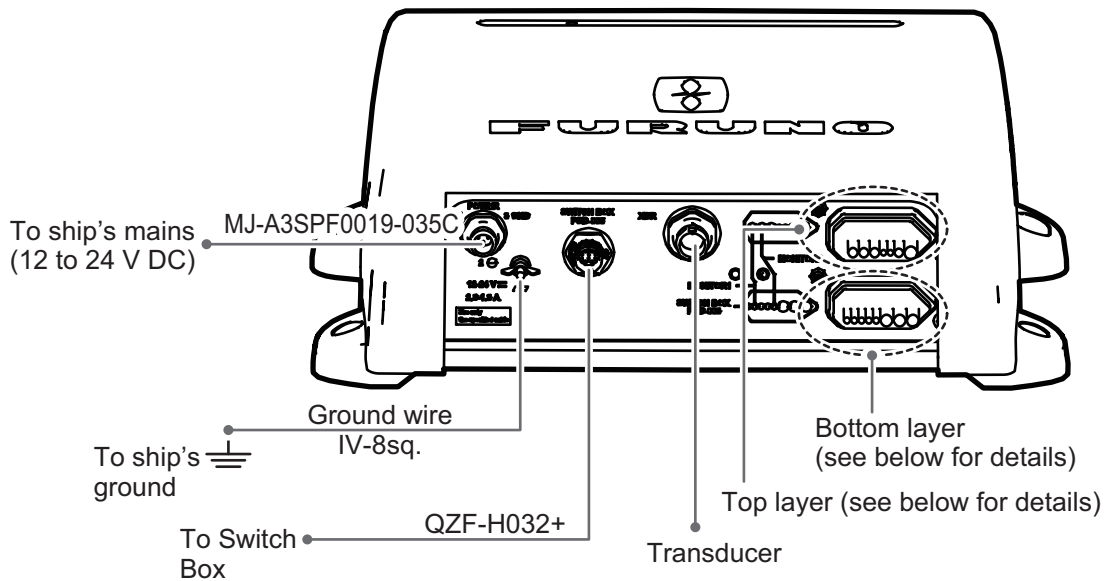

## 2.2 How to Protect the Interface Connections

All cable connectors not inside the equipment, whether exposed to weather or otherwise, should be waterproofed and secured after making the connection. By securing and waterproofing the connections, the IPx2 rating can be maintained. Disconnections/loosened connections are also prevented.

To waterproof and secure each connection, refer to the procedures outlined below.

### For completed connections

- 1) Wrap the connection, covering approx. 30 mm to either side, with self-vulcanizing tape.



- 2) Wrap a second layer of self-vulcanizing tape in the opposite direction.

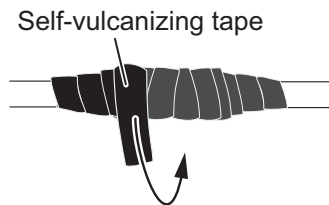

- 3) Wrap vinyl tape over the self-vulcanizing tape.  
The vinyl tape should cover approx. 50 mm to either side of the connection.

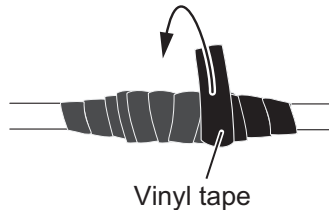

- 4) Wrap a second layer of vinyl tape in the opposite direction.

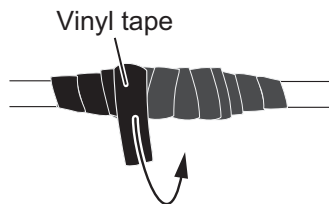

- 5) Bind the tape ends with cable ties to prevent the tape from unraveling.

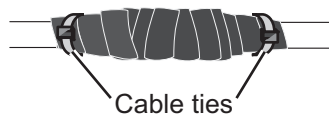

**For unused cables**

- 1) Cover the loose end of the cable connector with self-vulcanizing tape.

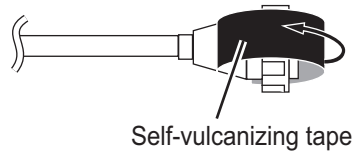

- 2) Wrap the connector with a layer of vulcanizing tape, covering approx. 50 mm of the connected cable.

**Note:** Confirm that the connector is covered.

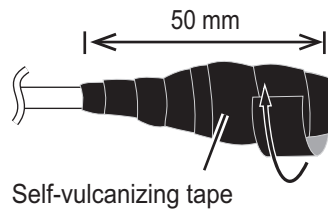

- 3) Wrap vinyl tape over the self-vulcanizing tape on the connector.



- 4) Wrap the connector with a layer of vinyl tape.

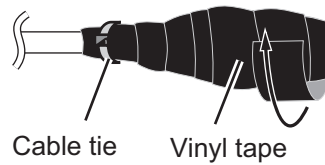

- 5) Bind the tape end with a cable tie to prevent the tape from unraveling.



## 2.3 MULTI Cable

The MULTI cable is used for connection to the power switch, event switch, external buzzer. The cable has 11 wires, connect these wires referring to the table below.

Wire color	Connect to....
White	NMEA - TD_A
Blue	NMEA - TD_B
Gray	External buzzer ON/OFF
Red	External buzzer power (12 V)
Orange	Event switch (MOB, etc.)
Black	Event Switch Ground
Purple	Power Switch
Brown	DC_N
White/Red	Unused
White/Black	
Black (Braided shield)	Ship's ground

### 2.3.1 How to isolate and secure unused wires

1. Cut the outer and inner sheaths lengthwise. Take care not to cut the wires.
2. Fold back the outer sheath, then fold back the inner sheath, covering the outer sheath.
3. Individually isolate unused wires using vinyl tape, then secure the unused wires as shown in the figure below.

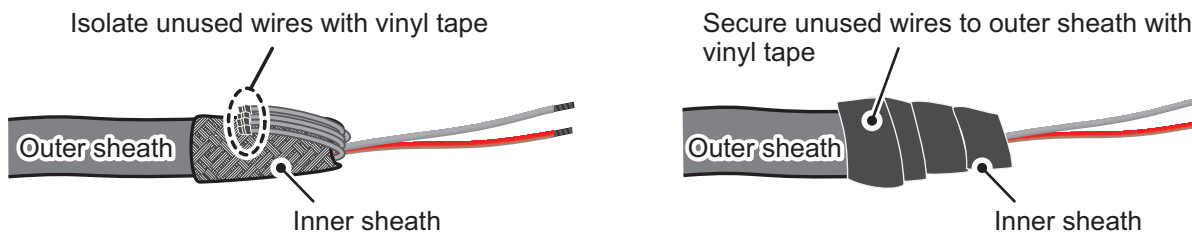

### 2.3.2 How to set up NMEA0183 data output

**Note:** To set up data output for NMEA0183 equipment, see "NMEA0183 sentence output" on page 2-14.

1. Cut the connector at the end of the NMEA0183 equipment cable to an appropriate length for your installation.
2. Referring to the figure below, place heat shrink tubes on the wires, then solder the connection point.
3. Move the heat shrink tubes to the soldered connection, then apply heat to the tubes.

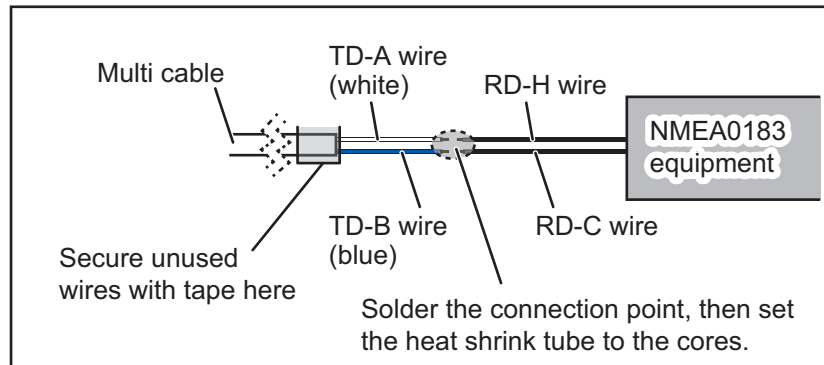

4. Isolate and secure unused wires as shown in section 2.2.
5. Referring to "[DATA ACQUISITION] menu" on page 3-8, set up the interface as required.

### 2.3.3 How to connect the external buzzer

Connect the optional external buzzer (OP03-136) following the procedure below.

**Note:** The external buzzer does not require menu settings.

1. Cut the XH connector at the end of the external buzzer cable to an appropriate length for your installation.
2. Referring to the figure below, place heat shrink tubes on the wires, then solder the connection point.
3. Move the heat shrink tubes to the soldered connection, then apply heat to the tubes.
4. Secure the buzzer with double-sided tape (local supply) or two self-tapping screws (3×15 or 3×20, local supply).
5. Secure any unused wires, referring to section 2.3.1.

External buzzer connection example

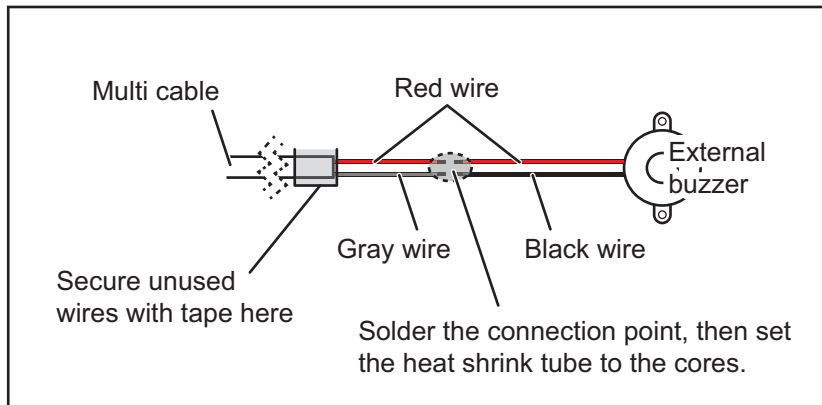

### 2.3.4 How to connect and set up the event switch

**Note:** The event switch does not require menu settings.

1. Referring to the figure below, connect, then solder, the orange wire and black wire from the MULTI cable to the event switch.
2. Secure any unused wires, referring to section 2.3.1.

Event switch connection example

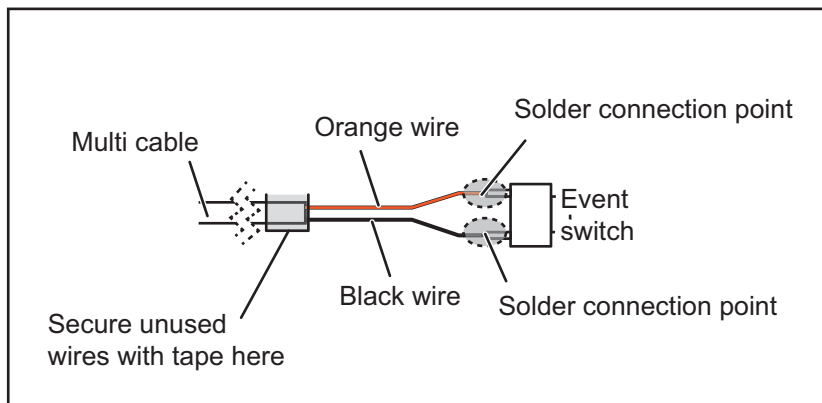

3. Referring to "[Initial Setup] menu (Other menu items)" on page 3-9, set up the event switch.



## 2.4 DRS Radar Sensor Connections

Depending on your configuration, a separate power supply may be required for your radar sensor.

The figures below show connection examples with radar sensors which are compatible with the TZT2BB.

For details regarding connection and cables required for connection with the radar sensor, see the radar sensor's installation manual.

Connection example for radome sensors

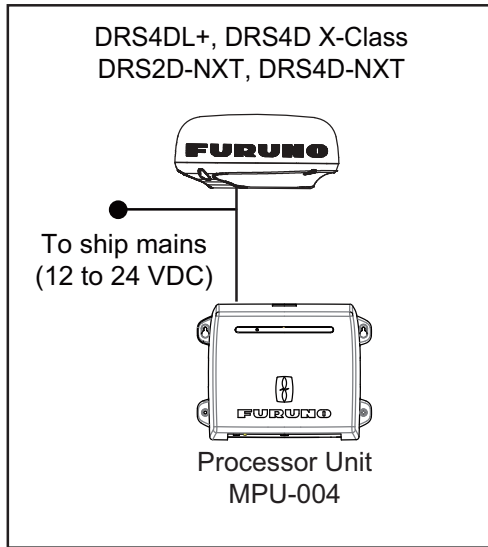

Connection example for open-array sensors

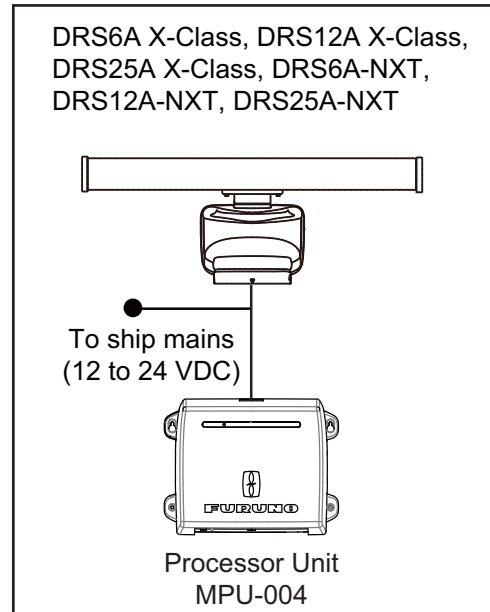

**Note:** The Ethernet hub HUB-101 (available as an optional extra) is required for configurations comprising DRS4DL, DRS4DL+, DRS4D NXT, DRS6A X-Class, DRS6A NXT, DRS12A X-Class or DRS25A X-Class, and networked with sensors via LAN.

## 2.5 Network Connections

Like previous NavNet series equipment, the TZT2BB is able to share Radar and Fish Finder images, and other information, across a TCP/IP Ethernet connection. Up to four TZT2BBs may be connected to the same network at one time. The TZT2BB is equipped with three network connectors (RJ45).

IP cameras are network devices that connect directly to a HUB or directly to the TZT2BB. The IP camera is should meet the following requirements.

Video Compression	Resolution	Compression Level
H.264/MPEG-4	800×600	30

Up to four IP cameras can be connected to one NavNet TZtouch2 network. At this time, only AXIS IP cameras that support MPEG4 video are functional in the network. For more details, see the operator's manual for AXIS models.

## 2.6 USB Connections

The TZT2BB has five USB connectors which can be used for the following:

- USB for HDMI OUT1/2: For HDMI touch monitors.
- USB for SWITCH BOX: For connection to the PSD-003.
- USB1: For connection to MCU-002/004 control units.
- USB2: For connection to an external HDD (via Micro-USB connector) or touch command output to external equipment.

## 2.7 VIDEO IN, HDMI IN/OUT Connections

The TZT2BB has two HDMI OUT connectors for touch monitors, one HDMI IN connector and two VIDEO IN connectors. For the location of each of these connectors, see the figure in section 2.1.

### Analog video input

### NOTICE

When using analog video, use a locally-arranged IP converter or rHDMI converter, and display the video on a network camera or HDMI input video.

PAL format analog video can be directly input to this unit through each VIDEO IN1, VIDEO IN2 connector. Analog video is only displayed on the NavNet TZtouch2 device where it is being input.

Additionally FLIR cameras may be connected to the TZT2BB. Connect the Video Out cable from the camera to the VIDEO IN1/2 connector on the TZT2BB.

**Note 1:** An adapter may be required for connection to some camera models.

**Note 2:** A PAL converter (locally arranged) is required to input NTSC format analog video.

Cameras may be set up using the appropriate menu item on the [Camera] menu, accessed from the [Settings] menu. For details on camera setup, see the operator's manual (OME-44870-x).

**Digital video input (HDMI)**

The TZT2BB accepts and can display the following HDMI signal configurations.

Resolution	Vertical Freq.	Horizontal Freq.	Pixel Clock
1920×1080	60 Hz	67.5 kHz	148.5 MHz
1280×1024	60 Hz	64.0 kHz	108.0 MHz
1280×720	60 Hz	45.0 kHz	74.25 MHz
1024×768	60 Hz	48.4 kHz	65.0 MHz

**Note 1:** For dual monitor configurations, only one monitor can input HDMI to the TZT2BB.

**Note 2:** Interlaced input is not supported by the TZT2BB.

Connect the external monitor's HDMI cable to the HDMI IN cable on the TZT2BB.

The HDMI input may be set up using the appropriate menu item on the [Camera] menu, accessed from the [Settings] menu. For details on camera setup, see the operator's manual (OME-44870-x).

**Video out (external HDMI monitors)**

You can connect an HDMI monitor to the TZT2BB. If the monitor is a touch monitor, you can also operate the TZT2BB from the monitor.

The TZT2BB is compatible with wide-screen monitors which meet the following requirements:

Resolution	Vertical Freq.	Horizontal Freq.	Pixel Clock
1920×1080	60 Hz	67.5 kHz	148.5 MHz
1280×1024	60 Hz	64.0 kHz	108.0 MHz
1024×768	60 Hz	48.4 kHz	65.0 MHz

Connect the monitor's HDMI IN cable to either HDMI OUT1 or HDMI OUT2 on the TZT2BB. For touch monitors, connect the USB cable on the monitor to the appropriate USB cable on the TZT2BB (USB for HDMI OUT1/2).

## 2.8 CAN bus (NMEA2000 Connector)

The TZT2BB has one CAN bus connector (micro style connector). All NavNet TZtouch2 units must be connected to the same CAN bus backbone. To connect the TZT2BB with a DRS (radar sensor), use “Ethernet Bridging” to link the DRS CAN bus and the NavNet TZtouch2 CAN bus data (see section 2.4).

### What is CAN bus?

CAN bus is a communication protocol (NMEA2000 compliant) that shares multiple data and signals through a single backbone cable. You can simply connect any CAN bus devices onto the backbone cable to expand your network on-board. With CAN bus, IDs are assigned to all the devices in the network, and the status of each sensor in the network can be detected. All the CAN bus devices can be incorporated into the NMEA2000 network. For detailed information about CAN bus wiring, see “FURUNO CAN bus Network Design Guide” (Type: TIE-00170) on Tech-Net.

### 2.8.1 How to connect the TZT2BB to CAN bus equipment

**Note:** When using a DC-DC converter to supply power to the NMEA200 network externally, use an isolated converter.

Below is an example of two TZT2BB units, connected via CAN bus to CAN bus sensors.

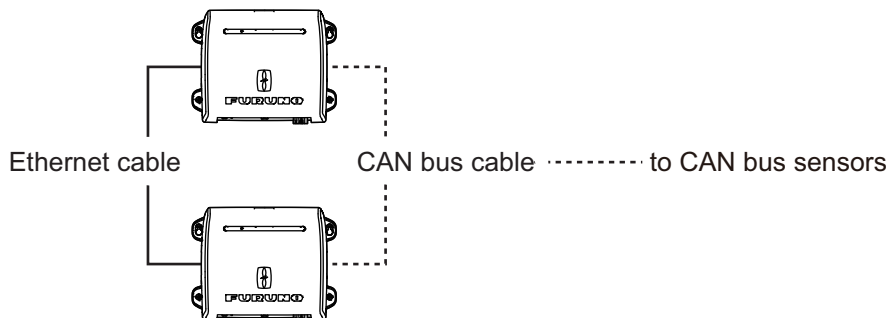

### 2.8.2 How to connect Yamaha engine(s)

When interfaced with Yamaha outboard engine(s) compatible with Command Link<sup>®</sup>, Command Link Plus<sup>®</sup> and Helm Master<sup>®</sup>, the TZT2BB can display engine information on a dedicated Yamaha engine status display.

#### How to connect the engine

The NavNet TZtouch2 connects to the Yamaha engine network via the Yamaha Interface Unit. Arrange the Yamaha Interface Unit through a local Yamaha representative.

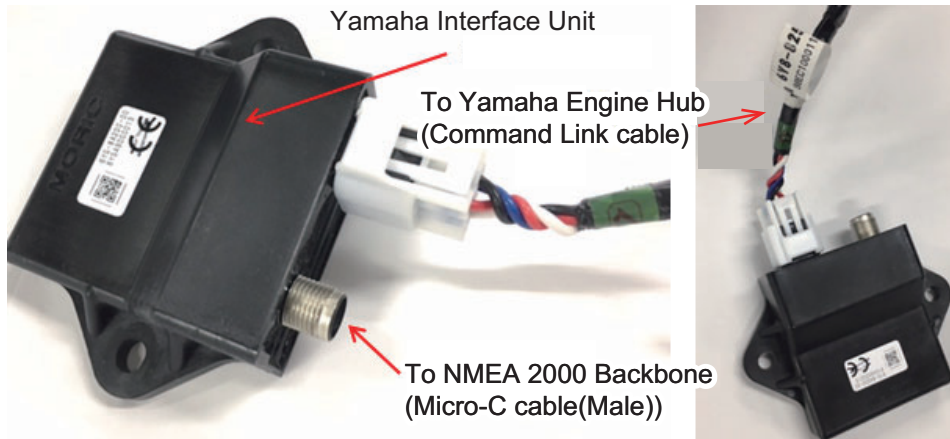

The Yamaha Engine Hub (Yamaha supply), which connects between the engine and the Yamaha Interface Unit, is also required.

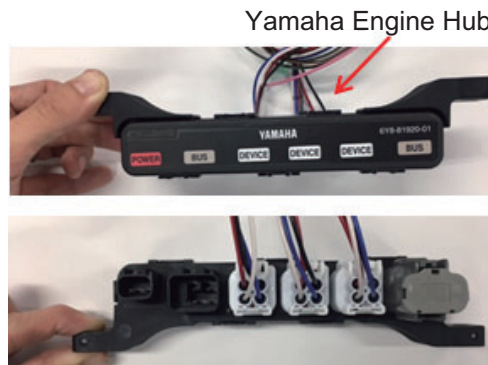

**Connection to TZT2BB**

Connect the Yamaha Interface Unit to the Yamaha Engine Hub.

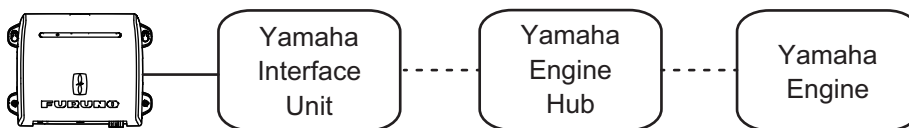

— : NMEA 2000  
 - - - : Command Link®/Command Link Plus®/Helm Master®

**How to set up the engine display**

Once the TZT2BB detects the Yamaha engine network, the engine can be set up on [Settings]→[Initial Setup]→[YAMAHA ENGINE SETUP]. See "[YAMAHA ENGINE SETUP] menu" on page 3-7 for details.

### 2.8.3 NMEA0183 equipment data input

**Note:** To output NMEA0183 data, see section 2.3.2.

To connect NMEA0183 equipment to the TZT2BB, use the CAN bus network via the optional NMEA data converter IF-NMEA2K2 (or IF-NMEA2K1). This NMEA connection can accept a baud rate of 4800 or 38400.

Heading input to the TZT2BB allows functions such as Radar Overlay and course stabilization (North up, Course up, etc.) in the radar operating modes. The NMEA0183 heading refresh rate needs to be 100 ms in order for any radar function to work properly. NMEA0183 heading can be accepted on any CAN bus port at a baud rate up to 38400 bps. In other words, data sent (IF-NMEA) and received (TZT2BB) must use the same baud rate for each individual data port.

**Note 1:** When using the ARPA function, set the heading refresh rate to 100 ms.

**Note 2:** For more information on connecting and wiring IF-NMEA2K2 or IF-NMEA2K1, refer to their respective installation manuals.

### 2.8.4 CAN bus (NMEA2000) input/output

#### Input PGN

PGN	Description
059392	Acknowledgment
059904	Request
060928	Address Claim
126208	NMEA-Request Group Function
	NMEA-Command Group Function
	NMEA-Acknowledge Group Function
126464	Receive/Transmit PGN's Group Function
126992	System Time
126996	Product Information
127237	Heading/Track Control
127245	Rudder
127250	Vessel Heading
127251	Rate of Turn
127257	Attitude
127258	Magnetic Variation
127488	Engine Parameters, Rapid Update
127489	Engine Parameters, Dynamic
127493	Transmission Parameters, Dynamic
127505	Fluid Level
128259	Speed
128267	Water Depth
129025	Position, Rapid Update
129026	COG & SOG, Rapid Update
129029	GNSS Position Data
129033	Local Time Offset
129038	AIS Class A Position Report
129039	AIS Class B Position Report
129040	AIS Class B Extended Position Report

PGN	Description
129041	AIS Aids to Navigation (AtoN) Report
129291	Set & Drift, Rapid Update
129538	GNSS Control Status
129540	GNSS Satellites in View
129793	AIS UTC and Date Report
129794	AIS Class A Static and Voyage Related Data
129798	AIS SAR Aircraft Position Report
129808	DSC Call Information
129809	AIS Class B "CS" Static Data Report, Part A
129810	AIS Class B "CS" Static Data Report, Part B
130306	Wind Data
130310	Environmental Parameters
130311	Environmental Parameters
130312	Temperature
130313	Humidity
130314	Actual Pressure
130316	Temperature, Extended Range
130577	Direction Data
130578	Vessel Speed Component

### Output PGN

The CAN bus output PGN setting (found under the [Initial Setup] menu) is global to the network. Note that only one NavNet TZtouch2 will output CAN bus data on the network at a time: the NavNet TZtouch2 which is powered ON first. If that display is turned OFF, another will take its place to output the data.

PGN	Description	Remarks	Output cycle (msec)
059392	Acknowledgment	For Certification Level A/B, Refusing output requirement	
059904	Request	For Certification Level A/B, Requiring output	
060928	Address Claim	For Certification Level A/B • Address autonomy • Receiving output requirement	
126208	NMEA-Request group function	For Certification Level A/+ $\alpha$ • Address autonomy • Receiving output requirement	
	NMEA-Command group function	For Certification Level A/+ $\alpha$ Changing the setting of other equipment	
	NMEA-Acknowledge group function	For Certification Level A/+ $\alpha$ Sending the confirmation for NMEA-Request group function and NMEA-Command group function	
126464	PGN List-Transmit PGN's group function	For Certification Level A/+ $\alpha$ Receiving output requirement	
	PGN List-Received PGN's group function	For Certification Level A/+ $\alpha$ Receiving output requirement	
126992	System Time	-	1000
126993	Heartbeat	-	
126996	Product Information	For Certification Level A/B Receiving output requirement	

## 2. WIRING

PGN	Description	Remarks	Output cycle (msec)
127250	Vessel Heading	-	100
127251	Rate of Turn	-	100
127257	Attitude	-	1000
127258	Magnetic Variation	-	1000
128259	Speed	-	1000
128267	Water Depth	-	1000
129025	Position, Rapid Update	-	100
129026	COG & SOG, Rapid Update	-	250
129029	GNSS Position Data	-	1000
129033	Local Time Offset	-	1000
129283	Cross Track Error	-	1000
129284	Navigation Data	-	1000
129285	Navigation-Route/WP Information	<ul style="list-style-type: none"> <li>• Outputs when waypoint is set/changed (own ship's position is required)</li> <li>• Outputs when receiving ISO request</li> </ul>	
130306	Wind Data	-	100
130310	Environmental Parameters	-	500
130312	Temperature	-	2000
130313	Humidity	Outputs when receiving the ISO request	2000
130314	Actual Pressure	-	2000
130316	Temp., Extended Range	-	2000

### **NMEA0183 sentence output**

The TZT2BB can output the following NMEA0183 sentence to external equipment on the same network. Note that all sentences listed here use the GP talker.

Sentence	Description
AAM	Waypoint Arrival Alarm
APB	Autopilot B Sentence Data
BOD	Bearing Origin to Destination
DBT	Depth Below Transducer
DPT	Depth
GGA	Global positioning system fix data
GLL	Geographic position (Latitude/Longitude)
GNS	GNSS fix data
GSA	Overall satellite data
GSV	Detailed satellite data
RMB	Recommended navigation data for GPS
RMC	Recommended minimum data for GPS
RTE	Route message
TLL	Target Latitude/Longitude
TTM	Tracked Target Message
VTG	Vector track and Speed Over the Ground (SOG)
WPL	Waypoint Location information
XTE	Measured cross-track error
ZDA	Date and time



## 2.9 Example System Configurations

### Basic plotter/fish finder installation

The FURUNO GP-330B is connected to the CAN bus backbone cable. The DFF3-UHD network fish finder is connected to the LAN port of the TZTBB using the standard supply cable MOD-WPAS0001-030+(3 m) and a junction box TL-CAT-012.

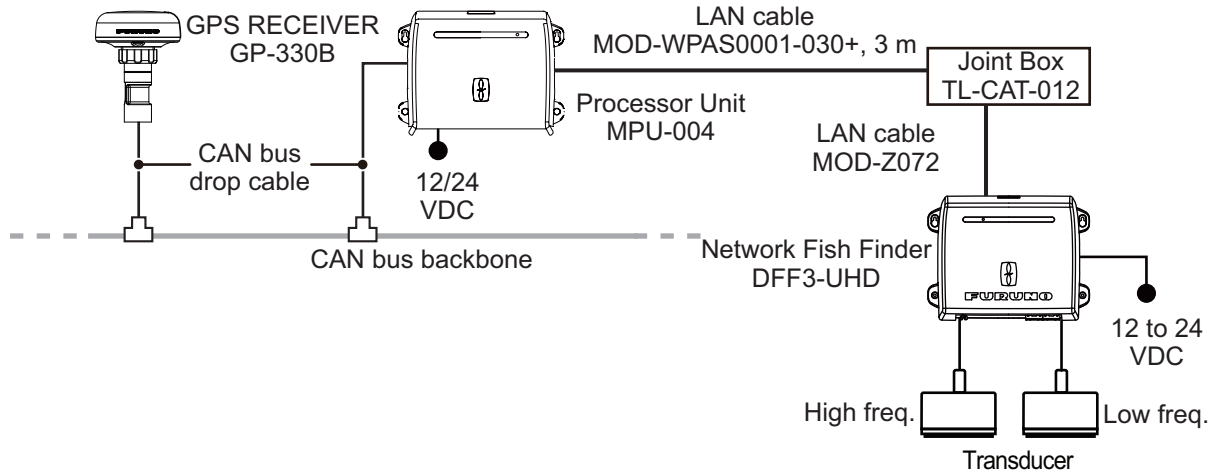

## 2. WIRING

### Mid/Large-size vessels (External GPS, Fish Finder, Radar)

This is a single station plotter/radar/fish finder installation. Connection to multiple sensors, such as the DFF3-UHD and DRS series, requires an Ethernet hub such as the HUB-101.

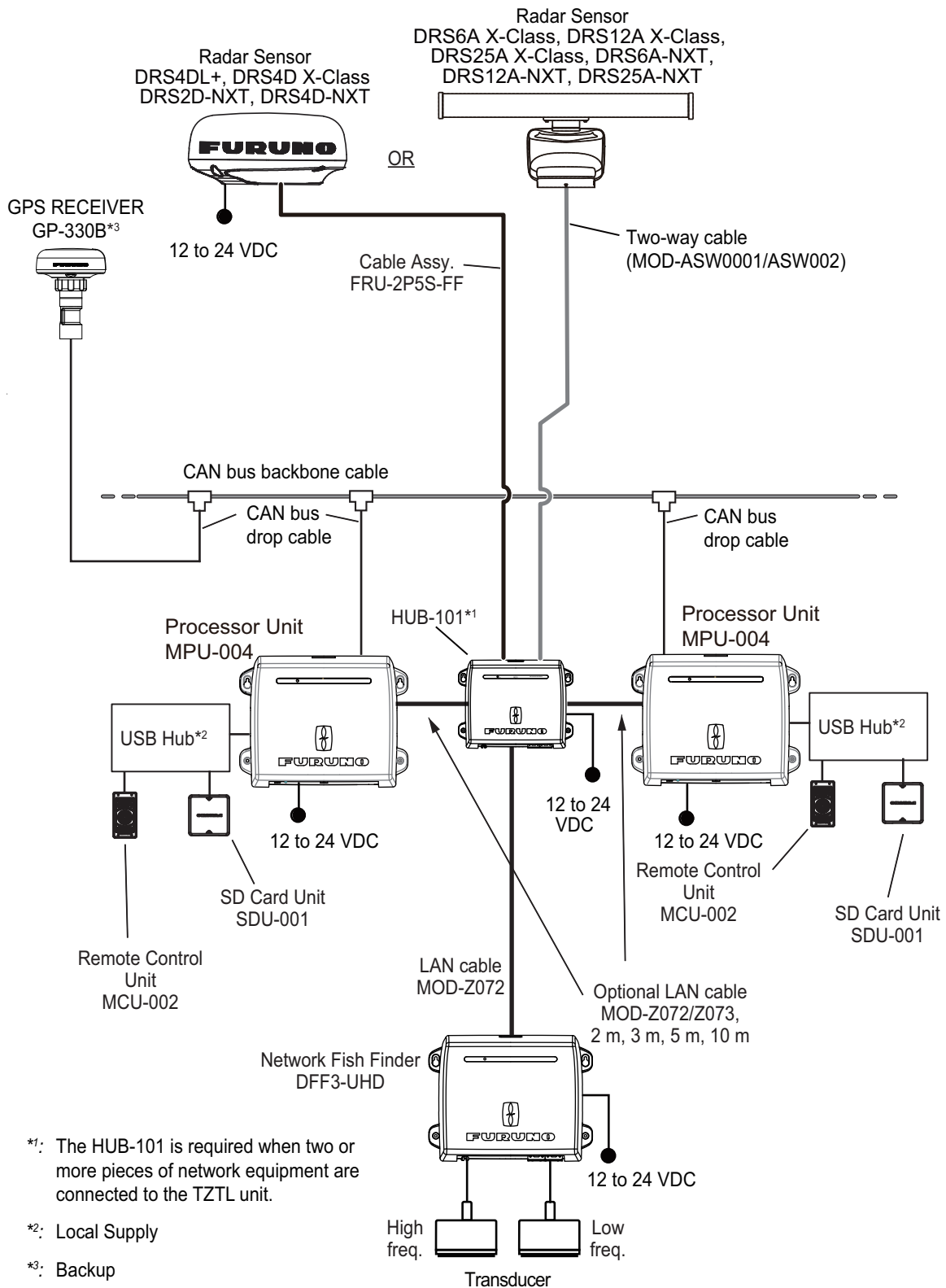





# 3. EQUIPMENT SETUP

This chapter shows you how to set up your system according to the equipment you have connected.

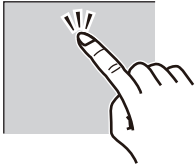
## Touch control description

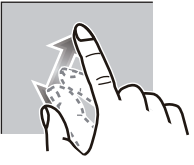

The touch control depends on the screen type. The basic operations to use during the installation setup are in the following table.

Operating by finger		Function
Tap		<ul style="list-style-type: none"><li>• Select a menu item.</li><li>• Select a setting option where there are multiple options.</li><li>• Select an object.</li><li>• Display the pop-up menu where available.</li></ul>
Drag		<ul style="list-style-type: none"><li>• Scroll the menu.</li></ul>
Pinch	 Increase range  Reduce range	Change the radar range.

### 3. EQUIPMENT SETUP

#### How to operate the menus

The following procedure shows how to use the menu system.



1. Press  (power switch) on the switch box to turn the power on.
2. After the startup process completes, the last used display appears and a warning message is displayed. After reading the message, tap [OK].
3. Tap the [Home] icon (  ) to show the home screen and display mode settings.

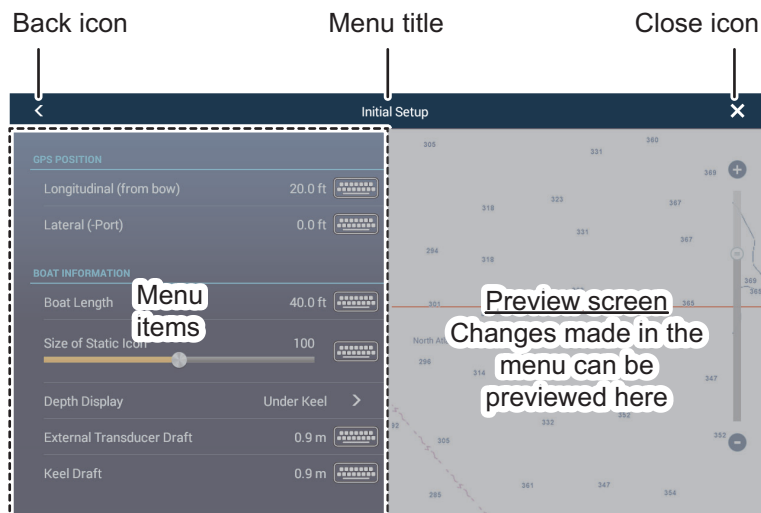

4. Tap [Settings] to open the [Settings] menu.
5. Drag the menu to show [Initial Setup], then tap [Initial Setup].



6. Depending on the menu item selected, the following operations are available:

- [ON]/[OFF] toggle switch.   
Tap to switch between [ON] and [OFF]. [ON] activates the function, [OFF] deactivates the function.
- Sidebar and keyboard icon.   
Drag the sidebar to adjust the setting. Settings may also be adjusted using the software keyboard for direct input.
- Keyboard icon.   
Referring to the figure on the following page, use the software keyboard to input alphabet or numeric characters.

7. Tap [Close] (Indicated as an "X") at the top right-hand side of the screen to exit.

## How to use the software keyboard

### Numeric software keyboard

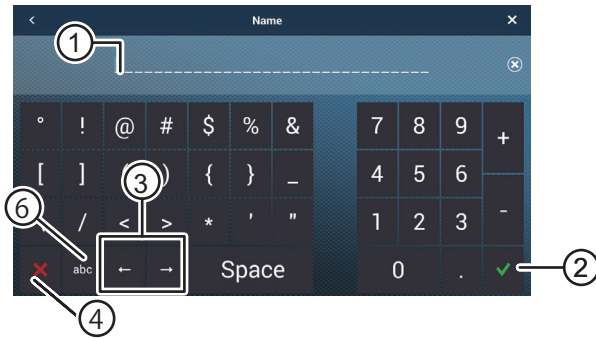

### Alphabet software keyboard



No.	Description
1	Cursor position is highlighted.
2	Enter button. Tap to complete character input and apply changes.
3	Cursor keys. Tap to move the cursor left/right.
4	Cancel button. Aborts character entry. No changes are applied.
5	Backspace/Delete. Tap to erase one character at a time.
6	Tap to switch between alphabet and numeric keyboards (where available).

## 3.1 How to Set Time Zone, Time Format and Language

Before setting up your equipment, select the time zone, language and units to use on your equipment as shown below.

1. Tap the [Home] icon to show the home screen and display mode settings.
2. Tap [Settings] to show the [Settings] menu.
3. Drag the menu to display the [General] menu item, then tap [General] on the main menu to show the [General] menu.
4. Drag the menu to show the [Local Time Offset] menu item, then tap [Local Time Offset] to show the numerical keyboard.
5. Input the time difference (using 15-minute intervals), then tap [✓].
6. Drag the menu to show the [Time Format] menu item, then tap [Time Format] to show the option window.
7. Select how to display time, in 12 or 24 hour format. [Auto] automatically inserts AM, PM indication in 24 hour clock, when the language is English.
8. Tap the [<] at the top left of the screen to return to the [General] menu.

### 3. EQUIPMENT SETUP

9. Drag the menu to display the [Language] menu item, then tap [Language] on the main menu to show the language options.

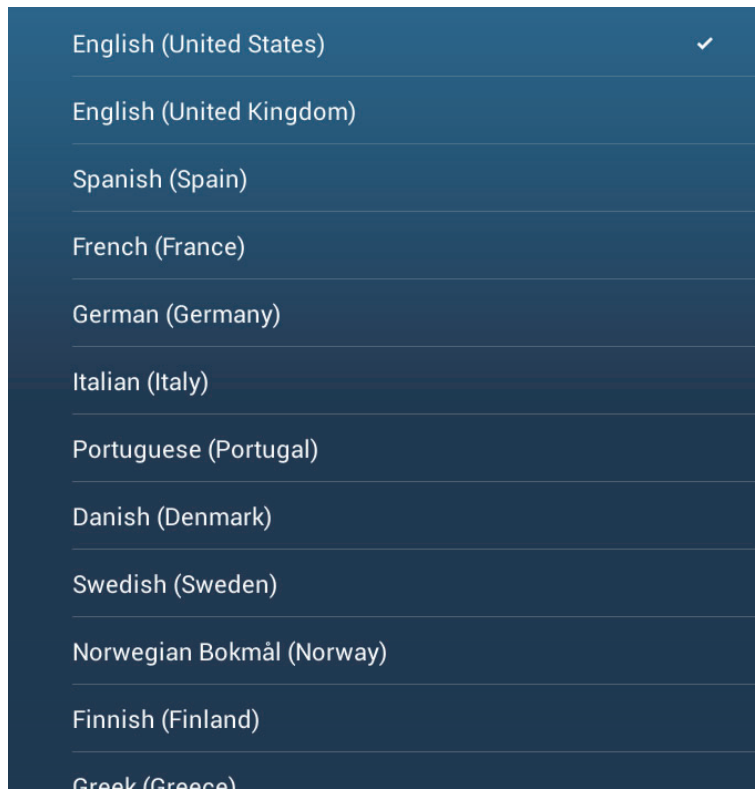

10. Tap the appropriate language to use. The unit will display a confirmation message. Tap [OK] to restart the unit and apply the new language settings. This process takes approximately five minutes to optimize the system for the new language setting. When the process is complete, the power switch color changes to orange. Tap the power switch to start the system.

## 3.2 How to Set Units of Measurement

1. Tap the [Home] icon to show the home screen and display mode settings.
2. Tap [Settings] to show the [Settings] menu.
3. Drag the main menu to display [Units], then tap [Units].
4. Referring to the table below, set the units to show on the display.

Menu item	Description	Options
[Bearing Display]	Adjust the bearing display format.	[Magnetic], [True]
[True Wind Calculation Reference]	Set the reference for calculating true wind speed/angle.	[Ground], [Surface]
[Position Format]	Set the display format for position (Latitude/Longitude).	[DDD°MM.mmmm'], [DDD°MM.mmm'], [DDD°MM.mm'], [DDD°MM'SS.ss"], [DDD.ddddd°], [Loran-C], [MGRS]
[Loran C Station & GRI]	Available when [Position Format] is selected to [Loran-C].	Set Loran C station and GRI combination.
[Short/Long Change Over]	Set the distance at which to change between short and long range.	[0.0] to [2.0] (NM)
[Range (Long)]	Set the unit of measurement for long distances.	[Nautical Mile], [Kilometer], [Mile]
[Range (Short)]	Set the unit of measurement for short distances.	[Foot], [Meter], [Yard]
[Depth]	Set the unit of measurement for depth.	[Foot], [Meter], [Fathom], [Passi Braza]
[Height/Length]	Set the unit of measurement for height and length.	[Foot], [Meter]
[Fish Size]	Set the unit of measurement for fish sizes.	[Inch], [Centimeter]
[Pound/Kilogram]	Set the unit of measurement for weight.	[Pound], [Kilogram]
[Temperature]	Set the unit of measurement for temperature.	[Fahrenheit Degree], [Celsius Degree]
[Boat Speed]	Set the unit of measurement for boat speed.	[Knot], [Kilometer per Hour], [Mile per Hour], [Meter per Second]
[Wind Speed]	Set the unit of measurement for wind speed.	[Knot], [Kilometer per Hour], [Mile per Hour], [Meter per Second]
[Atmospheric Pressure]	Set the unit of measurement for atmospheric pressure.	[HectoPascal], [Millibar], [Millimeter of Mercury], [Inch of Mercury]
[Oil Pressure]	Set the unit of measurement for oil pressure.	[KiloPascal], [Bar], [Pound per Square Inch]
[Volume]	Set the unit of measurement for tank volume.	[Gallon] (Gallon & Gallon/hour), [Litre] (Litre & Litre/hour)
[Reset Default Settings]	Restore default unit settings.	[OK], [Cancel]

### 3.3 Initial Setup

This section shows you how to set your system according to the sensors you have connected.

**Note 1:** Some units are set to metric in this section, actual setting ranges vary depending on the unit of measurement set in the [Units] menu.

**Note 2:** For configurations using the DFF-3D, refer to the instructions outlined in the operator's manual (OME-13520-xx; xx indicates publication version).

1. Tap the [Home] icon to show the home screen and display mode settings.
2. Tap [Settings] to show the [Settings] menu.
3. Drag the main menu, then tap [Initial Setup] to show the [Initial Setup] menu.
4. Referring to the tables on the following pages, set your equipment.

#### [GPS POSITION] menu

Menu item	Description	Options (setting range)
[Longitudinal (from bow)]	Referring to the figure on the right, enter the GPS antenna positioning bow-stern (Longitudinal) and port-starboard (Lateral) position from the origin.	0 (m) to 999 (m)
[Lateral (-Port)]		-99 (m) to +99 (m) Port-side is negative, Starboard-side is positive.



#### [BOAT INFORMATION] menu

Menu item	Description	Options (setting range)
[Boat Length]	Set the length of your boat.	0 (m) to 999 (m)
[Boat MMSI]	Set your boat's MMSI.	Max. 9 characters
[Boat Name]	Set your boat's name.	Max. 32 characters
[Size of Own Ship Icon]	Set the size of own ship icon.	50 to 150
[Depth Display]	Select the start point for depth measurement.	[Under Keel], [Under Sea Level]
[External Transducer Draft]	Set the draft external transducers other than internal fish finder, networked or multi-beam sonar. <b>For internal/network transducers</b> , set the draft from Home screen→[Settings]→[Sounder]→[Transducer Draft]. <b>For multi-beam sonars</b> , set the draft from Home screen→[Settings]→[Multi-beam Sonar]→[Initial Setup]→[External Transducer Draft].	0.0 (m) to 99.9 (m)
[Keel Draft]	Set the keel draft.	0.0 (m) to 99.9 (m)



**[INSTRUMENTS SETUP] menu - Engine & Tank, Graphic Instruments menus***Engine & Tank, Instruments Setup*

Menu item	Description	Options (setting range)
[Engine & Tank Automatic Setup]	See page 3-11.	
[Engine & Tank Manual Setup]	See page 3-11.	
[Graphic Instruments Setup]	See page 3-10.	

**[YAMAHA ENGINE SETUP] menu**

Menu item	Description	Options (setting range)
[Trip & Maintenance]	Reset fuel used, trip distance, engine trip and maintenance hours (trip hour, standard hour, optional hour, total hour).	[Trip Fuel & Distance]: [Fuel Used], [Trip Distance]. [Trip & Maintenance Hours]: [Port], [Starboard].
[Trim Level Calibration]	Trim all engines to fully down position (zero). If trim level is not zero, tap [SET] to set trim level to zero.	–
[Fuel Flow Calibration]	If the fuel flow indication (gph=gallons per hour) is wrong, you can calibrate the indication to show correct flow. Enter a negative value if the indication is higher than actual; a positive value if the indication is lower than actual.	-7 to +7
[Engine Interface Software Ver. & ID]	Display engine interface software version and ID.	–
[Reset Engine Interface]	Reset engine interface.	–
[Reset Engine Instance]	Reset engine instance.	–
[Reset Number of Engines]	Enter number of engines.	[1], [2], [3], [4], [4P], [4S]
[Trouble Codes]	Display trouble codes. See the operator's manual for the Yamaha engine for details.	–

**[IF-NMEAFI SETUP] menu**

Menu item	Description	Options (setting range)
[Select IF]	Select [IF-NMEAFI] to set the analog data that is input from the IF-NMEAFI. The setting is made after restarting the IF-NMEAFI.	
[Category]	Select the use (category) for this sensor.	[Wind], [ST800_850], [Fuel], [FreshWater], [WasteWater], [LiveWell], [Oil], [BlackWater]
[Resistance Full]	The resistance, in Ohms, when the tank is full.	0 (Ohm) to 500 (Ohm)
[Resistance Mid]	The resistance, in Ohms, when the tank is half full.	0 (Ohm) to 500 (Ohm)
[Resistance Empty]	The resistance, in Ohms, when the tank is empty.	0 (Ohm) to 500 (Ohm)
[Capacity]	The capacity of the tank.	0 (G) to 2650 (G)
[Fluid Instance]	Set the tank's NMEA2000 instance number.	0 to 5
[Self test]	Test results are displayed.	

### 3. EQUIPMENT SETUP

Menu item	Description	Options (setting range)
[Set Hardware to Factory Default]	Resets the converter selected at [Select IF] to factory default.	[OK], [Cancel]

#### **[DATA ACQUISITION] menu**

Menu Item	Description	Options (setting range)
[GP330B WAAS Mode]	Select [ON] to use the WAAS mode for the corresponding GPS antenna.	[OFF], [ON]
[WS200 WAAS Mode]		
[Data Source]	Select the source for each data to input to the system. If two or more sources are connected for a data, select one using the pull-down dialog box. The FURUNO products are shown at the upper part of the list.	
[Sensor List]	Show the information for sensors connected to your equipment. Also, you can set "Nickname" for them here.	
[NMEA0183 Output] <b>Note:</b> If the TTM sentence is received at the same time as another sentence, the constraints to communication bandwidth may cause a decrease in the number of TTM targets.	[Port Configuration] - [Baud Rate]: Select the output baud rate.	[4,800], [9,600], [38,400]
	[Port Configuration] - [NMEA-0183 Version]: Select the NMEA0183 version for output.	[1.5], [2.0], [3.0]
	[Sentences]: Select the sentences to output.	[OFF], [ON]
[NMEA2000 PGN Output]	Select [ON] for the PGN's (Parameter Group Number, CAN bus (NMEA2000) message) to output from the CAN bus port. <b>Note:</b> The default setting of some PGN's is "ON".	
[Sky View]	Show the condition of GPS and GEO (WAAS) satellites. Number, bearing and elevation angle of all GPS and GEO satellites (if applicable) in view of your GPS receiver appear.	

#### **[NMEA 2000 Log] menu**

Menu item	Description	Options (setting range)
[Enable NMEA 2000 Log]	Enable or disable saving of NMEA2000 data.	[OFF], [ON]
[NMEA2000 Log Storage Location]	Select where to save NMEA2000 data.	

#### **[SC-30 SETUP] menu**

This menu is only available with SC-30 connection.

Menu item	Description	Options (setting range)
[WAAS Mode]	Select [ON] to use the WAAS mode.	[OFF], [ON]
[Heading Offset]	Enter the offset value for heading.	-180° to +180°
[Pitch Offset]	Enter the offset value for pitching.	-90° to +90°
[Roll Offset]	Enter the offset value for rolling.	-90° to +90°

#### **[NETWORK SENSOR SETUP] menu**

The [NETWORK SENSOR SETUP] section allows you to set up compatible FURUNO NMEA2000 sensors. Calibrations and offsets applied in this menu are also applied to the sensor itself.

Tap the sensor to access its menus and settings. For details regarding the menu structure and set up of each sensor, see the appropriate operator's manual, supplied with the sensor.

**[CALIBRATION] menu**

Menu item	Description	Options (setting range)
[Heading]	Offset heading data.	-180.0° to +180.0°
[Speed Through Water]	Calibrate speed data. Enter amount in percentage.	-50% to +50%
[Wind Speed]	Offset wind speed data. Enter amount in percentage.	-50% to +50%
[Wind Angle]	Offset wind angle data.	-180° to +180°
[Sea Surface Temperature]	Offset sea surface temperature data.	-10°C to +10 °C

**[DATA DAMPING] menu**

Menu item	Description	Options (setting range)
[COG & SOG]	Set data damping time. The lower the setting the faster the response to change.	0 to 59 (seconds)
[Heading]		
[Speed Through Water]		
[Wind Speed & Angle]		
[Rate of Turn]		

**[FUSION] menu**

Menu item	Description	Options (setting range)
[Connect to Fusion]	Connects to your Fusion equipment.	
[Fusion Auto Volume]	Set to [ON] to allow the NavNet TZT2BB unit to control the FUSION volume. Volume is adjusted according to vessel speed.	[OFF], [ON]
[Minimum Speed]	Set the minimum speed threshold. Exceeding this speed activates volume auto control.	0.0 (kn) to 98.9 (kn)
[Maximum Speed]	Set the maximum speed threshold.	0.1 (kn) to 99.0 (kn)
[Volume Increase]	Set the amount of extra volume to output when the vessel reaches the [Maximum Speed] setting.	10% to 50%

**[BROWSER INSTALLATION] menu**

Menu item	Description	Option (setting range)
[FAX-30 Browser]	Show the Facsimile Receiver FAX-30 display.	
[FA-30 Browser]	Show the AIS Receiver FA-30 display.	
[FA-50 Browser]	Show the AIS Receiver FA-50 display.	

**[Initial Setup] menu (Other menu items)**

Menu item	Description	Option (setting range)
[Chart Master Device]	Set to [ON] to use this unit as the master, [OFF] to use this unit as a slave. (This menu does not appear on monitors connected to the HDMI OUT2 port.) <b>Note 1:</b> Set to [ON] on one of the TZT2BB on the network. For two or more TZT2BB, set to [ON] for only one unit. <b>Note 2:</b> For two or more TZT2BB, do not re-set this item once it has been set. If you set it incorrectly, get the unlock code. For information on how to get the unlock code, refer to Troubleshooting in the operator's manual.	
[System ID]	The system ID for this device within the network.	
[IP Address]	IP address for this unit within the network.	
[Synchronization Log]	Displays the network synchronization log.	
[Quick Self Test]	Displays various details regarding the TZT2BB unit, radar and fish finder.	

### 3. EQUIPMENT SETUP

Menu item	Description	Option (setting range)
[Certification Mark]	Displays relevant certification for this equipment.	
[Service]	Requires login password. For the service technician.	
[Event Input Configuration]	Set the function for the event switch.	[Off], [Event Mark], [MOB], [Ferry]
[Set Ext. Monitor IP Address]	Set IP address of connected monitor.	[Not Set], [172.31.26.190] - [172.31.26.199]
[Remote Controller Configuration]	When there are multiple units in the NavNet network, the MCU-004 (or MCU-005) can select the display to show on the unit connected with the Remote Controller. Further, the cycling order of displays can be set. See the Operator's Manual for details.	
[Adjust Display Resolution]	Adjusts the output resolution to match the resolution on the connected monitor.	
[Update Network Equipments]	For the service technician.	
[Sirius Radio Diagnostic]	Check the satellite radio of the FURUNO BBWX SiriusXM weather receiver for proper operation. See the Operator's Manual.	
[Sirius Weather Diagnostic]	Check the weather section of the FURUNO BBWX SiriusXM weather receiver for proper operation. See the Operator's Manual.	
[Reset Default Settings]	Reset the system to default settings.	[OK], [Cancel]

#### **[GRAPHIC INSTRUMENTS SETUP] menu**

##### *Maximum and Minimum boat speeds*

Menu Item	Description	Options (setting range)
[Maximum Boat Speed]	Set the transducer's maximum detectable speed.	1 (kn) to 99 (kn)
[Maximum Wind Speed]	Set the transducer's maximum detectable speed.	1 (kn) to 99 (kn)

##### *[DEPTH] menu*

Menu Item	Description	Options (setting range)
[Minimum Depth]	Set the transducer's minimum detectable depth.	0 (m) to 1999 (m)
[Maximum Depth]	Set the transducer's maximum detectable depth.	1 (m) to 2000 (m)

##### *[SEA SURFACE TEMPERATURE] menu*

Menu Item	Description	Options (setting range)
[Minimum Sea Surface Temperature]	Set the transducer's minimum detectable temperature.	0.00°C to 98.99°C
[Maximum Sea Surface Temperature]	Set the transducer's maximum detectable temperature.	0.01°C to 99.99°C

[PROPULSION ENGINE] or [OTHER ENGINE] menu

Menu Item	Description	Options (setting range)
[Max. RPM]	Set the maximum rpm of your engine to show on the RPM display.	1 (rpm) to 20,000 (rpm)
[Red Zone Oil Pressure]	Set the starting value for the red zone area of the oil pressure meter.	0 (psi) to 143 (psi)
Max. Oil Pressure	Set the maximum oil pressure of your engine.	1 (psi) to 144 (psi)
Min. Temperature	Set the minimum temperature for your engine.	0.00°C to 99.00°C
[Red Zone Temperature]	Set the starting value for the red zone area of the engine temperature indicator.	0.01°C to 999.00°C

CZone

Menu item	Description
[Add Default CZone Pages]	Create, edit C-Zone pages.
[CZone DIP Switch Settings]	Set this unit's DIP switches. For the serviceman. Do not change the settings.

Reset instrument pages, default settings

Menu item	Description
[Reset Instrument Pages]	Resets all instrument pages to default. [OK], [Cancel]
[Reset Default Settings]	Resets applicable settings to default. [OK], [Cancel]

**[Initial Setup] menu - [Engine & Tank Automatic Setup]**

The TZT2BB will automatically detect engines and tanks connected to the same network. This is the recommended method for setting up engines and tanks.

### 3. EQUIPMENT SETUP

#### **[Initial Setup] menu - [Engine & Tank Manual Setup]**

The manual set up method should only be used if the automatic setup did not correctly detect your engines or tanks.

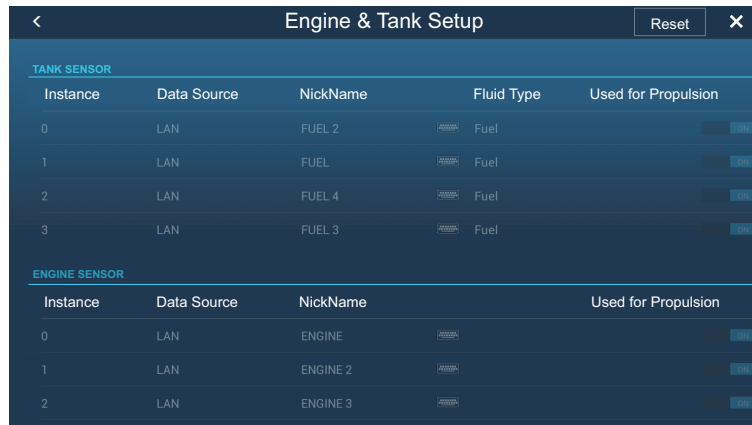

Menu Item	Description	Options (setting range)
[Instance]	Engine, tank NMEA2000 instance number.	
[Data Source]	Engine, tank source.	
[Nickname]	Change the nickname for the engine or tank.	
[Fluid Type]	Engine, tank, fluid type.	
[Used For Propulsion]	Select which engine/tank is used to calculate the distance which may be traveled using the remaining fuel. [ON] uses the engine/tank for calculations, [OFF] ignores the engine/tank.	[OFF], [ON]
[Reset]	Resets the engine/tank details to default.	

## 3.4 How to Set Up the Radar

1. Tap the [Home] icon to show the home screen and display mode settings.
2. Tap [Radar] from the [Settings] menu.
3. Tap [Radar Source], then select the appropriate radar sensor.

**Note:** If a DRS sensor is connected but does not appear in the [Radar Source] list, close the list and open it again. The name of the DRS sensor should appear with a check mark, as in the example below.

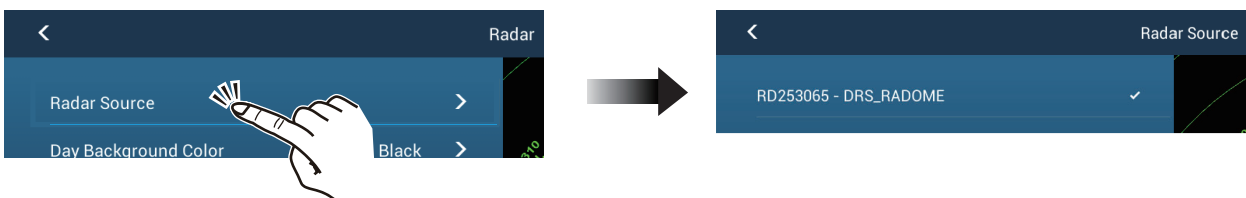

4. Drag the [Radar] menu display the menu item [Radar Initial Setup], then tap [Radar Initial Setup].
5. Referring to the tables on the following pages, set up the radar.

**[Radar] menu - [Radar Initial Setup]**

Menu item	Description	Options (setting range)
[Antenna Rotation]	Select the speed of antenna rotation. Not available (greyed out) with the radar sensor DRS4DL+.	[Auto], [24 RPM]
[Antenna Heading Align]	See "How to align the antenna heading" on page 3-14.	[-179.9°] to [+180.0°]
[Main Bang Suppression]	If main bang appears at the screen center, slide the circle icon so that the main bang disappears, while watching the radar echo at the left-hand side of the display.	[0] to [100]
[Enable Sector 1 Blanking]	Up to two sectors may be selected for blanking (no transmission). Select [ON] to enable this feature. Set the start and end angles (0° to 359°).	[ON], [OFF]
[Enable Sector 2 Blanking]		

**[Radar] menu - [Antenna Position]**

Menu item	Description	Options (setting range)
[Longitudinal (from bow)]	Referring to the figure on the right, enter the radar antenna positioning bow-stern (Longitudinal) and port-starboard (Lateral) position from the origin. 	[0] m to [999] m
[Lateral (-Port)]		[-99] m to [+99] m Port-side is negative, Starboard-side is positive.
[Antenna Height]	Select the height of the antenna above the waterline. Not available (grayed out) with the radar sensor DRS4DL, DRS4DL+.	[Under 3m], [3m-10m], [Over 10m]
[Auto Tuning]	Enable/disable auto tuning for the connected radar. Not available (grayed out) with the radar sensor DRS2D-NXT, DRS4D-NXT.	[ON], [OFF]
[Tuning Source]	Select a display in the dual range display to manually tune. Not available (grayed out) with the radar sensor DRS2D-NXT, DRS4D-NXT, DRS4DL, DRS4DL+.	[Range1], [Range2]
[Manual Tuning]	Manually tune the radar.	[-50] to [50]
[Radar Monitoring]	Display various information regarding the connected radar.	
[Radar Optimization]	Automatically adjust magnetron output and tuning for the connected radar. Available when the [TX/STBY] setting is [ON]. Do not change these settings. Not available (greyed out) with the radar sensor DRS2D-NXT, DRS4D-NXT, DRS6A-NXT, DRS12A-NXT, DRS25A-NXT. <b>Note 1:</b> For the service technician only. <b>Note 2:</b> Do this function whenever the magnetron is replaced.	
[ARPA Advanced Settings]	For service technician only. Do not change these settings. This item is available when [TX/STBY] is [ON]. Not available (grayed out) with the radar sensor DRS4DL, DRS4DL+, or FAR-2xx8, FAR-2xx7, FAR-15x8 series radar antenna.	
[TX Channel]	Select [1], [2] or [3], the channel where the interference is smallest. See the operator's manual for details. Available with the radar sensor DRS2D-NXT, DRS4D-NXT.	[Auto], [1], [2], [3]

### 3. EQUIPMENT SETUP

Menu item	Description	Options (setting range)
[Target Analyzer Mode]	You can emphasize rain clutter or target echoes when the target analyzer is active. Select [Rain] or [Target] as appropriate. See the operator's manual for details. Available with the radar sensor DRS2D-NXT, DRS4D-NXT, DRS6A-NXT, DRS12A-NXT, DRS25A-NXT.	[Rain], [Target]
[Auto acquire by Doppler]	When selecting [ON], approaching targets (ships, rain clutter, etc.) within 3 NM from own ship are automatically acquired by the Doppler calculated from the radar echo. See the operator's manual for details. Available with the radar sensor DRS2D-NXT, DRS4D-NXT, DRS6A-NXT, DRS12A-NXT, DRS25A-NXT.	[ON], [OFF]
[Set Hardware to Factory Default]	Resets the radar selected at [Radar Source] to factory default.	[OK], [Cancel]
[Reset Default Settings]	Resets [Radar] menu settings to default.	[OK], [Cancel]

#### **How to align the antenna heading**

You have mounted the antenna unit facing straight ahead in the direction of the bow. Therefore, a small but conspicuous target dead ahead visually should appear on the heading line (zero degrees).

In practice, you will probably observe some small bearing error on the display because of the difficulty in achieving accurate initial positioning of the antenna unit. The following adjustment will compensate for the error.

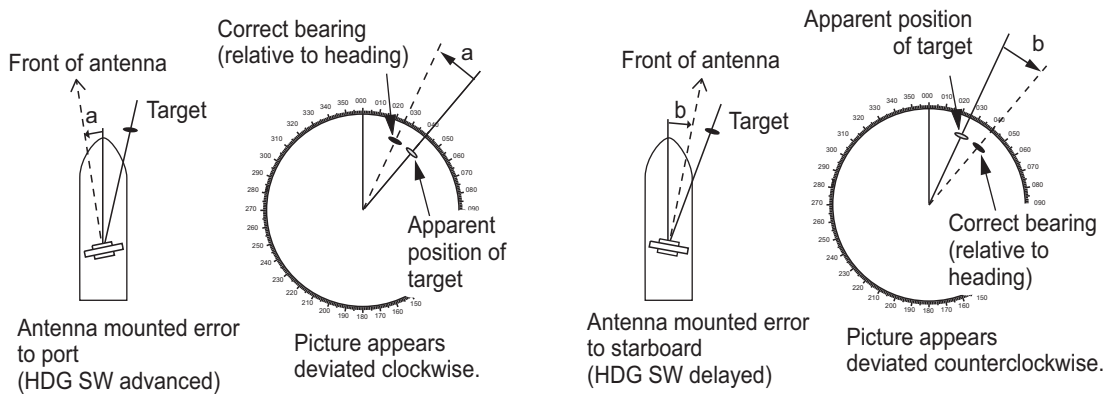

1. Set your radar with 0.125 and 0.25 nm range and the head up mode. You can select a range by using the pinch action. The range appears at the bottom right of the screen. Range may also be selected using the slide bar displayed on the right-hand side of the radar display area. Drag the bar up to zoom in, or down to zoom out.

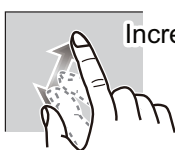

Increase range



Reduce range



*Radar indications*

2. Turn the vessel's bow toward a target.
3. Tap the [Home] icon to show the home screen and display mode settings.
4. Tap [Radar] to show the [Radar] menu.



5. Tap [Antenna Heading Align].
6. Key in an offset value (setting range: +179.9° to -180°) that puts the target at the very top of the screen, then tap the  icon.  
+: rotate echo in clockwise direction  
-: rotate echo in counterclockwise direction
7. Confirm that the target echo is displayed at correct bearing on the screen.

## 3.5 How to Set Up the Fish Finder

If you have a network sounder (BBDS1 or DFF series), set up the sounder as shown in this section.

**Note 1:** Some menu items are restricted to certain external depth sounders and that some menu items may not be available when using the internal depth sounder.

**Note 2:** For configurations using the DFF-3D, refer to the instructions outlined in the operator's manual (OME-13520-xx; xx indicates publication version).

1. Tap the [Home] icon to show the home screen and display mode settings.
2. Tap [Settings].
3. Drag the [Settings] menu to display [Fish Finder], then tap [Fish Finder].
4. Drag the [Fish Finder] menu to display the [FISH FINDER INITIAL SETUP] menu.

### Fish Finder Initial Setup menu

Menu item	Description	Options (setting range)
[Zero Line Rejection]	When you turn the zero line (transmission line) rejection on, the line is not shown, which allows you to see fish echoes near the surface. The width of the line changes with the transducer used and installation characteristics. If the width of the line is 1.4 m or more, select [ON]. <b>Note:</b> If DFF3, DFF3-UHD is connected and this item is set to [ON], set the range of rejection with [Zero Line Range].	[OFF], [ON]
[Zero Line Range]	You can set the zero line removal range by turning on [Zero Line Rejection]. If the tail of the zero line is long, set a large value. If the zero line still does not disappear, reduce the transmission power. The default setting is 2.0 <b>Note:</b> Shown with connection of DFF3, DFF3-UHD.	DFF3: 1.4 to 2.5 DFF3-UHD: 1.4 to 3.8
[Transducer Draft]	Set the distance between the transducer and the draft line to show the distance from the sea surface.	0.0m to 99.9m
[Salt Water]	Select [ON] if you use this equipment in salt water.	[OFF], [ON]
[Fish Finder Source]	Select the connected fish finder. To use the built-in fish finder, select [TZZ2BB], which is the default nickname. The nickname can be changed in [INITIAL SETUP]→[SENSOR LIST].	[TZZ2BB], [DFF1/BBDS1], [DFF3], [DFF1-UHD], [DFF3-UHD]
[Transducer Setup]	Setup Transducer and Motion Sensor. See "Transducer Setup menu" on page 3-17.	

### 3. EQUIPMENT SETUP

Menu item	Description	Options (setting range)
[Transmission Format]	Select whether to transmit high and low frequencies simultaneously or with a time delay. Normally, use [Parallel], which transmits the frequencies simultaneously. If you encounter interference near the bottom, select [Sequential] in order to suppress the interference. <b>Note:</b> Shown with connection of DFF3-UHD.	[Parallel], [Sequential]
[Transmission Power Mode]	Set the TX power level. See the operator's manual for details.	Internal fish finder: [Min], [Max] DFF1-UHD: [Off], [Min], [Auto] DFF3-UHD: 0 to 10
[External KP]	Select on to synchronize with external sounder's keying pulse. <b>Note:</b> Shown when the fish finder source is DFF1/BBDS1, DFF3, DFF1-UHD, DFF3-UHD,	[OFF], [ON]
[Bottom Level HF]	The default bottom level setting (0) determines that two strong echoes received in sequence are bottom echoes. If the depth indication is not stable in the default setting, adjust the bottom level here. If vertical lines appear from the bottom echo in the bottom lock display, lower the bottom level to erase the vertical lines. If you can not identify the fish near the bottom from the bottom echo, increase the bottom level.	-40 to +40
[Bottom Level LF]		-40 to +40
[Gain Offset HF]	If the gain setting is wrong, or there is a difference in the gain between the low and high frequencies, you can balance the gain for the two frequencies here.	-50 to +50
[Gain Offset LF]		-50 to +50
[Auto Gain Offset HF]	If the auto gain offset is wrong, or there is a difference in the gain between the low and high frequencies, set an offset here to balance auto gain for the two frequencies.	-5 to +5
[Auto Gain Offset LF]		-5 to +5
[STC HF]	Adjust the low (LF) or high (HF) STC frequency. See the operator's manual for details. <b>Note:</b> Shown with connection of DFF3, DFF1-UHD, DFF3-UHD.	0 to +10
[STC LF]		0 to +10
[TX Pulse HF]	The pulse length is automatically set according to range and shift, however it can also be set manually. Use a short pulse for better resolution and a long pulse when detection range is important. To improve resolution on zoom displays, use [Short 1] or [Short 2]. <ul style="list-style-type: none"> <li>[Short 1] improves the detection resolution, but the detection range is shorter than with [Std] (pulse length is 1/4 of [Std]).</li> <li>[Short 2] raises the detection resolution, however detection range is shorter (pulse length is about 1/2 of [Std]) than [Std].</li> <li>[Std] is the standard pulse length, and is suitable for general use.</li> <li>[Long] increases the detection range but lowers the resolution (about 1/2 compared to the [Std] pulse length)</li> </ul> <b>Note:</b> Shown with connection of DFF3, DFF3-UHD.	[Short1], [Short2], [Standard], [Long]
[TX Pulse LF]		[Short1], [Short2], [Standard], [Long]

Menu item	Description	Options (setting range)
[RX Band HF]	Set the bandwidth for low (LF) or high (HF) frequency. The RX bandwidth is automatically set according to pulse length. To decrease noise, select [Narrow]. For better resolution, select [Wide]. <b>Note:</b> Shown with connection of DFF3, DFF3-UHD.	[Narrow], [Standard], [Wide]
[RX Band LF]		[Narrow], [Standard], [Wide]
[Temperature Port]	Set the data source for water temperature. <ul style="list-style-type: none"> <li>[MJ Port]: Use the temperature/speed sensor for data.</li> <li>[Low Frequency]: Use the LF sensor for data.</li> <li>[High Frequency]: Use the HF sensor for data.</li> </ul> <b>Note:</b> Shown with connection of DFF3, DFF1-UHD.	[MJ Port], [Low Frequency], [High Frequency]
[Fish Finder Demo Mode]	The demo mode provides simulated operation using data stored in the internal memory. <ul style="list-style-type: none"> <li>[Off]: Disable the demo mode.</li> <li>[Demo 1-4]: Select a demo mode.</li> <li>[Shallow]: Enable shallow water demo mode.</li> <li>[Deep]: Enable deep water demo mode.</li> </ul> <b>Note:</b> Shown with connection of internal fish finder, BBDS1, DFF1, DFF3, DFF1-UHD.	Internal fish finder: [Off], [Demo1-4] BBDS1, DFF1, DFF3, DFF1-UHD: [Off], [Shallow], [Deep]
[Set Hardware to Factory Default]	Reset the external fish finder to its factory default settings.	[OK], [Cancel]
[Restore Default Settings]	Restore all menu settings to default.	[OK], [Cancel]

### Transducer Setup menu

For motion sensor related settings, see "Motion sensor menu" on page 3-19.

**Note:** Make sure that the unit is set to stand-by when setting up the transducer.

Menu item	Description	Options (setting range)
[Transducer Setup Type]	Select the type of transducer connected. When the connected sounder is a DFF1-UHD and the transducer has a compatible TDID, [TDID] is automatically selected. <b>Note:</b> When the transducer model is changed or TDID is detected, the frequency and bandwidth set on [Manual] is to be reset. <ul style="list-style-type: none"> <li>[Manual]: Manually set up the transducer.</li> <li>[Model]: Select the appropriate transducer model (for FURUNO or AIRMAR transducers).</li> </ul>	[Manual], [Model]
[Model Number]	Select the appropriate model number from the list. <b>Note:</b> Only available when [Transducer Setup Type] is set to [Model].	
[High Frequency Min]	Display the high frequency minimum.*	
[High Frequency Max]	Display the high frequency maximum.*	
[Low Frequency Min]	Display the low frequency minimum.*	
[Low Frequency Max]	Display the low frequency maximum.*	
[Restore Default Settings]	Restore all menu settings to default.	[OK], [Cancel]

### 3. EQUIPMENT SETUP

Menu item	Description	Options (setting range)
[Frequency Adjust HF]	Fine-tune the high-frequency TX frequency to eliminate interference (setting range: -50 to +50). Set to [0] where there is no interference. <b>Note:</b> These menu items appears when the DFF3, DFF3-UHD is connected.	-50 to +50
[Frequency Adjust LF]		-50 to +50

\*: Shown with connection of DFF3.

When [Transducer Setup Type] is set to [Model] and connected to DFF3, DFF3-UHD

Menu item	Description	Options (setting range)
[TX Mode HF]	Band adjustment mode for center frequency and CHIRP frequency of the transducer connected to the high frequency side.	[Auto CHIRP], [FM (Manual CHIRP)] <sup>*1</sup> , [CW (Fixed Frequency)] <sup>*2</sup>
[High Frequency]	Set the high frequency (kHz) of the transducer connected to the high frequency side.	
[Frequency Adjust HF]	If <sup>*1</sup> or <sup>*2</sup> is selected at [TX Mode HF], fine-tune the high-frequency TX frequency to eliminate interference (setting range: -50 to +50). Set to [0] where there is no interference.	
[CHIRP Width HF]	If <sup>*1</sup> is selected in [TX Mode HF], set the CHIRP frequency band of the transducer connected to the high frequency side.	
[TX Mode LF]	Band adjustment mode for center frequency and CHIRP frequency of the transducer connected to the low frequency side.	[Auto CHIRP], [FM (Manual CHIRP)] <sup>*1</sup> , [CW (Fixed Frequency)] <sup>*2</sup>
[Low Frequency]	Set the low frequency (kHz) of the transducer connected to the low frequency side.	
[Frequency Adjust LF]	If <sup>*1</sup> or <sup>*2</sup> is selected at [TX Mode LF], fine-tune the low-frequency TX frequency to eliminate interference (setting range: -50 to +50). Set to [0] where there is no interference.	
[CHIRP Width LF]	If <sup>*1</sup> is selected in [TX Mode LF], set the CHIRP frequency band of the transducer connected to the low frequency side.	

When [Transducer Setup Type] is set to [Manual]

Menu item	Description	Options (setting range)
[High Frequency]	Set the kHz frequency for high frequency. Setting ranges vary depending on the transducer connected. <b>Note:</b> Shown with connection of internal fish finder, DFF1, BBDS1, DFF3, DFF1-UHD.	
[Transducer Power HF]	Set the transmission power for high frequency. <b>Note 1:</b> Shown with connection of internal fish finder, DFF1, BBDS1. <b>Note 2:</b> For DFF1-UHD users, when the connected transducer TDID is not supported by the DFF1-UHD, the setting is fixed as [1000].	[600], [1000]
[Band Width (HF)]	Set the bandwidth for high frequency. <b>Note:</b> Shown with connection of DFF3.	

Menu item	Description	Options (setting range)
[Low Frequency]	Set the kHz frequency for low frequency. Setting ranges vary depending on the transducer connected. <b>Note:</b> Shown with connection of internal fish finder, DFF1, BBDS1, DFF3, DFF1-UHD.	
[Transducer Power LF]	Set the transmission power for low frequency. <b>Note 1:</b> Shown with connection of internal fish finder, DFF1, BBDS1. <b>Note 2:</b> For DFF1-UHD users, when the connected transducer TDID is not supported by the DFF1-UHD, the setting is fixed as [1000].	[600], [1000]
[Band Width (LF)]	Set the bandwidth for low frequency. <b>Note:</b> Shown with connection of DFF3.	

*When [Transducer Setup Type] is set to [Manual] and connected to DFF3-UHD*

Menu item	Description
[TX Volt HF]	Set the TX voltage (V) of the transducer connected to the high frequency side.
[TX Volt LF]	Set the TX voltage (V) of the transducer connected to the low frequency side.
[High Frequency]	Set the frequency (kHz) of the transducer connected to the high frequency side.
[Low Frequency]	Set the frequency (kHz) of the transducer connected to the low frequency side.

**Motion sensor menu**

The [Motion Sensor] menu sets up the motion sensor, which provides for stable display of the seabed, schools of fish, etc. in moderate-to-rough seas.

**Note 1:** TZT2BB does not support heaving correction. Motion sensor setup is not required if [Fish Finder Source] in the [Sounder] menu is set to [Internal].

**Note 2:** To use the heaving function, the following settings are required at the satellite compass. For the setting procedure, see the operator’s manual for your satellite compass. Settings for SC-30 are done from the [IF-NMEASC] menu, settings for SC-50/110 are done from the [DATA OUT] menu.

The [MOTION SENSOR] menu appears in the [Transducer Setup] menu when the [Heaving Correction] is activated in the [Fish Finder] menu. If the satellite compass SC-30 or SC50/110 is connected, set the distance between the antenna unit (or sensor) of the satellite compass and transducer (high and low if connected) here.

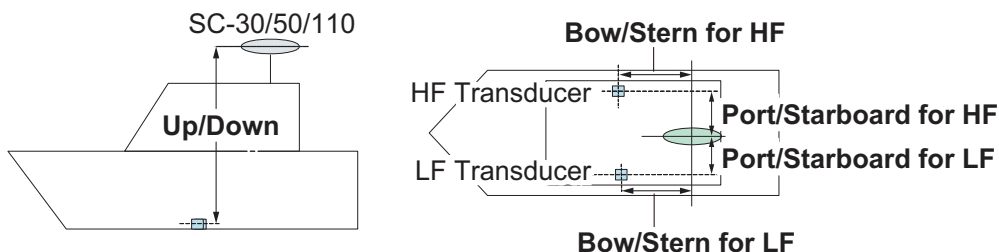

### 3. EQUIPMENT SETUP

Menu item	Description	Options (setting range)
[Motion Sensor Type]	Select the sensor connected to your TZT2BB unit. For all sensors other than SC-50/110, select [SC-30].	[SC30], [SC50_SC110]
[Antenna Position Bow/Stern HF (LF)]	Set the distance from the antenna unit to the transducer in the bow-stern direction. If the transducer is located on the fore side, set a positive value.	-99.9 to +99.9
[Antenna Position Up/Down HF (LF)]	Set the distance from the transducer to the antenna unit in the vertical direction.	-0.00 to +99.9
[Antenna Port/Starboard HF (LF)]	Set the distance from the antenna unit to the transducer in the port-starboard direction. If the transducer is located on the starboard side, set a positive value.	-99.9 to +99.9

## 3.6 Wireless LAN Settings

**Note:** The following procedures are not available from a monitor connected to the HDMI OUT2 port.

### 3.6.1 How to connect the existing LAN

1. Open the home screen, then tap [Settings]→[General]→[Connect to the Internet].

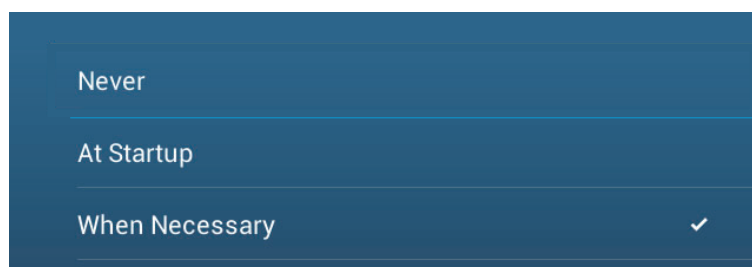

2. Tap [When Necessary]. Tap "<" to go back one layer.
3. Tap [Wireless LAN Settings]→[Wireless Mode].

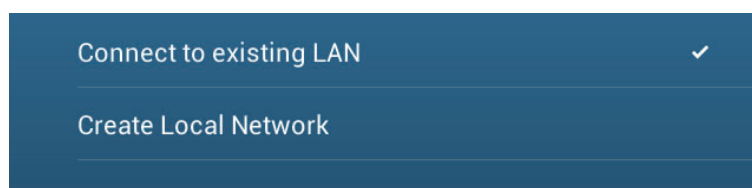

4. Tap [Connect to existing LAN]. Tap "<" to go back one layer.

- Turn on [Wireless] to see the available WLAN networks at the bottom of the screen.

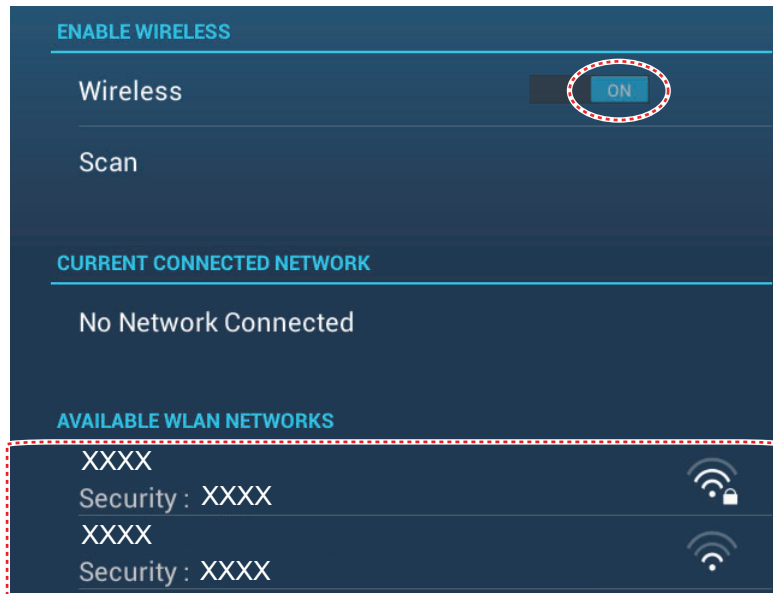

- Tap the network to use.

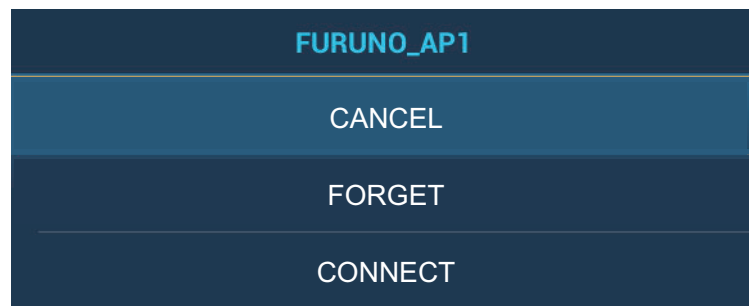

- Tap [Connect] to show the network key input window.

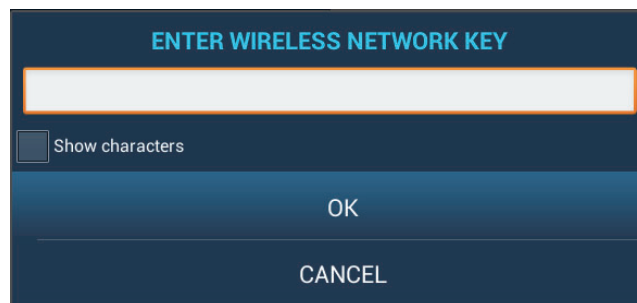

- Enter the network key, then tap [OK].
 

**Note:** If the network key is incorrect, an error message appears. Enter the correct key and tap [OK] again.
- Tap [X] on the title bar to close the menu.

### 3.6.2 How to create a local wireless network

**Note 1:** Do the procedure with [Local Network] in [Wireless LAN Settings] turned off.

**Note 2:** It may not be possible to connect to a local network if the network is unstable. In this case, turn [Wireless] off and on, or connect via an existing LAN network.

**Note 3:** Confirm that [When Necessary] is selected in [Connect to the Internet] before doing the procedure.

### 3. EQUIPMENT SETUP

1. Open the home screen, then tap [Settings]→[General]→[Wireless LAN Settings]→[Wireless Mode].
2. Tap [Create Local Network], then tap “<” to go back one layer.

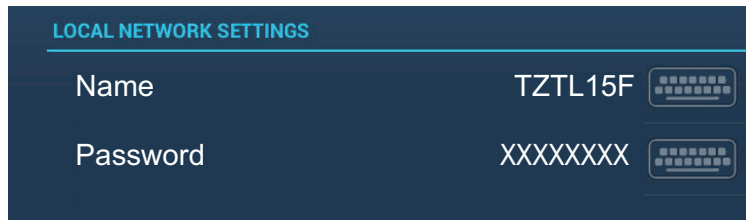

3. Tap [Name].
4. Enter the name of the network, then tap [✓].
5. Tap [Password].
6. Enter the password, then tap ✓.
7. Turn on [Local Network] in [Wireless LAN Settings] to connect to the network.
8. Tap [X] on the title bar to close the menu.
9. Connect to NavNet TZtouch2 at your tablet or smartphone.  
Use the network name and password, set up in this procedure, when connecting to the TZT2BB via tablet or smartphone.





# P A C K I N G L I S T

19BH-X-9853 -2 1/1

MPU-004/PSD-003-E/C

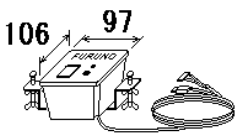
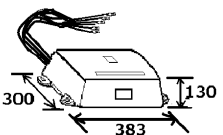
A-1

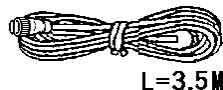
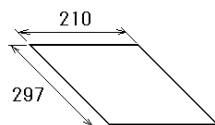
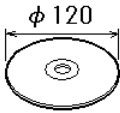
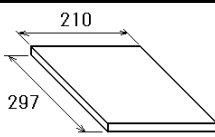
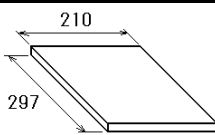
NAME	OUTLINE	DESCRIPTION/CODE No.	Q' TY
<b>ユニット UNIT</b>			
スイッチボックス SWITCH BOX		PSD-003-*	1
		000-034-830-00 **	
制御部 PROCESSOR UNIT		MPU-004-*	1
		000-034-825-00 **	
<b>予備品 SPARE PARTS</b>			
予備品 SPARE PARTS		SP19-00601	1
		001-023-040-00	
<b>工事材料 INSTALLATION MATERIALS</b>			
ケーブル(クミヒン)MJ CABLE ASSEMBLY		MJ-A3SPF0019-035C	1
		000-156-058-11	
工事材料 INSTALLATION MATERIALS		CP19-02101	1
		001-493-820-00	
<b>図書 DOCUMENT</b>			
フラッシュマウント型紙 FLASH MOUNTING TEMPLATE		C42-01207-*	1
		000-177-826-1*	
取扱説明CD OPERATOR'S MANUAL CD		TZTLXXF O/M *CD-ROM*	1
		000-190-093-1*	
操作要領書 OPERATOR'S GUIDE		OS*-44870-*	1
		000-190-070-1* **	
装備要領書(英) INSTALLATION MANUAL (EN)		IME-44960-*	1
		000-194-228-1*	

コード末尾に[\*\*]の付いたユニットは代表の型式/コードを表示しています。

CODE NUMBER ENDING WITH "\*\*" INDICATES THE CODE NUMBER OF REPRESENTATIVE MATERIAL.

(略図の寸法は、参考値です。 DIMENSIONS IN DRAWING FOR REFERENCE ONLY.)

C4496-Z03-C

CODE NO.	001-493-820-00	198H-X-9401-0
TYPE	CP19-02101	1/1

工事材料表 INSTALLATION MATERIALS		略図 OUTLINE		型名/規格 DESCRIPTIONS		数量 QTY		用途/備考 REMARKS	
番号 NO.	名称 NAME			GRFC-9		1			
1	EMI CORE								
2	コネクタ帽 CONNECTOR CAP			CAP-15-035A		1			
3	コネクタ帽 CONNECTOR CAP			CAP-15-035B		1			
4	+selfタッピングボルト SELF-TAPPING SCREW			5X20 SUS304		4			

(略図の寸法は、参考値です。 DIMENSIONS IN DRAWING FOR REFERENCE ONLY.)

FURUNO ELECTRIC CO . . LTD.

CODE NO.	001-493-860-00	198H-X-9501-0
TYPE	FP19-02101	1/1

付属品表 ACCESSORIES		略図 OUTLINE		型名/規格 DESCRIPTIONS		数量 QTY		用途/備考 REMARKS	
番号 NO.	名称 NAME			1950188-		1			
1	SDカード書込み品 SD MEMORY CARD								
2	WiFi_LARIBステッカー WiFi_LARIB STICKER			19-031-1563-0		1			

(略図の寸法は、参考値です。 DIMENSIONS IN DRAWING FOR REFERENCE ONLY.)

FURUNO ELECTRIC CO . . LTD.

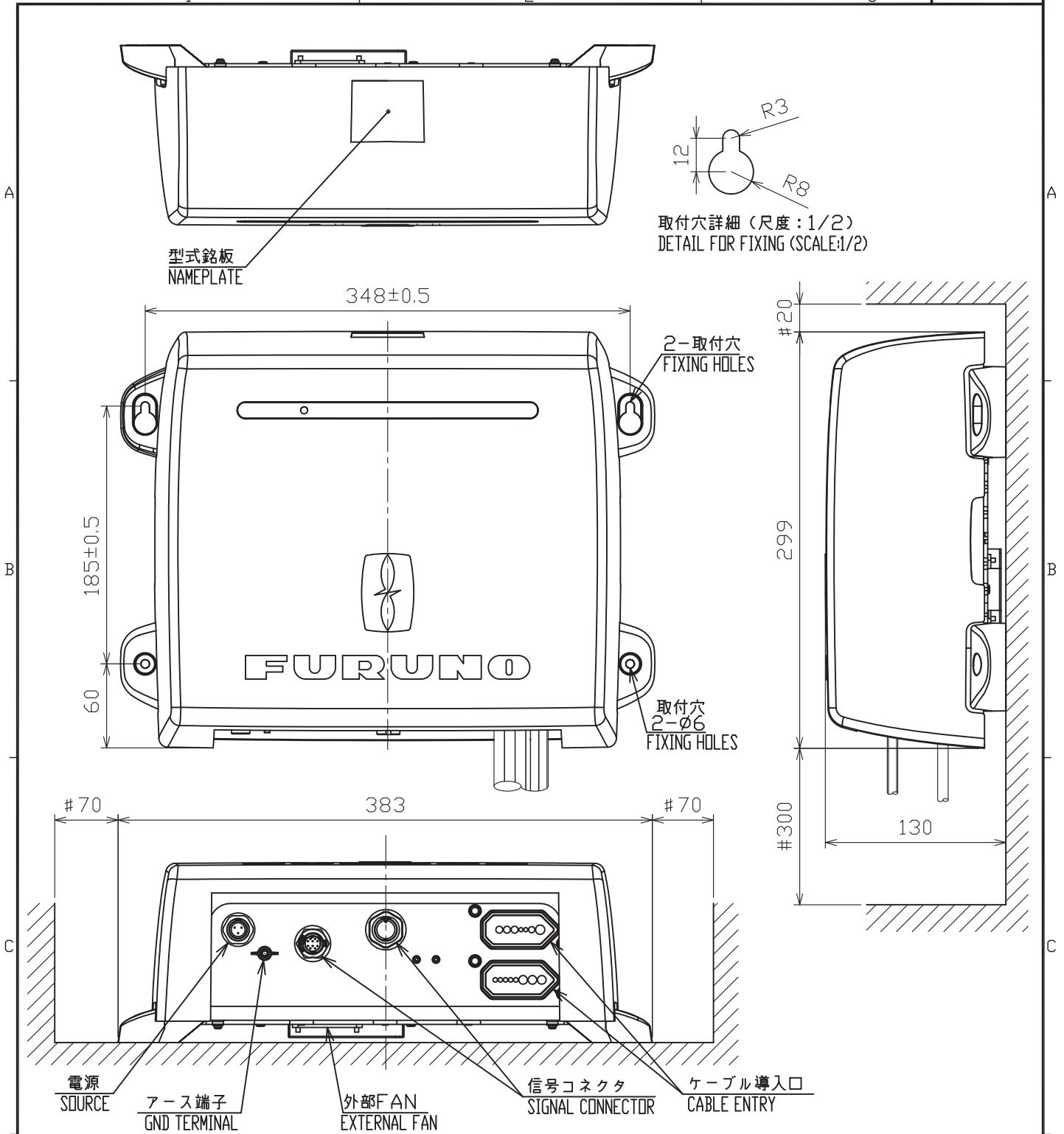

注記

- 1) 指定なき寸法公差は表1による。
- 2) #印寸法は最小サービス空間寸法とする。
- 3) 取付用ネジはトラスタップネジ呼び径5×20を使用のこと。

NOTE

1. TABLE 1 INDICATES TOLERANCE OF DIMENSIONS WHICH IS NOT SPECIFIED.
2. #: MINIMUM SERVICE CLEARANCE.
3. USE TAPPING SCREWS φ5x20 FOR FIXING THE UNIT.

表1 TABLE 1

寸法区分(mm) DIMENSION	公差(mm) TOLERANCE
0 < L ≤ 50	±1.5
50 < L ≤ 100	±2.5
100 < L ≤ 500	±3

DRAWN 20/Jul/2017 A. MURAD	TITLE MPU-004
CHECKED 20/Jul/2017 T. YAMASAKI	名称 制御部(卓上・壁掛装備)
APPROVED 1/Aug/2017 H. MAKI	外寸図
SCALE 1/4	NAME PROCESSOR UNIT (TABLETOP/BULKHEAD MOUNT)
MASS 3.9 ±10% kg	質量はケーブルを含む。 MASS INCLUDES CABLE.
DWG.No. C4496-G01-A	REF.No. 19-032-300G-4
	OUTLINE DRAWING



表 1 TABLE 1

寸法区分(mm) DIMENSION	公差(mm) TOLERANCE
0 < L ≤ 50	±1.5
50 < L ≤ 100	±2.5
100 < L ≤ 500	±3



取付穴寸法  
CUTOUT DIMENSIONS

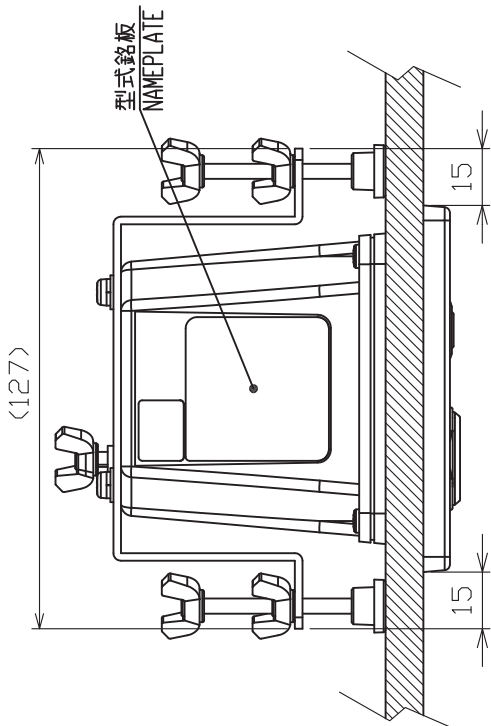
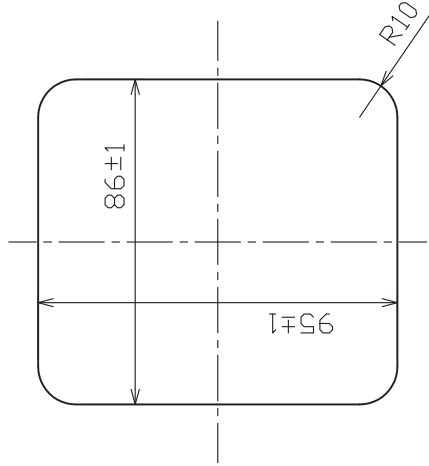
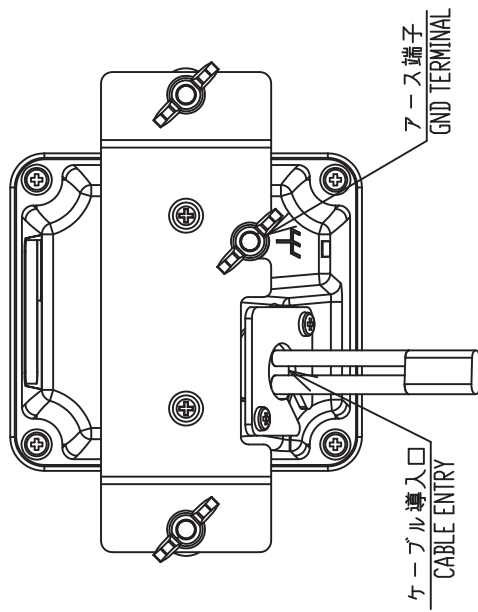
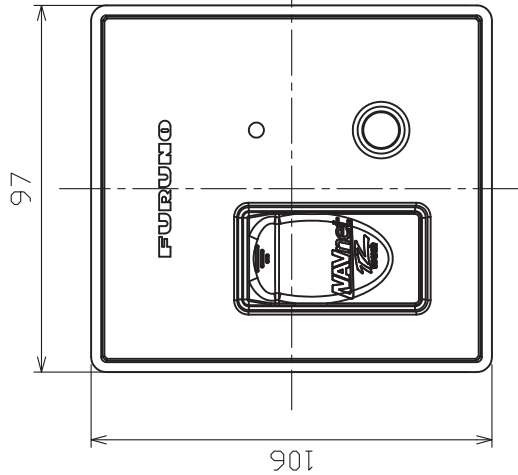
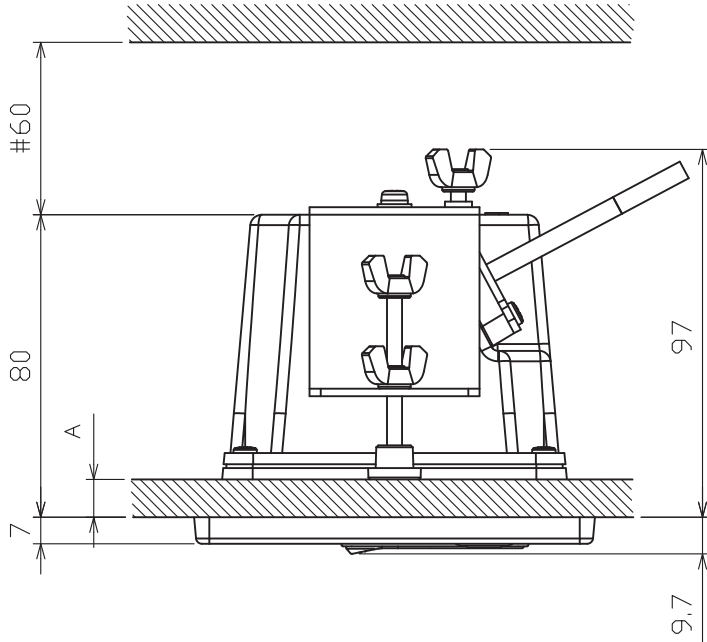

- 注記
- 1) 指定なき寸法公差は表 1 による。
  - 2) # 印寸法は最小サービス空間寸法とする。
  - 3) 壁の厚さ (A) は  $5 \leq A \leq 20$  とする。

- NOTE
1. TABLE 1 INDICATES TOLERANCE OF DIMENSIONS WHICH IS NOT SPECIFIED.
  2. # MINIMUM SERVICE CLEARANCE.
  3. BULKHEAD THICKNESS (A):  $5 \leq A \leq 20$

DRAWN	20/Jul/2017	A. MURAD	TITLE	PSD-003
CHECKED	20/Jul/2017	T. YAMASAKI	名称	スイッチボックス(埋込装備)
APPROVED	1/Aug/2017	H. MAKI	外寸図	
SCALE	1/2	100% 質量はケーブルを含まず。 MASS DOES NOT INCLUDE CABLE.	NAME	SWITCH BOX (FLUSH MOUNT)
DWG.No.	C4496-G02-A	19-032-310G-0	OUTLINE DRAWING	

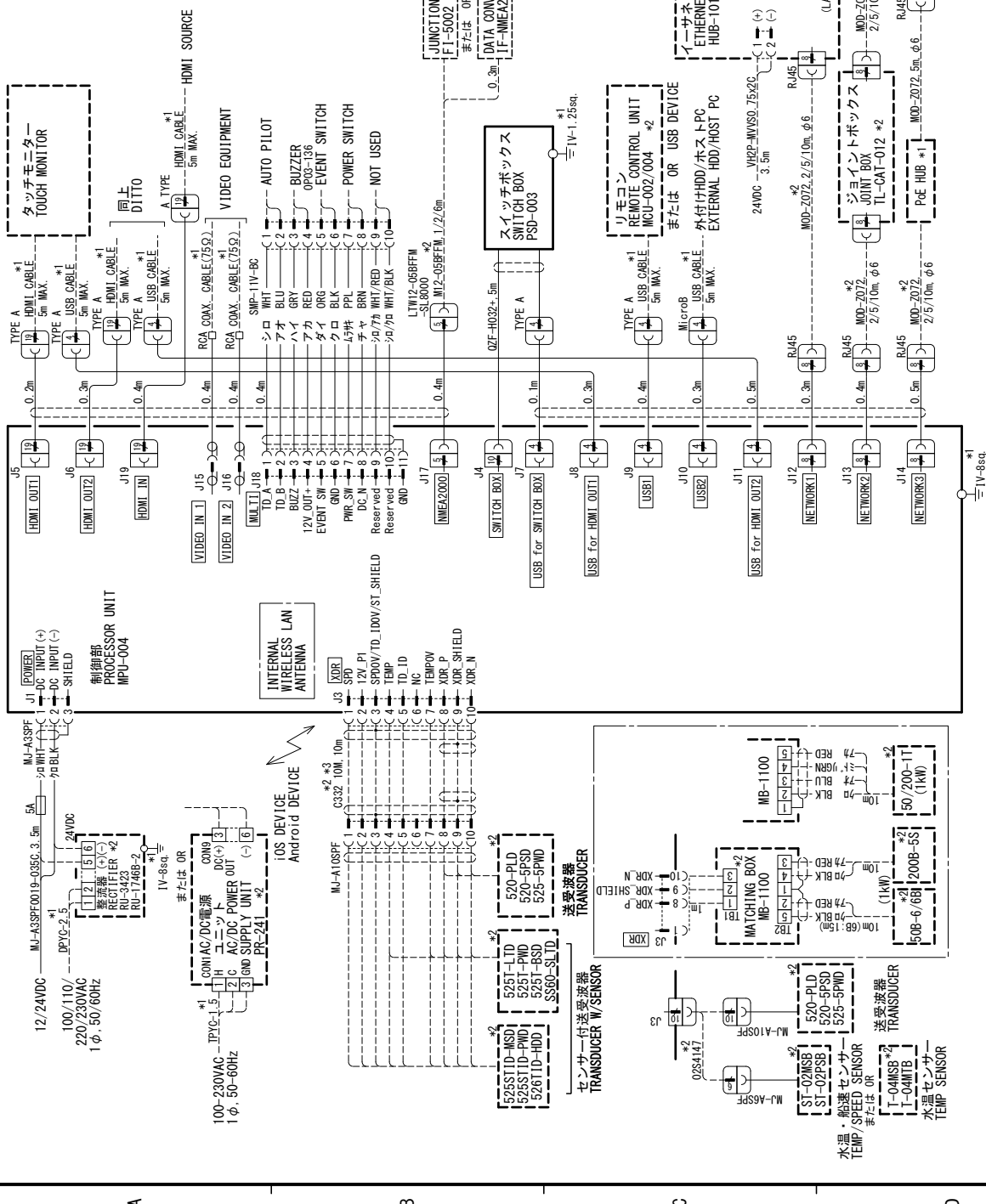

DRAWN	21/Jun/2021 U. PODDAR	TITLE	TZT2BB
CHECKED	21/Jun/2021 T. YAMASAKI	名称	マルチファンクションディスプレイ
APPROVED	22/Jun/2021 H. MAKI	互換接続図	相互接続図
SCALE	1/MS	NAME	MULTI FUNCTION DISPLAY
DWG No.	04496-C01-C	REF. No.	19-032-7001-90
			INTERCONNECTION DIAGRAM

注記  
 \*1) 造船所手配。  
 \*2) オプション。  
 \*3) ケーブル延長の場合、ACCU-FISH性能低下の恐れあり。

NOTE  
 \*1: SHIPYARD SUPPLY.  
 \*2: OPTION.  
 \*3: ACCU-FISH PERFORMANCE MAY BE DECLINED BY CABLE EXTENSION.

その他、別々の資料を確認のこと  
 FACS IMILE RESCUEIVER、IP CAMERA、ETC.  
 FAX-30、OTHERS  
 (REFER TO INDIVIDUAL INSTRUCTIONS FOR CONNECTION)

ネットワーク機器  
 DFF1/3、BBD51、DFF1-UHD、DFF3D  
 AIS受信機  
 FA-30/50  
 レーダーセンサー  
 DRS SERIES

インターネットハブ  
 ETHERNET HUB  
 HUB-101 \*2  
 データコンバーター  
 JF-IMEA2K2 \*2  
 ジョイントボックス  
 TL-CAT-012 \*2  
 リモコン  
 REMOTE CONTROL UNIT  
 MCU-002/004 \*2  
 外部付HDD/ホストPC  
 EXTERNAL HDD/HOST PC

タッチモニター  
 TOUCH MONITOR  
 同上  
 DITTO  
 HDMI SOURCE  
 VIDEO EQUIPMENT  
 SMP-TLV-BC  
 ショット  
 ID.B  
 BUZZER  
 12V、OUT+  
 EVENT SW  
 PMW SW  
 DC、N  
 Reserved  
 GND

センサー付送波器  
 TRANSDUCER W/SENSOR  
 525T-LID  
 525T-PND  
 525T-BSD  
 525T-SPND  
 526T-ID-HDD  
 525T-PLD  
 520-SPSD  
 525-SPSD  
 525-SPMD

送波器  
 TRANSDUCER  
 MB-1100  
 50B-6/6B  
 50B-200-11  
 50B-200-5S

水溫・船速センサー  
 TEMP./SPEED SENSOR  
 ST-02MSB  
 ST-02PSB  
 T-04MSB  
 T-04MTB

送波器  
 TRANSDUCER  
 525T-LID  
 525T-PND  
 525T-BSD  
 525T-SPND  
 526T-ID-HDD  
 525T-PLD  
 520-SPSD  
 525-SPSD  
 525-SPMD

送波器  
 TRANSDUCER  
 MB-1100  
 50B-6/6B  
 50B-200-11  
 50B-200-5S

A

B

C

D