

# B164 SS164

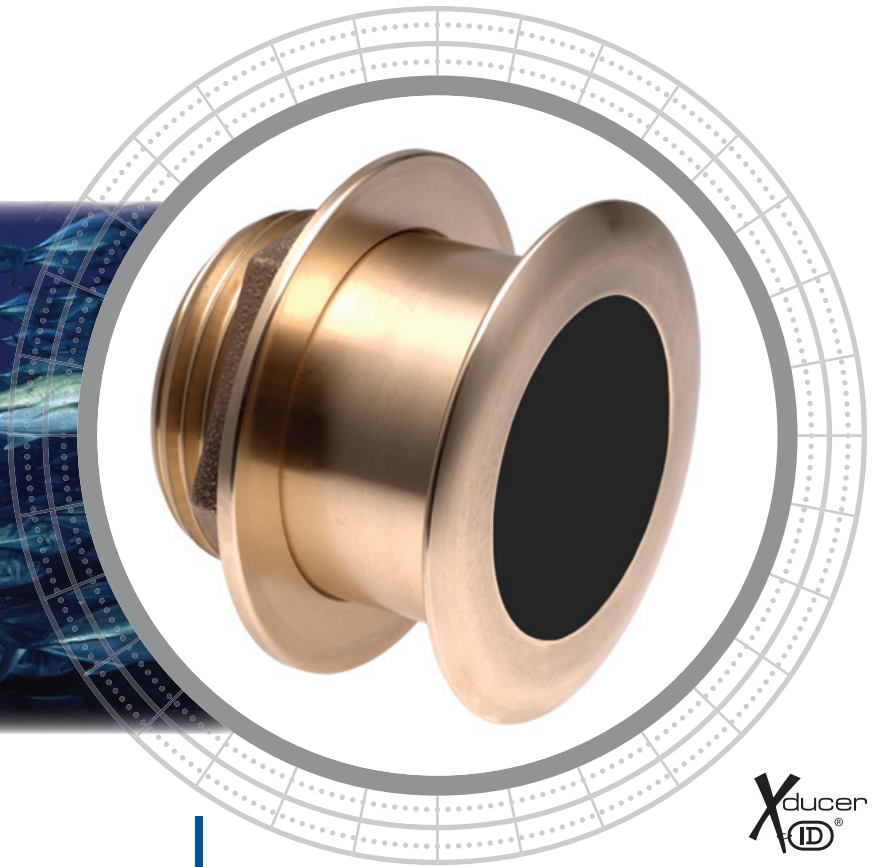

## Aim in the Right Direction

Airmar has taken our innovative Tilted Element™ technology to a higher power. The 1kW, B164 transducer is perfect for fast, trailered, tournament, sportfishing vessels that cannot install a thru-hull with a High-Performance Fairing. The low-profile bronze housing protrudes less than 6.35 mm (0.25") outside your hull, which results in excellent performance at speeds up to 30 knots (34 MPH).

## Fine Tune Your Fishing

The ceramic arrays are tilted inside the housing giving you a perfect vertical beam with maximum energy on what is directly below your boat. Take your fishfinder to the next power with Airmar's 1kW Tilted Element Transducers.



Stainless steel housing—SS164

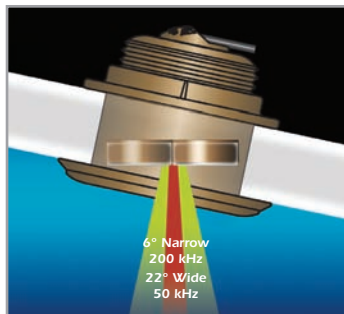

The ceramic elements are tilted inside the housing, which compensates for your boat's deadrise. This aims the beam straight toward the bottom, resulting in stronger echo returns and more accurate depth readings.

## Tilted Element™ Thru-Hull 1 kW

### Fishing Applications

- Inshore and blue-water trolling
- Deep-water bottom and structure fishing up to 500 m (1,640')
- The versatile 1 kW transducer for all types of fishing

### Features

- Fixed 20° tilted version for 16° to 24° hull deadrise
- Fixed 12° tilted version for 8° to 15° hull deadrise
- Fixed 0° tilted version for 0° to 7° hull deadrise
- 1 kW power, 50/200 kHz multiple-ceramics
- Engineered for center-console and trailered boats
- Low-profile protrusion below the hull
- No affect on your boats running performance
- Interfaces to any 600 W or 1 kW echosounder
- Bronze or stainless steel housings available
- Depth and fast-response water-temperature sensor
- Boat Size: 8 m to 11 m (25' to 35')



*Sensing Technology*

# B164, SS164

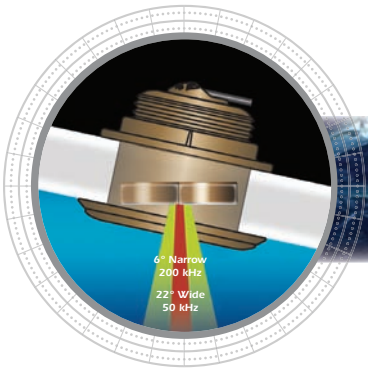

## Technical Information

### 50/200 kHz-Glq

Number of Elements and Configuration		
Beamwidth (@-3 dB)	22° x 20°	6° x 6°
RMS Power (W)	1 kW	1 kW
TVR	158 dB	168 dB
RVR	-177 dB	-189 dB
FOM	-23 dB	-19 dB
Q	7	17
Impedance	240 Ω	180 Ω

### MAXIMUM DEPTH RANGE

50 kHz	200 kHz
353 m to 529 m (1,200' to 1,800')	152 m to 235 m (500' to 800')

### BEAM DIAMETER VS DEPTH

Depth	50 kHz	200 kHz
9 m (30')	4 m x 3 m (12' x 10')	0.9 m x 0.9 m (3' x 3')
31 m (100')	11 m x 10.6 m (38' x 35')	3.3 m x 3.3 m (11' x 11')
122 m (400')	47 m x 43 m (156' x 141')	13 m x 13 m (42' x 42')
305 m (1,000')	118 m x 107 m (389' x 353')	32 m x 32 m (105' x 105')

### TRANSDUCER COMPARISON

Model	Power	Rating	Performance Increase
B60 SS60	600 W	Good	Benchmark model for comparison
<b>B164 SS164</b>	<b>1 kW</b>	<b>Better</b>	<b>6 times more sensitive at 50 kHz</b> <b>2 times more sensitive at 200 kHz</b>
SS264N	1 kW	Best	50 times more sensitive at 50 kHz 13 times more sensitive at 200 kHz

Due to the wide beam of the SS264W, it has been omitted from the table.

### SPECIFICATIONS

**Weight:** 2.7 kg (6 lb)  
**Hull Deadrise:** Up to 28°  
**Acoustic Window:** Urethane

### DIMENSIONS

